



# SPECIFICATION

## Surface Acoustic Wave Filter

**USER**

**USER PART No.**

**WISOL PART No.**            **SFH881YA002**

**DOC. No.**                    **SMS-51-L-SFT FX-27**

**DATE**                        **May 22, 2013**

**REVISION**                 **000**

<b>WISOL</b>					
ISSUED BY	Kim, Kyung-Sik  	APPROVED BY (R&D)	Hong, Seong-Su  	APPROVED BY (QC)	Jeon. Hyeon Cheol  
<b>User</b>					
ISSUED BY		CHECKED BY		APPROVED BY	

**WISOL CO., LTD.**  
 373-7, GAJANG-DONG, OSAN-SI,  
 GYUNGGI-DO, KOREA, 447-210  
<http://www.wisol.co.kr>

**▶ A TABLE OF CONTENTS**

<b>1. REVISION HISTORY</b> .....	3
<b>2. DEFINITION</b> .....	4
<b>3. PRECAUTIONS</b> .....	4
<b>4. OUTLINE DRAWING &amp; DIMENSIONS</b> .....	5
<b>6. PERFORMANCE</b> .....	7
6-1. MAXIMUM RATINGS .....	7
6-2. ELECTRICAL CHARACTERISTICS .....	8
6-2-1. TABLE.....	8
6-2-2. TEST FIXTURE .....	8
6-2-3. GRAPH .....	9
<b>7. RELIABILITY</b> .....	10
7-1. ENGINEERING SAMPLE FLOW CHART .....	10
7-2. TEST ITEM & CONDITION .....	11
<b>8. REFLOW CONDITION</b> .....	12
<b>9. RECOMMENDED PCB DIMENSIONS</b> .....	12
<b>10. CAUTION</b> .....	13
<b>11. PACKING</b> .....	14
11-1. DIMENSIONS.....	14
11-2. REELING QUANTITY .....	15
11-3. TAPING STRUCTURE.....	15
11-4. INNER BOX(Reel Packing) STRUCTURE.....	16
11-5. OUTER BOX STRUCTURE.....	17
<b>12. TAPE SPECIFICATIONS</b> .....	18
<b>13. RoHS DATA</b> .....	19

## 1. REVISION HISTORY

000 May 22, 2013 All Page Make specification

## 2. DEFINITION

2-1. PART No.

S F H 881 Y A0 02

(1) (2) (3) (4) (5) (6)

No.	EXPLANATION	
(1)	SAW Filter	
(2)	Design Type	
(3)	Center Frequency:	881.5MHz(869 ~ 894)
(4)	Input:50ohm,Output:100ohm	
(5)	Package size: 1.1×0.9mm <sup>2</sup>	
(6)	Design Revision (02 : Molding Type)	

2-2. APPLICATION : Band-Pass Filter for CDMA Rx etc (UMTS Band V)

## 3. PRECAUTIONS

3-1. This device should not be used in any type of fluid such as water, oil, organic solvent, etc.

3-2. This is a hermetic device.

MSL(Moisture Sensitive Level) is the '2a' level.

3-3. Ultrasonic cleaning shall be avoided.

3-4. Isopropyl Alcohol and Ethyl Alcohol can be used for cleaning. Contact us before using other cleaning solvents than above

3-5. This is an electrostatic sensitive device.

Please avoid static voltage during operation and storage.

3-6. Sudden change of temperature shall be avoided, deterioration of the characteristics can occur.

3-7. If any malfunction due to designing or manufacturing which is out of specification occurs within one year after the products have been delivered, the maker should exchange the defective products.

4. OUTLINE DRAWING & DIMENSIONS

< UNIT : mm >

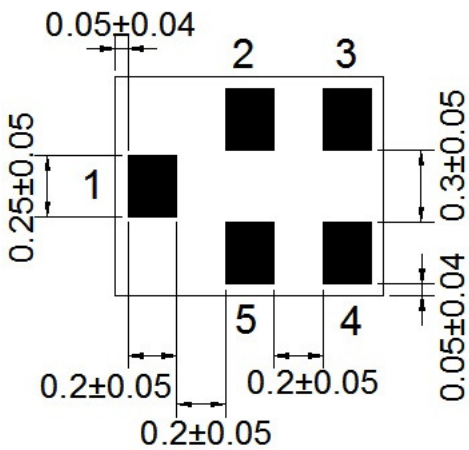
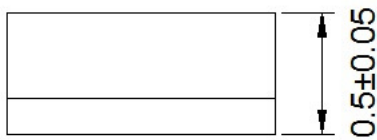
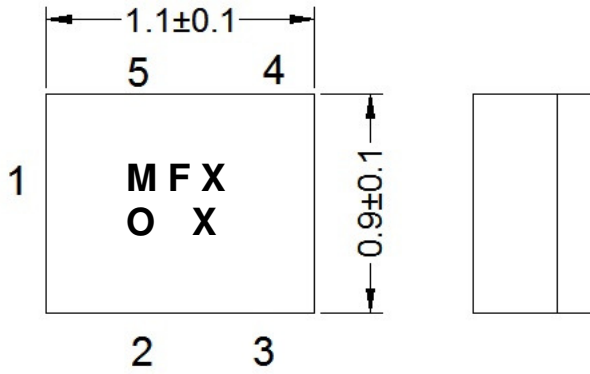

No.	Function
2, 5	Ground
1	Unbalanced Input
3,4	Balanced Output

## 5. MARKING



### 5-1. M F X X

- The 1st, 2nd character 'MF' indicates the model name of SAW Filter “SFH881YA002” .
- The 3rd character 'X' indicates the year and the month of manufacture.

Year	Month											
	1	2	3	4	5	6	7	8	9	10	11	12
2013	P	Q	R	S	T	U	V	W	X	Y	Z	a
2014	1	2	3	4	5	6	7	8	9	A	B	C
2015	D	E	F	G	H	I	J	K	L	M	N	O
2016	P	Q	R	S	T	U	V	W	X	Y	Z	a

※ This rotates by the 3 years.

- The 4th character 'X' indicates day of manufacture.

### 5-2. ○

- This symbol indicates input pin 1.
- This indicates the producing center  
○: China,

### 5-3. Marking: Laser Marking

## 6. PERFORMANCE

### 6-1. MAXIMUM RATINGS

CHARACTERISTICS	RATINGS	UNITS
DC Permissive Voltage	5	V
Maximum Input Power	15	dBm
Operating Temperature Range	- 30 ~ +85	°C
Storage Temperature Range	- 40 ~ +85	°C

**6-2. ELECTRICAL CHARACTERISTICS**
**6-2-1. TABLE**

Ta = -30 ~ +85°C

Item	FREQUENCY RANGE [MHz]	UNIT	SPECIFICATION		
			Min.	Typ. (25°C)	Max.
Insertion Loss	869 ~ 894	dB	-	1.9	2.5
Inband Ripple	869 ~ 894	dB	-	0.5	1.2
Input VSWR	869 ~ 894	-	-	1.5	2.0
Output VSWR	869 ~ 894	-	-	1.6	2.0
Amplitude Imbalance	869 ~ 894	dB	-1.0	-	-1.0
Phase Imbalance	869 ~ 894	degree	-10	-	+10
Absolute Attenuation	DC ~ 824	dB	50	58	-
	824 ~ 849	dB	48	53	-
	1738 ~ 1788	dB	50	59	-
	1850 ~ 1910	dB	50	59	-
	1920 ~ 1980	dB	50	60	-
	2400 ~ 2484	dB	48	57	-
	3296 ~ 3396	dB	40	51	-
	3396 ~ 6000	dB	27	36	-
Termination Impedance		Input: Unbalanced 50 ohm Output: Balanced 100 ohm // 82nH			

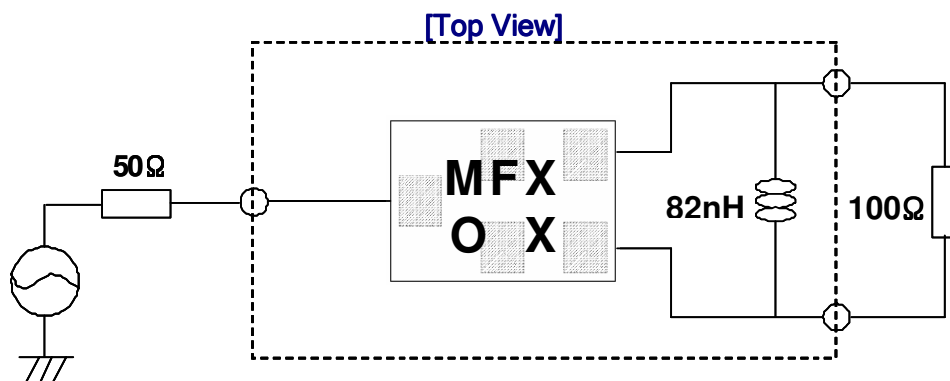
**6-2-2. TEST FIXTURE**



6-2-3. GRAPH

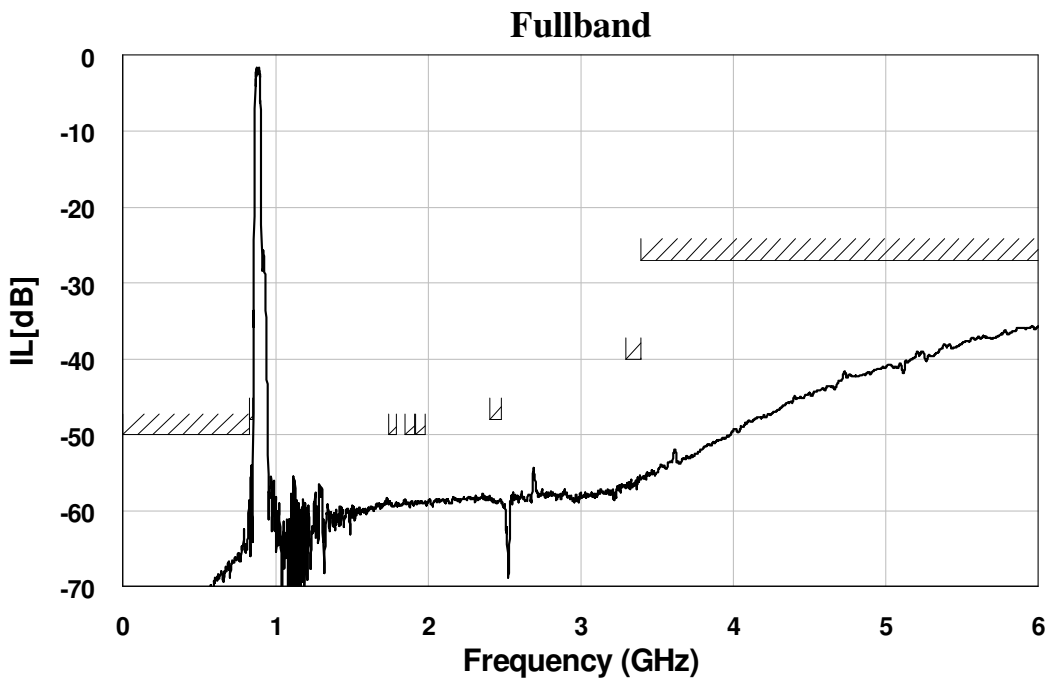
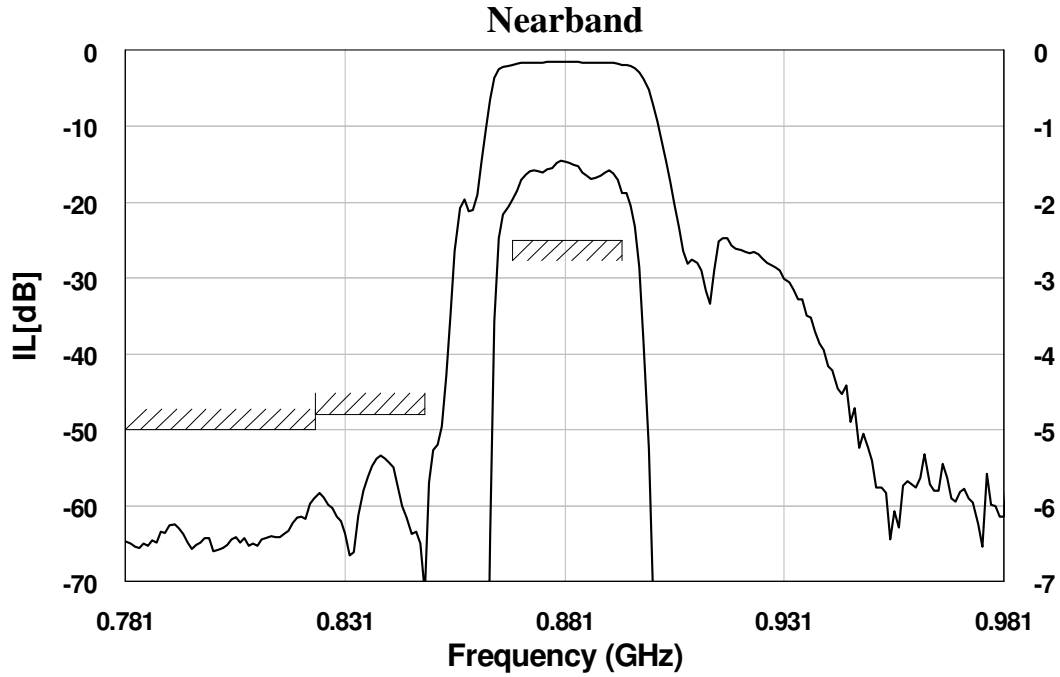

## 7. RELIABILITY

### 7-1. ENGINEERING SAMPLE FLOW CHART

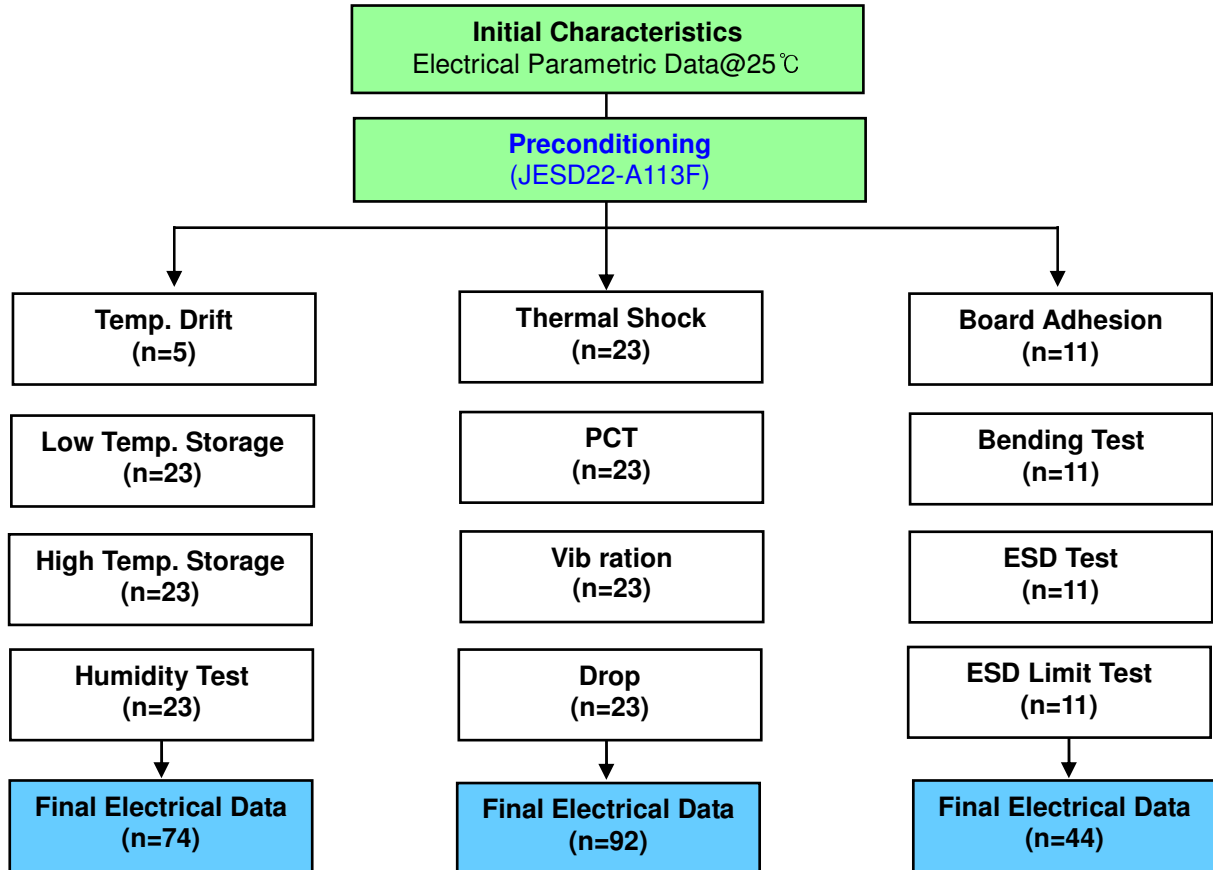

**7-2. TEST ITEM & CONDITION**

CATEGORY	TEST ITEM	TEST CONDITION	REMARK
	Preconditioning	+125℃ 24hr Baking → +60℃ 60%RH 120hr → Reflow Test(3times)	JESD22A113F



Environment Test	Temp. Drift	-30℃ → +25℃ → +85℃	description
	High Temp. Storage	+85℃ 240hr	JESD22-A103C
	Low Temp. Storage	-40℃ 240hr	JESD22-A119
	High Temp. High Humidity Storage	+85℃ 85%RH 240hr	JESD22-A106B
	Thermal Shock	-40℃/30min ⇔ +85℃/30min , 100cycle	JESD22-A106A
	High Temp. Operating	+121℃ 100%RH 96hr	JESD22-A102C
Mechanical Test	Vibration Test (Random)	20 Hz~2000 Hz,0.053G <sup>2</sup> /Hz or 8g's RMS,15min/plane	IEC 68-2-36 Fdb
	Drop Test	152 cm 12times Steel floor JIG(110g~150g)	IEC 1178-1.4.8.9
	Board Adhesion	0.5 mm/sec 1point push	IEC 68-2-21 Ue3
	Bending Test	0.5 mm/sec 3times -PCB : FR4 , PCB SIZE : 100*40 mm	IEC 68-2-21 Ue3
Physical Test	Solder Heat Resistance	±250V,C=100pF,R=1.5 kΩ, 1times	IEC 68-2-21 Ue3
	static marginal test	C=100pF,R=1.5 kΩ, 1times(demand of customer)	JESD22-A114F

8. REFLOW CONDITION

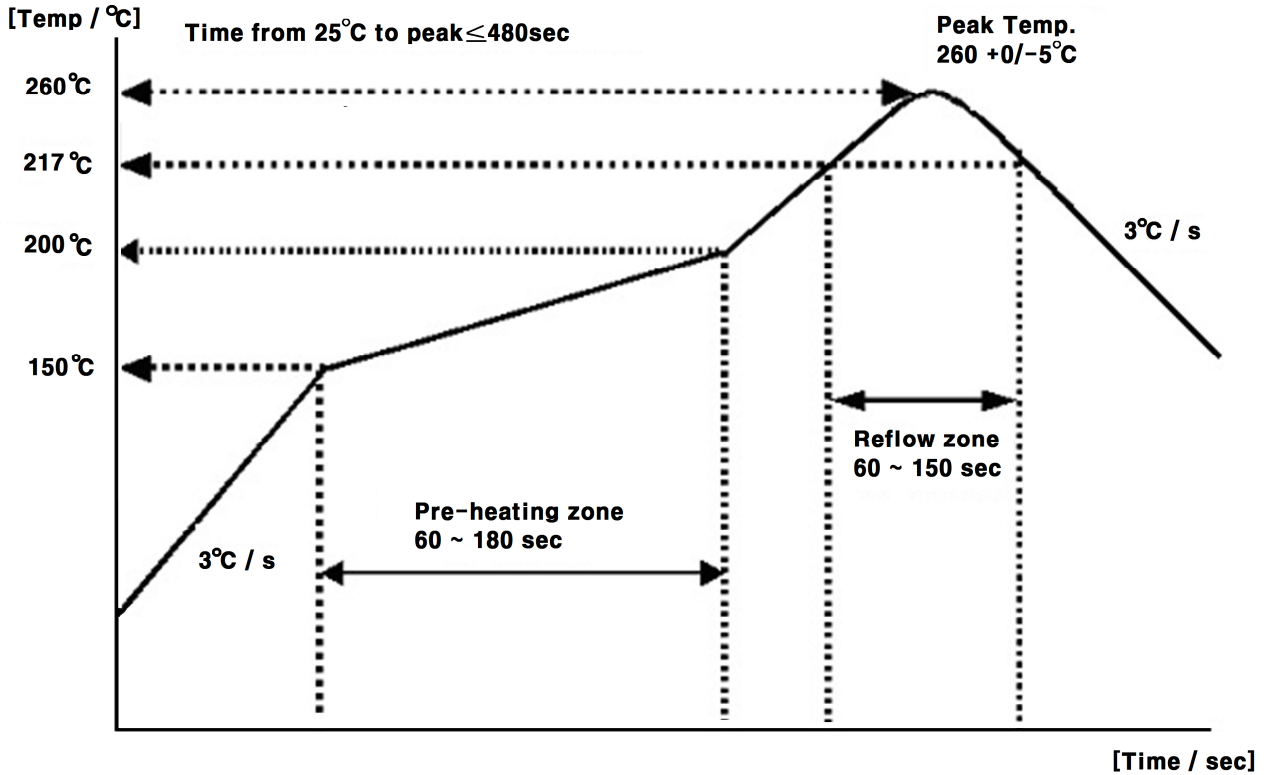

9. RECOMMENDED PCB DIMENSIONS

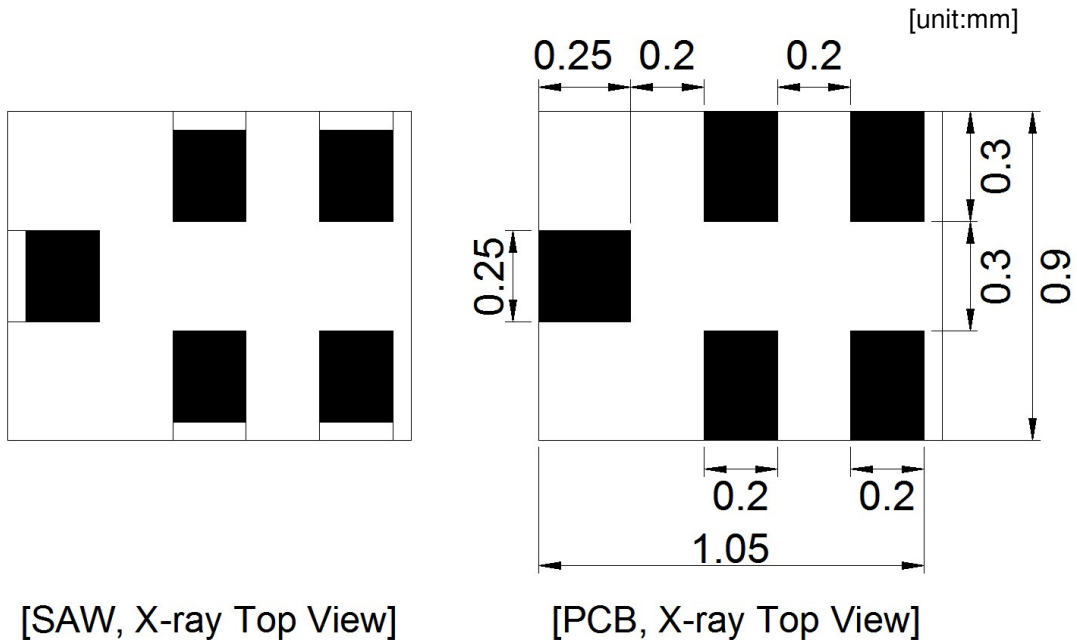

## 10. CAUTION

### Moisture Sensitivity Device Caution (MSL LEVEL=2a)

1. Calculated shelf life in sealed bag : 12 month at <math>\lt; 40^{\circ}\text{C}</math> and <math>\lt; 90\%</math> relative Humidith(RH)
2. Peak package body temperature : **260℃**
3. After bag is opened, devices that will be subjected to reflow solder or other high temperature process must be
  - (a) Mounted within : 672 hours of factory conditions  $\leq 30^{\circ}\text{C}/60\% \text{ RH}$ , or
  - (b) Stored per J-STD-033
4. Device require bake, before mounting, if :
  - (a) Humidity Indicator Card reads  $> 60\%$  when read at  $23 \pm 5^{\circ}\text{C}$
  - (b) 3(a) or 3(b) are not met
5. If baking is requied, refer to IPC/JEDEC J-STD-033 for bake proccedure  
 Note : Level and body temperature defined by IPC/JEDEC J-STD-020

Aluminum Pack (310mmX370mm)



HIC(Humidity Indication Card)

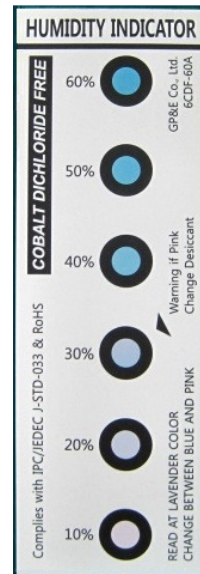

10 to 60% RH

**11. PACKING**

11-1. DIMENSIONS

- Carrier Tape

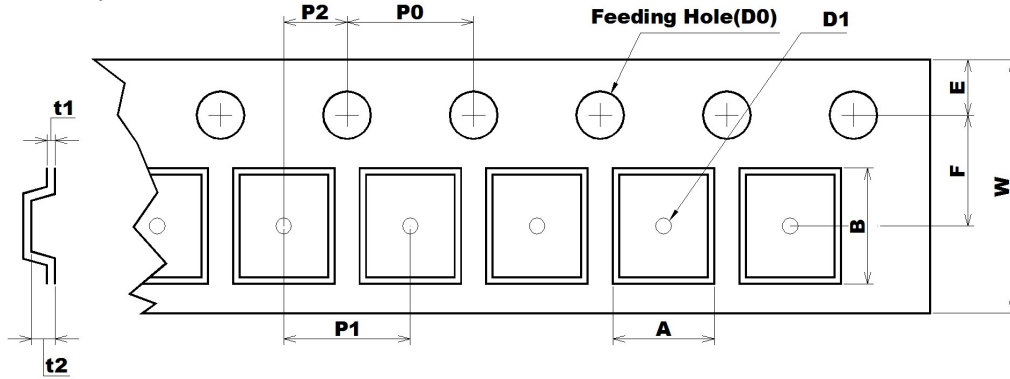

[Unit: mm]

A	B	D0	D1	E	F	P0	P1	P2	t1	t2	W
1.10	1.35	Ø1.50	Ø0.50	1.75	3.50	4.00	4.00	2.00	0.25	0.70	8.00
+0.05	+0.05	+0.10	+0.05	+0.10	+0.05	+0.10	+0.10	+0.05	+0.02	+0.05	+0.30
-0.05	-0.05	-0.00	-0.05	-0.10	-0.05	-0.10	-0.10	-0.05	-0.02	-0.05	-0.10

- Reel

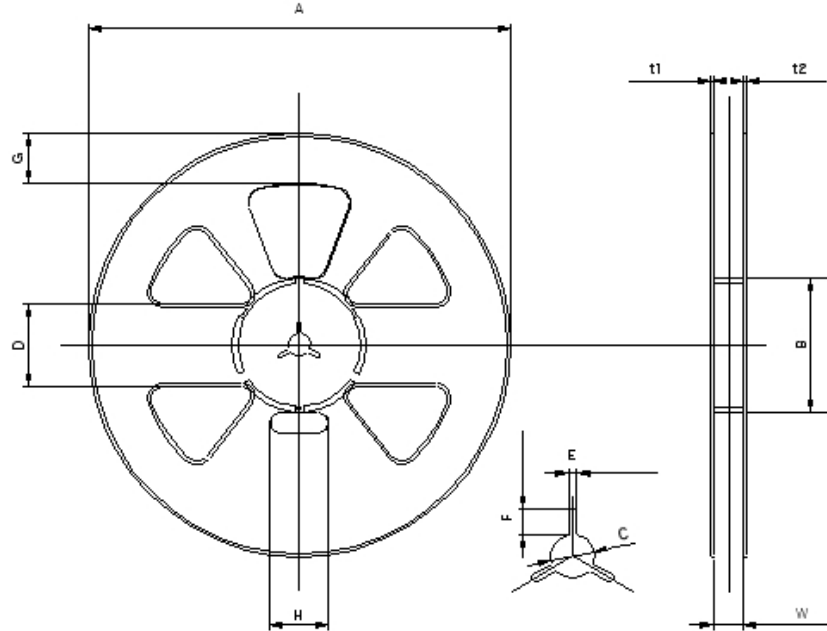

[Unit: mm]

A	B	C	D	E	F	G	H	t1	t2	W
Ø258.0	Ø81.0	Ø13.0	50.0	2.2	7.0	30.0	35.0	1.8	1.5	9.0
+1.0	+1.0	+0.5	+0.8	+0.3	+0.5	+0.8	+1.0	+0.5	+0.5	+1.0
-0.5	-1.0	-0.5	-0.8	-0.3	-0.5	-0.8	-1.0	-0.5	-0.5	-0.5

- The product shall be packed properly not to damaged during transportation and storage.

11-2. REELING QUANTITY

10 inch reel: 10,000 pcs/reel(minimum 10,000 pcs/reel)

11-3. TAPING STRUCTURE

11-3-1. The tape shall be wound around the reel in direction shown below.

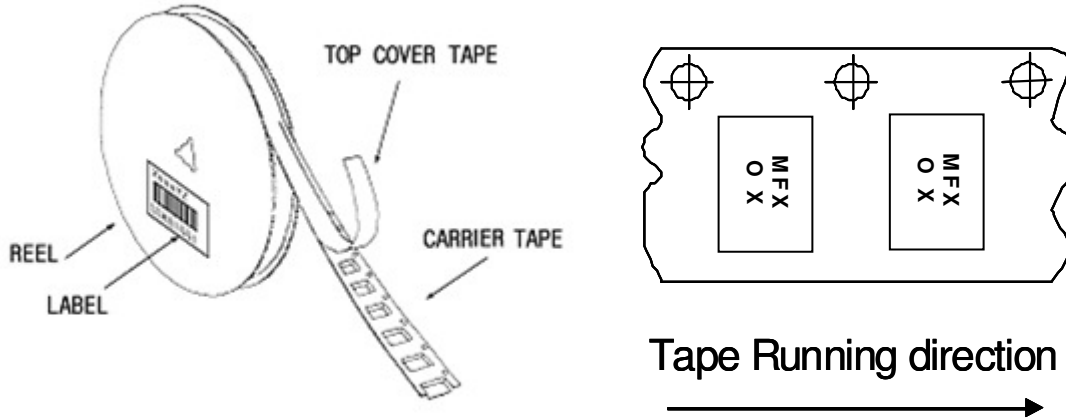

11-3-2. BAR CODE LABEL



- |   |  |
|---|--|
| <ul style="list-style-type: none"> <li>① </li> <li>② SFH836AQ101</li> <li>③ RLYC12563</li> <li>④ 8000 / qAFYU</li> </ul> | <p>MODEL NAME BARCODE</p> <p>Model Name</p> <p>Reel number</p> <p>Quantity / Marking</p> |
|---|--|

11-3-3. Leader part and vacant position specifications.

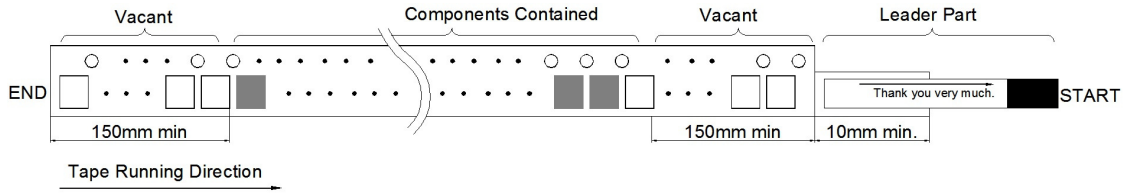

11-4. INNER BOX(Reel Packing) STRUCTURE

Material: Polycarbonate

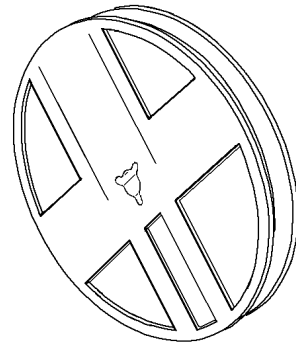

Material: Polyethylene + Aluminium  
Size: 310×370mm<sup>2</sup>

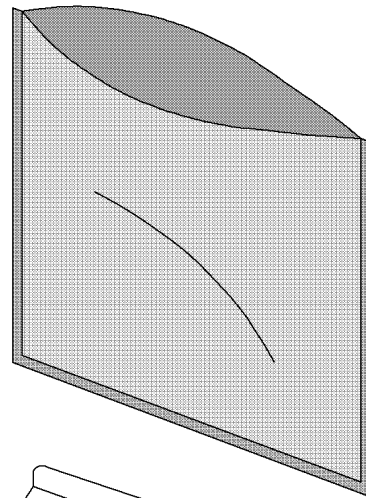

Material: Paper  
Size: (D)260×(W)37×(H)265mm<sup>3</sup>

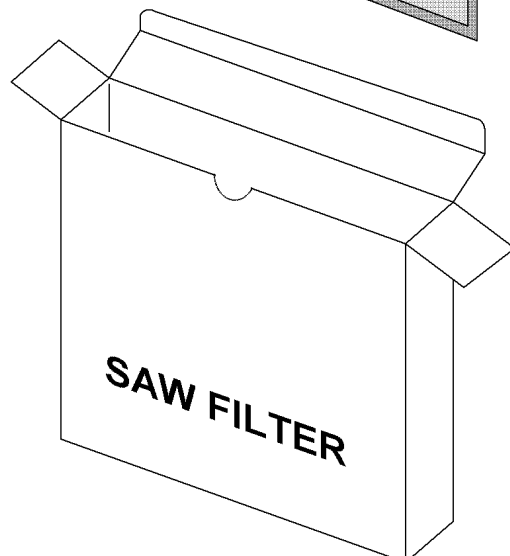



11-5. OUTER BOX STRUCTURE

Material: Paper

TYPE	SIZE(mm)			Inner Box #
	a	b	c	
A	270	240	275	6 boxes

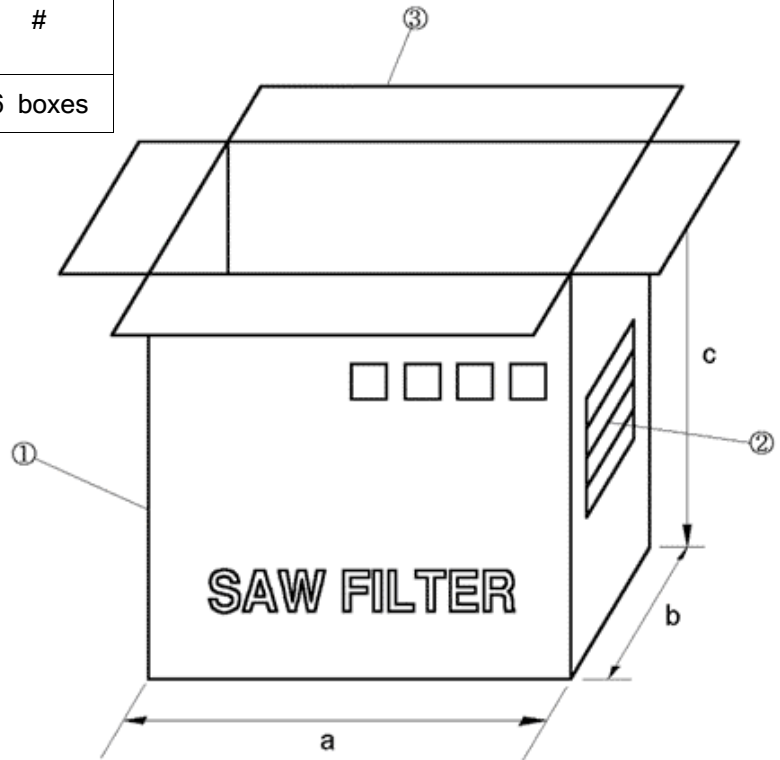

SIDE ①



SIDE ②

MODEL	
Q'TY	EA
USER	
DATE	. . .

- SIDE is the same as front side.

## 12. TAPE SPECIFICATIONS

12-1. Tensile Strength of Carrier Tape: 4.4N/mm width

12-2. Top Cover Tape Adhesion (See the below figure)

- pull of angle: 0~15 degree
- speed: 300mm/min.
- force: 20~70g

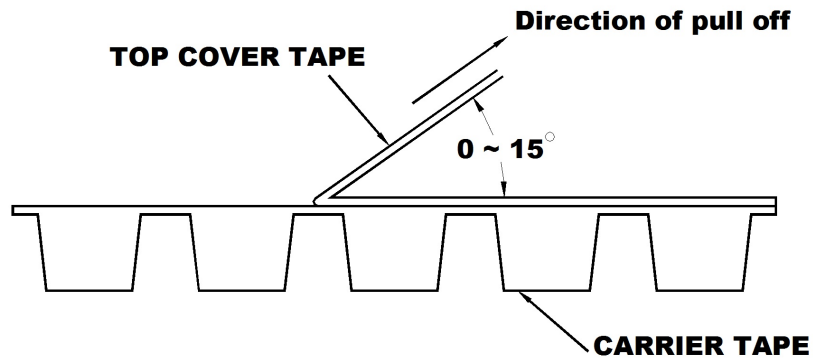

**13. RoHS DATA**



**Test Report No. F690101/LF-CTSAYAA11-28285**

Issued Date: 2011. 09. 06 Page 1 of 2

To: **WISOL CO., LTD.**  
373-7  
Gajang-dong  
Osan-si  
Gyeonggi-do  
Korea

The following merchandise was submitted and identified by the client as :

**SGS File No.** : AYAA11-28285  
**Product Name** : SAW FILTER  
**Item No./Part No.** : N/A  
**Received Date** : 2011. 08. 31  
**Test Period** : 2011. 09. 01 to 2011. 09. 06  
**Test Results** : For further details, please refer to following page(s)  
**Test Performed** : SGS Korea tested the sample(s) selected by applicant with following results.  
**Test Comments** : By the applicant's specific request, the sampling and testing was performed only for the part indicated in the photo without disassembly.

**SGS Korea Co. Ltd.**



**Jeff Jang / Chemical Lab Mgr**

Timothy Jeon  
Jinhee Kim  
Cindy Park  
Jerry Jung/ Testing Person

This document is issued by the Company subject to its General Conditions of Service printed hereafter, available on request or accessible through [www.sgs.com/terms\\_and\\_conditions](http://www.sgs.com/terms_and_conditions) and, for electronic format documents, subject to Terms and Conditions for Electronic Documents at [www.sgs.com/terms\\_e-document.htm](http://www.sgs.com/terms_e-document.htm). Attention is drawn to the limitation of liability, indemnification and jurisdiction issues defined therein. Any holder of this document is advised that it may not constitute a contract. Effects of the Company's findings at the time of its issuance only and within the limits of Client's instructions. If any, the Company's sole responsibility is to its Client and this document does not constitute parties to a transaction from assuming all their rights and obligations under the transaction documents. This document cannot be reproduced except in full, without prior written approval of the Company. Any unauthorized alteration, forgery or falsification of the content or appearance of this document is unlawful and offenders may be prosecuted to the fullest extent of the law. Unless otherwise stated the results shown in this test report refer only to the sample(s) tested and such sample(s) are retained for 90 days only.



**Test Report No.** F690101/LF-CTSAYAA11-28285

Issued Date: 2011. 09. 06 Page 2 of 2

**Sample No.** : AYAA11-28285.001  
**Sample Description** : SAW FILTER  
**Item No./Part No.** : N/A  
**Materials** : N/A

**Heavy Metals**

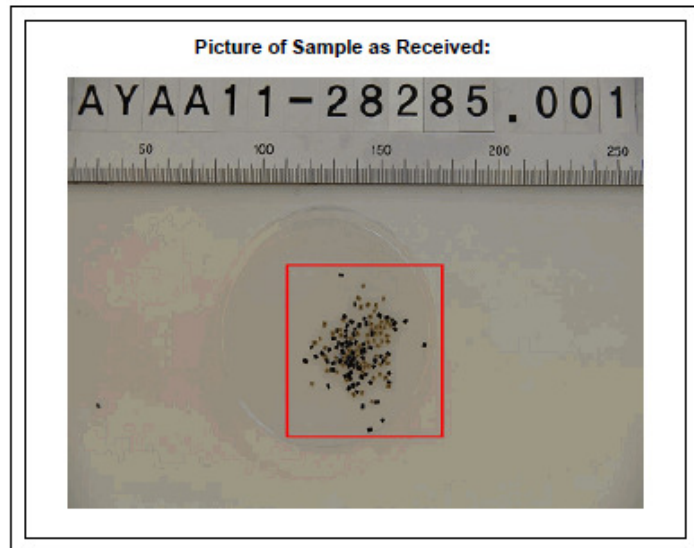
Test Items	Unit	Test Method	MDL	Results
Antimony (Sb)	mg/kg	With reference to EPA 3052(1996), US EPA 6010B(1996), ICP	10	N.D.



\*\*\* End \*\*\*

- NOTE: (1) N.D. = Not detected.(<MDL)  
 (2) mg/kg = ppm  
 (3) MDL = Method Detection Limit  
 (4) - = No regulation  
 (5) \*\* = Qualitative analysis (No Unit)  
 (6) \* = Boiling-water-extraction:  
 Negative = Absence of CrVI coating  
 Positive = Presence of CrVI coating; the detected concentration in boiling-water-extraction solution is equal or greater than 0.02 mg/kg with 50 cm2 sample surface area.

This document is issued by the Company subject to its General Conditions of Service (printed overleaf), available on request or accessible at [www.sgs.com/terms\\_and\\_conditions.html](http://www.sgs.com/terms_and_conditions.html), for electronic format documents, subject to Terms and Conditions for Electronic Documents ([www.sgs.com/terms\\_e-document.htm](http://www.sgs.com/terms_e-document.htm)). Attention is drawn to the limitation of liability, indemnification and jurisdiction clause defined therein. Any holder of this document is advised that information contained herein reflects the Company's findings at the time of its intervention only and within the limits of Clients' instructions. If any, the Company's sole responsibility is to its Client and this document does not exonerate parties to a transaction from exercising all their rights and obligations under the transaction documents. This document cannot be reproduced except in full, without prior written approval of the Company. Any unauthorized alteration, forgery or falsification of the content or appearance of this document is unlawful and offenders may be prosecuted to the fullest extent of the law. Unless otherwise stated the results shown in this test report refer only to the sample(s) tested and such sample(s) are retained for 90 days only.

F052 Version4

SGS Korea Co., Ltd.

 332, The O valley, 555-9, Hogeje-dong, Dongan-gu, Anyang-si, Gyeonggi-do, Korea 431-080  
 T+82 (0)31 4608 000 F+82 (0)31 4608 059 <http://www.sgslab.co.kr> [www.kr.sgs.com/greenlab](http://www.kr.sgs.com/greenlab)

Member of the SGS Group (Société Générale de Surveillance)