



SPECIFICATION

Surface Acoustic Wave Filter

USER



USER PART No.

WISOL PART No. **SFHG96AA402**

DOC. No. SMS-51-L-SFT-FX-102

DATE Feb. 20, 2017

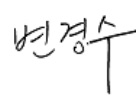
REVISION 000

WISOL					
ISSUED BY	Kim, Woo hyun 	APPROVED BY (R&D)	Byun, Kyung-Su 	APPROVED BY (QC)	Hong, Sang-Dea 
User					
ISSUED BY		CHECKED BY		APPROVED BY	

WISOL CO., LTD.
531-7, Gajang-ro, Osan-si,
Gyeonggi-do, KOREA, 18103
<http://www.wisol.co.kr>

▶ A TABLE OF CONTENTS

1. REVISION HISTORY	3
2. DEFINITION	4
3. PRECAUTIONS.....	4
4. OUTLINE DRAWING & DIMENSIONS.....	5
5. MARKING	6
6. PERFORMANCE.....	7
6-1. MAXIMUM RATINGS	7
6-2. ELECTRICAL CHARACTERISTICS	8
7. RELIABILITY	10
7-1. ENGINEERING SAMPLE FLOW CHART	10
7-2. TEST ITEM & CONDITION	11
8. REFLOW CONDITION	12
9. RECOMMENDED PCB DIMENSIONS	12
10. CAUTION.....	13
11. PACKING.....	14
11-1. DIMENSIONS.....	14
11-2. REELING QUANTITY	15
11-3. TAPING STRUCTURE.....	15
11-4. INNER BOX(Reel Packing) STRUCTURE.....	16
11-5. OUTER BOX STRUCTURE.....	17
12. TAPE SPECIFICATIONS	18
13. RoHS DATA.....	19

1. REVISION HISTORY

000	Feb. 20, 2017	All Page	Make specification
-----	---------------	----------	--------------------

2. DEFINITION

2-1. PART No.

S F H G 9 6 A A 4 0 2

① ② ③ ④ ⑤ ⑥

No.	EXPLANATION
①	SAW Filter
②	Design Type
③	Center Frequency : 2595MHz(2535 ~ 2655)
④	Input:50ohm,Output:50ohm
⑤	Package size: 1.1×0.9mm ²
⑥	Design Revision (02 : Molding Type)

2-2. APPLICATION : Band-Pass Filter for TD LTE B41N Rx etc.

3. PRECAUTIONS

3-1. This device should not be used in any type of fluid such as water, oil, organic solvent, etc.

3-2. This is a hermetic device.

MSL(Moisture Sensitive Level) is the '2a' level.

3-3. Ultrasonic cleaning shall be avoided.

3-4. Isopropyl Alcohol and Ethyl Alcohol can be used for cleaning. Contact us before using other cleaning solvents than above

3-5. This is an electrostatic sensitive device.

Please avoid static voltage during operation and storage.

3-6. Sudden change of temperature shall be avoided, deterioration of the characteristics can occur.

3-7. If any malfunction due to designing or manufacturing which is out of specification occurs within one year after the products have been delivered, the maker should exchange the defective products.

4. OUTLINE DRAWING & DIMENSIONS

[Unit: mm]

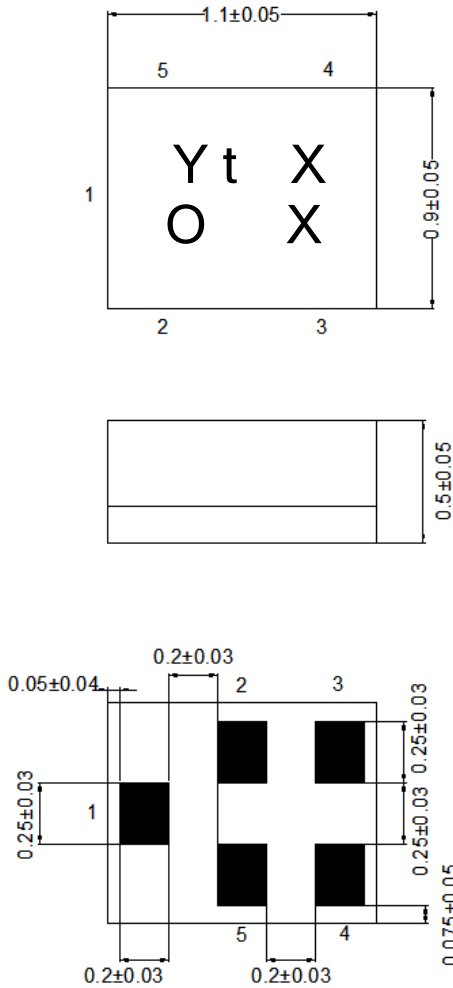

No.	Function
Others	Ground
1	Unbalanced Input
4	Unbalanced Output

5. MARKING

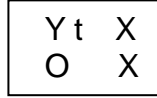

5-1. Y t X X

- The 1st 2nd character 'Yt' indicates the model name of SAW Filter SFHG96AA402.
- The 3rd character 'X' indicates the year and the month of manufacture.

Year	Month											
	1	2	3	4	5	6	7	8	9	10	11	12
2017	1	2	3	4	5	6	7	8	9	A	B	C
2018	D	E	F	G	H	I	J	K	L	M	N	O
2019	P	Q	R	S	T	U	V	W	X	Y	Z	a
2020	1	2	3	4	5	6	7	8	9	A	B	C

※ This rotates by the 3 years.

- The 4th character 'X' indicates Lot No.

5-2. ○

- This symbol indicates input pin 1.
- This indicates the producing center
 - : China

5-3. Marking : Laser Marking

6. PERFORMANCE

6-1. MAXIMUM RATINGS

CHARACTERISTICS	RATINGS	UNITS
DC Permissive Voltage	5	V
Maximum Input Power	15	dBm
Operating Temperature Range	- 30 ~ +85	°C
Storage Temperature Range	- 40 ~ +85	°C

6-2. ELECTRICAL CHARACTERISTICS
6-2-1. TABLE

Ta = - 30 ~ +85℃

Item	FREQUENCY RANGE [MHz]	UNIT	SPECIFICATION		
			Min.	Typ. (25℃)	Max.
Insertion Loss	2535 ~ 2655	dB	-	1.7	2.9
Inband Ripple	2535 ~ 2655	dB	-	0.7	1.8
Input VSWR	2535 ~ 2655	-	-	1.3	2.0
Output VSWR	2535 ~ 2655	-	-	1.4	2.0
Absolute Attenuation	DC ~ 1225	dB	37	42	-
	1225 ~ 1560	dB	30	35	-
	1560 ~ 1610	dB	29	34	-
	1610 ~ 2170	dB	27	32	-
	2170 ~ 2400	dB	30	35	-
	2400 ~ 2473	dB	36	41	-
	2456 ~ 2483	dB	36	41	-
	2750 ~ 4900	dB	23	28	-
	4900 ~ 6000	dB	27	32	-
	5070 ~ 5310	dB	28	33	-
Termination Impedance		Input: Unbalanced 50 Ohm // 3.8nH Output: Unbalanced 50 Ohm // 3.8nH			

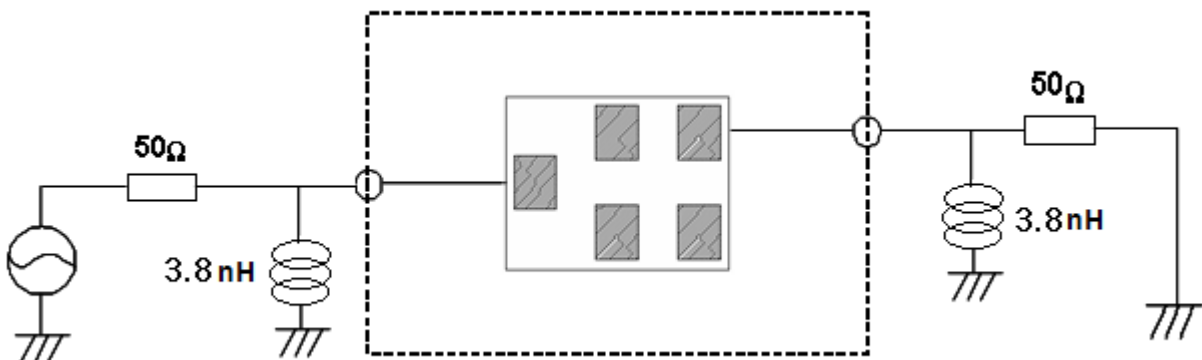
6-2-2. TEST FIXTURE

[X-Ray Top View]

6-2-3. GRAPH

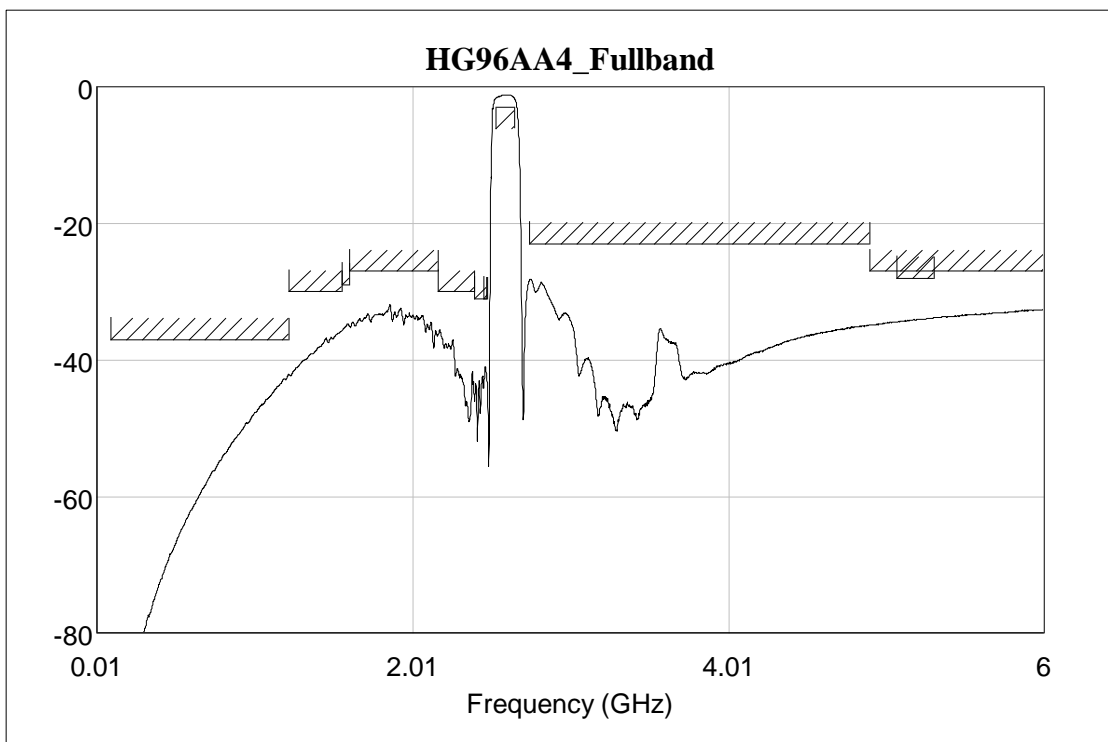
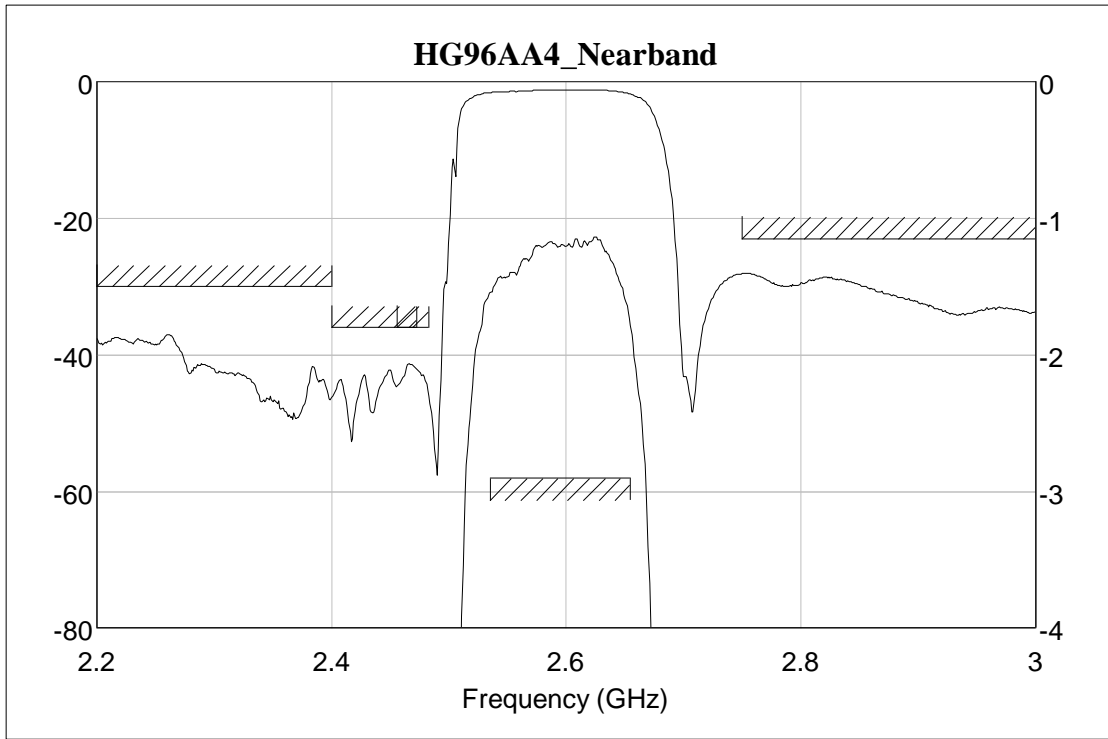

7. RELIABILITY

7-1. ENGINEERING SAMPLE FLOW CHART

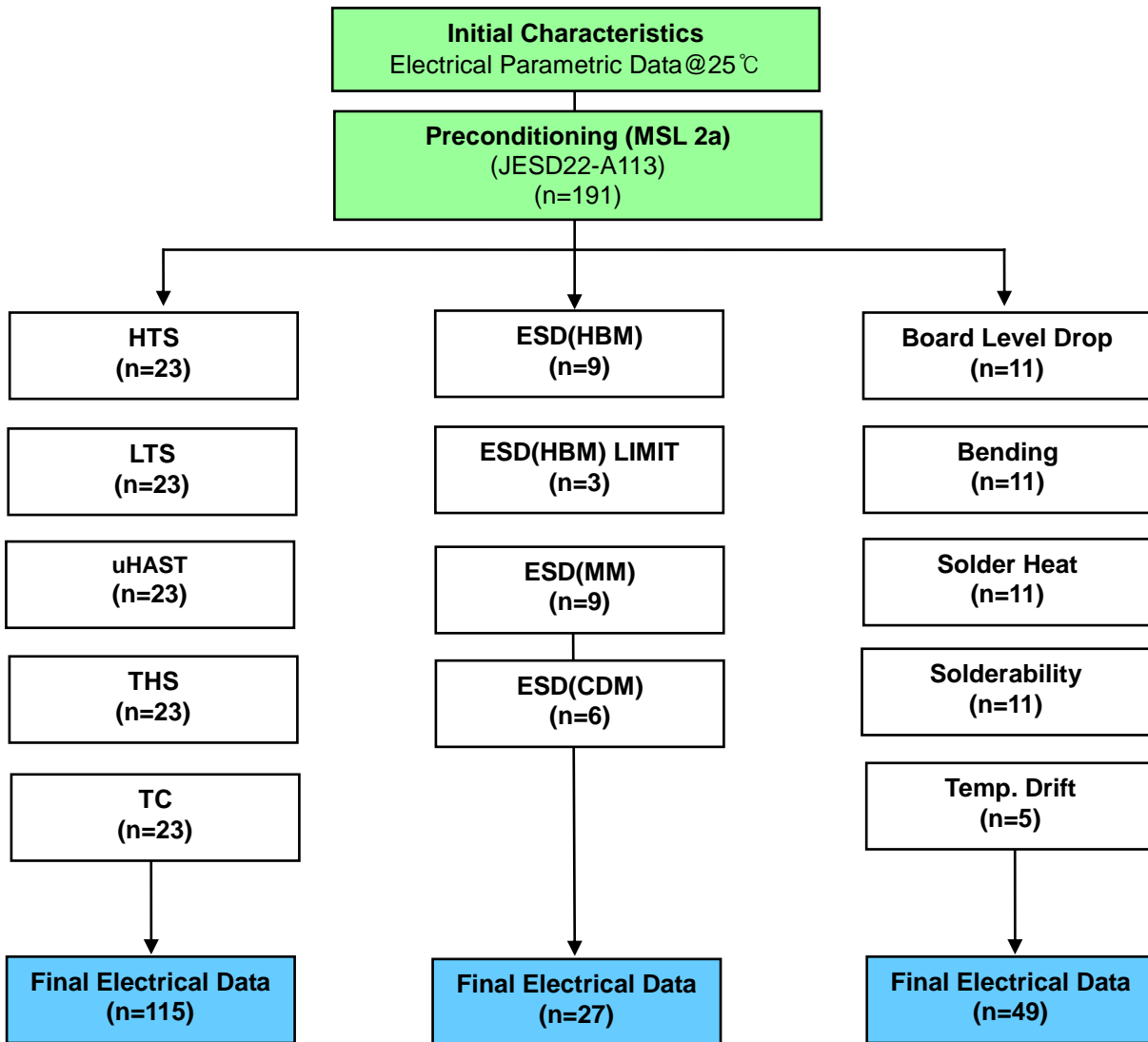

7-2. TEST ITEM & CONDITION

CATEGORY	TEST ITEM	TEST CONDITION	REMARK
	Preconditioning	Bake + Soak(MSL or above) + 3X Reflow duration (Soak 60°C 60% 120HR)	JESD22-A113



TEST ITEM	REMARK	TEST CONDITION	Duration
HTS (High Temperature Storage)	JESD22-A103	condition A 125(-0/+10)°C	1000hr
LTS (Low Temperature Storage)	JESD22-A119	A -40(-10/+0)°C	1000hr
uHAST (Unbiased HAST)	JESD22-A118	130°C /85% /33.3psi	96hr
THS (Temperature Humidity Storage)	JESD22-A101	85°C /85% RH	1000hr
TC (Temperature Cycle)	JESD22-A104	Condition G (-40°C /125°C)	1000cycle
ESD(HBM)	JESD22-A114	250V or above	-
ESD(HBM) LIMIT	-	300V or above	-
ESD(MM)	JESD22-A115	No spec but need data	-
ESD(CDM)	JESD22-C101	500V or above	-
Board Level Drop Test	JESD22-B111	1500G Duration 0.5ms	150cycle
Bending Test		0.5mm/sec 3times (1mm distance)	
Solder Heat Resistance		260°C	10sec
Solderability		235°C	3sec
Temp Drift		-40°C → +25°C → +125°C	Per conditions 2HR

8. REFLOW CONDITION

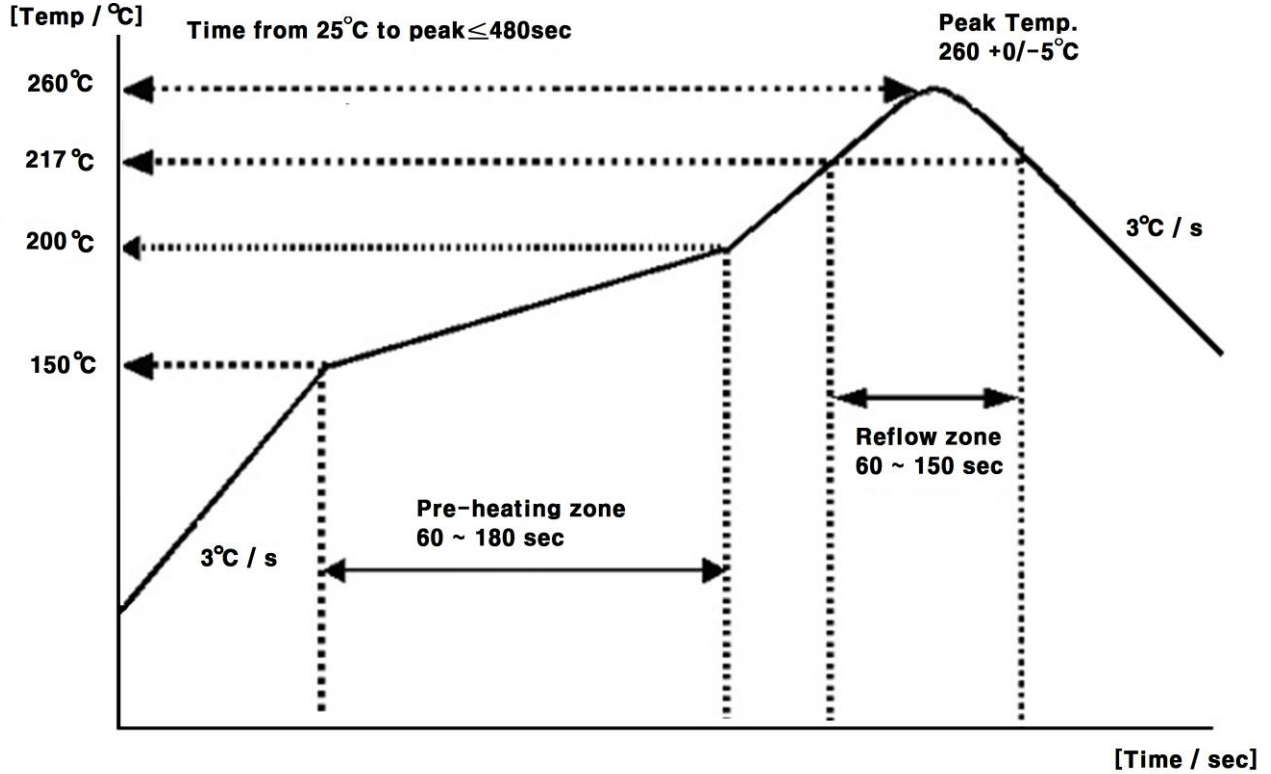

9. RECOMMENDED PCB DIMENSIONS

[unit : mm]

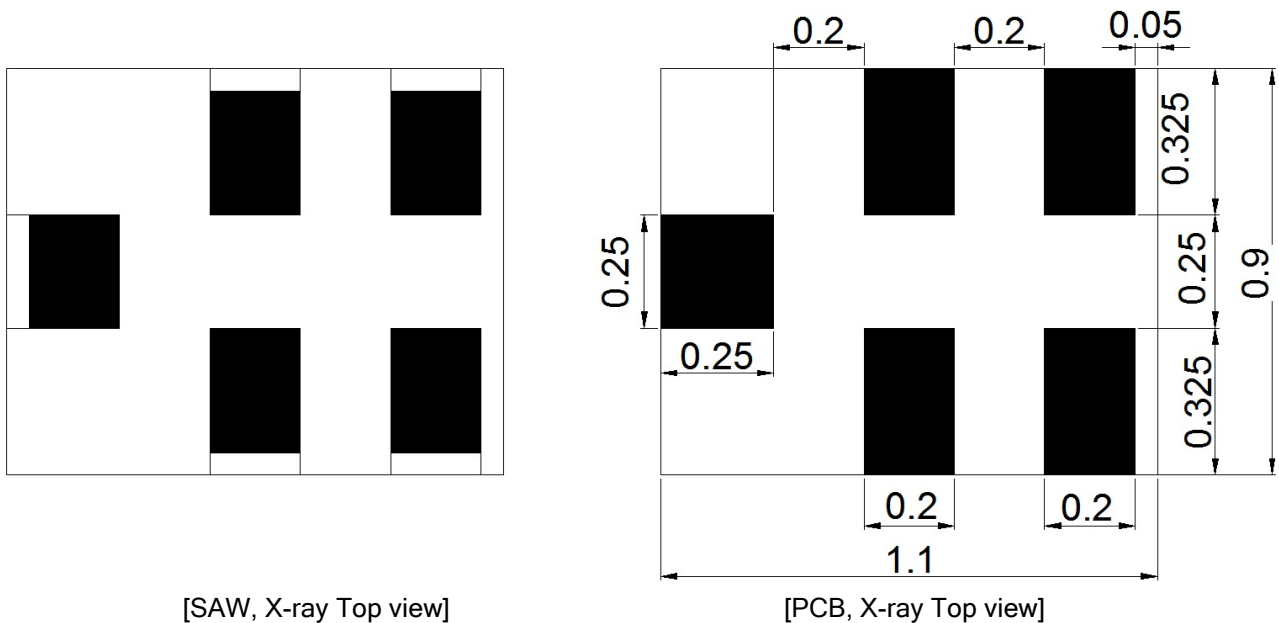

10. CAUTION

Moisture Sensitivity Device Caution (MSL LEVEL=2a)

1. Calculated shelf life in sealed bag : 12 month at < 40℃ and < 90% relative Humidity(RH)
 2. Peak package body temperature : **260℃**
 3. After bag is opened, devices that will be subjected to reflow solder or other high temperature process must be
 - (a) Mounted within : 672 hours of factory conditions ≤30℃/60% RH, or
 - (b) Stored per J-STD-033
 4. Device require bake, before mounting, if :
 - (a) Humidity Indicator Card reads > 60% when read at 23±5℃
 - (b) 3(a) or 3(b) are not met
 5. If baking is required, refer to IPC/JEDEC J-STD-033 for bake procedure
- Note : Level and body temperature defined by IPC/JEDEC J-STD-020

Aluminum Pack (310mmX370mm)



HIC(Humidity Indication Card)

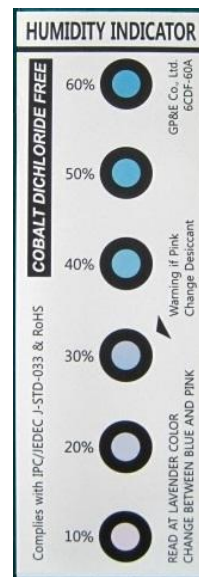

10 to 60% RH

11. PACKING

11-1. DIMENSIONS

- Carrier Tape

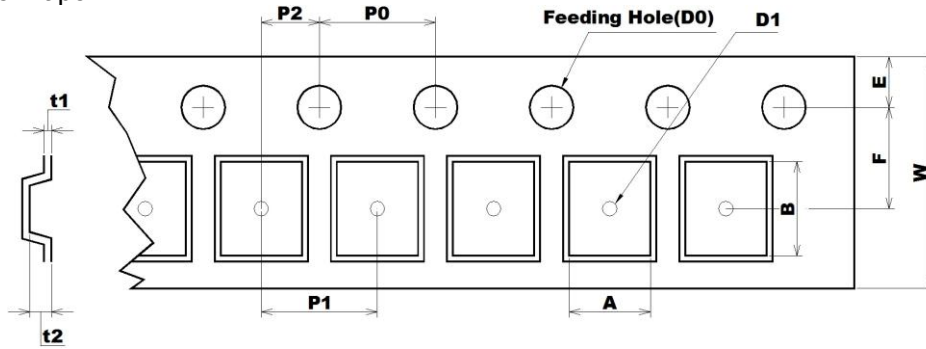

[Unit: mm]

A	B	D0	D1	E	F	P0	P1	P2	t1	t2	W
1.08	1.23	Ø1.50	Ø0.50	1.75	3.50	4.00	4.00	2.00	0.23	0.70	8.00
+0.05	+0.05	+0.10	+0.01	+0.10	+0.05	+0.05	+0.05	+0.05	+0.05	+0.05	+0.30
-0.05	-0.05	-0.00		-0.10	-0.05	-0.05	-0.05	-0.05	-0.05	-0.05	-0.10

- Reel

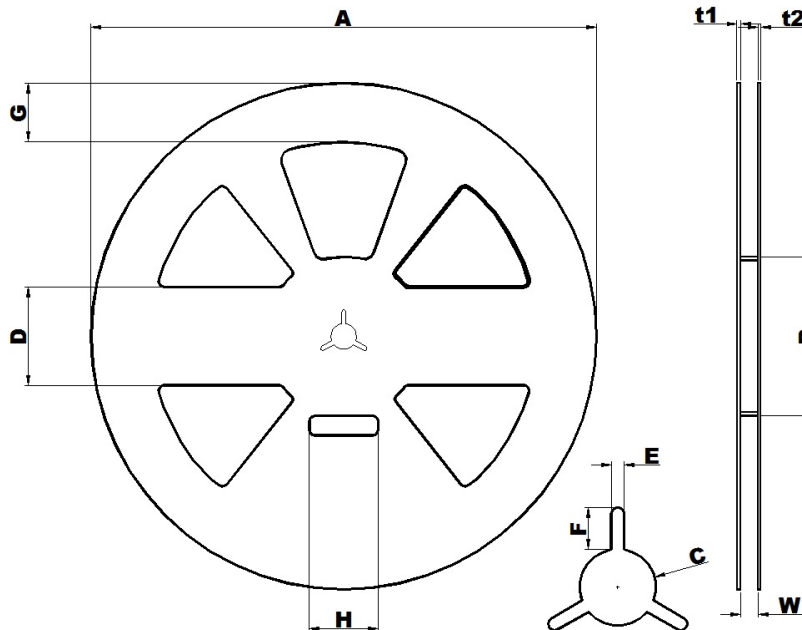

[Unit: mm]

A	B	C	D	E	F	G	H	t1	t2	W
Ø258.0	Ø81.0	Ø13.0	50.0	2.2	7.0	30.0	35.0	1.8	1.5	9.0
+1.0	+1.0	+0.5	+0.8	+0.3	+0.5	+0.8	+1.0	+0.5	+0.5	+1.0
-0.5	-1.0	-0.5	-0.8	-0.3	-0.5	-0.8	-1.0	-0.5	-0.5	-0.5

- The product shall be packed properly not to damaged during transportation and storage.

11-2. REELING QUANTITY

10 inch reel : 10,000 pcs/reel

11-3. TAPING STRUCTURE

11-3-1. The tape shall be wound around the reel in direction shown below.

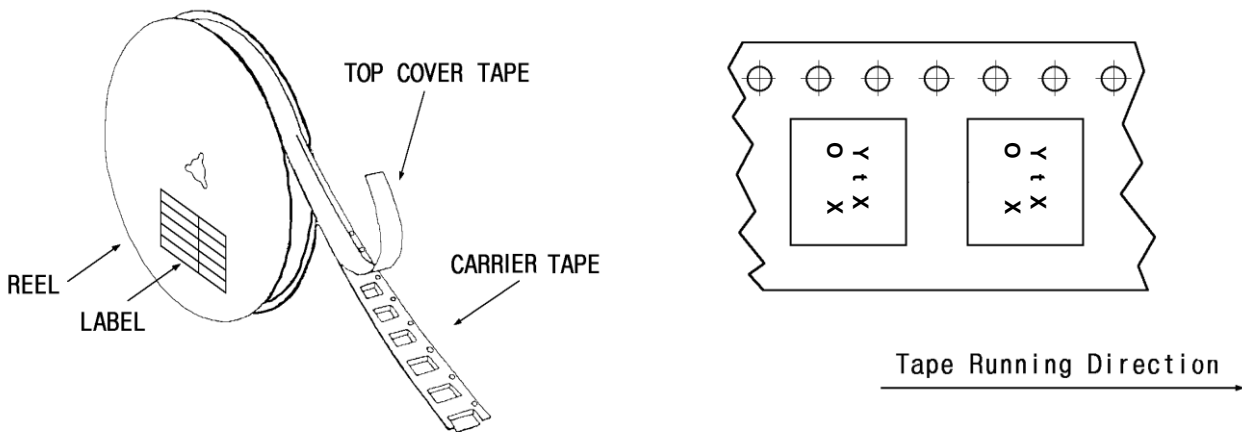
11-3-2. BARCODE LABEL

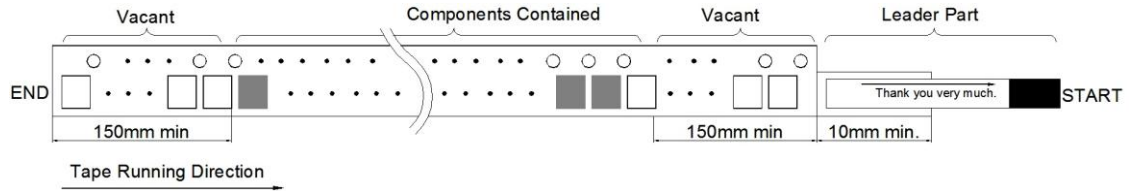

①	MODEL NAME BARCODE
②	Model Name
③	Reel number
④	Quantity / Marking

1-3-3. Leader part and vacant position specifications.

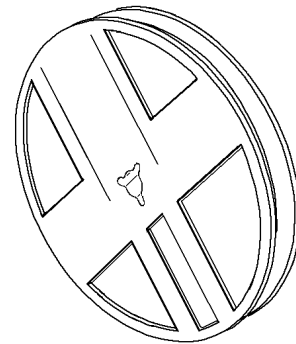

11-4. INNER BOX(Reel Packing) STRUCTURE

Material: Polycarbonate



Material : Polyethylene + Aluminium
Size : 310×370mm²

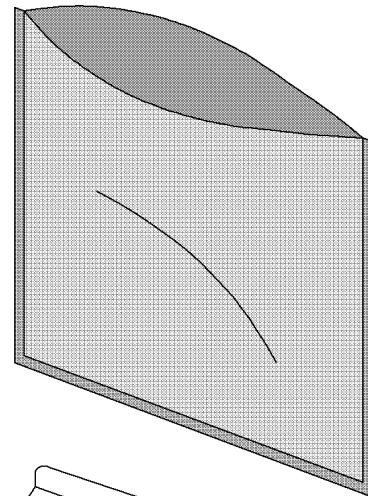

Material : Paper
Size: (D)260×(W)37×(H)265mm³

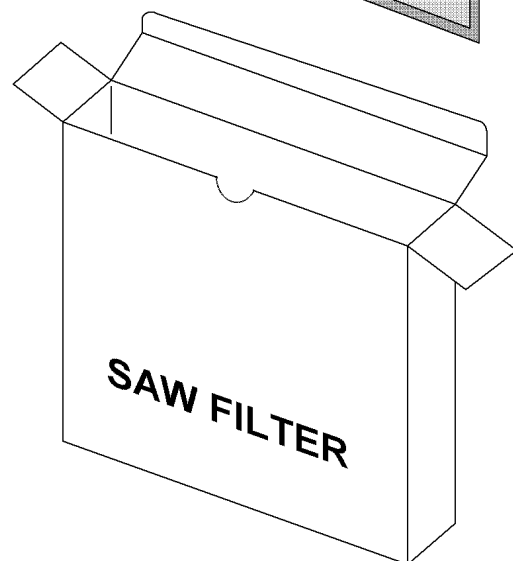

11-5. OUTER BOX STRUCTURE

Material : Paper

TYPE	SIZE(mm)			Inner Box #
	a	b	c	
A	270	240	275	6 boxes

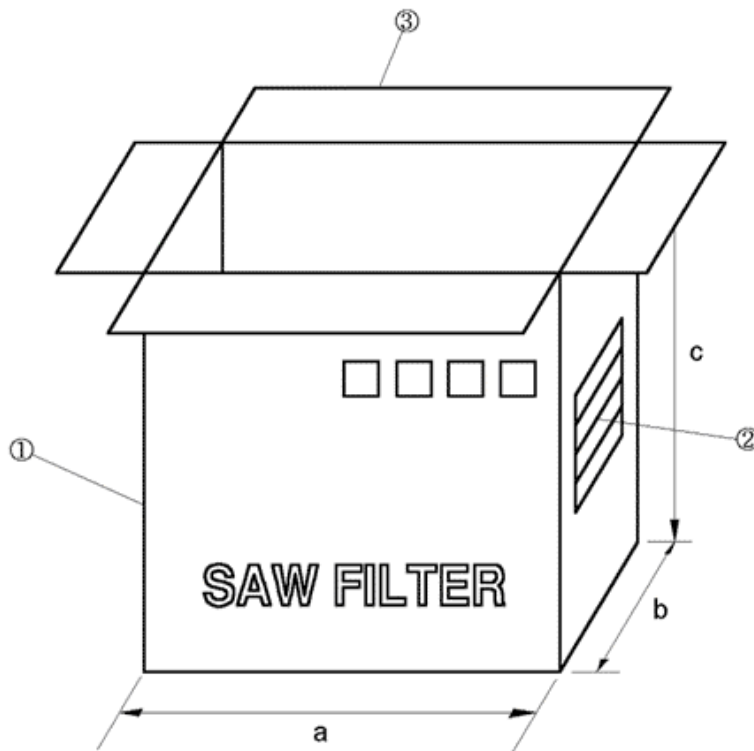

SIDE ①

SIDE ②

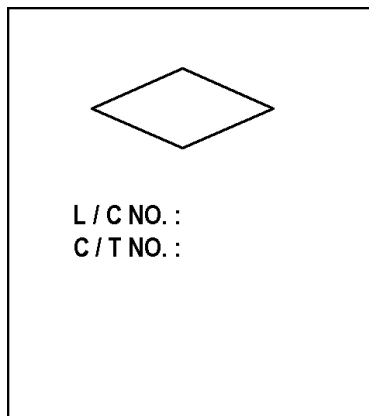

MODEL	
Q'TY	EA
USER	
DATE	. .

- SIDE is the same as front side.

12. TAPE SPECIFICATIONS

12-1. Tensile Strength of Carrier Tape: 4.4N/mm width

12-2. Top Cover Tape Adhesion (See the below figure)

- pull of angle: 0~15 degree
- speed: 300mm/min.
- force: 20~70g

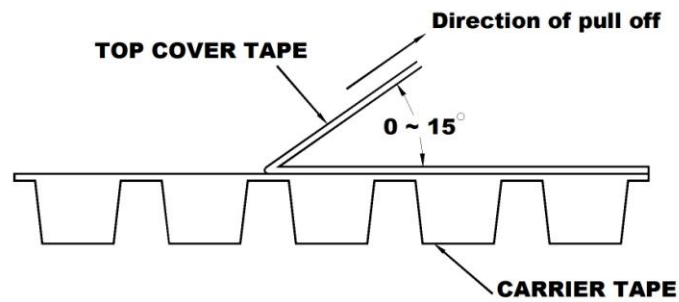

13. RoHS DATA



Test Report No. F690101/LF-CTSAYAA15-37174

Issued Date : 2015. 07. 20

Page 1 of 7

WISOL CO., LTD.
28-40, Gajangsaneopdong-ro
Osan-si, Gyeonggi-do
Korea

The following sample(s) was/were submitted and identified by/on behalf of the client as:-

SGS File No.	: AYAA15-37174
Product Name	: SAW FILTER
Item No./Part No.	: N/A
Buyer(s)	: SAMSUNG
Received Date	: 2015. 07. 15
Test Period	: 2015. 07. 15 to 2015. 07. 20
Test Comments	: By the applicant's specific request, the sampling and testing was performed only for the part indicated in the photo without disassembly.
Test Results	: For further details, please refer to following page(s)

SGS Korea Co., Ltd.



Jeff Jang / Chemical Lab Mgr

This document is issued by the Company subject to its General Conditions of Service printed overleaf, available on request or accessible at <http://www.sgs.com/ro/terms-and-conditions.aspx> and, for electronic format documents, subject to Terms and Conditions for Electronic Documents at www.sgs.com/terms_e-document.htm http://www.sgs.com/terms_e-document.htm. Attention is drawn to the limitation of liability, indemnification and jurisdiction issues defined therein. Any holder of this document is advised that information contained herein reflects the Company's findings at the time of its intervention only and within the limits of Client's instructions, if any. The Company's sole responsibility is to its Client and this document does not exonerate parties to a transaction from exercising all their rights and obligations under the transaction documents. This document cannot be reproduced except in full, without prior written approval of the Company. Any unauthorized alteration, forgery or falsification of the content or appearance of this document is unlawful and offenders may be prosecuted to the fullest extent of the law. Unless otherwise stated the results shown in this test report refer only to the sample(s).

SGS Korea Co., Ltd. 322, The Ovalley, 76, LS-ro, Dongan-gu, Anyang-si, Gyeonggi-do, Korea 431-000
t +82 (0)31 4608 000 f +82 (0)31 4608 055 <http://www.sgs.com>

F401 Version2

Member of the SGS Group (Société Générale de Surveillance)



Test Report No. F690101/LF-CTSAYAA15-37174

Issued Date : 2015. 07. 20

Page 2 of 7

Sample No. : AYAA15-37174.001
 Sample Description : SAW FILTER
 Item No./Part No. : N/A
 Materials : HTCC,GOLD,EPOXY,LT

Heavy Metals

Test Items	Unit	Test Method	MDL	Results
Cadmium (Cd)	mg/kg	With reference to IEC 62321-5:2013 (Determination of Cadmium by ICP-OES)	0.5	N.D.
Lead (Pb)	mg/kg	With reference to IEC 62321-5:2013 (Determination of Lead by ICP-OES)	5	N.D.
Mercury (Hg)	mg/kg	With reference to IEC 62321-4:2013 (Determination of Mercury by ICP-OES)	2	N.D.
Hexavalent Chromium (Cr VI)	mg/kg	With reference to IEC 62321:2008 (Determination of Hexavalent Chromium by spot test/Colorimetric Method using UV-Vis)	1	N.D.
Antimony (Sb)	mg/kg	With reference to EPA 3052(1996), US EPA 6010B(1996), ICP	10	N.D.

Flame Retardants-PBBs/PBDEs

Test Items	Unit	Test Method	MDL	Results
Monobromobiphenyl	mg/kg	With reference to IEC 62321:2008 (Determination of PBBs and PBDEs by GC-MS)	5	N.D.
Dibromobiphenyl	mg/kg	With reference to IEC 62321:2008 (Determination of PBBs and PBDEs by GC-MS)	5	N.D.
Tribromobiphenyl	mg/kg	With reference to IEC 62321:2008 (Determination of PBBs and PBDEs by GC-MS)	5	N.D.
Tetrabromobiphenyl	mg/kg	With reference to IEC 62321:2008 (Determination of PBBs and PBDEs by GC-MS)	5	N.D.
Pentabromobiphenyl	mg/kg	With reference to IEC 62321:2008 (Determination of PBBs and PBDEs by GC-MS)	5	N.D.
Hexabromobiphenyl	mg/kg	With reference to IEC 62321:2008 (Determination of PBBs and PBDEs by GC-MS)	5	N.D.
Heptabromobiphenyl	mg/kg	With reference to IEC 62321:2008 (Determination of PBBs and PBDEs by GC-MS)	5	N.D.
Octabromobiphenyl	mg/kg	With reference to IEC 62321:2008 (Determination of PBBs and PBDEs by GC-MS)	5	N.D.
Nonabromobiphenyl	mg/kg	With reference to IEC 62321:2008 (Determination of PBBs and PBDEs by GC-MS)	5	N.D.
Decabromobiphenyl	mg/kg	With reference to IEC 62321:2008 (Determination of PBBs and PBDEs by GC-MS)	5	N.D.
Monobromodiphenyl ether	mg/kg	With reference to IEC 62321:2008 (Determination of PBBs and PBDEs by GC-MS)	5	N.D.
Dibromodiphenyl ether	mg/kg	With reference to IEC 62321:2008 (Determination of PBBs and PBDEs by GC-MS)	5	N.D.
Tribromodiphenyl ether	mg/kg	With reference to IEC 62321:2008 (Determination of PBBs and PBDEs by GC-MS)	5	N.D.

This document is issued by the Company subject to its General Conditions of Service printed overleaf, available on request or accessible at <http://www.sgs.com/en/Terms-and-Conditions.aspx> and, for electronic format documents, subject to Terms and Conditions for Electronic Documents # http://www.sgs.com/en/sgs_electronic_documents.html. Attention is drawn to the limitation of liability, indemnification and jurisdiction issues defined therein. Any holder of this document is advised that information contained herein reflects the Company's findings at the time of its intervention only and within the limits of Client's instructions, if any. The Company's sole responsibility is to its Client and this document does not constitute parties to a transaction from exercising all their rights and obligations under the transaction documents. This document cannot be reproduced except in full, without prior written approval of the Company. Any unauthorized alteration, forgery or falsification of the content or appearance of this document is unlawful and offenders may be prosecuted to the fullest extent of the law. Unless otherwise stated the results shown in this test report refer only to the sample(s).

SGS Korea Co., Ltd. | 322, The C Valley, 76, LS-ro, Dongen-gu, Anyang-si, Gyeonggi-do, Korea 431-000
 t +82 (0)31 4608 0000 f +82 (0)31 4608 0500 <http://www.sgskorea.kr>

F401 Version2

Member of the SGS Group (Société Générale de Surveillance)



Test Report No. F690101/LF-CTSAYAA15-37174

Issued Date : 2015. 07. 20

Page 3 of 7

Sample No. : AYAA15-37174.001
 Sample Description : SAW FILTER
 Item No./Part No. : N/A
 Materials : HTCC,GOLD,EPOXY,LT

Flame Retardants-PBBs/PBDEs

Test Items	Unit	Test Method	MDL	Results
Tetrabromodiphenyl ether	mg/kg	With reference to IEC 62321:2008 (Determination of PBBs and PBDEs by GC-MS)	5	N.D.
Pentabromodiphenyl ether	mg/kg	With reference to IEC 62321:2008 (Determination of PBBs and PBDEs by GC-MS)	5	N.D.
Hexabromodiphenyl ether	mg/kg	With reference to IEC 62321:2008 (Determination of PBBs and PBDEs by GC-MS)	5	N.D.
Heptabromodiphenyl ether	mg/kg	With reference to IEC 62321:2008 (Determination of PBBs and PBDEs by GC-MS)	5	N.D.
Octabromodiphenyl ether	mg/kg	With reference to IEC 62321:2008 (Determination of PBBs and PBDEs by GC-MS)	5	N.D.
Nonabromodiphenyl ether	mg/kg	With reference to IEC 62321:2008 (Determination of PBBs and PBDEs by GC-MS)	5	N.D.
Decabromodiphenyl ether	mg/kg	With reference to IEC 62321:2008 (Determination of PBBs and PBDEs by GC-MS)	5	N.D.

Halogen Content

Test Items	Unit	Test Method	MDL	Results
Bromine(Br)	mg/kg	With reference to EN 14582, IC	30	N.D.
Chlorine(Cl)	mg/kg	With reference to EN 14582, IC	30	N.D.

- NOTE: (1) N.D. = Not detected (<MDL)
 (2) mg/kg = ppm
 (3) MDL = Method Detection Limit
 (4) - = No regulation
 (5) Negative = Undetectable / Positive = Detectable
 (6) ** = Qualitative analysis (No Unit)
 (7) * = Boiling-water-extraction:
 Negative = Absence of CrVI coating
 Positive = Presence of CrVI coating; the detected concentration in boiling-water-extraction solution is equal or greater than 0.02 mg/kg with 50 cm² sample surface area.

This document is issued by the Company subject to its General Conditions of Service printed overleaf, available on request or accessible at <http://www.sgs.com/en/Terms-and-Conditions.aspx> and, for electronic format documents, subject to Terms and Conditions for Electronic Documents at <http://www.sgs.com/en/Terms-and-Conditions.aspx>. Attention is drawn to the limitation of liability, indemnification and jurisdiction issues defined therein. Any holder of this document is advised that information contained herein reflects the Company's findings at the time of its intervention only and within the limits of Client's instructions, if any. The Company's sole responsibility is to its Client and this document does not exonerate parties to a transaction from exercising all their rights and obligations under the transaction documents. This document cannot be reproduced except in full, without prior written approval of the Company. Any unauthorized alteration, forgery or falsification of the content or appearance of this document is unlawful and offenders may be prosecuted to the fullest extent of the law. Unless otherwise stated the results shown in this test report refer only to the sample(s).

SGS Korea Co., Ltd. | 322, The C valley, 76, LS-ro, Dongan-gu, Anyang-si, Gyeonggi-do, Korea 431-000
 t +82 (0)31 4608 000 f +82 (0)31 4608 059 <http://www.sgskorea.kr>

F401 Version2

Member of the SGS Group (Société Générale de Surveillance)



Test Report No. F690101/LF-CTSAYAA15-37174

Issued Date : 2015. 07. 20

Page 4 of 7

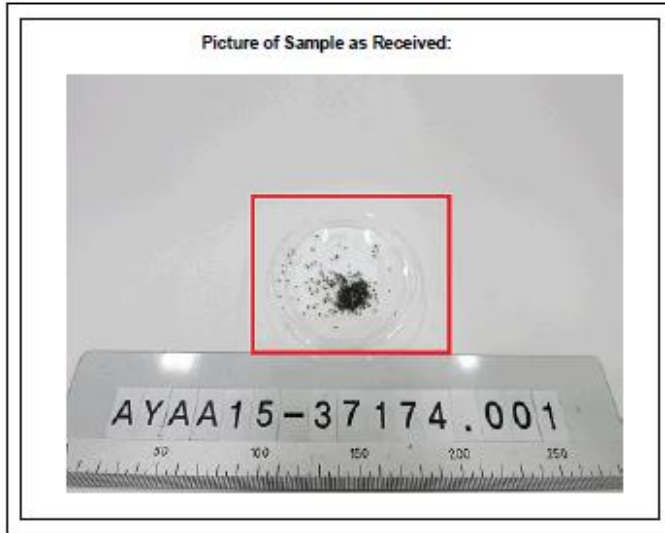

This document is issued by the Company subject to its General Conditions of Service printed overleaf, available on request or accessible at <http://www.sgs.com/kr/Terms-and-Conditions.aspx> and, for electronic format documents, subject to Terms and Conditions for Electronic Documents at http://www.sgs.com/kr/Terms_e-document.htm. Attention is drawn to the limitation of liability, indemnification and jurisdiction issues defined therein. Any holder of this document is advised that information contained herein reflects the Company's findings at the time of its intervention only and within the limits of Client's instructions, if any. The Company's sole responsibility is to its Client and this document does not exonerate parties to a transaction from exercising all their rights and obligations under the transaction documents. This document cannot be reproduced except in full, without prior written approval of the Company. Any unauthorized alteration, forgery or falsification of the content or appearance of this document is unlawful and offenders may be prosecuted to the fullest extent of the law. Unless otherwise stated the results shown in this test report refer only to the sample(s).

SGS Korea Co., Ltd

322, The C-valley, 76, LS-ro, Dongan-gu, Anyang-si, Gyeonggi-do, Korea 431-000
t +82 (0)31 4606 000 f +82 (0)31 4606 055 <http://www.sgs.com/kr>

F401 Version2

Member of the SGS Group (Société Générale de Surveillance)



Test Report No. F690101/LF-CTSAYAA15-37174

Issued Date : 2015. 07. 20

Page 5 of 7

Testing Flow Chart for RoHS: Cd/Pb/Hg/Cr⁶⁺ /PBBs&PBDEs Testing

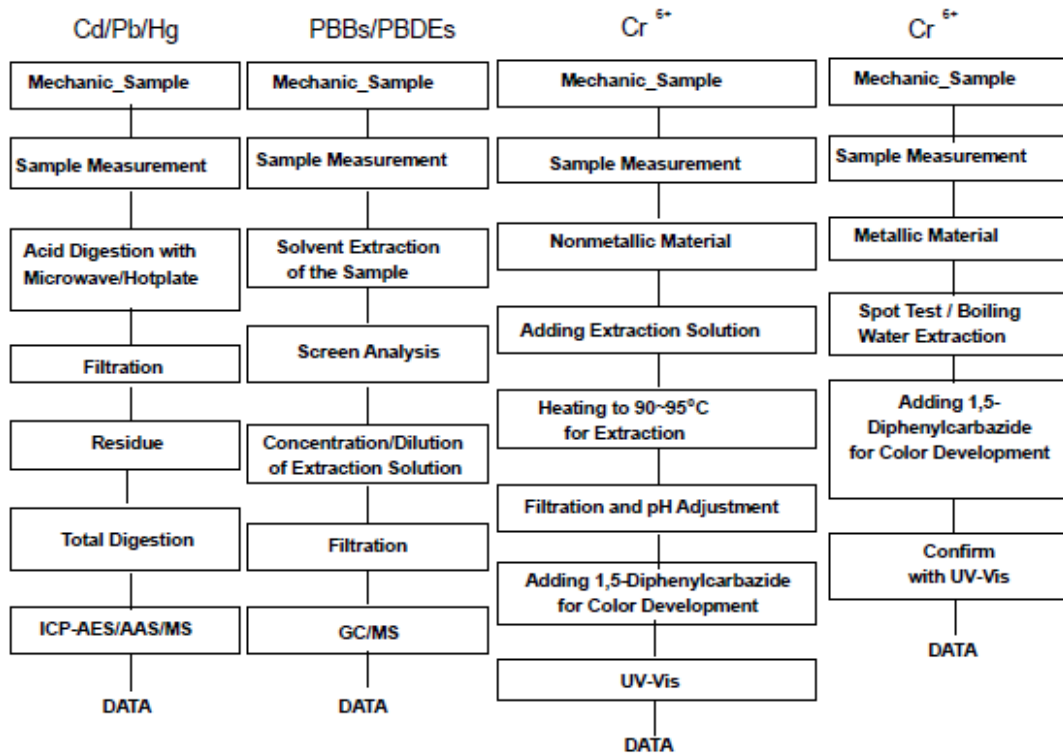

The samples were dissolved totally by pre-conditioning method according to above flow chart for Cd,Pb,Hg.
Section Chief : Gilsae Yi

This document is issued by the Company subject to its General Conditions of Service printed overleaf, available on request or accessible at <http://www.sgs.com/en/Terms-and-Conditions.aspx> and, for electronic format documents, subject to Terms and Conditions for Electronic Documents at http://www.sgs.com/en/terms_electronic.html. Attention is drawn to the limitation of liability, indemnification and jurisdiction issues defined therein. Any holder of this document is advised that information contained herein reflects the Company's findings at the time of its intervention only and within the limits of Client's instructions, if any. The Company's sole responsibility is to its Client and this document does not constitute parties to a transaction from exercising all their rights and obligations under the transaction documents. This document cannot be reproduced except in full, without prior written approval of the Company. Any unauthorized alteration, forgery or falsification of the content or appearance of this document is unlawful and offenders may be prosecuted to the fullest extent of the law. Unless otherwise stated the results shown in this test report refer only to the sample(s).



Test Report No. F690101/LF-CTSAYAA15-37174

Issued Date : 2015. 07. 20

Page 6 of 7

Flow Chart for Inorganic Elements Testing

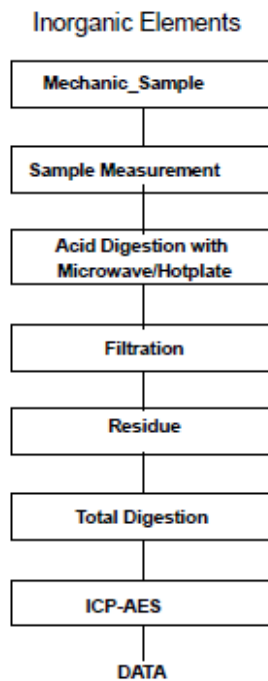

Major Inorganic Heavy Metals	Antimony(Sb) , Beryllium(Be) , Phosphorus(P) , Arsenic(As) etc.
------------------------------	---

This document is issued by the Company subject to its General Conditions of Service printed overleaf, available on request or accessible at <http://www.sgs.com/ko/Terms-and-Conditions.aspx> and, for electronic format documents, subject to Terms and Conditions for Electronic Documents at www.sgs.com/ko/Terms-and-Conditions.aspx and <http://www.sgs.com/ko/Terms-and-Conditions.aspx>. Attention is drawn to the limitation of liability, indemnification and jurisdiction issues defined therein. Any holder of this document is advised that information contained herein reflects the Company's findings at the time of its intervention only and within the limits of Client's instructions, if any. The Company's sole responsibility is to its Client and this document does not exonerate parties to a transaction from exercising all their rights and obligations under the transaction documents. This document cannot be reproduced except in full, without prior written approval of the Company. Any unauthorized alteration, forgery or falsification of the content or appearance of this document is unlawful and offenders may be prosecuted to the fullest extent of the law. Unless otherwise stated the results shown in this test report refer only to the sample(s).

SGS Korea Co., Ltd. | 322, The C valley, 76, LS-ro, Dongen-gu, Anyang-si, Gyeonggi-do, Korea 431-080
t +82 (0)31 4008 000 f +82 (0)31 4008 059 <http://www.sgs.com/ko>

F401 Version2

Member of the SGS Group (Sociétés Généralistes de Surveillance)



Test Report No. F690101/LF-CTSAYAA15-37174

Issued Date : 2015. 07. 20

Page 7 of 7

Flow Chart for Halogen Test

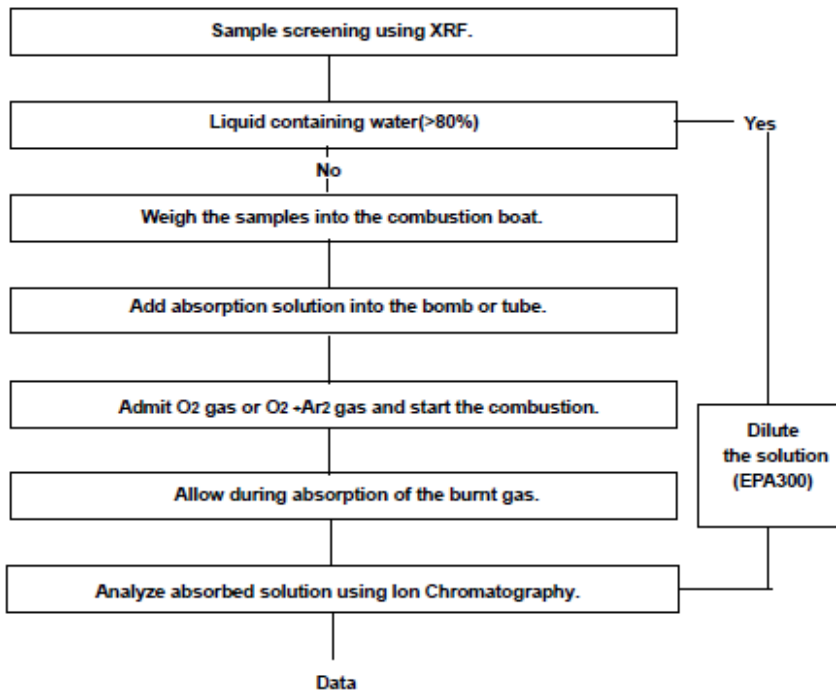

*** End of Report ***

This document is issued by the Company subject to its General Conditions of Service printed overleaf, available on request or accessible at <http://www.sgs.com/en/Terms-and-Conditions.aspx> and, for electronic format documents, subject to Terms and Conditions for Electronic Documents at www.sgs.com/terms_e-document.htm http://www.sgs.com/terms_e-document.htm. Attention is drawn to the limitation of liability, indemnification and jurisdiction issues defined therein. Any holder of this document is advised that information contained herein reflects the Company's findings at the time of its intervention only and within the limits of Client's instructions, if any. The Company's sole responsibility is to its Client and this document does not exonerate parties to a transaction from exercising all their rights and obligations under the transaction documents. This document cannot be reproduced except in full, without prior written approval of the Company. Any unauthorized alteration, forgery or falsification of the content or appearance of this document is unlawful and offenders may be prosecuted to the fullest extent of the law. Unless otherwise stated the results shown in this test report refer only to the sample(s).

F401 Version2

SGS Korea Co., Ltd.

322, The Ovalley, 76, LS-ro, Dongan-gu, Anyang-si, Gyeonggi-do, Korea 431-000
t +82 (0)31 4608 000 f +82 (0)31 4608 059 <http://www.sgskorea.com>

Member of the SGS Group (Société Générale de Surveillance)