



**PMS152**  
**8bit OTP Type SuLED IO Controller**  
***Datasheet***

***Version 0.02 – Jan. 24, 2018***

Copyright © 2018 by PADAUK Technology Co., Ltd., all rights reserved

6F-6, No.1, Sec. 3, Gongdao 5th Rd., Hsinchu City 30069, Taiwan, R.O.C.

TEL: 886-3-572-8688  [www.padauk.com.tw](http://www.padauk.com.tw)

### IMPORTANT NOTICE

PADAUK Technology reserves the right to make changes to its products or to terminate production of its products at any time without notice. Customers are strongly recommended to contact PADAUK Technology for the latest information and verify whether the information is correct and complete before placing orders.

PADAUK Technology products are not warranted to be suitable for use in life-support applications or other critical applications. PADAUK Technology assumes no liability for such applications. Critical applications include, but are not limited to, those which may involve potential risks of death, personal injury, fire or severe property damage.

PADAUK Technology assumes no responsibility for any issue caused by a customer's product design. Customers should design and verify their products within the ranges guaranteed by PADAUK Technology. In order to minimize the risks in customers' products, customers should design a product with adequate operating safeguards.

**PMS152 is NOT designed for AC RC step-down powered, high power ripple or high EFT requirement application. Please do NOT apply PMS152 to those application products.**

### Table of content

<b>1. Features</b> .....	<b>8</b>
1.1. Special Features .....	8
1.2. System Features .....	8
1.3. CPU Features .....	8
1.4. Package Information .....	8
<b>2. General Description and Block Diagram</b> .....	<b>9</b>
<b>3. Pin Definition and Functional Description</b> .....	<b>10</b>
<b>4. Device Characteristics</b> .....	<b>16</b>
4.1. AC/DC Device Characteristics .....	16
4.2. Absolute Maximum Ratings.....	17
4.3. Typical ILRC frequency vs. VDD .....	18
4.4. Typical IHRC frequency deviation vs. VDD .....	18
4.5. Typical ILRC Frequency vs. Temperature .....	19
4.6. Typical IHRC Frequency vs. Temperature (calibrated to 16MHz).....	19
4.7. Typical operating current vs. VDD @ system clock = ILRC/n .....	20
4.8. Typical operating current vs. VDD @ system clock = IHRC/n .....	20
4.9. Typical operating current vs. VDD @ system clock = 4MHz EOSC / n (reserved).....	21
4.10. Typical operating current vs. VDD @ system clock = 32KHz EOSC / n (reserved).....	21
4.11. Typical operating current vs. VDD @ system clock = 1MHz EOSC / n (reserved).....	22
4.12. Typical IO driving current ( $I_{OH}$ ) and sink current ( $I_{OL}$ ) .....	22
4.13. Typical IO input high/low threshold voltage ( $V_{IH}/V_{IL}$ ) .....	23
4.14. Typical resistance of IO pull high device .....	24
4.15. Typical power down current ( $I_{PD}$ ) and power save current ( $I_{PS}$ ).....	24
<b>5. Functional Description</b> .....	<b>26</b>
5.1. Program Memory - OTP .....	26
5.2. Boot Procedure .....	26
5.2.1. Timing charts for reset conditions.....	27
5.3. Data Memory - SRAM.....	28
5.4. Oscillator and Clock .....	28
5.4.1. Internal High RC oscillator and Internal Low RC oscillator .....	28
5.4.2. Chip calibration.....	29
5.4.3. IHRC Frequency Calibration and System Clock .....	29

5.4.4.	External Crystal Oscillator .....	30
5.4.5.	System Clock and LVR level .....	32
5.4.6.	System Clock Switching .....	33
5.5.	Comparator .....	34
5.5.1	Internal reference voltage ( $V_{\text{internal R}}$ ) .....	35
5.5.2	Using the comparator .....	37
5.5.3	Using the comparator and band-gap 1.20V .....	38
5.6	16-bit Timer (Timer16) .....	39
5.7	8-bit Timer (Timer2) with PWM generation .....	41
5.7.1	Using the Timer2 to generate periodical waveform .....	42
5.7.2	Using the Timer2 to generate 8-bit PWM waveform .....	44
5.7.3	Using the Timer2 to generate 6-bit PWM waveform .....	45
5.8	11-bit PWM Generators .....	46
5.8.1	PWM Waveform .....	46
5.8.2	Hardware Diagram .....	47
5.8.3	Equations for 11-bit PWM Generator .....	48
5.9	WatchDog Timer .....	49
5.10	Interrupt .....	50
5.11	Power-Save and Power-Down .....	52
5.11.1	Power-Save mode (“ <i>stopexe</i> ”) .....	52
5.11.2	Power-Down mode (“ <i>stopsys</i> ”) .....	53
5.11.3	Wake-up .....	53
5.12	IO Pins .....	55
5.13	Reset and LVR .....	56
5.13.1	Reset .....	56
5.13.2	LVR reset .....	56
<b>6.</b>	<b>IO Registers .....</b>	<b>57</b>
6.1.	ACC Status Flag Register ( <i>flag</i> ), IO address = 0x00 .....	57
6.2.	Stack Pointer Register ( <i>sp</i> ), IO address = 0x02 .....	57
6.3.	Clock Mode Register ( <i>clkmd</i> ), IO address = 0x03 .....	57
6.4.	Interrupt Enable Register ( <i>inten</i> ), IO address = 0x04 .....	58
6.5.	Interrupt Request Register ( <i>intrq</i> ), IO address = 0x05 .....	58
6.6.	Timer16 mode Register ( <i>t16m</i> ), IO address = 0x06 .....	59
6.7.	MISC Register ( <i>misc</i> ), IO address = 0x08 .....	59
6.8.	External Oscillator setting Register ( <i>eoscr</i> ), IO address = 0x0a .....	60
6.9.	Interrupt Edge Select Register ( <i>integs</i> ), IO address = 0x0c .....	60
6.10.	Port A Digital Input Enable Register ( <i>padier</i> ), IO address = 0x0d .....	60

6.11.	Port B Digital Input Enable Register ( <i>pbdier</i> ), IO address = 0x0e .....	61
6.12.	Port A Data Register ( <i>pa</i> ), IO address = 0x10 .....	61
6.13.	Port A Control Register ( <i>pac</i> ), IO address = 0x11 .....	61
6.14.	Port A Pull-High Register ( <i>paph</i> ), IO address = 0x12 .....	61
6.15.	Port B Data Register ( <i>pb</i> ), IO address = 0x14 .....	61
6.16.	Port B Control Register ( <i>pbc</i> ), IO address = 0x15 .....	61
6.17.	Port B Pull-High Register ( <i>pbph</i> ), IO address = 0x16 .....	61
6.18.	Comparator Control Register ( <i>gpcc</i> ), IO address = 0x18.....	62
6.19.	Comparator Selection Register ( <i>gpcs</i> ), IO address = 0x19.....	62
6.20.	Timer2 Control Register ( <i>tm2c</i> ), IO address = 0x1c .....	63
6.21.	Timer2 Scalar Register ( <i>tm2s</i> ), IO address = 0x17.....	63
6.22.	Timer2 Counter Register ( <i>tm2ct</i> ), IO address = 0x1d .....	64
6.23.	Timer2 Bound Register ( <i>tm2b</i> ), IO address = 0x09 .....	64
6.24.	PWMG0 control Register ( <i>pwmg0c</i> ), IO address = 0x20 .....	64
6.25.	PWMG Clock Register ( <i>pwmgclk</i> ), IO address = 0x21 .....	65
6.26.	PWMG0 Duty Value High Register ( <i>pwmg0dth</i> ), IO address = 0x22 .....	65
6.27.	PWMG0 Duty Value Low Register ( <i>pwmg0dtl</i> ), IO address = 0x23 .....	65
6.28.	PWMG Counter Upper Bound High Register ( <i>pwmgcubh</i> ), IO address = 0x24 .....	65
6.29.	PWMG Counter Upper Bound Low Register ( <i>pwmgcubl</i> ), IO address = 0x25 .....	65
6.30.	PWMG1 control Register ( <i>pwmg1c</i> ), IO address = 0x26 .....	66
6.31.	PWMG1 Duty Value High Register ( <i>pwmg1dth</i> ), IO address = 0x28 .....	66
6.32.	PWMG1 Duty Value Low Register ( <i>pwmg1dtl</i> ), IO address = 0x29 .....	66
6.33.	PWMG2 control Register ( <i>pwmg2c</i> ), IO address = 0x2C.....	67
6.34.	PWMG2 Duty Value High Register ( <i>pwmg2dth</i> ), IO address = 0x2E .....	67
6.35.	PWMG2 Duty Value Low Register ( <i>pwmg2dtl</i> ), IO address = 0x2F .....	67
<b>7.</b>	<b>Instructions .....</b>	<b>68</b>
7.1.	Data Transfer Instructions .....	69
7.2.	Arithmetic Operation Instructions .....	72
7.3.	Shift Operation Instructions .....	74
7.4.	Logic Operation Instructions.....	75
7.5.	Bit Operation Instructions .....	78
7.6.	Conditional Operation Instructions .....	79
7.7.	System control Instructions .....	80
7.8.	Summary of Instructions Execution Cycle .....	82
7.9.	Summary of affected flags by Instructions.....	82
<b>8.</b>	<b>Code Options .....</b>	<b>83</b>
<b>9.</b>	<b>Special Notes .....</b>	<b>84</b>

9.1.	Warning .....	84
9.2.	Using IC .....	84
9.2.1.	IO pin usage and setting .....	84
9.2.2.	Interrupt .....	85
9.2.3.	System clock switching .....	85
9.2.4.	Watchdog .....	85
9.2.5.	TIMER time out .....	85
9.2.6.	IHRC .....	86
9.2.7.	LVR .....	86
9.2.8.	Instructions .....	86
9.2.9.	BIT definition .....	86
9.2.10.	Programming Writing .....	86
9.3.	Using ICE .....	87

**Revision History:**

Revision	Date	Description
0.01	2017/07/21	1 <sup>st</sup> version
0.02	2018/01/24	<ol style="list-style-type: none"> <li>1. Amend the address and phone number of PADAUK Technology Co.,Ltd.</li> <li>2. Amend Section 1.3 CPU Features</li> <li>3. Amend Section 4.1 AC/DC Device Characteristics</li> <li>4. Amend Section 4.3 Typical ILRC frequency vs. VDD</li> <li>5. Amend Section 4.4 Typical IHRC frequency deviation vs. VDD</li> <li>6. Amend Section 4.5 Typical ILRC Frequency vs. Temperature</li> <li>7. Amend Section 4.6 Typical IHRC Frequency vs. Temperature</li> <li>8. Amend Section 4.7 Typical operating current vs. VDD @ system clock = ILRC/n</li> <li>9. Amend Section 4.8 Typical operating current vs. VDD @ system clock = IHRC/n</li> <li>10. Amend Section 4.9 Typical operating current vs. VDD @ system clock = 4MHz EOSC / n</li> <li>11. Amend Section 4.10 Typical operating current vs. VDD @ system clock = 32KHz EOSC / n</li> <li>12. Amend Section 4.11 Typical operating current vs. VDD @ system clock = 1MHz EOSC / n</li> <li>13. Amend Section 4.13 Typical IO input high/low threshold voltage (VIH/VIL)</li> <li>14. Amend Section 4.15 Typical power down current and power save current</li> <li>15. Delete Section 4.16 Timing charts for boot up conditions</li> <li>16. Amend Section 5.1. Program Memory – OTP</li> <li>17. Add Section 5.2.1 Timing charts for reset conditions</li> <li>18. Amend Table 2: Three oscillation circuits</li> <li>19. Amend Section 5.4.3. IHRC Frequency Calibration and System Clock</li> <li>20. Amend Section 5.4.4. External Crystal Oscillator</li> <li>21. Amend Section 5.4.5. System Clock and LVR level</li> <li>22. Amend Fig.3: Options of System Clock</li> <li>23. Amend Section 5.5.2. Using the comparator</li> <li>24. Amend Section 5.5.3 Using the comparator and band-gap 1.20V</li> <li>25. Amend Section 5.10 Interrupt</li> <li>26. Amend Section 5.11.1 Power-Save mode</li> <li>27. Amend Section 5.11.2 Power-Down mode</li> <li>28. Amend Section 5.11.3 Wake-up</li> <li>29. Amend Section 6.3. Clock Mode Register</li> <li>30. Amend Section 6.7 MISC Register</li> <li>31. Amend Section 6.10. Port A Digital Input Enable Register</li> <li>32. Amend Section 6.11. Port B Digital Input Enable Register</li> <li>33. Delete Section 6.13. MISC2 Register</li> <li>34. Amend Section 6.14. Port A Pull-High Register</li> <li>35. Amend Section 6.19. Comparator Selection Register.</li> <li>36. Amend Section 6.20. Timer2 Control Register</li> <li>37. Amend Section 6.21. Timer2 Scalar Register</li> <li>38. Delete the Symbol “pc0” in Chapter 7</li> <li>39. Amend Chapter 8 Code Options</li> <li>40. Amend Section 9.2.1. IO pin usage and setting</li> <li>41. Amend Section 9.2.7 LVR</li> <li>42. Amend Section 9.2.9 BIT definition</li> <li>43. Amend Section 9.2.10. Programming Writing</li> <li>44. Amend Section 9.3. Using ICE</li> </ol>

### 1. Features

#### 1.1. Special Features

- ◆ General purpose series
- ◆ Please don't apply to AC RC step-down powered, high power ripple or high EFT requirement application
- ◆ Operating temperature range: -20°C ~ 70°C

#### 1.2. System Features

- ◆ 1.25KW OTP program memory
- ◆ 80 Bytes data RAM
- ◆ One hardware 16-bit timer
- ◆ One hardware 8-bit timers with 6/7/8-bit PWM generation
- ◆ One set triple 11bit SuLED (Super LED) PWM generators and timers
- ◆ One hardware comparator
- ◆ 14 IO pins with optional pull-high resistor
- ◆ Three different IO Driving capability group to meet different application requirements
  - (1) PB3, PB5, PB7 Drive/ Sink Current= 5mA/30mA
  - (2) Other IOs (except PA5) Drive/ Sink Current = 5mA/10mA
  - (3) PA5 Sink Current = 10mA
- ◆ Every IO pin can be configured to enable wake-up function
- ◆ Clock sources: IHRC, ILRC & EOSC(XTAL mode, Reserved<sup>1</sup>)
- ◆ For every wake-up enabled IO, two optional wake-up speed are supported: normal and fast
- ◆ Eight levels of LVR: 4.5V, 3.5V, 3.0V, 2.75V, 2.5V, 2.2V, 2.0V and 1.8V
- ◆ Two selectable external interrupt pins: PA0/PB5, PB0/PA4
- ◆ Band-gap circuit to provide 1.20V reference voltage

#### 1.3. CPU Features

- ◆ One processing unit operating mode
- ◆ 86 powerful instructions
- ◆ Most instructions are 1T execution cycle
- ◆ Programmable stack pointer to provide adjustable stack level
- ◆ Direct and indirect addressing modes for data access. Data memories are available for use as an index pointer of Indirect addressing mode
- ◆ IO space and memory space are independent

#### 1.4. Package Information

- ◆ PMS152-S16: SOP16 (150mil)
- ◆ PMS152-1J16A: QFN3\*3-16pin (0.5mm pitch)
- ◆ PMS152-S14: SOP14 (150mil)
- ◆ PMS152-M10: MSOP10 (118mil)
- ◆ PMS152-S08: SOP8 (150mil)
- ◆ PMS152-U06: SOT23-6 (60mil)

---

<sup>1</sup> Please contact our sales representative.



### 2. General Description and Block Diagram

The PMS152 family is an IO-Type, fully static, OTP-based CMOS 8-bit microcontroller. It employs RISC architecture and all the instructions are executed in one cycle except that some instructions are two cycles that handle indirect memory access.

1.25KW bits OTP program memory and 80 bytes data SRAM are inside, one hardware comparator is built inside the chip to compare signal between two pin or with either internal reference voltage  $V_{\text{internalR}}$  or internal band-gap reference voltage. PMS152 also provides three hardware timers: one 16-bit timer, one 8-bit timer with PWM generation, and one new triple 11-bit timer with SuLED PWM generation (PWMG0, PWMG1 & PWMG2) are included.

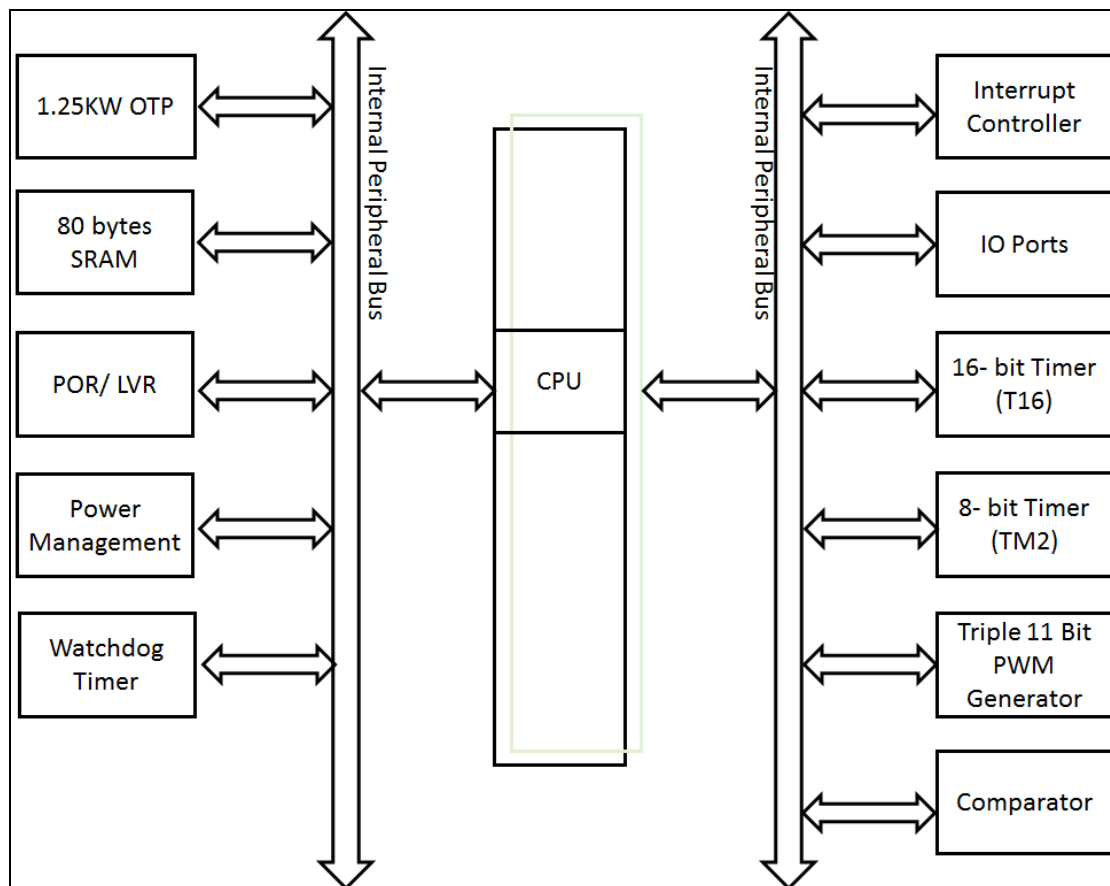

### 3. Pin Definition and Functional Description

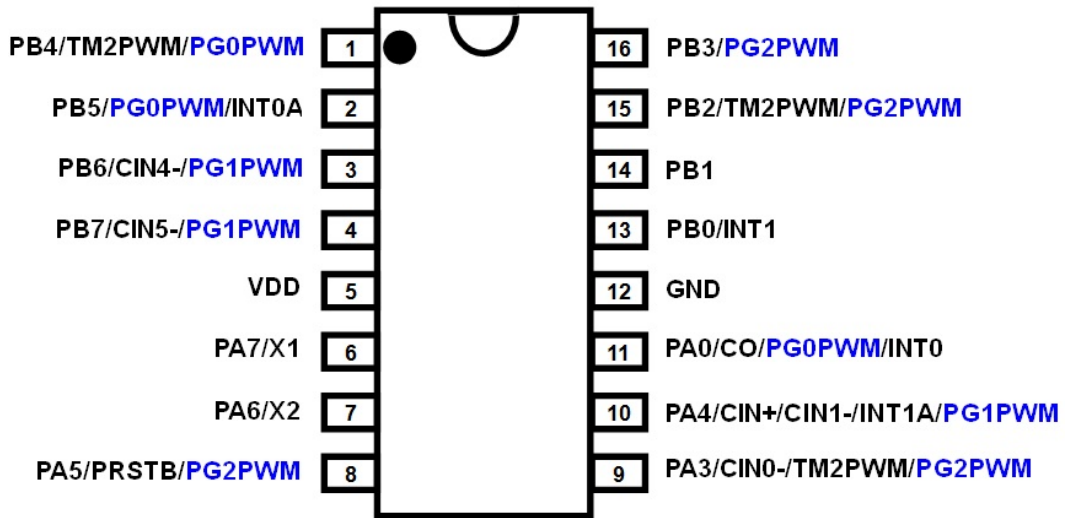

PMS152-S16 (SOP16-150mil)

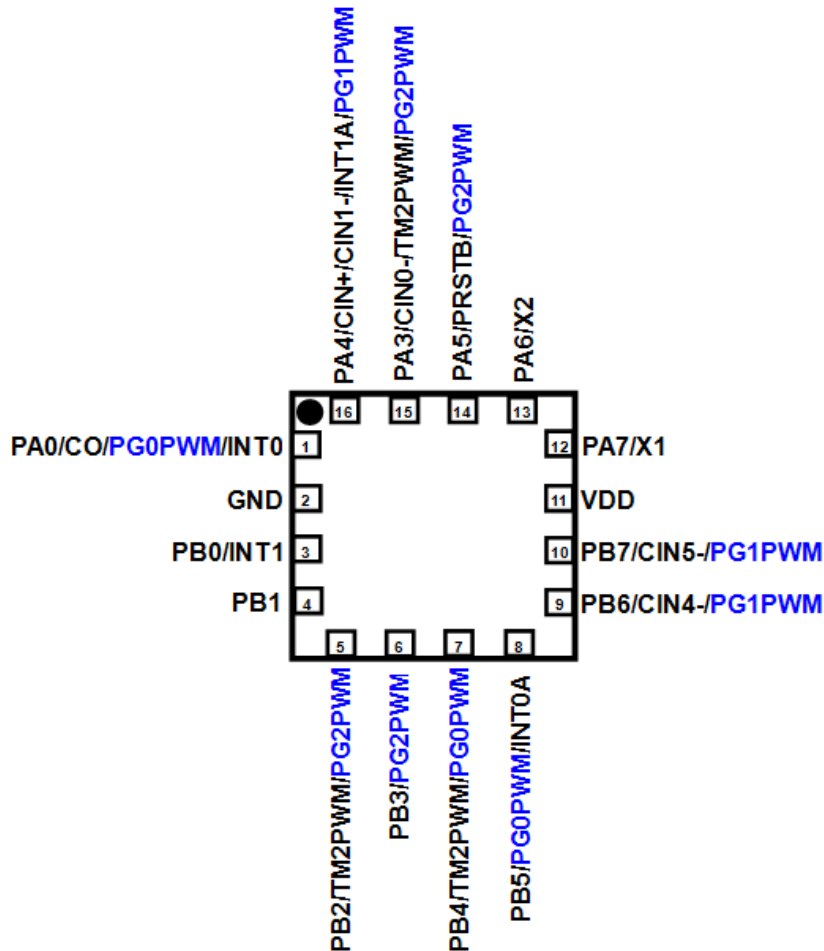

PMS152-1J16A (QFN3\*3-16P-0.5pitch)

# PMS152

## 8bit OTP Type SuLED IO Controller

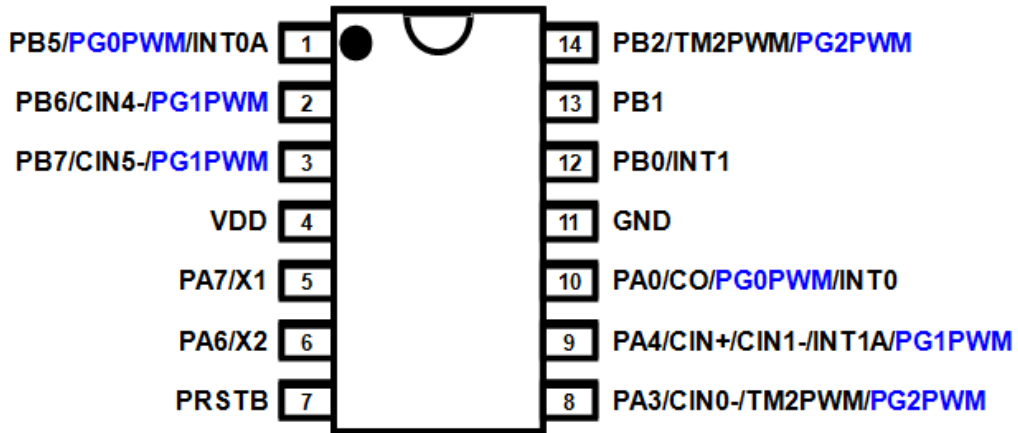

PMS152-S14 (SOP14-150mil)

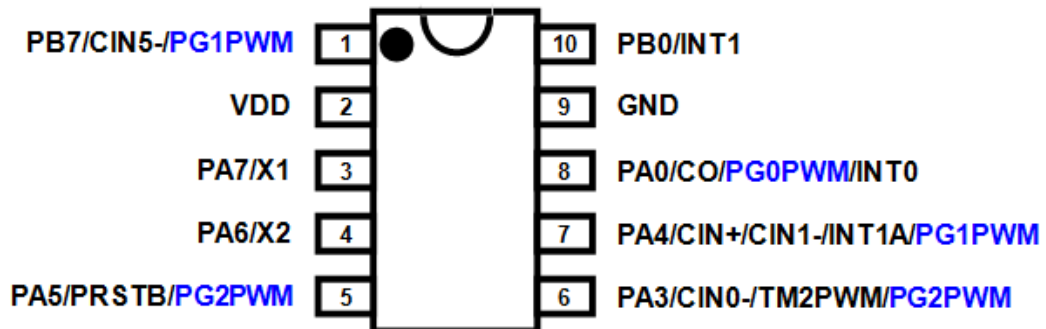

PMS152-M10 (MSOP10-118mil)

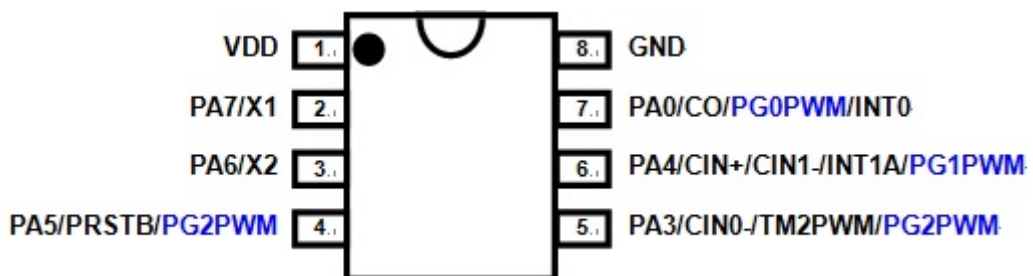

PMS152-S08 (SOP8-150mil)

# PMS152

## 8bit OTP Type SuLED IO Controller

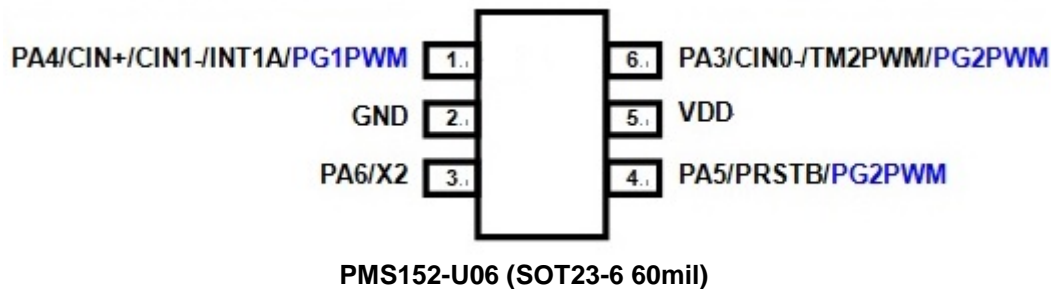

Pin Name	Pin Type & Buffer Type	Description
PA7 / X1	IO ST / CMOS	The functions of this pin can be: (1) Bit 7 of port A. It can be configured as input or output with pull-up resistor. (2) X1 is Crystal XIN when crystal oscillator is used. If this pin is used for crystal oscillator, bit 7 of <b>padier</b> register must be programmed "0" to avoid leakage current. This pin can be used to wake-up system during sleep mode; however, wake-up function is also disabled if bit 7 of <b>padier</b> register is "0".
PA6 / X2	IO ST / CMOS	The functions of this pin can be: (1) Bit 6 of port A. It can be configured as input or output with pull-up resistor. (2) X2 is Crystal XOUT when crystal oscillator is used. If this pin is used for crystal oscillator, bit 6 of <b>padier</b> register must be programmed "0" to avoid leakage current. This pin can be used to wake-up system during sleep mode; however, wake-up function is also disabled if bit 6 of <b>padier</b> register is "0".
PA5 / PRSTB / PG2PWM	IO (OD) ST / CMOS	The functions of this pin can be: (1) Bit 5 of port A. It can be configured as input or open-drain output pin. (2) Hardware reset. (3) Output of 11-bit PWM generator PWMG2. This pin can be used to wake-up system during sleep mode; however, wake-up function is also disabled if bit 5 of <b>padier</b> register is "0". <u>Please put 33Ω resistor in series to have high noise immunity when this pin is in input mode.</u>
PA4 / CIN+ / CIN1- / INT1A / PG1PWM	IO ST / CMOS / Analog	The functions of this pin can be: (1) Bit 4 of port A. It can be configured as digital input, two-state output with pull-up resistor by software independently (2) Plus input source of comparator. (3) Minus input source 1 of comparator. (4) External interrupt line 1A. It can be used as an external interrupt line 1. <u>Both rising edge and falling edge are accepted to request interrupt service and configurable by register setting</u> (5) Output of 11-bit PWM generator PWMG1. When this pin is configured as analog input, please use bit 4 of register <b>padier</b> to disable the digital input to prevent current leakage. The bit 4 of <b>padier</b> register can be set to "0" to disable digital input; wake-up from power-down by toggling this pin is also disabled.

# PMS152

## 8bit OTP Type SuLED IO Controller

Pin Name	Pin Type & Buffer Type	Description
PA3 / CIN0- / TM2PWM / PG2PWM	IO ST / CMOS / Analog	<p>The functions of this pin can be:</p> <ol style="list-style-type: none"> <li>(1) Bit 3 of port A. It can be configured as digital input, two-state output with pull-up resistor independently by software</li> <li>(2) Minus input source 0 of comparator.</li> <li>(3) PWM output from Timer2</li> <li>(4) Output of 11-bit PWM generator PWMG02</li> </ol> <p>When this pin is configured as analog input, please use bit 3 of register <b>padier</b> to disable the digital input to prevent current leakage. The bit 3 of <b>padier</b> register can be set to “0” to disable digital input; wake-up from power-down by toggling this pin is also disabled.</p>
PA0 / CO / PG0PWM / INT0	IO ST / CMOS	<p>The functions of this pin can be:</p> <ol style="list-style-type: none"> <li>(1) Bit 0 of port A. It can be configured as digital input, two-state output with pull-up resistor independently by software</li> <li>(2) Output of comparator.</li> <li>(3) Output of 11-bit PWM generator PWMG0.</li> <li>(4) External interrupt line 0. It can be used as an external interrupt line 0. <u>Both rising edge and falling edge are accepted to request interrupt service and configurable by register setting</u></li> </ol> <p>The bit 0 of <b>padier</b> register can be set to “0” to disable wake-up from power-down by toggling this pin.</p>
PB7 / CIN5- / PG1PWM	IO ST / CMOS / Analog	<p>The functions of this pin can be:</p> <ol style="list-style-type: none"> <li>(1) Bit 7 of port B. It can be configured as digital input, two-state output with pull-up resistor independently by software</li> <li>(2) Minus input source 5 of comparator.</li> <li>(3) Output of 11-bit PWM generator PWMG1.</li> </ol> <p>When this pin is configured as analog input, please use bit 7 of register <b>pbdier</b> to disable the digital input to prevent current leakage. The bit 7 of <b>pbdier</b> register can be set to “0” to disable digital input; wake-up from power-down by toggling this pin is also disabled.</p>
PB6 / CIN4- / PG1PWM	IO ST / CMOS / Analog	<p>The functions of this pin can be:</p> <ol style="list-style-type: none"> <li>(1) Bit 6 of port B. It can be configured as digital input, two-state output with pull-up resistor independently by software</li> <li>(2) Minus input source 4 of comparator.</li> <li>(3) Output of 11-bit PWM generator PWMG1.</li> </ol> <p>When this pin is configured as analog input, please use bit 6 of register <b>pbdier</b> to disable the digital input to prevent current leakage. The bit 6 of <b>pbdier</b> register can be set to “0” to disable digital input; wake-up from power-down by toggling this pin is also disabled.</p>

# PMS152

## 8bit OTP Type SuLED IO Controller

Pin Name	Pin Type & Buffer Type	Description
PB5 / PG0PWM / INT0A	IO ST / CMOS	<p>The functions of this pin can be:</p> <ol style="list-style-type: none"> <li>(1) Bit 5 of port B. It can be configured as digital input, two-state output with pull-up resistor independently by software</li> <li>(2) Output of 11-bit PWM generator PWMG0.</li> <li>(3) External interrupt line 0A. It can be used as an external interrupt line 0. <u>Both rising edge and falling edge are accepted to request interrupt service and configurable by register setting.</u></li> </ol> <p>The bit 5 of <b><i>pbdier</i></b> register can be set to “0” to disable digital input; wake-up from power-down by toggling this pin is also disabled.</p>
PB4 / TM2PWM / PG0PWM	IO ST / CMOS	<p>The functions of this pin can be:</p> <ol style="list-style-type: none"> <li>(1) Bit 4 of port B. It can be configured as digital input, two-state output with pull-up resistor independently by software</li> <li>(2) PWM output from Timer2</li> <li>(3) Output of 11-bit PWM generator PWMG0.</li> </ol> <p>The bit 4 of <b><i>pbdier</i></b> register can be set to “0” to disable digital input; wake-up from power-down by toggling this pin is also disabled.</p>
PB3 / PG2PWM	IO ST / CMOS	<p>The functions of this pin can be:</p> <ol style="list-style-type: none"> <li>(1) Bit 3 of port B. It can be configured as digital input, two-state output with pull-up resistor independently by software</li> <li>(2) Output of 11-bit PWM generator PWMG2</li> </ol> <p>The bit 3 of <b><i>pbdier</i></b> register can be set to “0” to disable digital input; wake-up from power-down by toggling this pin is also disabled.</p>
PB2 / TM2PWM / PG2PWM	IO ST / CMOS	<p>The functions of this pin can be:</p> <ol style="list-style-type: none"> <li>(1) Bit 2 of port B. It can be configured as digital input, two-state output with pull-up resistor independently by software</li> <li>(2) PWM output from Timer2</li> <li>(3) Output of 11-bit PWM generator PWMG2</li> </ol> <p>The bit 2 of <b><i>pbdier</i></b> register can be set to “0” to disable digital input; wake-up from power-down by toggling this pin is also disabled.</p>
PB1	IO ST / CMOS	<p>The functions of this pin can be:</p> <p>Bit 1 of port B. It can be configured as digital input, two-state output with pull-up resistor independently by software.</p> <p>The bit 1 of <b><i>pbdier</i></b> register can be set to “0” to disable digital input; wake-up from power-down by toggling this pin is also disabled.</p>

# PMS152

## 8bit OTP Type SuLED IO Controller

Pin Name	Pin Type & Buffer Type	Description
PB0 / INT1	IO ST / CMOS	<p>The functions of this pin can be:</p> <p>(1) Bit 0 of port B. It can be configured as digital input, and two-state output mode with pull-up resistor independently by software.</p> <p>(2) External interrupt line 1. It can be used as an external interrupt line 1. Both rising edge and falling edge are accepted to request interrupt service and configurable by register setting.</p> <p>If bit 0 of <b><i>pbdir</i></b> register is set to “0” to disable digital input, wake-up from power-down by toggling this pin is also disabled.</p>
VDD	VDD	Positive power
GND	GND	Ground
<p><b>Notes:</b> <b>IO:</b> Input/Output; <b>ST:</b> Schmitt Trigger input; <b>OD:</b> Open Drain; <b>Analog:</b> Analog input pin  <b>CMOS:</b> CMOS voltage level</p>		

### 4. Device Characteristics

#### 4.1. AC/DC Device Characteristics

All data are acquired under the conditions of  $T_a = -20^{\circ}\text{C} \sim 75^{\circ}\text{C}$ ,  $V_{DD} = 5.0\text{V}$ ,  $f_{SYS} = 2\text{MHz}$  unless noted.

Symbol	Description	Min	Typ	Max	Unit	Conditions ( $T_a = 25^{\circ}\text{C}$ )
$V_{DD}$	Operating Voltage	1.8*	5.0	5.5	V	* Subject to LVR tolerance
LVR%	Low Voltage Reset Tolerance	-5		5	%	
$f_{SYS}$	System clock (CLK)* =					
	IHRC/2	0		8M	Hz	$V_{DD} \geq 3.5\text{V}$
	IHRC/4	0		4M		$V_{DD} \geq 2.5\text{V}$
	IHRC/8	0		2M		$V_{DD} \geq 1.8\text{V}$
ILRC		55K		$V_{DD} = 3.0\text{V}$		
$V_{POR}$	Power On Reset Voltage		1.8*		V	* Subject to LVR tolerance
$I_{OP}$	Operating Current		1		mA	$f_{SYS} = \text{IHRC}/16 = 1\text{MIPS}@5.0\text{V}$
			15		$\mu\text{A}$	$f_{SYS} = \text{ILRC} = 55\text{KHz}@3.3\text{V}$
$I_{PD}$	Power Down Current (by <b>stopsys</b> command)		1		$\mu\text{A}$	$f_{SYS} = 0\text{Hz}$ , $V_{DD} = 5.0\text{V}$
			0.6		$\mu\text{A}$	$f_{SYS} = 0\text{Hz}$ , $V_{DD} = 3.3\text{V}$
$I_{PS}$	Power Save Current (by <b>stopexe</b> command)		5		$\mu\text{A}$	$V_{DD} = 5.0\text{V}$ ; $f_{SYS} = \text{ILRC}$ Only ILRC module is enabled.
$V_{IL}$	Input low voltage for IO lines	0		$0.1 V_{DD}$	V	PA5
		0		$0.2 V_{DD}$		Others IO
$V_{IH}$	Input high voltage for IO lines	$0.8 V_{DD}$		$V_{DD}$	V	PA5
		$0.7 V_{DD}$		$V_{DD}$		Others IO
$I_{OL}$	IO lines sink current					
	PA7, PA6, PA5, PA4, PA3, PA0		10		mA	$V_{DD} = 5.0\text{V}$ , $V_{OL} = 0.5\text{V}$
	PB6, PB4, PB2, PB1, PB0		10			
	PB7, PB5, PB3		30			
$I_{OH}$	IO lines drive current					
	PA5		0		mA	$V_{DD} = 5.0\text{V}$ , $V_{OH} = 4.5\text{V}$
	PA7, PA6, PA4, PA3, PA0		-5			
	PB7, PB6, PB5, PB4, PB3		-5			
PB2, PB1, PB0		-5				
$V_{IN}$	Input voltage	-0.3		$V_{DD} + 0.3$	V	
$I_{INJ(PIN)}$	Injected current on pin			1	mA	$V_{DD} + 0.3 \geq V_{IN} \geq -0.3$
$R_{PH}$	Pull-high Resistance		100		K $\Omega$	$V_{DD} = 5.0\text{V}$
			200			$V_{DD} = 3.0\text{V}$
$V_{BG}$	Band-gap Reference Voltage	1.145*	1.20*	1.255*	V	$V_{DD} = 2.2\text{V} \sim 5.5\text{V}$ $-20^{\circ}\text{C} < T_a < 70^{\circ}\text{C}^*$
$f_{IHRC}$	Frequency of IHRC after calibration *	15.76*	16*	16.24*	MHz	$25^{\circ}\text{C}$ , $V_{DD} = 2.2\text{V} \sim 5.5\text{V}$
		15.20*	16*	16.80*		$V_{DD} = 2.2\text{V} \sim 5.5\text{V}$ , $-20^{\circ}\text{C} < T_a < 70^{\circ}\text{C}^*$
		13.60*	16*	18.40*		$V_{DD} = 1.8\text{V} \sim 5.5\text{V}$ , $-20^{\circ}\text{C} < T_a < 70^{\circ}\text{C}$
$t_{INT}$	Interrupt pulse width	30			ns	$V_{DD} = 5.0\text{V}$



Symbol	Description	Min	Typ	Max	Unit	Conditions (Ta=25°C)
V <sub>DR</sub>	RAM data retention voltage*	1.5			V	in stop mode
t <sub>WDT</sub>	Watchdog timeout period		8k		T <sub>ILRC</sub>	misc[1:0]=00 (default)
			16k			misc[1:0]=01
			64k			misc[1:0]=10
			256k			misc[1:0]=11
t <sub>WUP</sub>	Wake-up time period for fast wake-up		45		T <sub>ILRC</sub>	Where T <sub>ILRC</sub> is the time period of ILRC
	Wake-up time period for normal wake-up		3000			
t <sub>SBP</sub>	System boot-up period from power-on for Normal boot-up		55		ms	V <sub>DD</sub> =5V
	System boot-up period from power-on for Fast boot-up		820		us	
t <sub>RST</sub>	External reset pulse width	120			us	@ V <sub>DD</sub> =5V
CP <sub>os</sub>	Comparator offset*		±10	±20	mV	
CP <sub>cm</sub>	Comparator input common mode*	0		V <sub>DD</sub> -1.5	V	
CP <sub>spt</sub>	Comparator response time**		100	500	ns	Both Rising and Falling
CP <sub>mc</sub>	Stable time to change comparator mode		2.5	7.5	us	
CP <sub>cs</sub>	Comparator current consumption		20		uA	V <sub>DD</sub> = 3.3V

\*These parameters are for design reference, not tested for each chip.

### 4.2. Absolute Maximum Ratings

- Supply Voltage ..... 1.8V ~ 5.5V (Maximum Rating: 5.5V)  
\*If V<sub>DD</sub> is over the maximum rating, it may lead to a permanent damage of IC.
- Input Voltage ..... -0.3V ~ V<sub>DD</sub> + 0.3V
- Operating Temperature ..... -20°C ~ 70°C
- Storage Temperature ..... -50°C ~ 125°C
- Junction Temperature ..... 150°C

### 4.3. Typical ILRC frequency vs. VDD

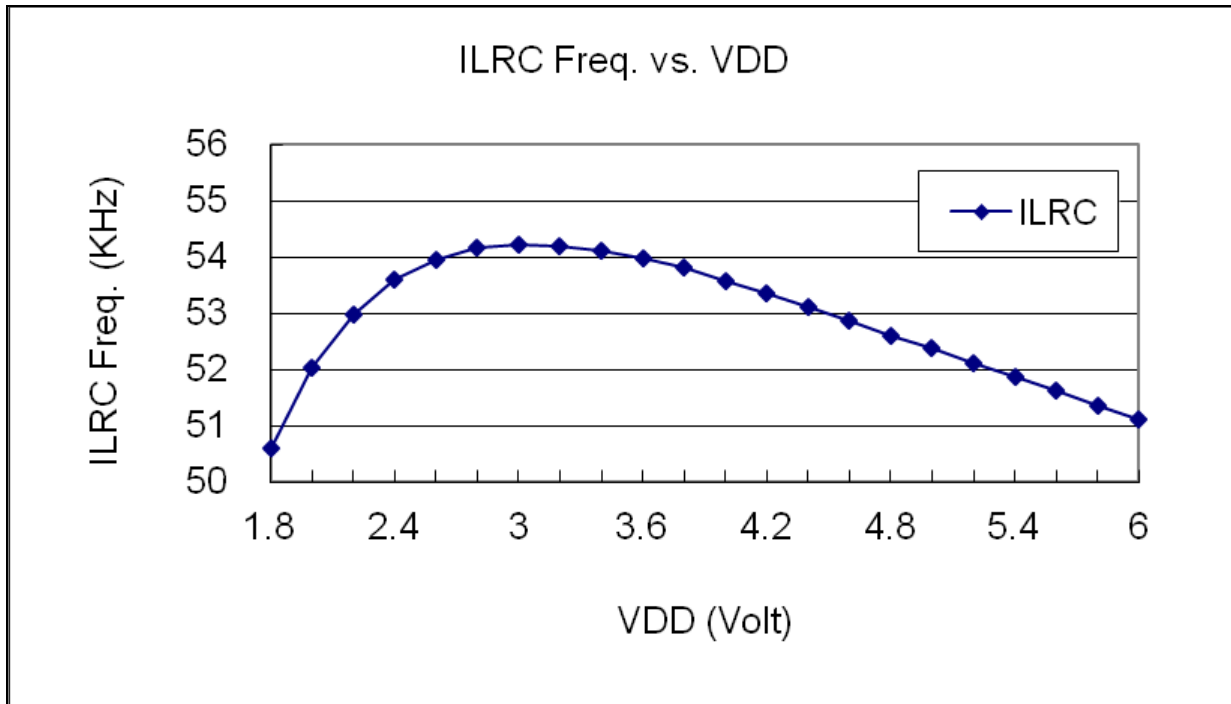

### 4.4. Typical IHRC frequency deviation vs. VDD

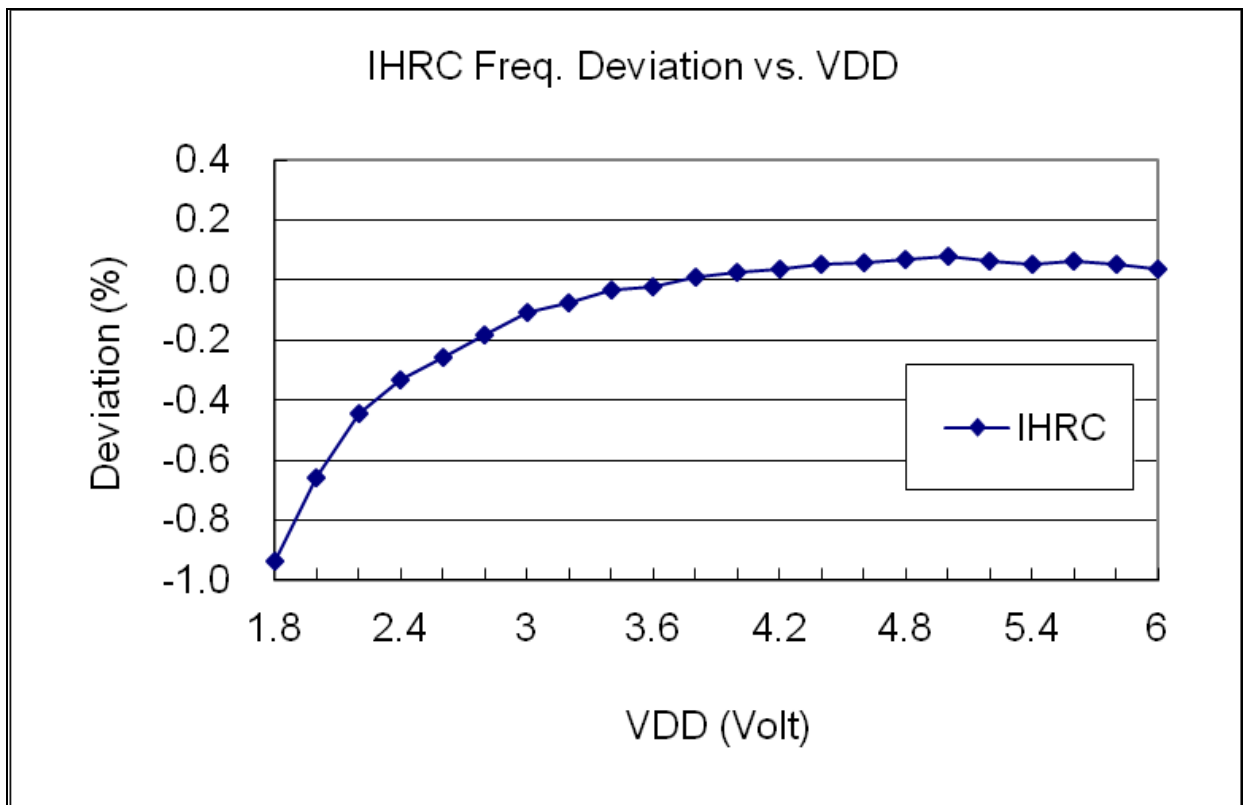

Note: IHRC is calibrated to 16MHz

### 4.5. Typical ILRC Frequency vs. Temperature

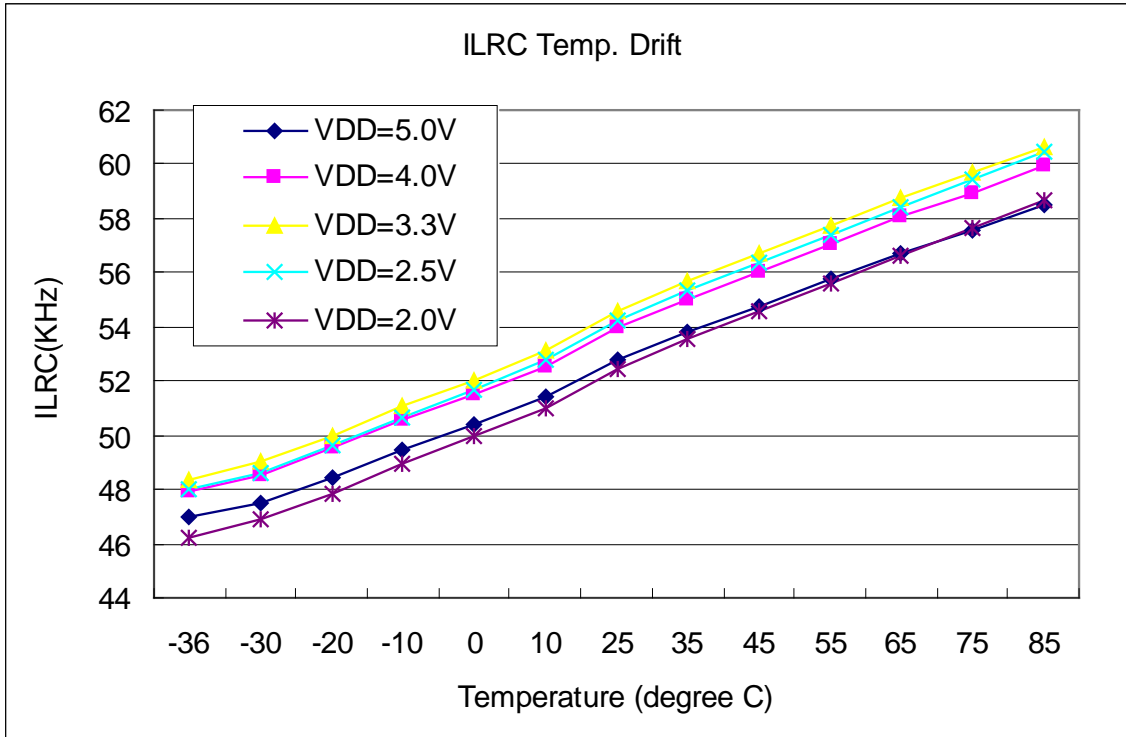

### 4.6. Typical IHRC Frequency vs. Temperature (calibrated to 16MHz)

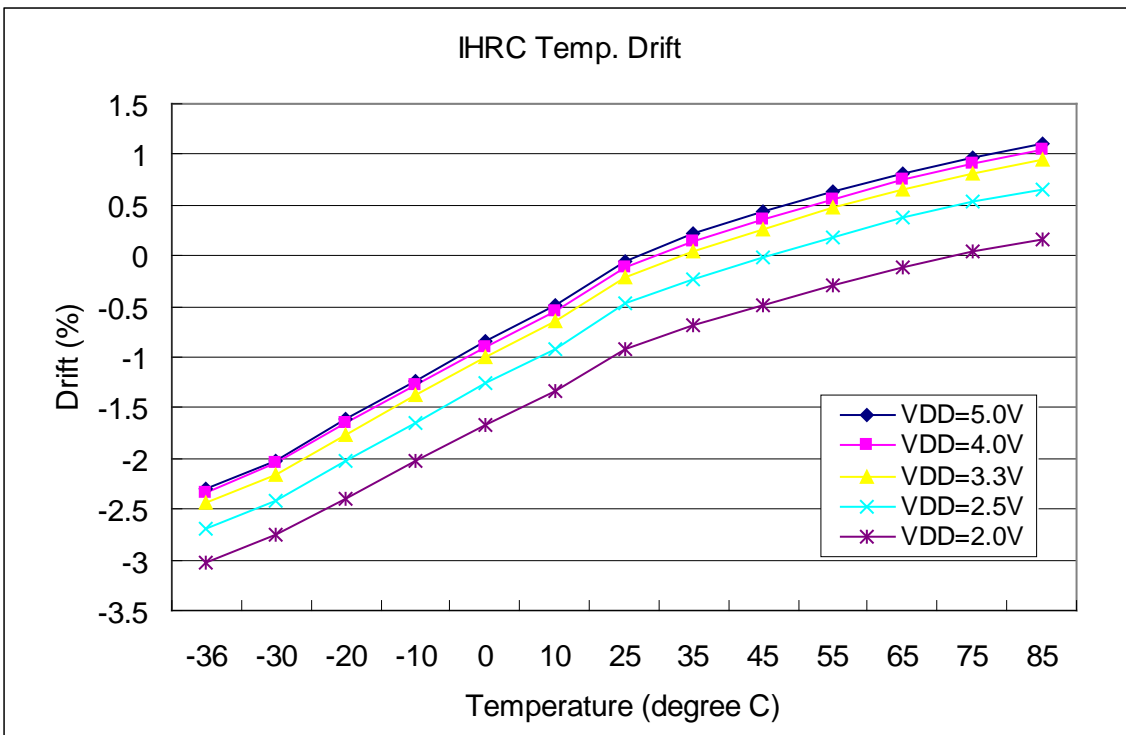

### 4.7. Typical operating current vs. VDD @ system clock = ILRC/n

Conditions:

**ON:** Band-gap, LVR, ILRC; **OFF:** IHRC, EOSC, T16, TM2;

**IO:** PA0:0.5Hz output toggle and no loading, **others:** input and no floating

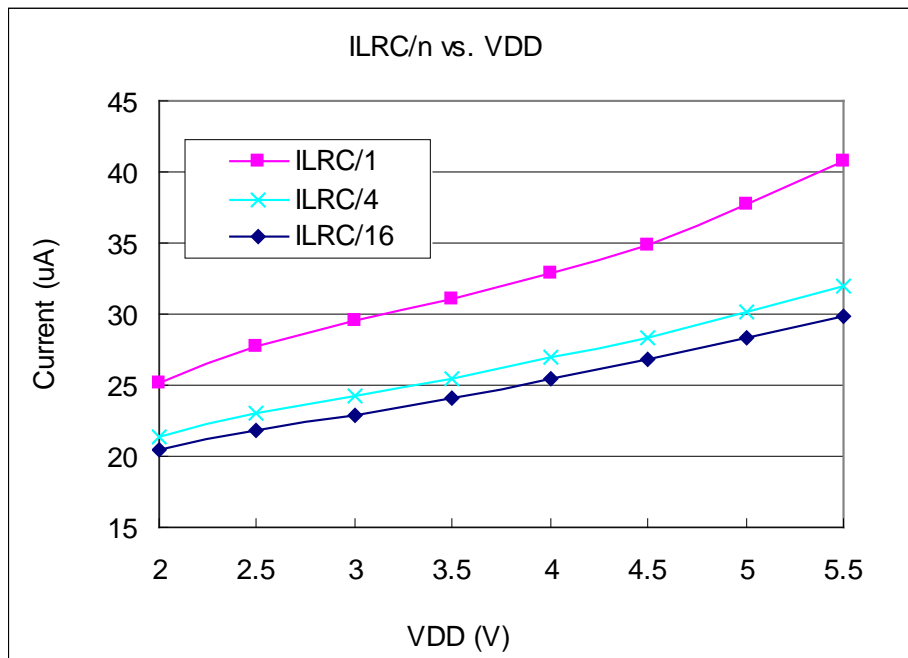

### 4.8. Typical operating current vs. VDD @ system clock = IHRC/n

Conditions:

**ON:** Band-gap, LVR, IHRC; **OFF:** ILRC, EOSC, T16, TM2;

**IO:** PA0:0.5Hz output toggle and no loading, **others:** input and no floating

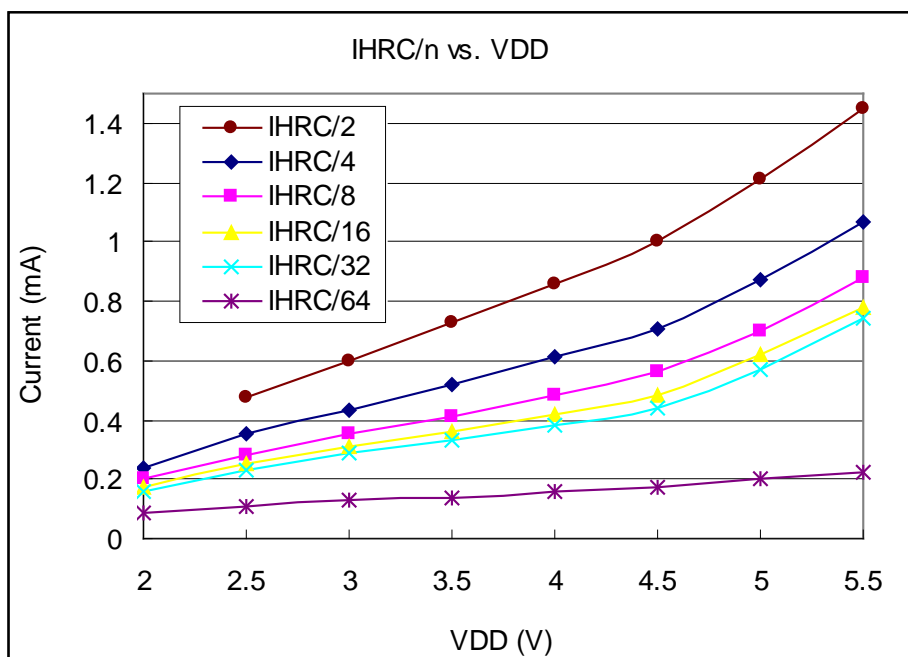

### 4.9. Typical operating current vs. VDD @ system clock = 4MHz EOSC / n (reserved)

Conditions:

**ON:** Band-gap, LVR , EOSC; **OFF:** IHRC, ILRC, T16, TM2;

**IO:** PA0:0.5Hz output toggle and no loading, **others:** input and no floating

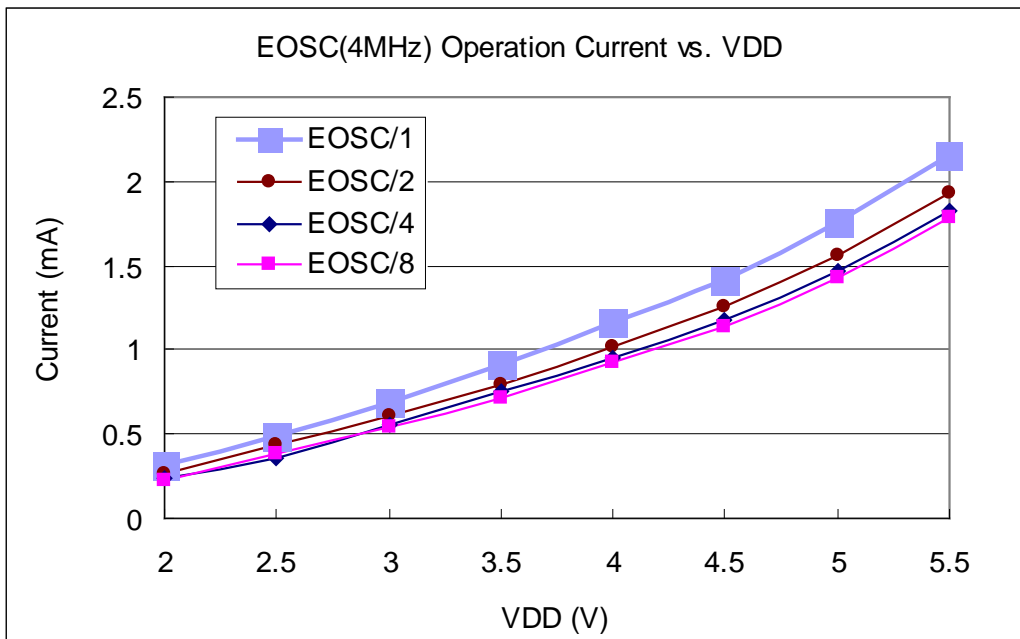

### 4.10. Typical operating current vs. VDD @ system clock = 32KHz EOSC / n (reserved)

Conditions:

**ON:** Band-gap, LVR, EOSC; **OFF:** IHRC, ILRC, T16, TM2;

**IO:** PA0:0.5Hz output toggle and no loading, **others:** input and no floating

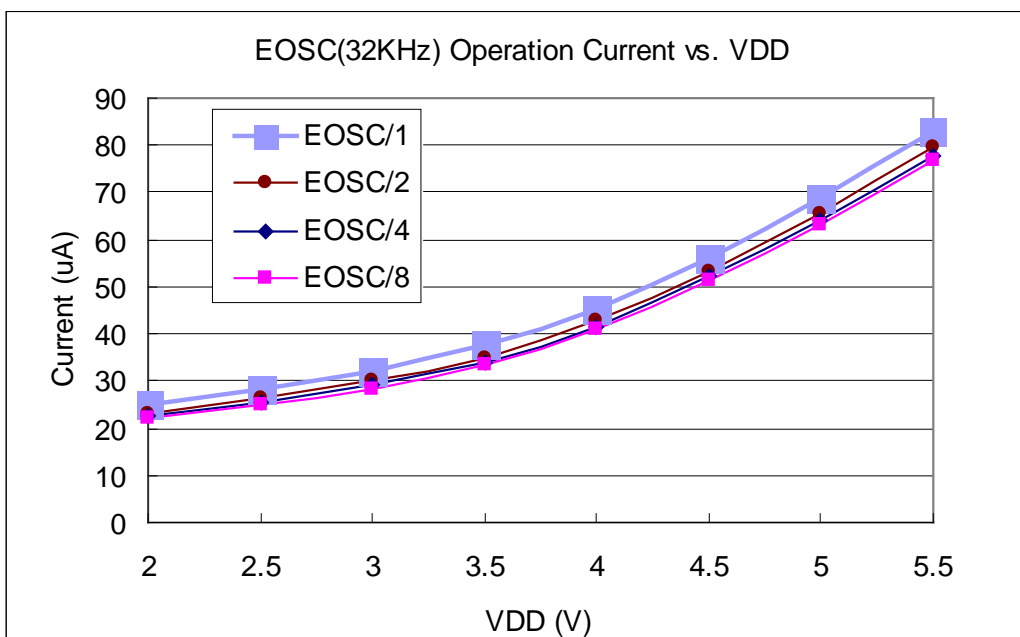

### 4.11. Typical operating current vs. VDD @ system clock = 1MHz EOSC / n (reserved)

Conditions:

**ON:** Band-gap, LVR, EOSC; **OFF:** IHRC, ILRC, T16, TM2;

**IO:** PA0:0.5Hz output toggle and no loading, **others:** input and no floating

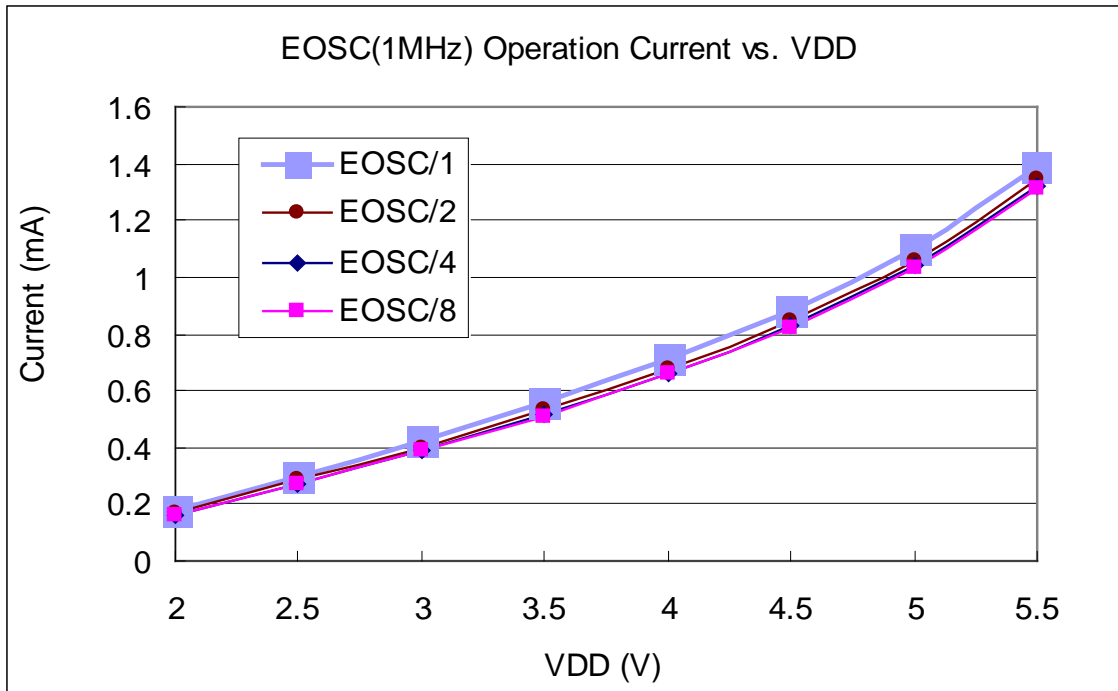

### 4.12. Typical IO driving current (I<sub>OH</sub>) and sink current (I<sub>OL</sub>)

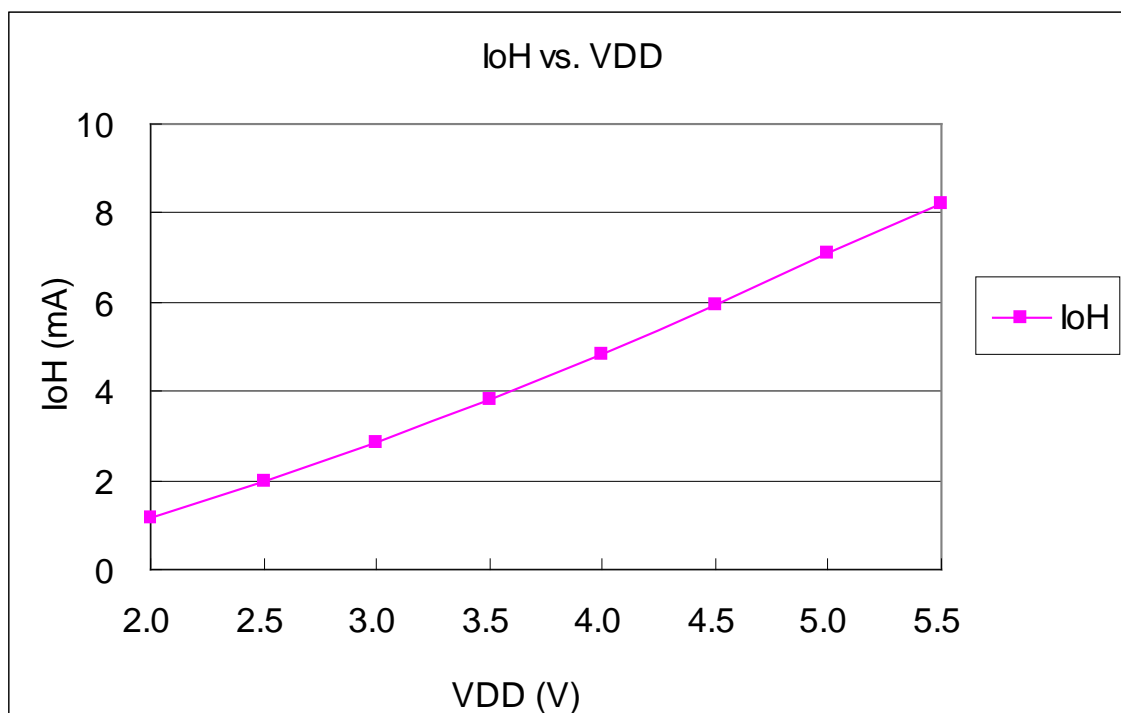

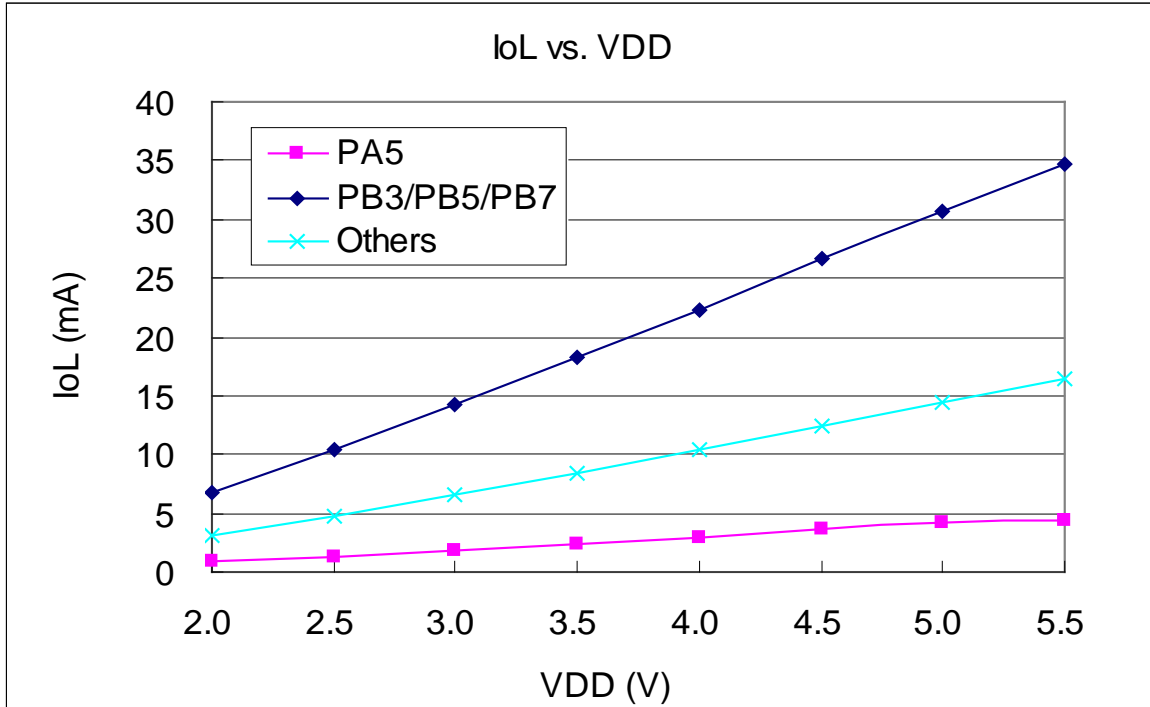

### 4.13. Typical IO input high/low threshold voltage ( $V_{IH}/V_{IL}$ )

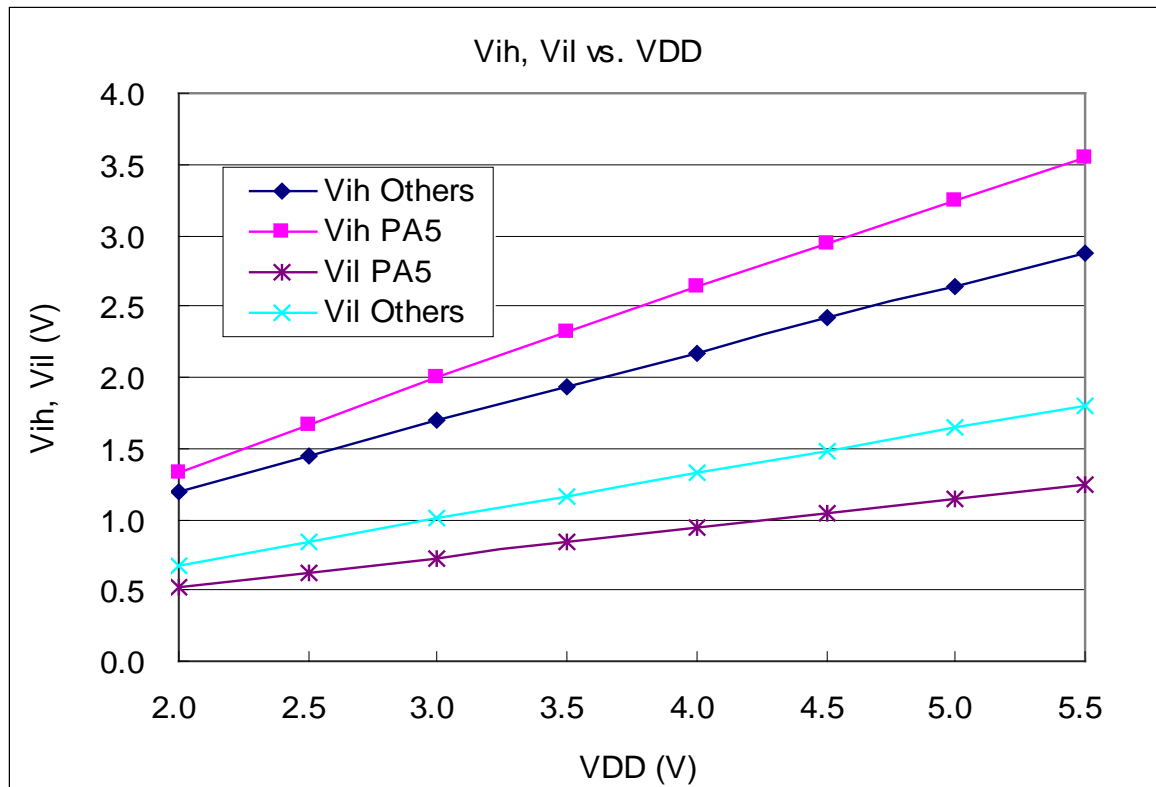

#### 4.14. Typical resistance of IO pull high device

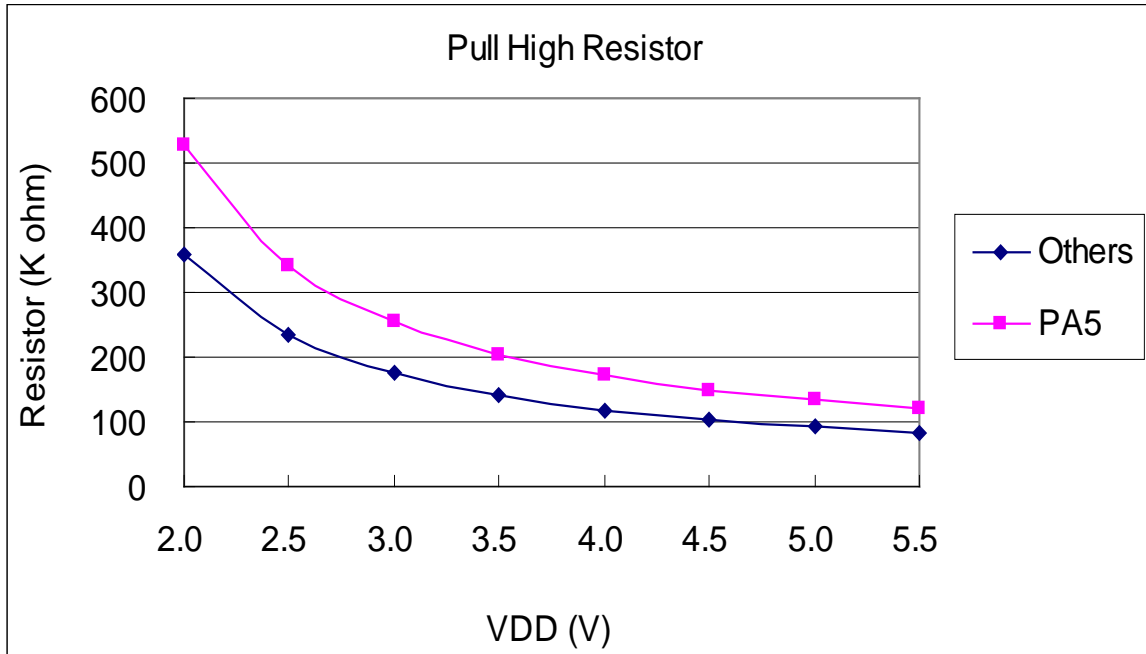

#### 4.15. Typical power down current ( $I_{PD}$ ) and power save current ( $I_{PS}$ )

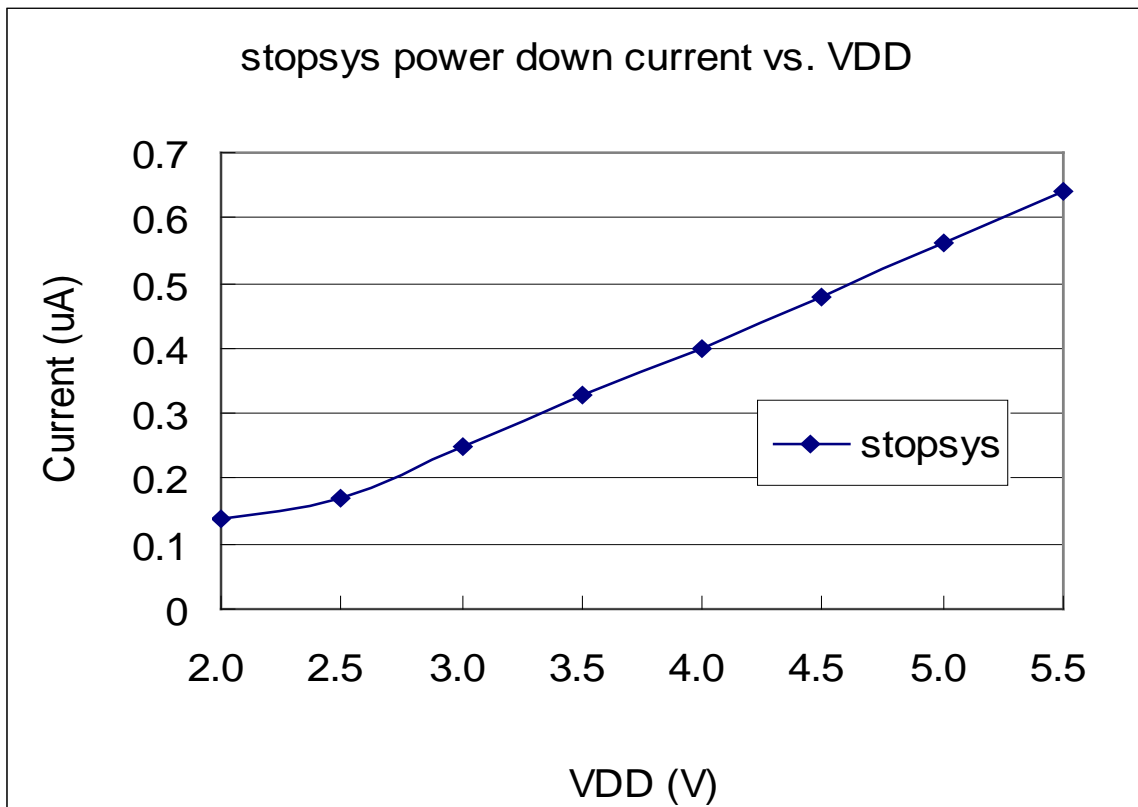



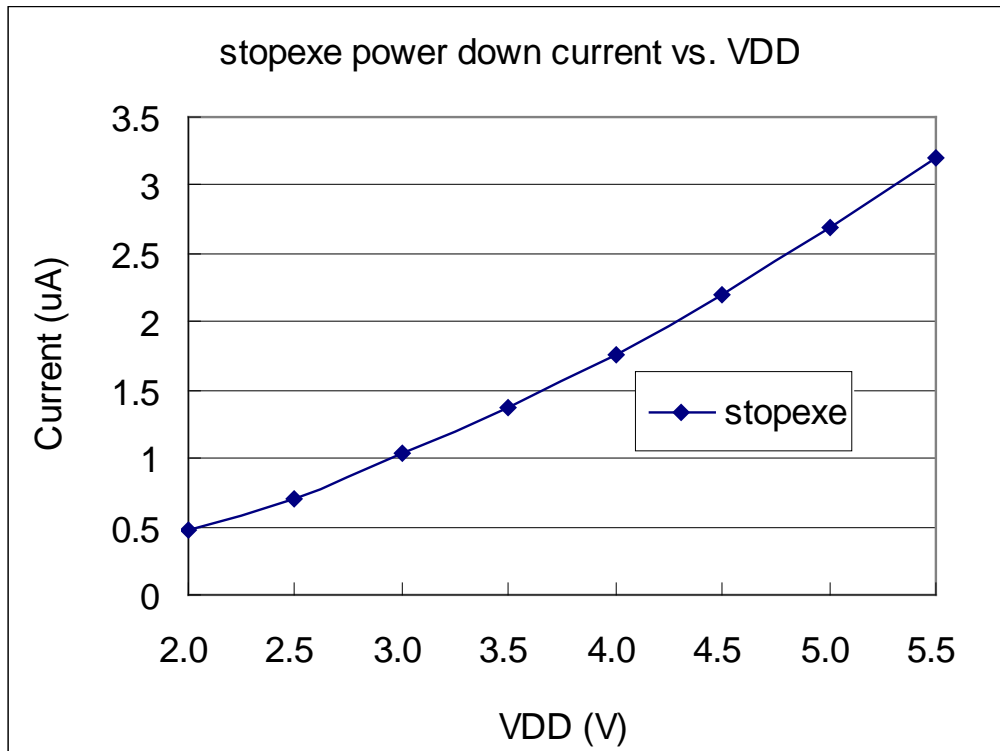

### 5. Functional Description

#### 5.1. Program Memory - OTP

The OTP (One Time Programmable) program memory is used to store the program instructions to be executed. The OTP program memory may contains the data, tables and interrupt entry. After reset, the initial address 0x000 is reserved for system using, so the program will start from 0x001 which is GOTO FPPA0 instruction usually. The interrupt entry is 0x010 if used, the last 16 addresses are reserved for system using, like checksum, serial number, etc. The OTP program memory for PMS152 is 1.25KW that is partitioned as Table 1. The OTP memory from address '0x4E6 to 0x4FF is for system using, address space from 0x002 to 0x00F and from 0x011 to 0x4E5 are user program spaces.

Address	Function
0x000	System Using
0x001	GOTO FPPA0 instruction
0x002	User program
•	•
0x00F	User program
0x010	Interrupt entry address
0x011	User program
•	•
0x4E5	User program
0x4E6	System Using
•	•
0x4FF	System Using

Table 1: Program Memory Organization

#### 5.2. Boot Procedure

POR (Power-On-Reset) is used to reset PMS152 when power up. The boot up time can be optional fast or normal. Time for fast boot-up is about 47 ILRC clock cycles whereas 2945 ILRC clock cycles for normal boot-up. Customer must ensure the stability of supply voltage after power up no matter which option is chosen, the power up sequence is shown in the Fig. 1 and  $t_{SBP}$  is the boot up time.

**Please noted, during Power-one-reset, the  $V_{DD}$  must go higher than  $V_{POR}$  to boot-up the MCU.**

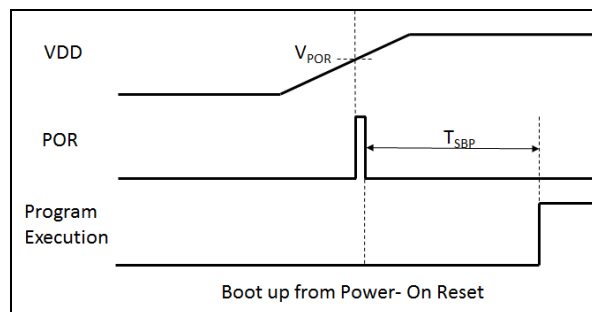
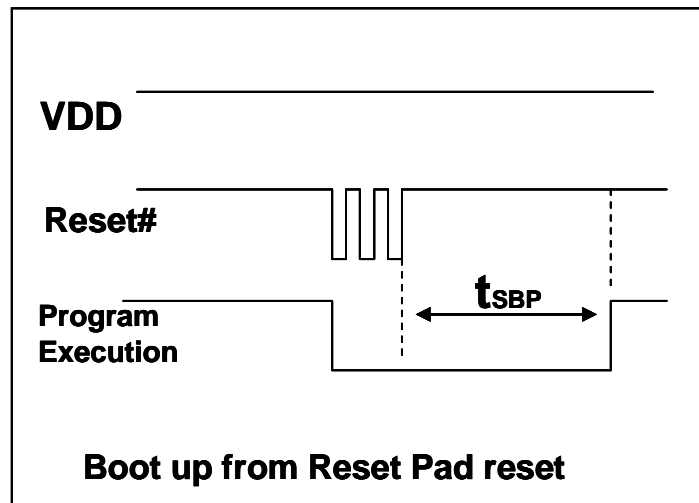
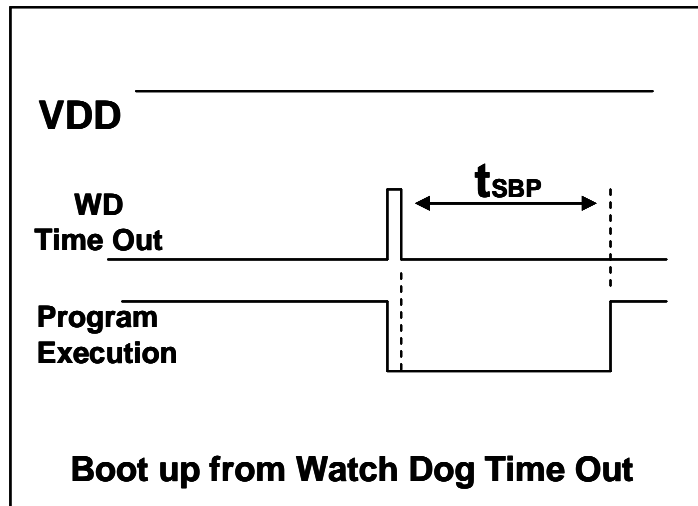
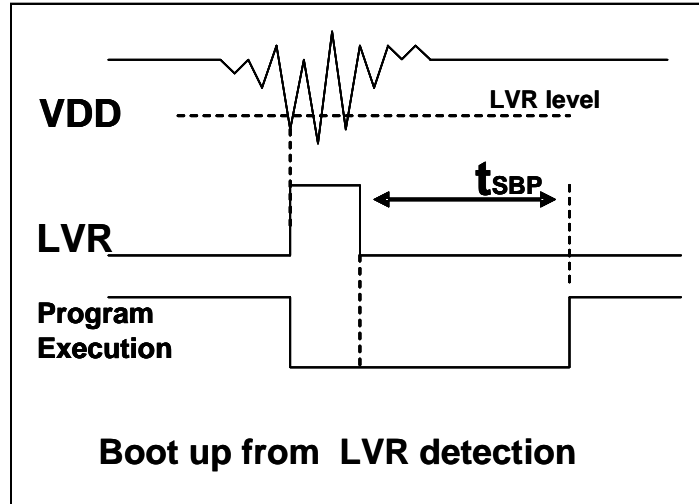

Fig.1: Power-Up Sequence

### 5.2.1. Timing charts for reset conditions



### 5.3. Data Memory - SRAM

The access of data memory can be byte or bit operation. Besides data storage, the SRAM data memory is also served as data pointer of indirect access method and the stack memory.

The stack memory is defined in the data memory. The stack pointer is defined in the stack pointer register; the depth of stack memory of each processing unit is defined by the user. The arrangement of stack memory fully flexible and can be dynamically adjusted by the user.

For indirect memory access mechanism, the data memory is used as the data pointer to address the data byte. All the data memory could be the data pointer; it's quite flexible and useful to do the indirect memory access. Since the data width is 8-bit, all the 80 bytes data memory of PMS152 can be accessed by indirect access mechanism.

### 5.4. Oscillator and Clock

There are three oscillator circuits provided by PMS152: external crystal oscillator (EOSC), internal high RC oscillator (IHRC) and internal low RC oscillator (ILRC), and these three oscillators are enabled or disabled by registers `eoscr.7`, `clkmd.4` and `clkmd.2` independently. User can choose one of these three oscillators as system clock source and use ***clkmd*** register to target the desired frequency as system clock to meet different applications.

Oscillator Module	Enable/Disable
EOSC	<b><code>eoscr.7</code></b>
IHRC	<b><code>clkmd.4</code></b>
ILRC	<b><code>clkmd.2</code></b>

Table 2: Three oscillation circuits

#### 5.4.1. Internal High RC oscillator and Internal Low RC oscillator

After boot-up, the IHRC and ILRC oscillators are enabled. The frequency of IHRC can be calibrated to eliminate process variation by ***ihrcr*** register; normally it is calibrated to 16MHz. The frequency deviation can be within 1.5% normally after calibration under the calibrated voltage, however, it still drifts slightly with supply voltage and operating temperature, the total drift rate is around  $\pm 5\%$  for  $V_{DD}=2.2V\sim 5.5V$  and  $-20^{\circ}C\sim 70^{\circ}C$  operating conditions. Please refer to the measurement chart for IHRC frequency verse  $V_{DD}$  and IHRC frequency verse temperature.

The frequency will vary by process, supply voltage and temperature, please refer to DC specification and do not use for accurate timing application.

### 5.4.2. Chip calibration

The IHRC frequency and band-gap reference voltage may be different chip by chip due to manufacturing variation, PMS152 provide the IHRC frequency calibration to eliminate this variation, and this function can be selected when compiling user's program and the command will be inserted into user's program automatically. The calibration command is shown as below:

`.ADJUST_IC SYSCLK=IHRC/(p1), IHRC=(p2)MHz, VDD=(p3)V;`

Where, **p1**=2, 4, 8, 16, 32; In order to provide different system clock.

**p2**=14 ~ 18; In order to calibrate the chip to different frequency, 16MHz is the usually one.

**p3**=1.8 ~ 5.5; In order to calibrate the chip under different supply voltage.

### 5.4.3. IHRC Frequency Calibration and System Clock

During compiling the user program, the options for IHRC calibration and system clock are shown as Table 3:

<b>SYSCLK</b>	<b>CLKMD</b>	<b>IHRCR</b>	<b>Description</b>
○ Set IHRC / 2	= 34h (IHRC / 2)	Calibrated	IHRC calibrated to 16MHz, CLK=8MHz (IHRC/2)
○ Set IHRC / 4	= 14h (IHRC / 4)	Calibrated	IHRC calibrated to 16MHz, CLK=4MHz (IHRC/4)
○ Set IHRC / 8	= 3Ch (IHRC / 8)	Calibrated	IHRC calibrated to 16MHz, CLK=2MHz (IHRC/8)
○ Set IHRC / 16	= 1Ch (IHRC / 16)	Calibrated	IHRC calibrated to 16MHz, CLK=1MHz (IHRC/16)
○ Set IHRC / 32	= 7Ch (IHRC / 32)	Calibrated	IHRC calibrated to 16MHz, CLK=0.5MHz (IHRC/32)
○ Set ILRC	= E4h (ILRC / 1)	Calibrated	IHRC calibrated to 16MHz, CLK=ILRC
○ Disable	No change	No Change	IHRC not calibrated, CLK not changed

Table 3: Options for IHRC Frequency Calibration

Usually, `.ADJUST_IC` will be the first command after boot up, in order to set the target operating frequency whenever starting the system. The program code for IHRC frequency calibration is executed only one time that occurs in writing the codes into OTP memory; after then, it will not be executed again. If the different option for IHRC calibration is chosen, the system status is also different after boot. The following shows the status of PMS152 for different option:

(1) `.ADJUST_IC SYSCLK=IHRC/2, IHRC=16MHz, VDD=5V`

After boot up, CLKMD = 0x34:

- ◆ IHRC frequency is calibrated to 16MHz@V<sub>DD</sub>=5V and IHRC module is enabled
- ◆ System CLK = IHRC/2 = 8MHz
- ◆ Watchdog timer is disabled, ILRC is enabled, PA5 is in input mode

(2) `.ADJUST_IC SYSCLK=IHRC/4, IHRC=16MHz, VDD=3.3V`

After boot up, CLKMD = 0x14:

- ◆ IHRC frequency is calibrated to 16MHz@V<sub>DD</sub>=3.3V and IHRC module is enabled
- ◆ System CLK = IHRC/4 = 4MHz
- ◆ Watchdog timer is disabled, ILRC is enabled, PA5 is in input mode

(3) `.ADJUST_IC SYSCLK=IHRC/8, IHRC=16MHz, VDD=2.5V`

After boot up, CLKMD = 0x3C:

- ◆ IHRC frequency is calibrated to 16MHz@V<sub>DD</sub>=2.5V and IHRC module is enabled
- ◆ System CLK = IHRC/8 = 2MHz
- ◆ Watchdog timer is disabled, ILRC is enabled, PA5 is in input mode

(4) .ADJUST\_IC    SYSCLK=IHRC/16, IHRC=16MHz, V<sub>DD</sub>=2.5V

After boot up, CLKMD = 0x1C:

- ◆ IHRC frequency is calibrated to 16MHz@V<sub>DD</sub>=2.5V and IHRC module is enabled
- ◆ System CLK = IHRC/16 = 1MHz
- ◆ Watchdog timer is disabled, ILRC is enabled, PA5 is in input mode

(5) .ADJUST\_IC    SYSCLK=IHRC/32, IHRC=16MHz, V<sub>DD</sub>=5V

After boot up, CLKMD = 0x7C:

- ◆ IHRC frequency is calibrated to 16MHz@V<sub>DD</sub>=5V and IHRC module is enabled
- ◆ System CLK = IHRC/32 = 500KHz
- ◆ Watchdog timer is disabled, ILRC is enabled, PA5 is in input mode

(6) .ADJUST\_IC    SYSCLK=ILRC, IHRC=16MHz, V<sub>DD</sub>=5V

After boot up, CLKMD = 0xE4:

- ◆ IHRC frequency is calibrated to 16MHz@V<sub>DD</sub>=5V and IHRC module is disabled
- ◆ System CLK = ILRC
- ◆ Watchdog timer is disabled, ILRC is enabled, PA5 is input mode

(7) .ADJUST\_IC    DISABLE

After boot up, CLKMD is not changed (Do nothing):

- ◆ IHRC is not calibrated
- ◆ System CLK = ILRC or IHRC/64 (by Boot-up\_Time)
- ◆ Watchdog timer is enabled, ILRC is enabled, PA5 is in input mode,

#### 5.4.4. External Crystal Oscillator

If crystal oscillator is used, a crystal or resonator is required between X1 and X2. Fig.2 shows the hardware connection under this application; the range of operating frequency of crystal oscillator can be from 32 KHz to 4MHz, depending on the crystal placed on; higher frequency oscillator than 4MHz is NOT supported.

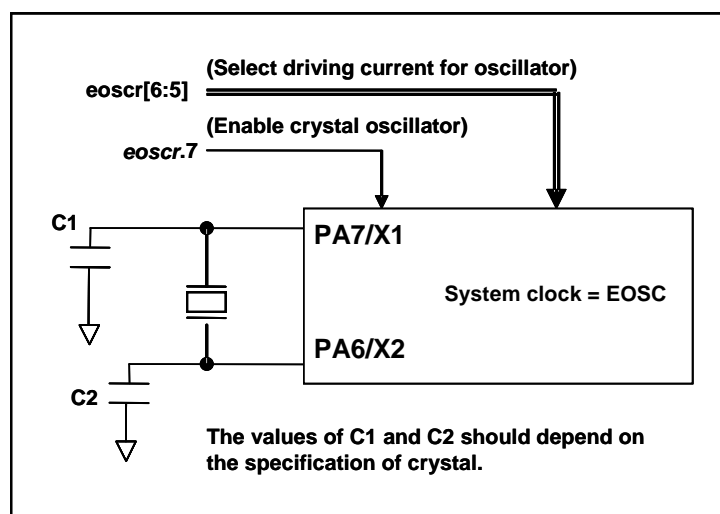

Fig.2: Connection of crystal oscillator

Besides crystal, external capacitor and options of PMS152 should be fine tuned in *eoscr* (0x0b) register to have good sinusoidal waveform. The *eoscr.7* is used to enable crystal oscillator module, *eoscr.6* and *eoscr.5* are used to set the different driving current to meet the requirement of different frequency of crystal oscillator:

- ◆ *eoscr*[6:5]=01 : Low driving capability, for lower frequency, ex: 32KHz crystal oscillator (**reserved**)
- ◆ *eoscr*[6:5]=10 : Middle driving capability, for middle frequency, ex: 1MHz crystal oscillator
- ◆ *eoscr*[6:5]=11 : High driving capability, for higher frequency, ex: 4MHz crystal oscillator

Table 4 shows the recommended values of C1 and C2 for different crystal oscillator; the measured start-up time under its corresponding conditions is also shown. Since the crystal or resonator had its own characteristic, the capacitors and start-up time may be slightly different for different type of crystal or resonator, please refer to its specification for proper values of C1 and C2.

Frequency	C1	C2	Measured Start-up time	Conditions
4MHz	4.7pF	4.7pF	6ms	( <i>eoscr</i> [6:5]=11)
1MHz	10pF	10pF	11ms	( <i>eoscr</i> [6:5]=10)
32KHz ( <b>reserved</b> )	22pF	22pF	450ms	( <i>eoscr</i> [6:5]=01)

Table 4: Recommend values of C1 and C2 for crystal and resonator oscillators

When using the crystal oscillator, user must pay attention to the stable time of oscillator after enabling it, the stable time of oscillator will depend on frequency “crystal type” external capacitor and supply voltage. Before switching the system to the crystal oscillator, user must make sure the oscillator is stable; the reference program is shown as below:

```

void  FPPA0 (void)
{
    . ADJUST_IC  SYSCLK=IHRC/16, IHRC=16MHz, VDD=5V
    $ EOSCR  Enable, 4MHz;           // EOSCR = 0b110_00000;

    $ T16M    EOSC, /1, BIT13;      // while T16.Bit13 0 => 1, Intrq.T16 => 1
                                     // suppose crystal osc. Is stable

    WORD     count = 0;
    stt16 count;
    Intrq.T16 = 0;
    while(!Intrq.T16) NULL;        // count fm 0x0000 to 0x2000, then trigger INTRQ.T16
    clkmd    = 0xA4;               // switch system clock to EOSC;
    ...
}

```

Please notice that the crystal oscillator should be fully turned off before entering the power-down mode, in order to avoid unexpected wakeup event.

### 5.4.5. System Clock and LVR level

The clock source of system clock comes from EOSC, IHRC and ILRC, the hardware diagram of system clock in the PMS152 is shown as Fig.3.

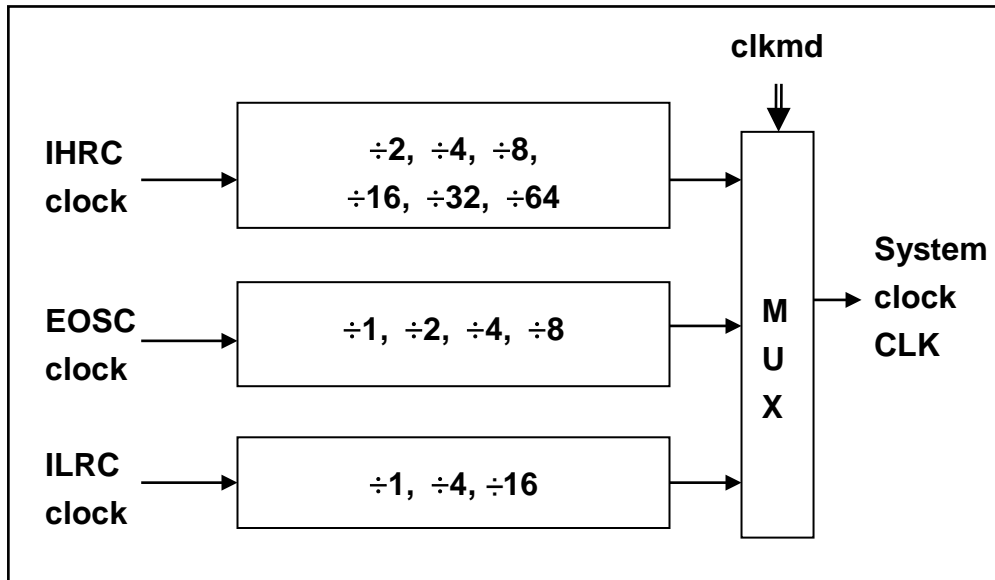

Fig.3: Options of System Clock

User can choose different operating system clock depends on its requirement; the selected operating system clock should be combined with supply voltage and LVR level to make system stable. The LVR level will be selected during compilation Please refer to Section 4.1.



### 5.4.6. System Clock Switching

After IHRC calibration, user may want to switch system clock to a new frequency or may switch system clock at any time to optimize the system performance and power consumption. Basically, the system clock of PMS152 can be switched among IHRC, ILRC and EOSC by setting the **clkmd** register at any time; system clock will be the new one after writing to **clkmd** register immediately. Please notice that the original clock module can NOT be turned off at the same time as writing command to **clkmd** register. The examples are shown as below and more information about clock switching, please refer to the “Help” -> “Application Note” -> “IC Introduction” -> “Register Introduction” -> CLKMD”.

**Case 1:** Switching system clock from ILRC to IHRC/2

```

... // system clock is ILRC
CLKMD = 0x34 ; // switch to IHRC/2, ILRC CAN NOT be disabled here
CLKMD.2 = 0 ; // ILRC CAN be disabled at this time
...

```

**Case 2:** Switching system clock from ILRC to EOSC

```

... // system clock is ILRC
CLKMD = 0xA6 ; // switch to IHRC, ILRC CAN NOT be disabled here
CLKMD.2 = 0 ; // ILRC CAN be disabled at this time
...

```

**Case 3:** Switching system clock from IHRC/2 to ILRC

```

... // system clock is IHRC/2
CLKMD = 0xF4 ; // switch to ILRC, IHRC CAN NOT be disabled here
CLKMD.4 = 0 ; // IHRC CAN be disabled at this time
...

```

**Case 4:** Switching system clock from IHRC/2 to EOSC

```

... // system clock is IHRC/2
CLKMD = 0xB0 ; // switch to EOSC, IHRC CAN NOT be disabled here
CLKMD.4 = 0 ; // IHRC CAN be disabled at this time
...

```

**Case 5:** Switching system clock from IHRC/2 to IHRC/4

```

... // system clock is IHRC/2, ILRC is enabled here
CLKMD = 0X14 ; // switch to IHRC/4
...

```

**Case 6:** System may hang if it is to switch clock and turn off original oscillator at the same time

```

... // system clock is ILRC
CLKMD = 0x30 ; // CAN NOT switch clock from ILRC to IHRC/2 and turn off ILRC oscillator at the same time

```

### 5.5. Comparator

One hardware comparator is built inside the PMS152; Fig.4 shows its hardware diagram. It can compare signals between two pins or with either internal reference voltage  $V_{\text{internal R}}$  or internal band-gap reference voltage. The two signals to be compared, one is the plus input and the other one is the minus input. For the minus input of comparator can be PA3, PA4, Internal band-gap 1.20 volt, PB6, PB7 or  $V_{\text{internal R}}$  selected by bit [3:1] of *gpcc* register, and the plus input of comparator can be PA4 or  $V_{\text{internal R}}$  selected by bit 0 of *gpcc* register. The output result can be enabled to output to PA0 directly, or sampled by Time2 clock (TM2\_CLK) which comes from Timer2 module. The output can be also inversed the polarity by bit 4 of *gpcc* register, the comparator output can be used to request interrupt service.

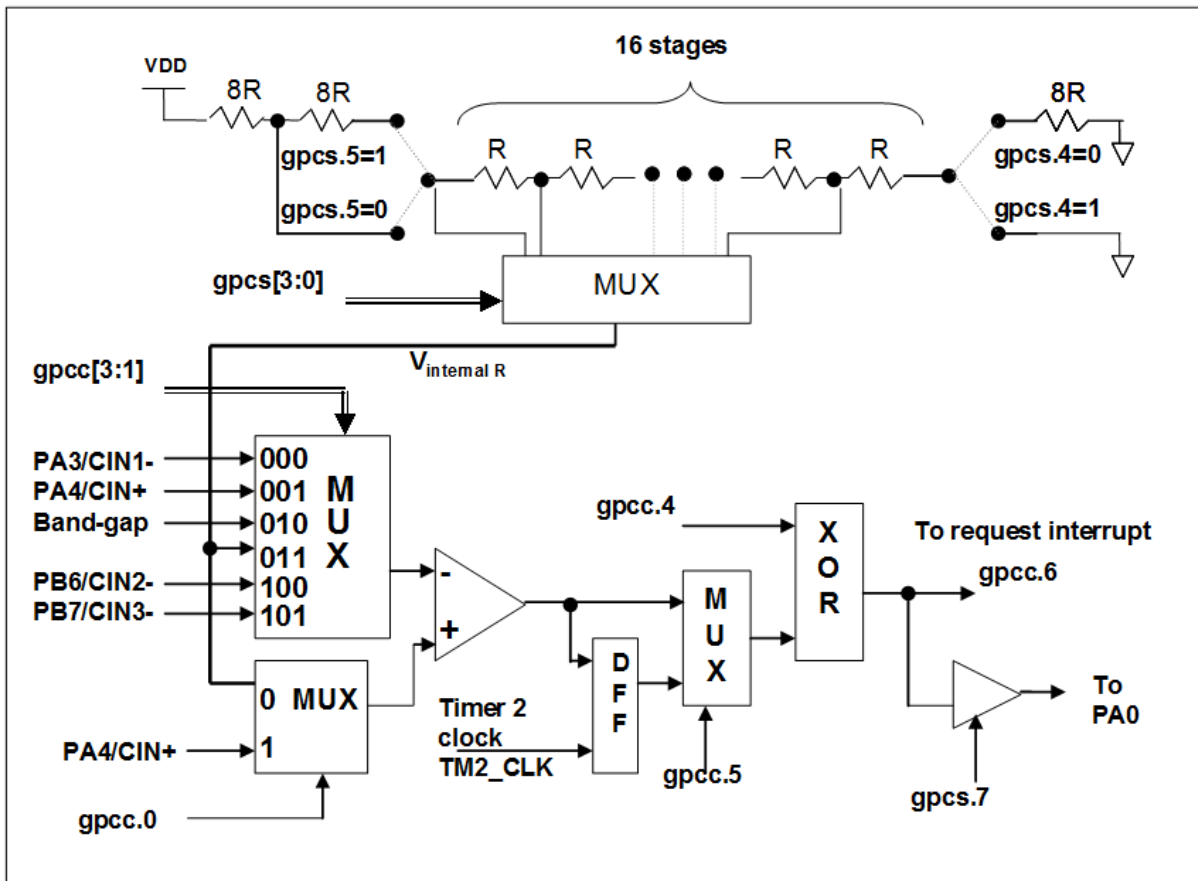

Fig.4: Hardware diagram of comparator

### 5.5.1 Internal reference voltage ( $V_{\text{internal R}}$ )

The internal reference voltage  $V_{\text{internal R}}$  is built by series resistance to provide different level of reference voltage, bit 4 and bit 5 of **gpcs** register are used to select the maximum and minimum values of  $V_{\text{internal R}}$  and bit [3:0] of **gpcs** register are used to select one of the voltage level which is divided-by-16 from the defined maximum level to minimum level. Fig.5 to Fig.8 shows four conditions to have different reference voltage  $V_{\text{internal R}}$ . By setting the **gpcs** register, the internal reference voltage  $V_{\text{internal R}}$  can be ranged from  $(1/32)*V_{\text{DD}}$  to  $(3/4)*V_{\text{DD}}$ .

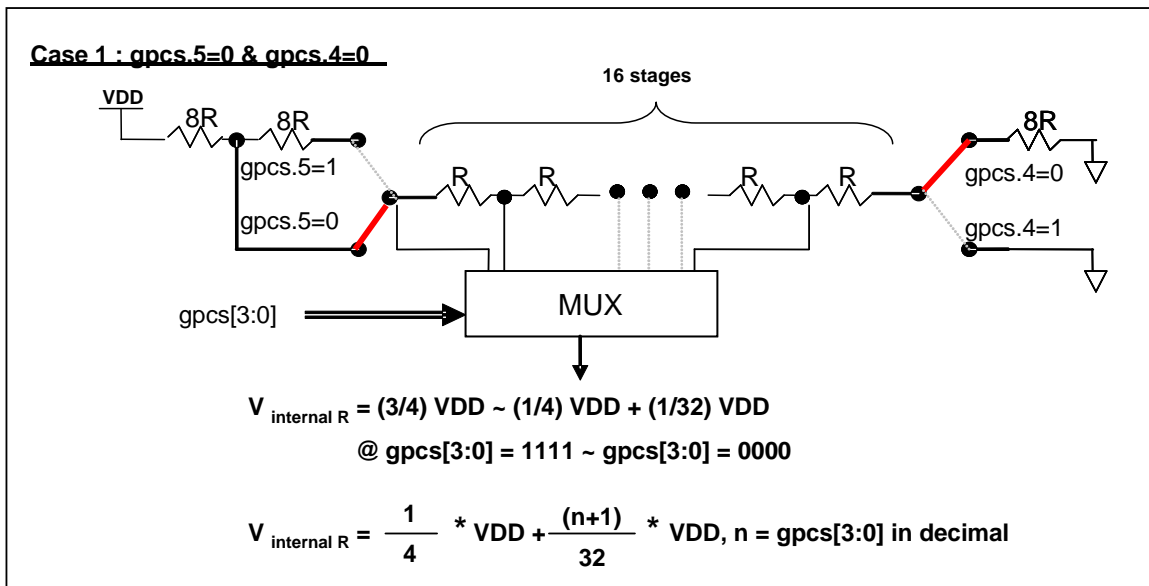

Fig.5:  $V_{\text{internal R}}$  hardware connection if gpcs.5=0 and gpcs.4=0

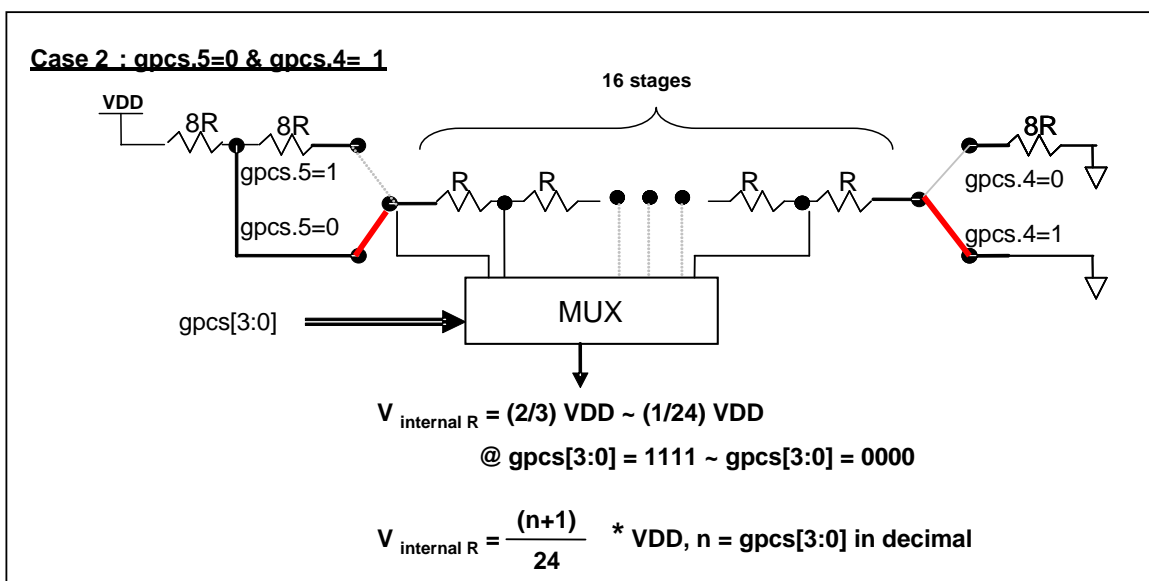

Fig.6:  $V_{\text{internal R}}$  hardware connection if gpcs.5=0 and gpcs.4=1

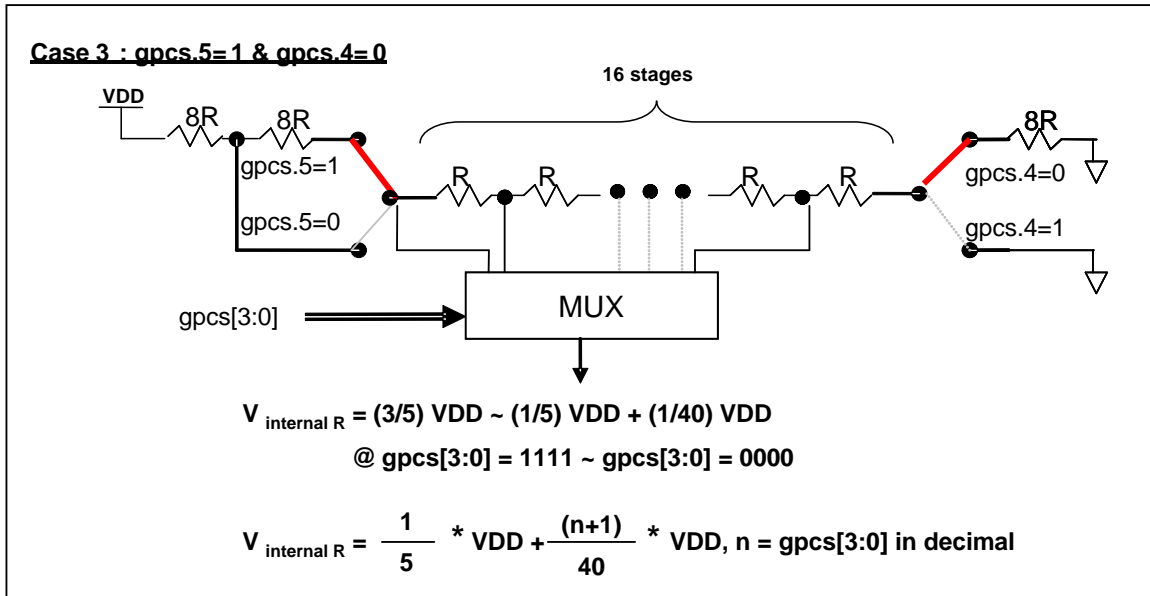

Fig.7:  $V_{\text{internal R}}$  hardware connection if gpcs.5=1 and gpcs.4=0

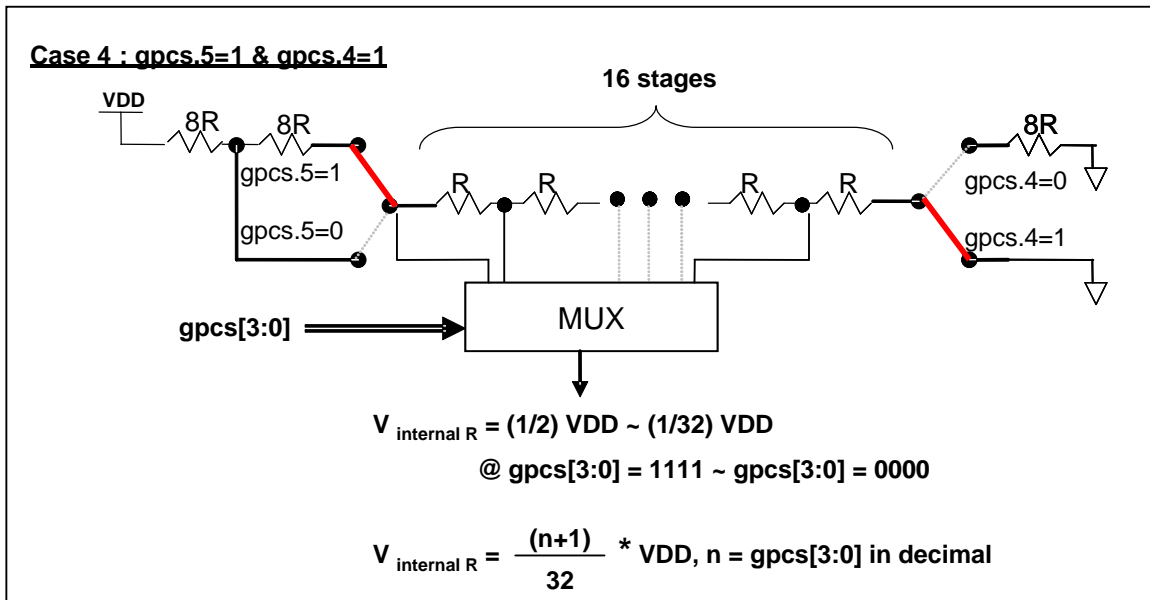

Fig.8:  $V_{\text{internal R}}$  hardware connection if gpcs.5=1 and gpcs.4=1

### 5.5.2 Using the comparator

#### Case 1:

Choosing PA3 as minus input and  $V_{internal R}$  with  $(18/32)*V_{DD}$  voltage level as plus input.  $V_{internal R}$  is configured as the above Figure “gpcs[5:4] = 2b'00” and gpcs [3:0] = 4b'1001 (n=9) to have  $V_{internal R} = (1/4)*V_{DD} + [(9+1)/32]*V_{DD} = [(9+9)/32]*V_{DD} = (18/32)*V_{DD}$ .

```

gpcs = 0b1_0_00_1001;           //  $V_{internal R} = V_{DD}*(18/32)$ 
gpcc = 0b1_0_0_0_000_0;         // enable comp, - input: PA3, + input:  $V_{internal R}$ 
padier = 0bxxxx_0_xxx;          // disable PA3 digital input to prevent leakage current

```

or

```

$ GPCS     $V_{DD}*18/32$ ;
$ GPCC    Enable, N_PA3, P_R;    // - input: N_xx, + input: P_R( $V_{internal R}$ )
PADIER = 0bxxxx_0_xxx;

```

#### Case 2:

Choosing  $V_{internal R}$  as minus input with  $(14/32)*V_{DD}$  voltage level and PA4 as plus input, the comparator result will be inversed and then output to PA0.  $V_{internal R}$  is configured as the above Figure “gpcs[5:4] = 2b'10” and gpcs [3:0] = 4b'1101 (n=13) to have  $V_{internal R} = (1/5)*V_{DD} + [(13+1)/40]*V_{DD} = [(13+9)/40]*V_{DD} = (22/40)*V_{DD}$ .

```

gpcs = 0b1_0_10_1101;           // output to PA0,  $V_{internal R} = V_{DD}*(22/40)$ 
gpcc = 0b1_0_0_1_011_1;         // Inverse output, - input:  $V_{internal R}$ , + input: PA4
padier = 0bxxx_0_xxxx;          // disable PA4 digital input to prevent leakage current

```

or

```

$ GPCS    Output,  $V_{DD}*22/40$ ;
$ GPCC    Enable, Inverse, N_R, P_PA4; // - input: N_R( $V_{internal R}$ ), + input: P_xx
PADIER = 0bxxx_0_xxxx;

```

Note: When selecting output to PA0 output, GPCS will affect the PA3 output function in ICE. Though the IC is fine, be careful to avoid this error during emulation.

### 5.5.3 Using the comparator and band-gap 1.20V

The internal band-gap module can provide 1.20 volt, it can measure the external supply voltage level. The band-gap 1.20 volt is selected as minus input of comparator and  $V_{\text{internal R}}$  is selected as plus input, the supply voltage of  $V_{\text{internal R}}$  is  $V_{\text{DD}}$ , the  $V_{\text{DD}}$  voltage level can be detected by adjusting the voltage level of  $V_{\text{internal R}}$  to compare with band-gap. If  $N$  (gpcs[3:0] in decimal) is the number to let  $V_{\text{internal R}}$  closest to band-gap 1.20 volt, the supply voltage  $V_{\text{DD}}$  can be calculated by using the following equations:

For using Case 1:  $V_{\text{DD}} = [ 32 / (N+9) ] * 1.20 \text{ volt} ;$

For using Case 2:  $V_{\text{DD}} = [ 24 / (N+1) ] * 1.20 \text{ volt} ;$

For using Case 3:  $V_{\text{DD}} = [ 40 / (N+9) ] * 1.20 \text{ volt} ;$

For using Case 4:  $V_{\text{DD}} = [ 32 / (N+1) ] * 1.20 \text{ volt} ;$

#### Case 1:

```

$ GPCS  $V_{\text{DD}} * 12 / 40$ ;           // 4.0V * 12/40 = 1.2V
$ GPCC Enable, BANDGAP, P_R;     // - input: BANDGAP, + input: P_R( $V_{\text{internal R}}$ )
....
if (GPC_Out)                     // or GPCC.6
{                                  // when  $V_{\text{DD}} > 4V$ 
}
else
{                                  // when  $V_{\text{DD}} < 4V$ 
}

```

### 5.6 16-bit Timer (Timer16)

A 16-bit hardware timer (Timer16) is implemented in the PMS152, the clock sources of Timer16 may come from system clock (CLK), clock of external crystal oscillator (EOSC), internal high RC oscillator (IHRC), internal low RC oscillator (ILRC), PA4 and PA0, a multiplex is used to select clock output for the clock source. Before sending clock to the counter16, a pre-scaling logic with divided-by-1, 4, 16, and 64 is used for wide range counting. The 16-bit counter performs up-counting operation only, the counter initial values can be stored from memory by *stt16* instruction and the counting values can be loaded to memory by *ldt16* instruction. A selector is used to select the interrupt condition of Timer16, whenever overflow occurs, the Timer16 interrupt can be triggered. The hardware diagram of Timer16 is shown as Fig.9. The interrupt source of Timer16 comes from one of bit 8 to 15 of 16-bit counter, and the interrupt type can be rising edge trigger or falling edge trigger which is specified in the bit 5 of *integs* register (address 0x0C).

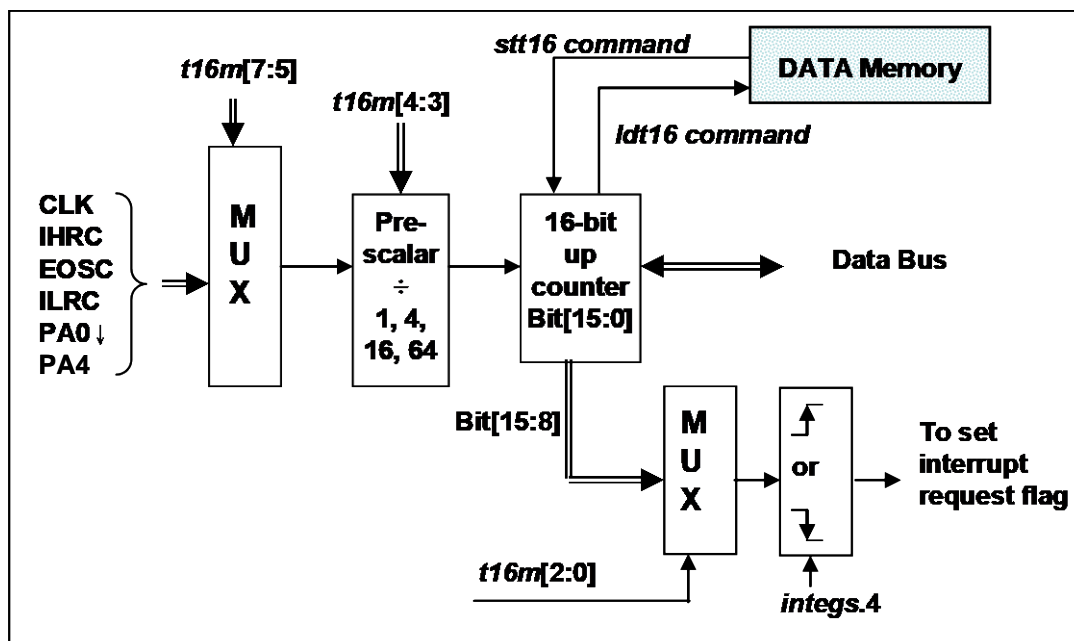

Fig.9: Hardware diagram of Timer16

When using the Timer16, the syntax for Timer16 has been defined in the .INC file. There are three parameters to define the Timer16; 1<sup>st</sup> parameter is used to define the clock source of Timer16, 2<sup>nd</sup> parameter is used to define the pre-scaler and the last one is to define the interrupt source. The detail description is shown as below:

```

T16M      IO_RW      0x06
$ 7~5: STOP, SYSCLK, X, PA4_F, IHRC, EOSC, ILRC, PA0_F // 1st par.
$ 4~3: /1, /4, /16, /64 // 2nd par.
$ 2~0: BIT8, BIT9, BIT10, BIT11, BIT12, BIT13, BIT14, BIT15 // 3d par.

```

User can define the parameters of T16M based on system requirement, some examples are shown below and more examples please refer to “Help → Application Note → IC Introduction → Register Introduction → T16M” in IDE utility.

**\$ T16M SYSCLK, /64, BIT15;**

*// choose (SYSCLK/64) as clock source, every 2<sup>16</sup> clock to set INTRQ.2=1*  
*// if using System Clock = IHRC / 2 = 8 MHz*  
*// SYSCLK/64 = 8 MHz/64 = 125KHz, about every 512 mS to generate INTRQ.2=1*

**\$ T16M EOSC, /1, BIT13;**

*// choose (EOSC/1) as clock source, every 2<sup>14</sup> clocks to generate INTRQ.2=1*  
*// if EOSC=32768 Hz, 32768 Hz/(2<sup>14</sup>) = 2Hz, every 0.5S to generate INTRQ.2=1*

**\$ T16M PA0\_F, /1, BIT8;**

*// choose PA0 as clock source, every 2<sup>9</sup> to generate INTRQ.2=1*  
*// receiving every 512 times PA0 to generate INTRQ.2=1*

**\$ T16M STOP;**

*// stop Timer16 counting*

If Timer16 is operated at free running, the frequency of interrupt can be described as below:

$$F_{INTRQ\_T16M} = F_{clock\ source} \div P \div 2^{n+1}$$

Where, F is the frequency of selected clock source to Timer16;

P is the selection of t16m [4:3]; (1, 4, 16, 64)

N is the n<sup>th</sup> bit selected to request interrupt service, for example: n=10 if bit 10 is selected.



### 5.7 8-bit Timer (Timer2) with PWM generation

An 8-bit hardware timer (Timer2) with PWM generation is implemented in the PMS152. Please refer to Fig.10 show the hardware diagram of Timer2, the clock sources of Timer2 may come from system clock, internal high RC oscillator (IHRC), internal low RC oscillator (ILRC), external crystal oscillator (EOSC), PA0, PB0, PA4 and comparator. Bit [7:4] of register tm2c are used to select the clock of Timer2. If IHRC is selected for Timer2 clock source, the clock sent to Timer2 will keep running when using ICE in halt state. The output of Timer2 can be sent to pin PB2, PA3 or PB4, depending on bit [3:2] of tm2c register. A clock pre-scaling module is provided with divided-by- 1, 4, 16, and 64 options, controlled by bit [6:5] of tm2s register; one scaling module with divided-by-1~31 is also provided and controlled by bit [4:0] of tm2s register. In conjunction of pre-scaling function and scaling function, the frequency of Timer2 clock (TM2\_CLK) can be wide range and flexible.

The Timer2 counter performs 8-bit up-counting operation only; the counter values can be set or read back by tm2ct register. The 8-bit counter will be clear to zero automatically when its values reach for upper bound register in period mode. The upper bound register is used to define the period of timer or duty of PWM. There are two operating modes for Timer2: period mode and PWM mode; period mode is used to generate periodical output waveform or interrupt event; PWM mode is used to generate PWM output waveform with optional 6-bit, 7-bit or 8-bit PWM resolution, Fig.11 shows the timing diagram of Timer2 for both period mode and PWM mode.

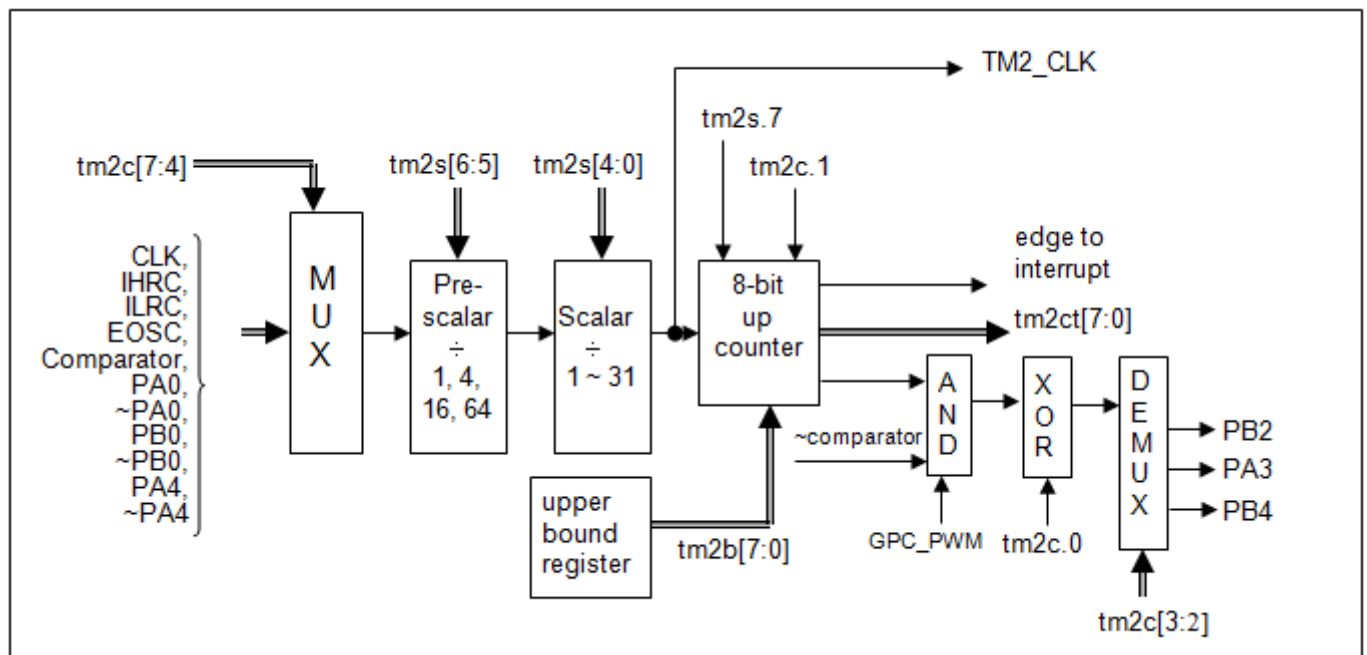

Fig.10: Timer2 hardware diagram

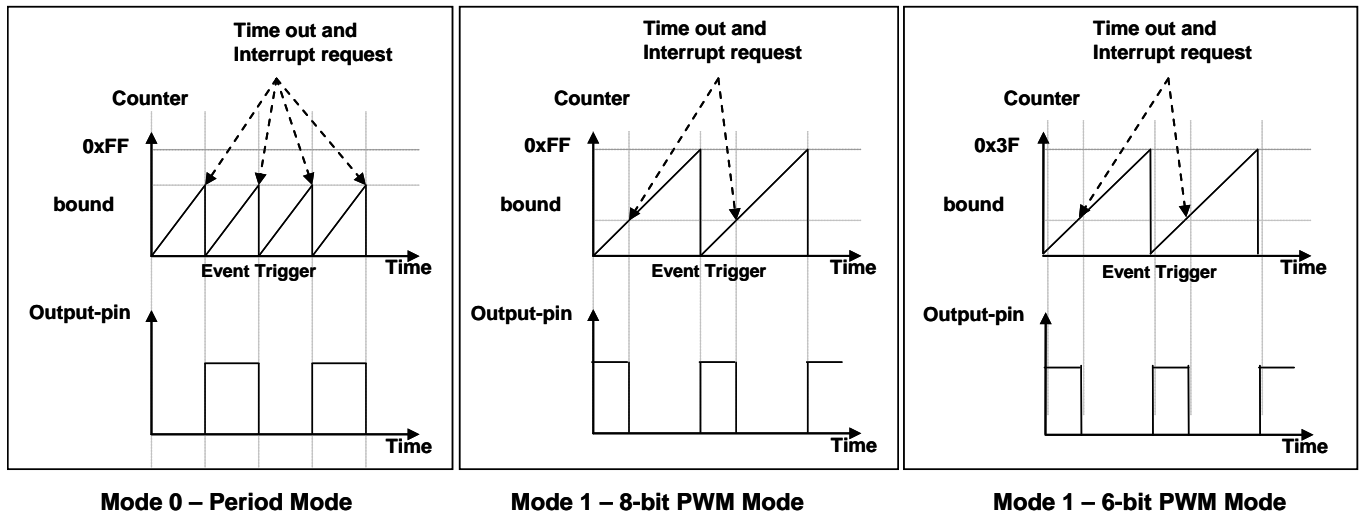

Fig.11: Timing diagram of Timer2 in period mode and PWM mode (tm2c.1=1)

### 5.7.1 Using the Timer2 to generate periodical waveform

If periodical mode is selected, the duty cycle of output is always 50%; its frequency can be summarized as below:

$$\text{Frequency of Output} = Y \div [2 \times (K+1) \times S1 \times (S2+1)]$$

- Where,
- Y = tm2c[7:4] : frequency of selected clock source
  - K = tm2b[7:0] : bound register in decimal
  - S1 = tm2s[6:5] : pre-scalar (1, 4, 16, 64)
  - S2 = tm2s[4:0] : scalar register in decimal (1 ~ 31)

Example 1:

```
tm2c = 0b0001_1000, Y=8MHz
tm2b = 0b0111_1111, K=127
tm2s = 0b0000_00000, S1=1, S2=0
➔ frequency of output = 8MHz ÷ [ 2 × (127+1) × 1 × (0+1) ] = 31.25KHz
```

Example 2:

```
tm2c = 0b0001_1000, Y=8MHz
tm2b = 0b0111_1111, K=127
tm2s[7:0] = 0b0111_11111, S1=64, S2 = 31
➔ frequency of output = 8MHz ÷ ( 2 × (127+1) × 64 × (31+1) ) =15.25Hz
```

Example 3:

tm2c = 0b0001\_1000, Y=8MHz

tm2b = 0b0000\_1111, K=15

tm2s = 0b0000\_00000, S1=1, S2=0

➔ frequency of output =  $8\text{MHz} \div (2 \times (15+1) \times 1 \times (0+1)) = 250\text{KHz}$

Example 4:

tm2c = 0b0001\_1000, Y=8MHz

tm2b = 0b0000\_0001, K=1

tm2s = 0b0000\_00000, S1=1, S2=0

➔ frequency of output =  $8\text{MHz} \div (2 \times (1+1) \times 1 \times (0+1)) = 2\text{MHz}$

The sample program for using the Timer2 to generate periodical waveform from PA3 is shown as below:

```

Void FPPA0 (void)
{
    . ADJUST_IC  SYSCLK=IHRC/2, IHRC=16MHz, VDD=5V
    ...
    tm2ct = 0x0;
    tm2b = 0x7f;
    tm2s = 0b_00_00001;           // 8-bit PWM, pre-scalar = 1, scalar = 2
    tm2c = 0b0001_10_0_0;        // system clock, output=PA3, period mode
    while(1)
    {
        nop;
    }
}

```

### 5.7.2 Using the Timer2 to generate 8-bit PWM waveform

If 8-bit PWM mode is selected, it should set  $tm2c[1]=1$  and  $tm2s[7]=0$ , the frequency and duty cycle of output waveform can be summarized as below:

$$\text{Frequency of Output} = Y \div [256 \times S1 \times (S2+1)]$$

$$\text{Duty of Output} = (K + 1) \div 256$$

Where,  $Y = tm2c[7:4]$  : frequency of selected clock source

$K = tm2b[7:0]$  : bound register in decimal

$S1 = tm2s[6:5]$  : pre-scalar (1, 4, 16, 64)

$S2 = tm2s[4:0]$  : scalar register in decimal (1 ~ 31)

#### Example 1:

$tm2c = 0b0001\_1010$ ,  $Y=8MHz$

$tm2b = 0b0111\_1111$ ,  $K=127$

$tm2s = 0b0000\_00000$ ,  $S1=1$ ,  $S2=0$

→ frequency of output =  $8MHz \div (256 \times 1 \times (0+1)) = 31.25KHz$

→ duty of output =  $[(127+1) \div 256] \times 100\% = 50\%$

#### Example 2:

$tm2c = 0b0001\_1010$ ,  $Y=8MHz$

$tm2b = 0b0111\_1111$ ,  $K=127$

$tm2s = 0b0111\_11111$ ,  $S1=64$ ,  $S2=31$

→ frequency of output =  $8MHz \div (256 \times 64 \times (31+1)) = 15.25Hz$

→ duty of output =  $[(127+1) \div 256] \times 100\% = 50\%$

#### Example 3:

$tm2c = 0b0001\_1010$ ,  $Y=8MHz$

$tm2b = 0b1111\_1111$ ,  $K=255$

$tm2s = 0b0000\_00000$ ,  $S1=1$ ,  $S2=0$

→ PWM output keep high

→ duty of output =  $[(255+1) \div 256] \times 100\% = 100\%$

#### Example 4:

$tm2c = 0b0001\_1010$ ,  $Y=8MHz$

$tm2b = 0b0000\_1001$ ,  $K = 9$

$tm2s = 0b0000\_00000$ ,  $S1=1$ ,  $S2=0$

→ frequency of output =  $8MHz \div (256 \times 1 \times (0+1)) = 31.25KHz$

→ duty of output =  $[(9+1) \div 256] \times 100\% = 3.9\%$

The sample program for using the Timer2 to generate PWM waveform from PA3 is shown as below:

```

void  FPPA0 (void)
{
    .ADJUST_IC    SYSCLK=IHRC/2, IHRC=16MHz, VDD=5V
    wdreset;
    tm2ct = 0x0;
    tm2b = 0x7f;
    tm2s = 0b0_00_00001;           //    8-bit PWM, pre-scalar = 1, scalar = 2
    tm2c = 0b0001_10_1_0;         //    system clock, output=PA3, PWM mode
    while(1)
    {
        nop;
    }
}

```

### 5.7.3 Using the Timer2 to generate 6-bit PWM waveform

If 6-bit PWM mode is selected, it should set **tm2c[1]=1** and **tm2s[7]=1**, the frequency and duty cycle of output waveform can be summarized as below:

$$\text{Frequency of Output} = Y \div [64 \times S1 \times (S2+1) ]$$

$$\text{Duty of Output} = [( K + 1 ) \div 64] \times 100\%$$

Where,    tm2c[7:4] = Y : frequency of selected clock source  
           tm2b[7:0] = K : bound register in decimal  
           tm2s[6:5] = S1 : pre-scalar (1, 4, 16, 64)  
           tm2s[4:0] = S2 : scalar register in decimal (1 ~ 31)

Users can set Timer2 to be 7-bit PWM mode instead of 6-bit mode by using **TM2\_Bit** code option. At that time, the calculation factors of the above equations become 128 instead of 64.

#### Example 1:

```

tm2c = 0b0001_1010, Y=8MHz
tm2b = 0b0001_1111, K=31
tm2s = 0b1000_00000, S1=1, S2=0
→ frequency of output = 8MHz ÷ ( 64 × 1 × (0+1) ) = 125KHz
→ duty = [(31+1) ÷ 64] × 100% = 50%

```

#### Example 2:

```

tm2c = 0b0001_1010, Y=8MHz
tm2b = 0b0001_1111, K=31
tm2s = 0b1111_11111, S1=64, S2=31
→ frequency of output = 8MHz ÷ ( 64 × 64 × (31+1) ) = 61.03 Hz
→ duty of output = [(31+1) ÷ 64] × 100% = 50%

```

Example 3:

```

tm2c = 0b0001_1010, Y=8MHz
tm2b = 0b0011_1111, K=63
tm2s = 0b1000_00000, S1=1, S2=0
→ PWM output keep high
→ duty of output = [(63+1) ÷ 64] × 100% = 100%
    
```

Example 4:

```

tm2c = 0b0001_1010, Y=8MHz
tm2b = 0b0000_0000, K=0
tm2s = 0b1000_00000, S1=1, S2=0
→ frequency = 8MHz ÷ ( 64 × 1 × (0+1) ) = 125KHz
→ duty = [(0+1) ÷ 64] × 100% =1.5%
    
```

### 5.8 11-bit PWM Generators

One set of triple 11-bit SuLED (Super LED) hardware PWM generator is implemented in the PMS152. It consists of three PWM generators (PWMG0, PWMG1 & PWMG2). Their individual outputs are listed as below:

- PWMG0 – PA0, PB4, PB5
- PWMG1 – PA4, PB6, PB7
- PWMG2 – PA3, PB2, PB3, PA5 (open drain output only)

#### 5.8.1 PWM Waveform

A PWM output waveform (Fig.12) has a time-base ( $T_{\text{Period}} = \text{Time of Period}$ ) and a time with output high level (Duty Cycle). The frequency of the PWM output is the inverse of the period ( $f_{\text{PWM}} = 1/T_{\text{Period}}$ ).

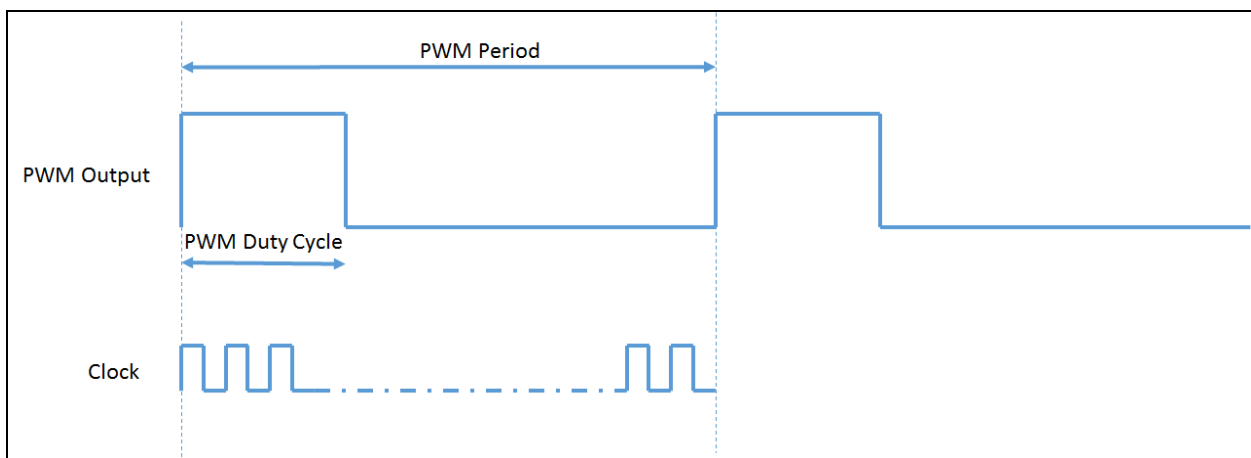

Fig.12: PWM Output Waveform

### 5.8.2 Hardware Diagram

Fig.13 shows the hardware diagram of the whole set of SuLED 11-bit hardware PWM generators. Those three PWM generators use a common Up-Counter and clock source selector to create the time base, and so the start points (the rising edge) of the PWM cycle are synchronized. The clock source can be IHRC or system clock. The PWM signal output pins that can be selected via *pwmgxc* register selection. The period of PWM waveform is defined by the common PWM upper bound high and low registers, and the duty cycle of individual PWM waveform is defined by the individual set in the PWM duty high and low registers.

The additional OR and XOR logic of PWMG0 channel is used to create the complementary switching waveforms with dead zone control. Comparator output can control the PWM waveform by selecting GPC\_PWM code option.

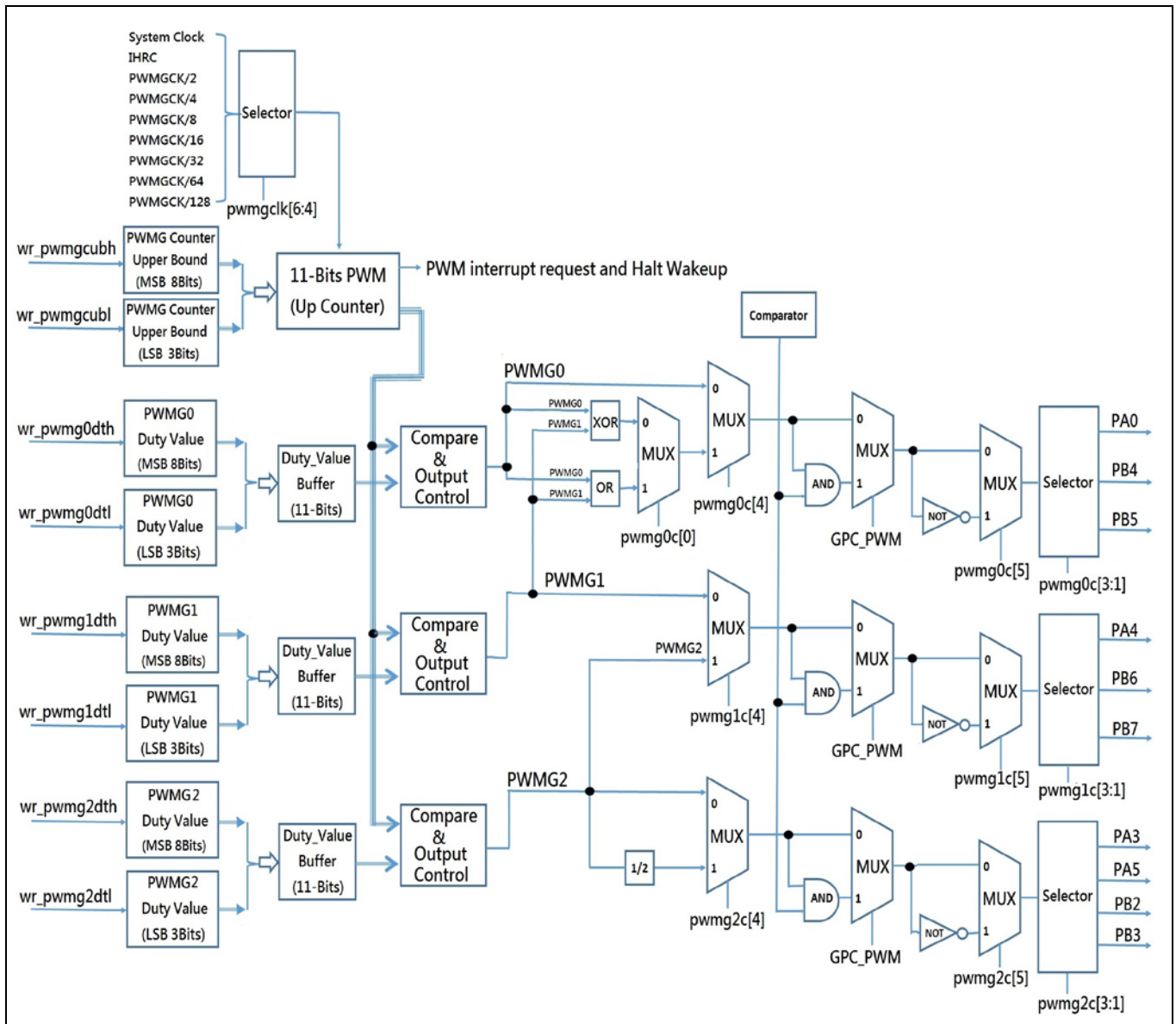

Fig.13: Hardware diagram of whole set of triple SuLED 11-bit PWM generators

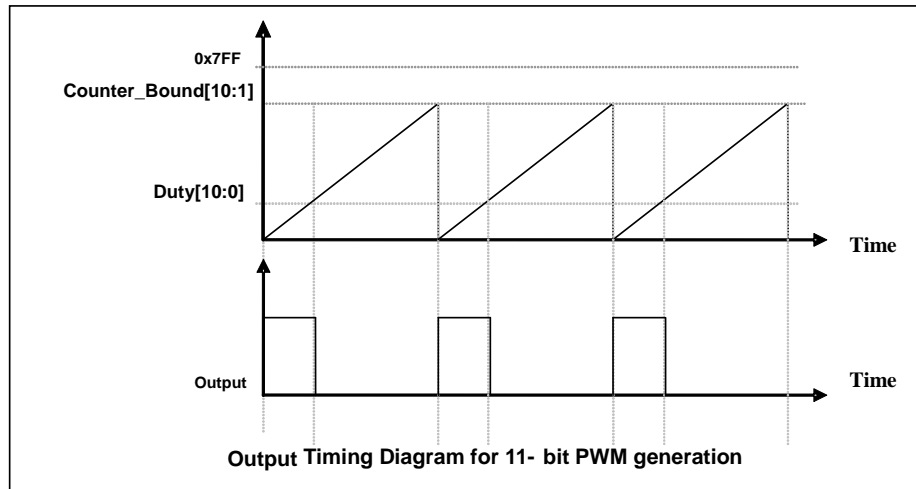

Fig.14: Output Timing Diagram of 11-bit PWM Generator

### 5.8.3 Equations for 11-bit PWM Generator

If  $F_{IHRC}$  is the frequency of IHRC oscillator and IHRC is the chosen clock source for 11-bit PWM generator, the PWM frequency and duty cycle in time will be:

$$\text{Frequency of PWM Output} = F_{IHRC} \div [CB + 1]$$

$$\text{Duty Cycle of PWM Output (in time)} = (1/F_{IHRC}) * [DB10\_1 + DB0 * 0.5 + 0.5]$$

Where, Duty\_Bound[10:1] = {pwmgxdth[7:0],pwmgxdtl[7:6]} = **DB10\_1**; duty bound

Duty\_Bound[0] = pwmgxdtl[5] = **DB0**

Counter\_Bound[10:1] = {pwmgcubh[7:0], pwmgcubl[7:6]} = **CB**; counter bound



### 5.9 WatchDog Timer

The watchdog timer (WDT) is a counter with clock coming from ILRC. WDT can be cleared by power-on-reset or by command ***wdreset*** at any time. There are four different timeout periods of watchdog timer to be chosen by setting the ***misc*** register, it is:

- ◆ 8k ILRC clocks period if register `misc[1:0]=00` (default)
- ◆ 16k ILRC clocks period if register `misc[1:0]=01`
- ◆ 64k ILRC clocks period if register `misc[1:0]=10`
- ◆ 256k ILRC clocks period if register `misc[1:0]=11`

The frequency of ILRC may drift a lot due to the variation of manufacture, supply voltage and temperature; user should reserve guard band for save operation. Besides, the watchdog period will also be shorter than expected after Reset or Wakeup events. It is suggested to clear WDT by `wdreset` command after these events to ensure enough clock periods before WDT timeout.

When WDT is timeout, PMS152 will be reset to restart the program execution. The relative timing diagram of watchdog timer is shown as Fig.15.

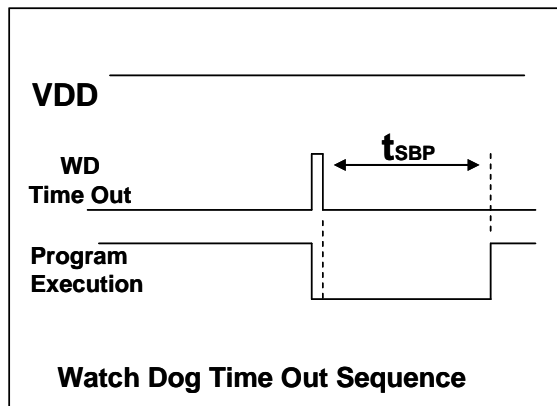

Fig.15: Sequence of Watch Dog Time Out

### 5.10. Interrupt

There are eight interrupt lines for PMS152:

- ◆ External interrupt PA0/PB5
- ◆ External interrupt PB0/PA4
- ◆ Timer16 interrupt
- ◆ GPC interrupt
- ◆ PWMG interrupt
- ◆ Timer2 interrupt

Every interrupt request line has its own corresponding interrupt control bit to enable or disable it; the hardware diagram of interrupt function is shown as Fig.16. All the interrupt request flags are set by hardware and cleared by writing *intrq* register. When the request flags are set, it can be rising edge, falling edge or both, depending on the setting of register *integs*. All the interrupt request lines are also controlled by *engint* instruction (enable global interrupt) to enable interrupt operation and *disgint* instruction (disable global interrupt) to disable it.

The stack memory for interrupt is shared with data memory and its address is specified by stack register *sp*. Since the program counter is 16 bits width, the bit 0 of stack register *sp* should be kept 0. Moreover, user can use *pushaf / popaf* instructions to store or restore the values of *ACC* and *flag* register *to / from* stack memory. Since the stack memory is shared with data memory, the stack position and level are arranged by the compiler in Mini-C project. When defining the stack level in ASM project, users should arrange their locations carefully to prevent address conflicts.

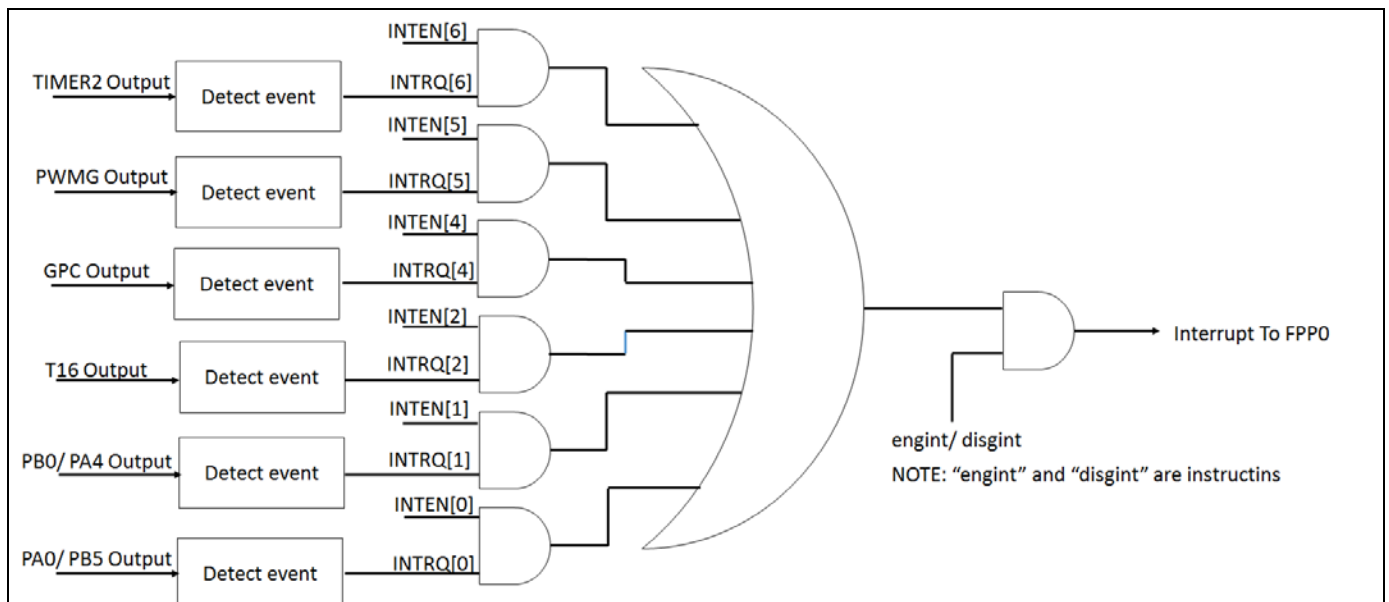

Fig.16: Hardware diagram of interrupt controller

Once the interrupt occurs, its operation will be:

- ◆ The program counter will be stored automatically to the stack memory specified by register *sp*.
- ◆ New *sp* will be updated to *sp+2*.
- ◆ Global interrupt will be disabled automatically.
- ◆ The next instruction will be fetched from address 0x010.

During the interrupt service routine, the interrupt source can be determined by reading the *intrq* register.

Note: Even if INTEN=0, INTRQ will be still triggered by the interrupt source.

After finishing the interrupt service routine and issuing the *reti* instruction to return back, its operation will be:

- ◆ The program counter will be restored automatically from the stack memory specified by register sp.
- ◆ New *sp* will be updated to *sp-2*.
- ◆ Global interrupt will be enabled automatically.
- ◆ The next instruction will be the original one before interrupt.

User must reserve enough stack memory for interrupt, two bytes stack memory for one level interrupt and four bytes for two levels interrupt. And so on, two bytes stack memory is for *pushaf*. For interrupt operation, the following sample program shows how to handle the interrupt, noticing that it needs four bytes stack memory to handle one level interrupt and *pushaf*.

```

void      FPPA0 (void)
{
    ...
    $ INTEN PA0;      // INTEN =1; interrupt request when PA0 level changed
    INTRQ = 0;        // clear INTRQ
    ENGINT            // global interrupt enable
    ...
    DISGINT          // global interrupt disable
    ...
}

void      Interrupt (void) // interrupt service routine
{
    PUSHAF                // store ALU and FLAG register
    If (INTRQ.0)
    {
        // Here for PA0 interrupt service routine
        INTRQ.0 = 0;
        ...
    }
    ...
    POPAF                // restore ALU and FLAG register
}

```

### 5.11 Power-Save and Power-Down

There are three operational modes defined by hardware: ON mode, Power-Save mode and Power-Down modes. ON mode is the state of normal operation with all functions ON, Power-Save mode (“*stopexe*”) is the state to reduce operating current and CPU keeps ready to continue, Power-Down mode (“*stopsys*”) is used to save power deeply. Therefore, Power-Save mode is used in the system which needs low operating power with wake-up occasionally and Power-Down mode is used in the system which needs power down deeply with seldom wake-up. Table 5 shows the differences in oscillator modules between Power-Save mode (“*stopexe*”) and Power-Down mode (“*stopsys*”).

Differences in oscillator modules between STOPSYS and STOPEXE			
	IHRC	ILRC	EOSC
STOPSYS	Stop	Stop	Stop
STOPEXE	No Change	No Change	No Change

Table 5: Differences in oscillator modules between STOPSYS and STOPEXE

#### 5.11.1 Power-Save mode (“*stopexe*”)

Using “*stopexe*” instruction to enter the Power-Save mode, only system clock is disabled, remaining all the oscillator modules active. For CPU, it stops executing; however, for Timer16, counter keep counting if its clock source is not the system clock. Wake-up from input pins can be considered as a continuation of normal execution, the detail information for Power-Save mode shows below:

- IHRC, ILRC and EOSC oscillator modules: No change, keep active if it was enabled.
- System clock: Disable, therefore, CPU stops execution.
- OTP memory is turned off.
- Timer16, Timer2: Stop counting if system clock is selected by clock source or the corresponding oscillator module is disabled; Otherwise, it keeps counting.
- Wake-up sources: IO toggle in digital mode (PxDIER bit is 1) or Timer16 or Timer2 or Timer3.

An example shows how to use Timer16 to wake-up from “*stopexe*”:

```

$ T16M    ILRC, /1, BIT8           // Timer16 setting
...
WORD     count = 0;
STT16    count;
stopexe;
...

```

The initial counting value of Timer16 is zero and the system will be woken up after the Timer16 counts 256 ILRC clocks.

### 5.11.2 Power-Down mode (“*stopsys*”)

Power-Down mode is the state of deeply power-saving with turning off all the oscillator modules. By using the “*stopsys*” instruction, this chip will be put on Power-Down mode directly. The following shows the internal status of PMS152 detail when “*stopsys*” command is issued:

- All the oscillator modules are turned off.
- OTP memory is turned off.
- The contents of SRAM and registers remain unchanged.
- Wake-up sources: IO toggle in digital mode (PxDIER bit is 1)

Wake-up from input pins can be considered as a continuation of normal execution. To minimize power consumption, all the I/O pins should be carefully manipulated before entering power-down mode. The reference sample program for power down is shown as below:

```

CLKMD    =    0xF4;    //    Change clock from IHRC to ILRC
CLKMD.4  =    0;      //    disable IHRC
...
while (1)
{
    STOPSYS;           //    enter power-down
    if (...) break;    //    if wakeup happen and check OK, then return to high speed,
                        //    else stay in power-down mode again
}
CLKMD    =    0x34;    //    Change clock from ILRC to IHRC/2

```

### 5.11.3 Wake-up

After entering the Power-Down or Power-Save modes, the PMS152 can be resumed to normal operation by toggling IO pins. Timer16 and Timer2 interrupt is available for Power-Save mode ONLY. Table 6 shows the differences in wake-up sources between STOPSYS and STOPEXE.

<b>Differences in wake-up sources between STOPSYS and STOPEXE</b>		
	IO Toggle	T16 Interrupt
STOPSYS	Yes	No
STOPEXE	Yes	Yes

Table 6: Differences in wake-up sources between Power-Save mode and Power-Down mode

When using the IO pins to wake-up the PMS152, registers **padier** should be properly set to enable the wake-up function for every corresponding pin. The time for normal wake-up is about 3000 ILRC clocks counting from wake-up event; fast wake-up can be selected to reduce the wake-up time by **misc** register, and the time for fast wake-up is about 45 ILRC clocks from IO toggling.

# PMS152

## 8bit OTP Type SuLED IO Controller

Suspend mode	Wake-up mode	Wake-up time ( $t_{WUP}$ ) from IO toggle
STOPEXE suspend or STOPSYS suspend	Fast wake-up	$45 * T_{ILRC}$ , Where $T_{ILRC}$ is the time period of ILRC
STOPEXE suspend or STOPSYS suspend	Normal wake-up	$3000 * T_{ILRC}$ , Where $T_{ILRC}$ is the clock period of ILRC

Please notice that when Code Option is set to Fast boot-up, no matter which wake-up mode is selected in misc.5, the wake-up mode will be forced to be FAST. If Normal boot-up is selected, the wake-up mode is determined by misc.5.

### 5.12 IO Pins

All the pins can be independently set into two states output or input by configuring the data registers (*pa*, *pb*), control registers (*pac*, *pbpc*) and pull-high registers (*paph*, *pbph*). All these pins have Schmitt-trigger input buffer and output driver with CMOS level. When it is set to output low, the pull-up resistor is turned off automatically. If user wants to read the pin state, please notice that it should be set to input mode before reading the data port; if user reads the data port when it is set to output mode, the reading data comes from data register, NOT from IO pad. As an example, Table 7 shows the configuration table of bit 0 of port A. The hardware diagram of IO buffer is also shown as Fig.17.

<i>pa.0</i>	<i>pac.0</i>	<i>paph.0</i>	Description
X	0	0	Input without pull-up resistor
X	0	1	Input with pull-up resistor
0	1	X	Output low without pull-up resistor
1	1	0	Output high without pull-up resistor
1	1	1	Output high with pull-up resistor

Table 7: PA0 Configuration Table

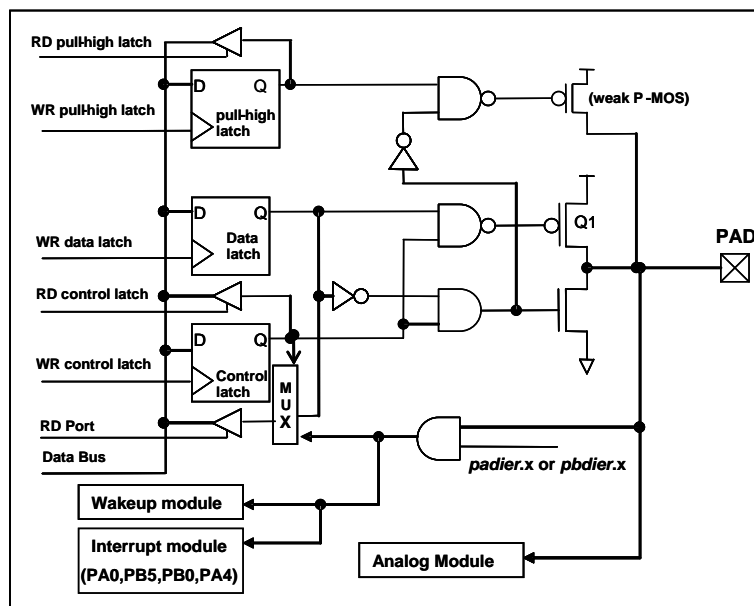

Fig.17: Hardware diagram of IO buffer

Other than PA5, all the IO pins have the same structure; PA5 can be open-drain ONLY when setting to output mode (without Q1). The corresponding bits in registers *padier* / *pbdier* should be set to low to prevent leakage current for those pins are selected to be analog function. When PMS152 is put in power-down or power-save mode, every pin can be used to wake-up system by toggling its state. Therefore, those pins needed to wake-up system must be set to input mode and set the corresponding bits of registers *padier* and *pbdier* to high. The same reason, *padier.0* should be set high when PA0 is used as external interrupt pin, *pbdier.0* for PB0, *padier.4* for PA4 and *pbdier.5* for PB5.

### 5.13 Reset and LVR

#### 5.13.1 Reset

There are many causes to reset the PMS152, once reset is asserted, most of all the registers in PMS152 will be set to default values, system should be restarted once abnormal cases happen, or by jumping program counter to address 0x0. The data memory is in uncertain state when reset comes from power-up and LVR; however, the content will be kept when reset comes from PRSTB pin or WDT timeout.

#### 5.13.2 LVR reset

By code option, there are 8 different levels of LVR for reset ~ 4.5V, 3.5V, 3.0V, 2.75V, 2.5V, 2.2V, 2.0V and 1.8V; usually, user selects LVR reset level to be in conjunction with operating frequency and supply voltage.



### 6. IO Registers

#### 6.1. ACC Status Flag Register (*flag*), IO address = 0x00

Bit	Reset	R/W	Description
7 - 4	-	-	Reserved. Please do not use.
3	0	R/W	OV (Overflow Flag). This bit is set to be 1 whenever the sign operation is overflow.
2	0	R/W	AC (Auxiliary Carry Flag). There are two conditions to set this bit, the first one is carry out of low nibble in addition operation and the other one is borrow from the high nibble into low nibble in subtraction operation.
1	0	R/W	C (Carry Flag). There are two conditions to set this bit, the first one is carry out in addition operation, and the other one is borrow in subtraction operation. Carry is also affected by shift with carry instruction.
0	0	R/W	Z (Zero Flag). This bit will be set when the result of arithmetic or logic operation is zero; Otherwise, it is cleared.

#### 6.2. Stack Pointer Register (*sp*), IO address = 0x02

Bit	Reset	R/W	Description
7 - 0	-	R/W	Stack Pointer Register. Read out the current stack pointer, or write to change the stack pointer.

#### 6.3. Clock Mode Register (*clkmd*), IO address = 0x03

Bit	Reset	R/W	Description		
7 - 5	111	R/W	System clock (CLK) selection:		
			Type 0, clkmd[3]=0	Type 1, clkmd[3]=1	
			<table style="width: 100%; border-collapse: collapse;"> <tr> <td style="width: 50%; vertical-align: top;">           000: IHRC÷4            001: IHRC÷2            010: IHRC            011: EOSC÷4            100: EOSC÷2            101: EOSC            110: ILRC÷4            111: ILRC (default)         </td> <td style="width: 50%; vertical-align: top;">           000: IHRC÷16            001: IHRC÷8            010: ILRC÷16 (ICE does NOT Support.)            011: IHRC÷32            100: IHRC÷64            101: EOSC÷8            11x: reserved         </td> </tr> </table>	000: IHRC÷4 001: IHRC÷2 010: IHRC 011: EOSC÷4 100: EOSC÷2 101: EOSC 110: ILRC÷4 111: ILRC (default)	000: IHRC÷16 001: IHRC÷8 010: ILRC÷16 (ICE does NOT Support.) 011: IHRC÷32 100: IHRC÷64 101: EOSC÷8 11x: reserved
000: IHRC÷4 001: IHRC÷2 010: IHRC 011: EOSC÷4 100: EOSC÷2 101: EOSC 110: ILRC÷4 111: ILRC (default)	000: IHRC÷16 001: IHRC÷8 010: ILRC÷16 (ICE does NOT Support.) 011: IHRC÷32 100: IHRC÷64 101: EOSC÷8 11x: reserved				
4	1	R/W	Internal High RC Enable. 0 / 1: disable / enable		
3	0	R/W	Clock Type Select. This bit is used to select the clock type in bit [7:5]. 0 / 1: Type 0 / Type 1		
2	1	R/W	Internal Low RC Enable. 0 / 1: disable / enable If ILRC is disabled, watchdog timer is also disabled.		
1	1	R/W	Watch Dog Enable. 0 / 1: disable / enable		
0	0	R/W	Pin PA5/PRSTB function. 0 / 1: PA5 / PRSTB		

### 6.4. Interrupt Enable Register (*inten*), IO address = 0x04

Bit	Reset	R/W	Description
7	0	R/W	Reserved
6	0	R/W	Enable interrupt from Timer2. 0 / 1: disable / enable
5	0	R/W	Enable interrupt from PWMG. 0 / 1: disable / enable
4	0	R/W	Enable interrupt from comparator. 0 / 1: disable / enable
3	0	R/W	Reserved
2	0	R/W	Enable interrupt from Timer16 overflow. 0 / 1: disable / enable
1	0	R/W	Enable interrupt from PB0/PA4. 0 / 1: disable / enable
0	0	R/W	Enable interrupt from PA0/PB5. 0 / 1: disable / enable

### 6.5. Interrupt Request Register (*intrq*), IO address = 0x05

Bit	Reset	R/W	Description
7	-	R/W	Reserved
6	-	R/W	Interrupt Request from Timer2, this bit is set by hardware and cleared by software. 0 / 1: No request / Request
5	-	R/W	Interrupt Request from PWMG, this bit is set by hardware and cleared by software. 0 / 1: No request / Request
4	-	R/W	Interrupt Request from comparator, this bit is set by hardware and cleared by software. 0 / 1: No request / Request
3	-	R/W	Reserved
2	-	R/W	Interrupt Request from Timer16, this bit is set by hardware and cleared by software. 0 / 1: No request / Request
1	-	R/W	Interrupt Request from pin PB0/PA4, this bit is set by hardware and cleared by software. 0 / 1: No request / Request
0	-	R/W	Interrupt Request from pin PA0/PB5, this bit is set by hardware and cleared by software. 0 / 1: No Request / request

### 6.6. Timer16 mode Register (*t16m*), IO address = 0x06

Bit	Reset	R/W	Description
7 - 5	000	R/W	Timer16 Clock source selection. 000: disable 001: CLK (system clock) 010: reserved 011: PA4 falling edge (from external pin) 100: IHRC 101: EOSC 110: ILRC 111: PA0 falling edge (from external pin)
4 - 3	00	R/W	Timer16 clock pre-divider. 00: ÷1 01: ÷4 10: ÷16 11: ÷64
2 - 0	000	R/W	Interrupt source selection. Interrupt event happens when the selected bit status is changed. 0 : bit 8 of Timer16 1 : bit 9 of Timer16 2 : bit 10 of Timer16 3 : bit 11 of Timer16 4 : bit 12 of Timer16 5: bit 13 of Timer16 6: bit 14 of Timer16 7: bit 15 of Timer16

### 6.7. MISC Register (*misc*), IO address = 0x08

Bit	Reset	R/W	Description
7 - 6	-	-	Reserved. (keep 0 for future compatibility)
5	0	WO	Enable fast Wake up. Fast wake-up is NOT supported when EOSC is enabled. 0: Normal wake up. The wake-up time is 3000 ILRC clocks (Not for fast boot-up) 1: Fast wake up. The wake-up time is 45 ILRC clocks.
4	-	-	Reserved.
3	-	-	Reserved.
2	0	WO	Disable LVR function. 0 / 1 : Enable / Disable
1 - 0	00	WO	Watch dog time out period 00: 8k ILRC clock period 01: 16k ILRC clock period 10: 64k ILRC clock period 11: 256k ILRC clock period

### 6.8. External Oscillator setting Register (*eoscr*), IO address = 0x0a

Bit	Reset	R/W	Description
7	0	WO	Enable external crystal oscillator. 0 / 1 : Disable / Enable
6 - 5	00	WO	External crystal oscillator selection. 00 : reserved 01 : Low driving capability, for lower frequency, ex: 32KHz crystal oscillator ( <b>reserved</b> ) 10 : Middle driving capability, for middle frequency, ex: 1MHz crystal oscillator 11 : High driving capability, for higher frequency, ex: 4MHz crystal oscillator
4 - 1	-	-	Reserved. Please keep 0 for future compatibility.
0	0	WO	Power-down the Band-gap and LVR hardware modules. 0 / 1: normal / power-down.

### 6.9. Interrupt Edge Select Register (*integs*), IO address = 0x0c

Bit	Reset	R/W	Description
7 - 5	-	-	Reserved.
4	0	WO	Timer16 edge selection. 0 : rising edge of the selected bit to trigger interrupt 1 : falling edge of the selected bit to trigger interrupt
3 - 2	00	WO	PB0/PA4 edge selection. 00: both rising edge and falling edge of the selected bit to trigger interrupt 01: rising edge of the selected bit to trigger interrupt 10: falling edge of the selected bit to trigger interrupt 11: reserved.
1 - 0	00	WO	PA0/PB5 edge selection. 00: both rising edge and falling edge of the selected bit to trigger interrupt 01: rising edge of the selected bit to trigger interrupt 10: falling edge of the selected bit to trigger interrupt 11: reserved.

### 6.10. Port A Digital Input Enable Register (*padier*), IO address = 0x0d

Bit	Reset	R/W	Description
7	1	WO	Enable PA7 digital input and wake-up event. 1 / 0: enable / disable. This bit should be set to low to prevent leakage current when external crystal oscillator is used. If this bit is set to low, PA7 can NOT be used to wake-up the system.
6	1	WO	Enable PA6 digital input and wake-up event. 1 / 0: enable / disable. This bit should be set to low to prevent leakage current when external crystal oscillator is used. If this bit is set to low, PA6 can NOT be used to wake-up the system.
5	1	WO	Enable PA5 digital input and wake-up event. 1 / 0: enable / disable. This bit can be set to low to disable wake-up from PA5 toggling.
4	1	WO	Enable PA4 digital input and wake-up event. 1 / 0: enable / disable. This bit should be set to low when PA4 is assigned as comparator input to prevent leakage current. If this bit is set to low, PA4 can NOT be used to wake-up the system.
3	1	WO	Enable PA3 digital input and wake-up event. 1 / 0: enable / disable. This bit should be set to low when PA3 is assigned as comparator input to prevent leakage current. If this bit is set to low, PA3 can NOT be used to wake-up the system.
2 - 1	1	WO	Reserved
0	1	WO	Enable PA0 digital input and wake-up event and interrupt request. 1 / 0: enable / disable. This bit can be set to low to disable wake-up from PA0 toggling and interrupt request from this pin.

### 6.11. Port B Digital Input Enable Register (*pbdir*), IO address = 0x0e

Bit	Reset	R/W	Description
7 - 0	0xFF	WO	Enable PB7~PB0 digital input and wake-up event. 1 / 0: enable / disable. The bit should be set to low when the pad is assigned as comparator input to prevent leakage current. If the bit is set to low, the pad can NOT be used to wake-up the system.

### 6.12. Port A Data Register (*pa*), IO address = 0x10

Bit	Reset	R/W	Description
7 - 0	0x00	R/W	Data register for Port A.

### 6.13. Port A Control Register (*pac*), IO address = 0x11

Bit	Reset	R/W	Description
7 - 0	0x00	R/W	Port A control registers. This register is used to define input mode or output mode for each corresponding pin of port A. 0 / 1: input / output Please note : PA5 is an open drain output.

### 6.14. Port A Pull-High Register (*paph*), IO address = 0x12

Bit	Reset	R/W	Description
7 - 0	0x00	R/W	Port A pull-high register. This register is used to enable the internal pull-high device on each corresponding pin of port A and this pull high function is active only for input mode. 0 / 1 : disable / enable

### 6.15. Port B Data Register (*pb*), IO address = 0x14

Bit	Reset	R/W	Description
7 - 0	0x00	R/W	Data register for Port B.

### 6.16. Port B Control Register (*pbcr*), IO address = 0x15

Bit	Reset	R/W	Description
7 - 0	0x00	R/W	Port B control register. This register is used to define input mode or output mode for each corresponding pin of port B. 0 / 1: input / output

### 6.17. Port B Pull-High Register (*pbph*), IO address = 0x16

Bit	Reset	R/W	Description
7 - 0	0x00	R/W	Port B pull-high register. This register is used to enable the internal pull-high device on each corresponding pin of port B and this pull high function is active only for input mode. 0 / 1 : disable / enable

### 6.18. Comparator Control Register (*gpcc*), IO address = 0x18

Bit	Reset	R/W	Description
7	0	R/W	Enable comparator. 0 / 1 : disable / enable When this bit is set to enable, please also set the corresponding analog input pins to be digital disable to prevent IO leakage.
6	-	RO	Comparator result of comparator. 0: plus input < minus input 1: plus input > minus input
5	0	R/W	Select whether the comparator result output will be sampled by TM2_CLK? 0: result output NOT sampled by TM2_CLK 1: result output sampled by TM2_CLK
4	0	R/W	Inverse the polarity of result output of comparator. 0: polarity is NOT inverted. 1: polarity is inverted.
3 - 1	000	R/W	Selection the minus input (-) of comparator. 000 : PA3 001 : PA4 010 : Internal 1.20 volt band-gap reference voltage 011 : $V_{internal R}$ 100 : PB6 (not for EV5) 101 : PB7 (not for EV5) 11X: reserved
0	0	R/W	Selection the plus input (+) of comparator. 0 : $V_{internal R}$ 1 : PA4

### 6.19. Comparator Selection Register (*gps*), IO address = 0x19

Bit	Reset	R/W	Description
7	0	WO	Comparator output enable (to PA0). 0 / 1 : disable / enable (Please avoid this situation: GPCS will affect the PA3 output function when selecting output to PA0 output in ICE.)
6	0	-	Reserved
5	0	WO	Selection of high range of comparator.
4	0	WO	Selection of low range of comparator.
3 - 0	0000	WO	Selection the voltage level of comparator. 0000 (lowest) ~ 1111 (highest)

### 6.20. Timer2 Control Register (*tm2c*), IO address = 0x1c

Bit	Reset	R/W	Description
7 - 4	0000	R/W	Timer2 clock selection. 0000 : disable 0001 : CLK (system clock) 0010 : IHRC or IHRC *2 (by code option TM2_source) (ICE doesn't support IHRC *2.) 0011 : EOSC 0100 : ILRC 0101 : comparator output 011x : reserved 1000 : PA0 (rising edge) 1001 : ~PA0 (falling edge) 1010 : PB0 (rising edge) 1011 : ~PB0 (falling edge) 1100 : PA4 (rising edge) 1101 : ~PA4 (falling edge) <b>Notice:</b> In ICE mode and IHRC is selected for Timer2 clock, <u>the clock sent to Timer2 does NOT be stopped, Timer2 will keep counting when ICE is in halt state.</u>
3 - 2	00	R/W	Timer2 output selection. 00 : disable 01 : PB2 10 : PA3 11 : PB4
1	0	R/W	TM2 Mode 0: Period Mode 1: PWM Mode
0	0	R/W	Inverse the polarity of result output of TM2. 0: polarity is NOT inverted. 1: polarity is inverted.

### 6.21. Timer2 Scalar Register (*tm2s*), IO address = 0x17

Bit	Reset	R/W	Description
7	0	WO	PWM resolution selection. 0 : 8-bit 1 : 6-bit or 7-bit (by code option TM2_bit) (ICE doesn't support 7-bit.)
6 - 5	00	WO	Timer2 clock pre-scalar. 00 : ÷ 1 01 : ÷ 4 10 : ÷ 16 11 : ÷ 64
4 - 0	00000	WO	Timer2 clock scalar.

### 6.22. Timer2 Counter Register (*tm2ct*), IO address = 0x1d

Bit	Reset	R/W	Description
7 - 0	0x00	R/W	Bit [7:0] of Timer2 counter register.

### 6.23. Timer2 Bound Register (*tm2b*), IO address = 0x09

Bit	Reset	R/W	Description
7 - 0	0x00	WO	Timer2 bound register.

### 6.24. PWMG0 control Register (*pwmg0c*), IO address = 0x20

Bit	Reset	R/W	Description
7	-	-	Reserved.
6	-	RO	Output status of PWMG0 generator.
5	0	WO	Enable to inverse the polarity of PWMG0 generator output. 0 / 1: disable / enable.
4	0	WO	PWMG0 output selection. 0: PWMG0 Output 1: PWMG0 XOR PWMG1 or PWMG0 OR PWMG1 (by <i>pwmg0c.0</i> )
3 - 1	000	R/W	PWMG0 Output Port Selection 000: PWMG0 Output Disable 001: PWMG0 Output to PB5 010: Reserved 011: PWMG0 Output to PA0 100: PWMG0 Output to PB4 1xx: Reserved
0	0	R/W	PWMG0 output pre- selection. 0: PWMG0 XOR PWMG1 1: PWMG0 OR PWMG1



### 6.25. PWMG Clock Register (*pwmgclk*), IO address = 0x21

Bit	Reset	R/W	Description
7	0	WO	PWMG Disable/ Enable 0: PWMG Disable 1: PWMG Enable
6 - 4	000	WO	PWMG clock pre-scalar. 000: ÷1 001: ÷2 010: ÷4 011: ÷8 100: ÷16 101: ÷32 110: ÷64 111: ÷128
3 - 1	-	-	Reserved
0	0	WO	PWMG clock source selection 0: System Clock 1: IHRC or IHRC*2 (by code option PWM_Source)

### 6.26. PWMG0 Duty Value High Register (*pwmg0dth*), IO address = 0x22

Bit	Reset	R/W	Description
7 - 0	-	WO	Bit[10:3] of PWMG0 Duty.

### 6.27. PWMG0 Duty Value Low Register (*pwmg0dtl*), IO address = 0x23

Bit	Reset	R/W	Description
7 - 5	-	WO	Bit[2:0] of PWMG0 Duty.
4 - 0	-	-	Reserved

Note: It's necessary to write PWMG0 Duty\_Value Low Register before writing PWMG0 Duty\_Value High Register.

### 6.28. PWMG Counter Upper Bound High Register (*pwmg cubh*), IO address = 0x24

Bit	Reset	R/W	Description
7 - 0	-	WO	Bit[10:3] of PWMG Counter Bound.

### 6.29. PWMG Counter Upper Bound Low Register (*pwmg cubl*), IO address = 0x25

Bit	Reset	R/W	Description
7 - 5	-	WO	Bit[2:0] of PWMG Counter Bound.
4 - 0	-	-	Reserved

### 6.30. PWMG1 control Register (*pwmg1c*), IO address = 0x26

Bit	Reset	R/W	Description
7	-	-	Reserved
6	-	RO	Output status of PWMG1 generator
5	0	R/W	Enable to inverse the polarity of PWMG1 generator output. 0 / 1: disable / enable.
4	0	R/W	PWMG1 output selection: 0: PWMG1 1: PWMG2
3 - 1	000	R/W	PWMG1 Output Port Selection: 000: PWMG1 Output Disable 001: PWMG1 Output to PB6 010: Reserved 011: PWMG0 Output to PA4 100: PWMG0 Output to PB7 1xx: Reserved
0	-	R/W	Reserved

### 6.31. PWMG1 Duty Value High Register (*pwmg1dth*), IO address = 0x28

Bit	Reset	R/W	Description
7 - 0	-	WO	Bit[10:3] of PWMG1 Duty

### 6.32. PWMG1 Duty Value Low Register (*pwmg1dtl*), IO address = 0x29

Bit	Reset	R/W	Description
7 - 5	-	WO	Bit[2:0] of PWMG1 Duty.
4 - 0	-	-	Reserved

**Note:** It's necessary to write PWMG1 Duty\_Value Low Register before writing PWMG1 Duty\_Value High Register.

### 6.33. PWMG2 control Register (*pwmg2c*), IO address = 0x2C

Bit	Reset	R/W	Description
7	-	-	Reserved.
6	-	RO	Output status of PWMG2 generator.
5	0	R/W	Enable to inverse the polarity of PWMG2 generator output. 0 / 1: disable / enable.
4	0	R/W	PWMG2 output selection: 0: PWMG2 1: PWMG2 ÷2
3 - 1	000	R/W	PWMG2 Output Port Selection: 000: PWMG2 Output Disable 001: PWMG2 Output to PB3 010: Reserved 011: PWMG2 Output to PA3 100: PWMG2 Output to PB2 101: PWMG2 Output to PA5 1xx: Reserved
0	-	R/W	Reserved

### 6.34. PWMG2 Duty Value High Register (*pwmg2dth*), IO address = 0x2E

Bit	Reset	R/W	Description
7 - 0	-	WO	Bit[10:3] of PWMG2 Duty

### 6.35. PWMG2 Duty Value Low Register (*pwmg2dtl*), IO address = 0x2F

Bit	Reset	R/W	Description
7 - 5	-	WO	Bit[2:0] of PWMG2 Duty
4 - 0	-	-	Reserved

Note: It's necessary to write PWMG2 Duty\_Value Low Register before writing PWMG2 Duty\_Value High Register.

### 7. Instructions

Symbol	Description
<b>ACC</b>	Accumulator (Abbreviation of accumulator)
<b>a</b>	Accumulator (symbol of accumulator in program)
<b>sp</b>	Stack pointer
<b>flag</b>	ACC status flag register
<b>I</b>	Immediate data
<b>&amp;</b>	Logical AND
<b> </b>	Logical OR
<b>←</b>	Movement
<b>^</b>	Exclusive logic OR
<b>+</b>	Add
<b>−</b>	Subtraction
<b>~</b>	NOT (logical complement, 1's complement)
<b>¯</b>	NEG (2's complement)
<b>OV</b>	Overflow (The operational result is out of range in signed 2's complement number system)
<b>Z</b>	Zero (If the result of ALU operation is zero, this bit is set to 1)
<b>C</b>	Carry (The operational result is to have carry out for addition or to borrow carry for subtraction in unsigned number system)
<b>AC</b>	Auxiliary Carry  (If there is a carry out from low nibble after the result of ALU operation, this bit is set to 1)
<b>M.n</b>	Only addressed in 0~0x3F (0~63) is allowed
<b>IO.n</b>	Only addressed in 0~0x3F (0~63) is allowed

### 7.1. Data Transfer Instructions

<i>mov</i> a, l	<p>Move immediate data into ACC.  Example: <i>mov</i> a, 0x0f;  Result: a ← 0fh;  Affected flags: 『N』 Z 『N』 C 『N』 AC 『N』 OV</p>
<i>mov</i> M, a	<p>Move data from ACC into memory  Example: <i>mov</i> MEM, a;  Result: MEM ← a  Affected flags: 『N』 Z 『N』 C 『N』 AC 『N』 OV</p>
<i>mov</i> a, M	<p>Move data from memory into ACC  Example: <i>mov</i> a, MEM ;  Result: a ← MEM; Flag Z is set when MEM is zero.  Affected flags: 『Y』 Z 『N』 C 『N』 AC 『N』 OV</p>
<i>mov</i> a, IO	<p>Move data from IO into ACC  Example: <i>mov</i> a, pa ;  Result: a ← pa; Flag Z is set when pa is zero.  Affected flags: 『Y』 Z 『N』 C 『N』 AC 『N』 OV</p>
<i>mov</i> IO, a	<p>Move data from ACC into IO  Example: <i>mov</i> pb, a;  Result: pb ← a  Affected flags: 『N』 Z 『N』 C 『N』 AC 『N』 OV</p>
<i>ldt16</i> word	<p>Move 16-bit counting values in Timer16 to memory in word.  Example: <i>ldt16</i> word;  Result: word ← 16-bit timer  Affected flags: 『N』 Z 『N』 C 『N』 AC 『N』 OV</p> <p>Application Example:</p> <hr style="border-top: 1px dashed black;"/> <pre> word    T16val ;           // declare a RAM word ... clear   lb@ T16val ;       // clear T16val (LSB) clear   hb@ T16val ;       // clear T16val (MSB) stt16   T16val ;           // initial T16 with 0 ... set1    t16m.5 ;           // enable Timer16 ... set0    t16m.5 ;           // disable Timer 16 ldt16   T16val ;           // save the T16 counting value to T16val .... </pre> <hr style="border-top: 1px dashed black;"/>

<i>stt16</i> word	<p>Store 16-bit data from memory in word to Timer16.  Example: <i>stt16</i> word;  Result: 16-bit timer ← word  Affected flags: 『N』 Z 『N』 C 『N』 AC 『N』 OV  Application Example:</p> <hr style="border-top: 1px dashed black;"/> <pre style="margin: 0;">word    T16val ;           // declare a RAM word ... mov     a, 0x34 ; mov     lb@ T16val , a ; // move 0x34 to T16val (LSB) mov     a, 0x12 ; mov     hb@ T16val , a ; // move 0x12 to T16val (MSB) stt16   T16val ;           // initial T16 with 0x1234 ...</pre> <hr style="border-top: 1px dashed black;"/>
<i>idxm</i> a, index	<p>Move data from specified memory to ACC by indirect method. It needs 2T to execute this instruction.  Example: <i>idxm</i> a, index;  Result: a ← [index], where index is declared by word.  Affected flags: 『N』 Z 『N』 C 『N』 AC 『N』 OV  Application Example:</p> <hr style="border-top: 1px dashed black;"/> <pre style="margin: 0;">word    RAMIndex ;         // declare a RAM pointer ... mov     a, 0x5B ;           // assign pointer to an address (LSB) mov     lb@RAMIndex, a ; // save pointer to RAM (LSB) mov     a, 0x00 ;           // assign 0x00 to an address (MSB), should be 0 mov     hb@RAMIndex, a ; // save pointer to RAM (MSB) ... idxm    a, RAMIndex ;      // mov memory data in address 0x5B to ACC</pre> <hr style="border-top: 1px dashed black;"/>

<i>idxm</i> index, a	<p>Move data from ACC to specified memory by indirect method. It needs 2T to execute this instruction.</p> <p>Example: <i>idxm</i> index, a;</p> <p>Result: [index] ← a; where index is declared by word.</p> <p>Affected flags: 『N』 Z 『N』 C 『N』 AC 『N』 OV</p> <p>Application Example:</p> <pre>----- word    RAMIndex ;           // declare a RAM pointer ... mov     a, 0x5B ;           // assign pointer to an address (LSB) mov     lb@RAMIndex, a ;    // save pointer to RAM (LSB) mov     a, 0x00 ;           // assign 0x00 to an address (MSB), should be 0 mov     hb@RAMIndex, a ;    // save pointer to RAM (MSB) ... mov     a, 0xA5 ; idxm    RAMIndex, a ;       // mov 0xA5 to memory in address 0x5B -----</pre>
<i>xch</i> M	<p>Exchange data between ACC and memory</p> <p>Example: <i>xch</i> MEM ;</p> <p>Result: MEM ← a , a ← MEM</p> <p>Affected flags: 『N』 Z 『N』 C 『N』 AC 『N』 OV</p>
<i>pushaf</i>	<p>Move the ACC and flag register to memory that address specified in the stack pointer.</p> <p>Example: <i>pushaf</i>;</p> <p>Result: [sp] ← {flag, ACC}; sp ← sp + 2 ;</p> <p>Affected flags: 『N』 Z 『N』 C 『N』 AC 『N』 OV</p> <p>Application Example:</p> <pre>----- .romadr 0x10 ;               // ISR entry address pushaf ;                    // put ACC and flag into stack memory ...                          // ISR program ...                          // ISR program popaf ;                      // restore ACC and flag from stack memory reti ; -----</pre>
<i>popaf</i>	<p>Restore ACC and flag from the memory which address is specified in the stack pointer.</p> <p>Example: <i>popaf</i>;</p> <p>Result: sp ← sp - 2 ; {Flag, ACC} ← [sp] ;</p> <p>Affected flags: 『Y』 Z 『Y』 C 『Y』 AC 『Y』 OV</p>

### 7.2. Arithmetic Operation Instructions

<i>add</i> a, I	<p>Add immediate data with ACC, then put result into ACC</p> <p>Example: <i>add</i> a, 0x0f ;</p> <p>Result: <math>a \leftarrow a + 0fh</math></p> <p>Affected flags: 『Y』 Z 『Y』 C 『Y』 AC 『Y』 OV</p>
<i>add</i> a, M	<p>Add data in memory with ACC, then put result into ACC</p> <p>Example: <i>add</i> a, MEM ;</p> <p>Result: <math>a \leftarrow a + MEM</math></p> <p>Affected flags: 『Y』 Z 『Y』 C 『Y』 AC 『Y』 OV</p>
<i>add</i> M, a	<p>Add data in memory with ACC, then put result into memory</p> <p>Example: <i>add</i> MEM, a ;</p> <p>Result: <math>MEM \leftarrow a + MEM</math></p> <p>Affected flags: 『Y』 Z 『Y』 C 『Y』 AC 『Y』 OV</p>
<i>addc</i> a, M	<p>Add data in memory with ACC and carry bit, then put result into ACC</p> <p>Example: <i>addc</i> a, MEM ;</p> <p>Result: <math>a \leftarrow a + MEM + C</math></p> <p>Affected flags: 『Y』 Z 『Y』 C 『Y』 AC 『Y』 OV</p>
<i>addc</i> M, a	<p>Add data in memory with ACC and carry bit, then put result into memory</p> <p>Example: <i>addc</i> MEM, a ;</p> <p>Result: <math>MEM \leftarrow a + MEM + C</math></p> <p>Affected flags: 『Y』 Z 『Y』 C 『Y』 AC 『Y』 OV</p>
<i>addc</i> a	<p>Add carry with ACC, then put result into ACC</p> <p>Example: <i>addc</i> a ;</p> <p>Result: <math>a \leftarrow a + C</math></p> <p>Affected flags: 『Y』 Z 『Y』 C 『Y』 AC 『Y』 OV</p>
<i>addc</i> M	<p>Add carry with memory, then put result into memory</p> <p>Example: <i>addc</i> MEM ;</p> <p>Result: <math>MEM \leftarrow MEM + C</math></p> <p>Affected flags: 『Y』 Z 『Y』 C 『Y』 AC 『Y』 OV</p>
<i>nadd</i> a, M	<p>Add negative logic (2's complement) of ACC with memory</p> <p>Example: <i>nadd</i> a, MEM ;</p> <p>Result: <math>a \leftarrow \overline{a} + MEM</math></p> <p>Affected flags: 『Y』 Z 『Y』 C 『Y』 AC 『Y』 OV</p>
<i>nadd</i> M, a	<p>Add negative logic (2's complement) of memory with ACC</p> <p>Example: <i>nadd</i> MEM, a ;</p> <p>Result: <math>MEM \leftarrow \overline{MEM} + a</math></p> <p>Affected flags: 『Y』 Z 『Y』 C 『Y』 AC 『Y』 OV</p>
<i>sub</i> a, I	<p>Subtraction immediate data from ACC, then put result into ACC.</p> <p>Example: <i>sub</i> a, 0x0f ;</p> <p>Result: <math>a \leftarrow a - 0fh</math> ( <math>a + [2's \text{ complement of } 0fh]</math> )</p> <p>Affected flags: 『Y』 Z 『Y』 C 『Y』 AC 『Y』 OV</p>
<i>sub</i> a, M	<p>Subtraction data in memory from ACC, then put result into ACC</p> <p>Example: <i>sub</i> a, MEM ;</p> <p>Result: <math>a \leftarrow a - MEM</math> ( <math>a + [2's \text{ complement of } M]</math> )</p> <p>Affected flags: 『Y』 Z 『Y』 C 『Y』 AC 『Y』 OV</p>



<i>sub</i> M, a	<p>Subtraction data in ACC from memory, then put result into memory</p> <p>Example: <i>sub</i> MEM, a;</p> <p>Result: <math>MEM \leftarrow MEM - a</math> ( <math>MEM + [2\text{'s complement of } a]</math> )</p> <p>Affected flags: 『Y』 Z 『Y』 C 『Y』 AC 『Y』 OV</p>
<i>subc</i> a, M	<p>Subtraction data in memory and carry from ACC, then put result into ACC</p> <p>Example: <i>subc</i> a, MEM;</p> <p>Result: <math>a \leftarrow a - MEM - C</math></p> <p>Affected flags: 『Y』 Z 『Y』 C 『Y』 AC 『Y』 OV</p>
<i>subc</i> M, a	<p>Subtraction ACC and carry bit from memory, then put result into memory</p> <p>Example: <i>subc</i> MEM, a ;</p> <p>Result: <math>MEM \leftarrow MEM - a - C</math></p> <p>Affected flags: 『Y』 Z 『Y』 C 『Y』 AC 『Y』 OV</p>
<i>subc</i> a	<p>Subtraction carry from ACC, then put result into ACC</p> <p>Example: <i>subc</i> a;</p> <p>Result: <math>a \leftarrow a - C</math></p> <p>Affected flags: 『Y』 Z 『Y』 C 『Y』 AC 『Y』 OV</p>
<i>subc</i> M	<p>Subtraction carry from the content of memory, then put result into memory</p> <p>Example: <i>subc</i> MEM;</p> <p>Result: <math>MEM \leftarrow MEM - C</math></p> <p>Affected flags: 『Y』 Z 『Y』 C 『Y』 AC 『Y』 OV</p>
<i>inc</i> M	<p>Increment the content of memory</p> <p>Example: <i>inc</i> MEM ;</p> <p>Result: <math>MEM \leftarrow MEM + 1</math></p> <p>Affected flags: 『Y』 Z 『Y』 C 『Y』 AC 『Y』 OV</p>
<i>dec</i> M	<p>Decrement the content of memory</p> <p>Example: <i>dec</i> MEM;</p> <p>Result: <math>MEM \leftarrow MEM - 1</math></p> <p>Affected flags: 『Y』 Z 『Y』 C 『Y』 AC 『Y』 OV</p>
<i>clear</i> M	<p>Clear the content of memory</p> <p>Example: <i>clear</i> MEM ;</p> <p>Result: <math>MEM \leftarrow 0</math></p> <p>Affected flags: 『N』 Z 『N』 C 『N』 AC 『N』 OV</p>

### 7.3. Shift Operation Instructions

<i>sr a</i>	Shift right of ACC, shift 0 to bit 7 Example: <i>sr a</i> ; Result: $a(0, b7, b6, b5, b4, b3, b2, b1) \leftarrow a(b7, b6, b5, b4, b3, b2, b1, b0)$ , $C \leftarrow a(b0)$ Affected flags: 『N』 Z 『Y』 C 『N』 AC 『N』 OV
<i>src a</i>	Shift right of ACC with carry bit 7 to flag Example: <i>src a</i> ; Result: $a(c, b7, b6, b5, b4, b3, b2, b1) \leftarrow a(b7, b6, b5, b4, b3, b2, b1, b0)$ , $C \leftarrow a(b0)$ Affected flags: 『N』 Z 『Y』 C 『N』 AC 『N』 OV
<i>sr M</i>	Shift right the content of memory, shift 0 to bit 7 Example: <i>sr MEM</i> ; Result: $MEM(0, b7, b6, b5, b4, b3, b2, b1) \leftarrow MEM(b7, b6, b5, b4, b3, b2, b1, b0)$ , $C \leftarrow MEM(b0)$ Affected flags: 『N』 Z 『Y』 C 『N』 AC 『N』 OV
<i>src M</i>	Shift right of memory with carry bit 7 to flag Example: <i>src MEM</i> ; Result: $MEM(c, b7, b6, b5, b4, b3, b2, b1) \leftarrow MEM(b7, b6, b5, b4, b3, b2, b1, b0)$ , $C \leftarrow MEM(b0)$ Affected flags: 『N』 Z 『Y』 C 『N』 AC 『N』 OV
<i>sl a</i>	Shift left of ACC shift 0 to bit 0 Example: <i>sl a</i> ; Result: $a(b6, b5, b4, b3, b2, b1, b0, 0) \leftarrow a(b7, b6, b5, b4, b3, b2, b1, b0)$ , $C \leftarrow a(b7)$ Affected flags: 『N』 Z 『Y』 C 『N』 AC 『N』 OV
<i>slc a</i>	Shift left of ACC with carry bit 0 to flag Example: <i>slc a</i> ; Result: $a(b6, b5, b4, b3, b2, b1, b0, c) \leftarrow a(b7, b6, b5, b4, b3, b2, b1, b0)$ , $C \leftarrow a(b7)$ Affected flags: 『N』 Z 『Y』 C 『N』 AC 『N』 OV
<i>sl M</i>	Shift left of memory, shift 0 to bit 0 Example: <i>sl MEM</i> ; Result: $MEM(b6, b5, b4, b3, b2, b1, b0, 0) \leftarrow MEM(b7, b6, b5, b4, b3, b2, b1, b0)$ , $C \leftarrow MEM(b7)$ Affected flags: 『N』 Z 『Y』 C 『N』 AC 『N』 OV
<i>slc M</i>	Shift left of memory with carry bit 0 to flag Example: <i>slc MEM</i> ; Result: $MEM(b6, b5, b4, b3, b2, b1, b0, C) \leftarrow MEM(b7, b6, b5, b4, b3, b2, b1, b0)$ , $C \leftarrow MEM(b7)$ Affected flags: 『N』 Z 『Y』 C 『N』 AC 『N』 OV
<i>swap a</i>	Swap the high nibble and low nibble of ACC Example: <i>swap a</i> ; Result: $a(b3, b2, b1, b0, b7, b6, b5, b4) \leftarrow a(b7, b6, b5, b4, b3, b2, b1, b0)$ Affected flags: 『N』 Z 『N』 C 『N』 AC 『N』 OV

### 7.4. Logic Operation Instructions

<i>and</i> a, l	Perform logic AND on ACC and immediate data, then put result into ACC Example: <i>and</i> a, 0x0f ; Result: $a \leftarrow a \& 0fh$ Affected flags: 『Y』 Z 『N』 C 『N』 AC 『N』 OV
<i>and</i> a, M	Perform logic AND on ACC and memory, then put result into ACC Example: <i>and</i> a, RAM10 ; Result: $a \leftarrow a \& RAM10$ Affected flags: 『Y』 Z 『N』 C 『N』 AC 『N』 OV
<i>and</i> M, a	Perform logic AND on ACC and memory, then put result into memory Example: <i>and</i> MEM, a ; Result: $MEM \leftarrow a \& MEM$ Affected flags: 『Y』 Z 『N』 C 『N』 AC 『N』 OV
<i>or</i> a, l	Perform logic OR on ACC and immediate data, then put result into ACC Example: <i>or</i> a, 0x0f ; Result: $a \leftarrow a   0fh$ Affected flags: 『Y』 Z 『N』 C 『N』 AC 『N』 OV
<i>or</i> a, M	Perform logic OR on ACC and memory, then put result into ACC Example: <i>or</i> a, MEM ; Result: $a \leftarrow a   MEM$ Affected flags: 『Y』 Z 『N』 C 『N』 AC 『N』 OV
<i>or</i> M, a	Perform logic OR on ACC and memory, then put result into memory Example: <i>or</i> MEM, a ; Result: $MEM \leftarrow a   MEM$ Affected flags: 『Y』 Z 『N』 C 『N』 AC 『N』 OV
<i>xor</i> a, l	Perform logic XOR on ACC and immediate data, then put result into ACC Example: <i>xor</i> a, 0x0f ; Result: $a \leftarrow a \wedge 0fh$ Affected flags: 『Y』 Z 『N』 C 『N』 AC 『N』 OV
<i>xor</i> IO, a	Perform logic XOR on ACC and IO register, then put result into IO register Example: <i>xor</i> pa, a ; Result: $pa \leftarrow a \wedge pa$ ; // pa is the data register of port A Affected flags: 『N』 Z 『N』 C 『N』 AC 『N』 OV
<i>xor</i> a, M	Perform logic XOR on ACC and memory, then put result into ACC Example: <i>xor</i> a, MEM ; Result: $a \leftarrow a \wedge RAM10$ Affected flags: 『Y』 Z 『N』 C 『N』 AC 『N』 OV
<i>xor</i> M, a	Perform logic XOR on ACC and memory, then put result into memory Example: <i>xor</i> MEM, a ; Result: $MEM \leftarrow a \wedge MEM$ Affected flags: 『Y』 Z 『N』 C 『N』 AC 『N』 OV

<i>not</i> a	<p>Perform 1's complement (logical complement) of ACC  Example: <i>not</i> a ;  Result: a ← ~a  Affected flags: 『Y』 Z 『N』 C 『N』 AC 『N』 OV  Application Example:</p> <hr style="border-top: 1px dashed black;"/> <pre style="margin-left: 40px;"> mov    a, 0x38 ;    // ACC=0X38 not    a ;          // ACC=0XC7 </pre> <hr style="border-top: 1px dashed black;"/>
<i>not</i> M	<p>Perform 1's complement (logical complement) of memory  Example: <i>not</i> MEM ;  Result: MEM ← ~MEM  Affected flags: 『Y』 Z 『N』 C 『N』 AC 『N』 OV  Application Example:</p> <hr style="border-top: 1px dashed black;"/> <pre style="margin-left: 40px;"> mov    a, 0x38 ; mov    mem, a ;    // mem = 0x38 not    mem ;      // mem = 0xC7 </pre> <hr style="border-top: 1px dashed black;"/>
<i>neg</i> a	<p>Perform 2's complement of ACC  Example: <i>neg</i> a ;  Result: a ← <math>\overline{a}</math>  Affected flags: 『Y』 Z 『N』 C 『N』 AC 『N』 OV  Application Example:</p> <hr style="border-top: 1px dashed black;"/> <pre style="margin-left: 40px;"> mov    a, 0x38 ;    // ACC=0X38 neg    a ;          // ACC=0XC8 </pre> <hr style="border-top: 1px dashed black;"/>
<i>neg</i> M	<p>Perform 2's complement of memory  Example: <i>neg</i> MEM ;  Result: MEM ← <math>\overline{MEM}</math>  Affected flags: 『Y』 Z 『N』 C 『N』 AC 『N』 OV  Application Example:</p> <hr style="border-top: 1px dashed black;"/> <pre style="margin-left: 40px;"> mov    a, 0x38 ; mov    mem, a ;    // mem = 0x38 not    mem ;      // mem = 0xC8 </pre> <hr style="border-top: 1px dashed black;"/>

<i>comp</i> a, M	<p>Compare ACC with the content of memory</p> <p>Example: <b><i>comp a, MEM;</i></b></p> <p>Result: Flag will be changed by regarding as ( a - MEM )</p> <p>Affected flags: 『Y』 Z 『Y』 C 『Y』 AC 『Y』 OV</p> <p>Application Example:</p> <hr style="border-top: 1px dashed black;"/> <pre style="margin-left: 40px;"> <b>mov</b>    a, 0x38 ; <b>mov</b>    mem, a ; <b>comp</b>   a, mem ; // Z flag is set as 1 <b>mov</b>    a, 0x42 ; <b>mov</b>    mem, a ; <b>mov</b>    a, 0x38 ; <b>comp</b>   a, mem ; // C flag is set as 1 </pre> <hr style="border-top: 1px dashed black;"/>
<i>comp</i> M, a	<p>Compare ACC with the content of memory</p> <p>Example: <b><i>comp MEM, a;</i></b></p> <p>Result: Flag will be changed by regarding as ( MEM - a )</p> <p>Affected flags: 『Y』 Z 『Y』 C 『Y』 AC 『Y』 OV</p>

### 7.5. Bit Operation Instructions

<i>set0</i> IO.n	<p>Set bit n of IO port to low</p> <p>Example: <i>set0</i> pa.5 ;</p> <p>Result: set bit 5 of port A to low</p> <p>Affected flags: 『N』 Z 『N』 C 『N』 AC 『N』 OV</p>
<i>set1</i> IO.n	<p>Set bit n of IO port to high</p> <p>Example: <i>set1</i> pb.5 ;</p> <p>Result: set bit 5 of port B to high</p> <p>Affected flags: 『N』 Z 『N』 C 『N』 AC 『N』 OV</p>
<i>swapc</i> IO.n	<p>Swap the nth bit of IO port with carry bit</p> <p>Example: <i>swapc</i> IO.0;</p> <p>Result: <math>C \leftarrow IO.0, IO.0 \leftarrow C</math></p> <p>When IO.0 is a port to output pin, carry C will be sent to IO.0;</p> <p>When IO.0 is a port from input pin, IO.0 will be sent to carry C;</p> <p>Affected flags: 『N』 Z 『Y』 C 『N』 AC 『N』 OV</p> <p>Application Example1 (serial output) :</p> <p>-----</p> <pre> ... set1   pac.0 ;      // set PA.0 as output ... set0   flag.1 ;    // C=0 swapc  pa.0 ;      // move C to PA.0 (bit operation), PA.0=0 set1   flag.1 ;    // C=1 swapc  pa.0 ;      // move C to PA.0 (bit operation), PA.0=1 ... </pre> <p>-----</p> <p>Application Example2 (serial input) :</p> <p>-----</p> <pre> ... set0   pac.0 ;      // set PA.0 as input ... swapc  pa.0 ;      // read PA.0 to C (bit operation) src    a ;          // shift C to bit 7 of ACC swapc  pa.0 ;      // read PA.0 to C (bit operation) src    a ;          // shift new C to bit 7, old C ... </pre> <p>-----</p>
<i>set0</i> M.n	<p>Set bit n of memory to low</p> <p>Example: <i>set0</i> MEM.5 ;</p> <p>Result: set bit 5 of MEM to low</p> <p>Affected flags: 『N』 Z 『N』 C 『N』 AC 『N』 OV</p>
<i>set1</i> M.n	<p>Set bit n of memory to high</p> <p>Example: <i>set1</i> MEM.5 ;</p> <p>Result: set bit 5 of MEM to high</p> <p>Affected flags: 『N』 Z 『N』 C 『N』 AC 『N』 OV</p>

### 7.6. Conditional Operation Instructions

<i>ceqsn a, l</i>	<p>Compare ACC with immediate data and skip next instruction if both are equal. Flag will be changed like as (<math>a \leftarrow a - l</math>) Example: <i>ceqsn a, 0x55</i> ;           <i>inc MEM</i> ;           <i>goto error</i> ; Result: If <math>a=0x55</math>, then “goto error”; otherwise, “inc MEM”. Affected flags: 『Y』 Z 『Y』 C 『Y』 AC 『Y』 OV</p>
<i>ceqsn a, M</i>	<p>Compare ACC with memory and skip next instruction if both are equal. Flag will be changed like as (<math>a \leftarrow a - M</math>) Example: <i>ceqsn a, MEM</i> ; Result: If <math>a=MEM</math>, skip next instruction Affected flags: 『Y』 Z 『Y』 C 『Y』 AC 『Y』 OV</p>
<i>cneqsn a, M</i>	<p>Compare ACC with memory and skip next instruction if both are not equal. Flag will be changed like as (<math>a \leftarrow a - M</math>) Example: <i>cneqsn a, MEM</i> ; Result: If <math>a \neq MEM</math>, skip next instruction Affected flags: 『Y』 Z 『Y』 C 『Y』 AC 『Y』 OV</p>
<i>cneqsn a, l</i>	<p>Compare ACC with immediate data and skip next instruction if both are no equal. Flag will be changed like as (<math>a \leftarrow a - l</math>) Example: <i>cneqsn a, 0x55</i> ;           <i>inc MEM</i> ;           <i>goto error</i> ; Result: If <math>a \neq 0x55</math>, then “goto error”; Otherwise, “inc MEM”. Affected flags: 『Y』 Z 『Y』 C 『Y』 AC 『Y』 OV</p>
<i>t0sn IO.n</i>	<p>Check IO bit and skip next instruction if it's low Example: <i>t0sn pa.5</i> ; Result: If bit 5 of port A is low, skip next instruction Affected flags: 『N』 Z 『N』 C 『N』 AC 『N』 OV</p>
<i>t1sn IO.n</i>	<p>Check IO bit and skip next instruction if it's high Example: <i>t1sn pa.5</i> ; Result: If bit 5 of port A is high, skip next instruction Affected flags: 『N』 Z 『N』 C 『N』 AC 『N』 OV</p>
<i>t0sn M.n</i>	<p>Check memory bit and skip next instruction if it's low Example: <i>t0sn MEM.5</i> ; Result: If bit 5 of MEM is low, then skip next instruction Affected flags: 『N』 Z 『N』 C 『N』 AC 『N』 OV</p>
<i>t1sn M.n</i>	<p>Check memory bit and skip next instruction if it's high EX: <i>t1sn MEM.5</i> ; Result: If bit 5 of MEM is high, then skip next instruction Affected flags: 『N』 Z 『N』 C 『N』 AC 『N』 OV</p>
<i>izsn a</i>	<p>Increment ACC and skip next instruction if ACC is zero Example: <i>izsn a</i> ; Result: <math>a \leftarrow a + 1</math>, skip next instruction if <math>a = 0</math> Affected flags: 『Y』 Z 『Y』 C 『Y』 AC 『Y』 OV</p>

<i>dzn a</i>	Decrement ACC and skip next instruction if ACC is zero Example: <i>dzn a</i> ; Result: $A \leftarrow A - 1$ , skip next instruction if $a = 0$ Affected flags: 『Y』 Z 『Y』 C 『Y』 AC 『Y』 OV
<i>izn M</i>	Increment memory and skip next instruction if memory is zero Example: <i>izn MEM</i> ; Result: $MEM \leftarrow MEM + 1$ , skip next instruction if $MEM = 0$ Affected flags: 『Y』 Z 『Y』 C 『Y』 AC 『Y』 OV
<i>dzn M</i>	Decrement memory and skip next instruction if memory is zero Example: <i>dzn MEM</i> ; Result: $MEM \leftarrow MEM - 1$ , skip next instruction if $MEM = 0$ Affected flags: 『Y』 Z 『Y』 C 『Y』 AC 『Y』 OV

### 7.7. System control Instructions

<i>call label</i>	Function call, address can be full range address space Example: <i>call function1</i> ; Result: $[sp] \leftarrow pc + 1$ $pc \leftarrow function1$ $sp \leftarrow sp + 2$ Affected flags: 『N』 Z 『N』 C 『N』 AC 『N』 OV
<i>goto label</i>	Go to specific address which can be full range address space Example: <i>goto error</i> ; Result: Go to error and execute program. Affected flags: 『N』 Z 『N』 C 『N』 AC 『N』 OV
<i>ret I</i>	Place immediate data to ACC, then return Example: <i>ret 0x55</i> ; Result: $A \leftarrow 55h$ <i>ret</i> ; Affected flags: 『N』 Z 『N』 C 『N』 AC 『N』 OV
<i>ret</i>	Return to program which had function call Example: <i>ret</i> ; Result: $sp \leftarrow sp - 2$ $pc \leftarrow [sp]$ Affected flags: 『N』 Z 『N』 C 『N』 AC 『N』 OV
<i>reti</i>	Return to program that is interrupt service routine. After this command is executed, global interrupt is enabled automatically. Example: <i>reti</i> ; Affected flags: 『N』 Z 『N』 C 『N』 AC 『N』 OV
<i>nop</i>	No operation Example: <i>nop</i> ; Result: nothing changed Affected flags: 『N』 Z 『N』 C 『N』 AC 『N』 OV



<i>pcadd a</i>	<p>Next program counter is current program counter plus ACC.          Example: <i>pcadd a</i>;          Result: <math>pc \leftarrow pc + a</math>          Affected flags: 『N』 Z 『N』 C 『N』 AC 『N』 OV          Application Example:</p> <hr style="border-top: 1px dashed black;"/> <pre> ... mov    a, 0x02 ; pcadd  a ;           // PC &lt;- PC+2 goto   err1 ; goto   correct ;    // jump here goto   err2 ; goto   err3 ;  ... correct:           // jump here ... </pre> <hr style="border-top: 1px dashed black;"/>
<i>engint</i>	<p>Enable global interrupt enable          Example: <i>engint</i>;          Result: Interrupt request can be sent to FPP0          Affected flags: 『N』 Z 『N』 C 『N』 AC 『N』 OV</p>
<i>disgint</i>	<p>Disable global interrupt enable          Example: <i>disgint</i>;          Result: Interrupt request is blocked from CPU          Affected flags: 『N』 Z 『N』 C 『N』 AC 『N』 OV</p>
<i>stopsys</i>	<p>System halt.          Example: <i>stopsys</i>;          Result: Stop the system clocks and halt the system          Affected flags: 『N』 Z 『N』 C 『N』 AC 『N』 OV</p>
<i>stopexe</i>	<p>CPU halt. The oscillator module is still active to output clock, however, system clock is disabled to save power.          Example: <i>stopexe</i>;          Result: Stop the system clocks and keep oscillator modules active.          Affected flags: 『N』 Z 『N』 C 『N』 AC 『N』 OV</p>
<i>reset</i>	<p>Reset the whole chip, its operation will be same as hardware reset.          Example: <i>reset</i>;          Result: Reset the whole chip.          Affected flags: 『N』 Z 『N』 C 『N』 AC 『N』 OV</p>
<i>wdreset</i>	<p>Reset Watchdog timer.          Example: <i>wdreset</i>;          Result: Reset Watchdog timer.          Affected flags: 『N』 Z 『N』 C 『N』 AC 『N』 OV</p>

### 7.8. Summary of Instructions Execution Cycle

2T	<i>goto, call, idxm</i>
1T/2T	<i>ceqsn, t0sn, t1sn, dzsn, izsn</i>
1T	Others

### 7.9. Summary of affected flags by Instructions

Instruction	Z	C	AC	OV	Instruction	Z	C	AC	OV	Instruction	Z	C	AC	OV
<i>mov a, l</i>	-	-	-	-	<i>mov M, a</i>	-	-	-	-	<i>mov a, M</i>	Y	-	-	-
<i>mov a, IO</i>	Y	-	-	-	<i>mov IO, a</i>	-	-	-	-	<i>ldt16 word</i>	-	-	-	-
<i>stt16 word</i>	-	-	-	-	<i>idxm a, index</i>	-	-	-	-	<i>idxm index, a</i>	-	-	-	-
<i>xch M</i>	-	-	-	-	<i>pushaf</i>	-	-	-	-	<i>popaf</i>	Y	Y	Y	Y
<i>add a, l</i>	Y	Y	Y	Y	<i>add a, M</i>	Y	Y	Y	Y	<i>add M, a</i>	Y	Y	Y	Y
<i>addc a, M</i>	Y	Y	Y	Y	<i>addc M, a</i>	Y	Y	Y	Y	<i>addc a</i>	Y	Y	Y	Y
<i>addc M</i>	Y	Y	Y	Y	<i>sub a, l</i>	Y	Y	Y	Y	<i>sub a, M</i>	Y	Y	Y	Y
<i>sub M, a</i>	Y	Y	Y	Y	<i>subc a, M</i>	Y	Y	Y	Y	<i>subc M, a</i>	Y	Y	Y	Y
<i>subc a</i>	Y	Y	Y	Y	<i>subc M</i>	Y	Y	Y	Y	<i>inc M</i>	Y	Y	Y	Y
<i>dec M</i>	Y	Y	Y	Y	<i>clear M</i>	-	-	-	-	<i>sr a</i>	-	Y	-	-
<i>src a</i>	-	Y	-	-	<i>sr M</i>	-	Y	-	-	<i>src M</i>	-	Y	-	-
<i>sl a</i>	-	Y	-	-	<i>slc a</i>	-	Y	-	-	<i>sl M</i>	-	Y	-	-
<i>slc M</i>	-	Y	-	-	<i>swap a</i>	-	-	-	-	<i>and a, l</i>	Y	-	-	-
<i>and a, M</i>	Y	-	-	-	<i>and M, a</i>	Y	-	-	-	<i>or a, l</i>	Y	-	-	-
<i>or a, M</i>	Y	-	-	-	<i>or M, a</i>	Y	-	-	-	<i>xor a, l</i>	Y	-	-	-
<i>xor IO, a</i>	-	-	-	-	<i>xor a, M</i>	Y	-	-	-	<i>xor M, a</i>	Y	-	-	-
<i>not a</i>	Y	-	-	-	<i>not M</i>	Y	-	-	-	<i>neg a</i>	Y	-	-	-
<i>neg M</i>	Y	-	-	-	<i>set0 IO.n</i>	-	-	-	-	<i>set1 IO.n</i>	-	-	-	-
<i>set0 M.n</i>	-	-	-	-	<i>set1 M.n</i>	-	-	-	-	<i>ceqsn a, l</i>	Y	Y	Y	Y
<i>ceqsn a, M</i>	Y	Y	Y	Y	<i>t0sn IO.n</i>	-	-	-	-	<i>t1sn IO.n</i>	-	-	-	-
<i>t0sn M.n</i>	-	-	-	-	<i>t1sn M.n</i>	-	-	-	-	<i>izsn a</i>	Y	Y	Y	Y
<i>dzsn a</i>	Y	Y	Y	Y	<i>izsn M</i>	Y	Y	Y	Y	<i>dzsn M</i>	Y	Y	Y	Y
<i>call label</i>	-	-	-	-	<i>goto label</i>	-	-	-	-	<i>ret l</i>	-	-	-	-
<i>ret</i>	-	-	-	-	<i>reti</i>	-	-	-	-	<i>nop</i>	-	-	-	-
<i>pcadd a</i>	-	-	-	-	<i>engint</i>	-	-	-	-	<i>disgint</i>	-	-	-	-
<i>stopsys</i>	-	-	-	-	<i>stopexe</i>	-	-	-	-	<i>reset</i>	-	-	-	-
<i>wdreset</i>	-	-	-	-	<i>nadd M, a</i>	Y	Y	Y	Y	<i>cneqsn a, l</i>	Y	Y	Y	Y
<i>cneqsn a, M</i>	Y	Y	Y	Y	<i>comp a, M</i>	Y	Y	Y	Y	<i>nadd a, M</i>	Y	Y	Y	Y
<i>comp M, a</i>	Y	Y	Y	Y	<i>swapc IO.n</i>	-	Y	-	-					

### 8. Code Options

Option	Selection	Description
Security	Enable	Security Enable
	Disable	Security Disable
LVR	4.0V	Select LVR = 4.0V
	3.5V	Select LVR = 3.5V
	3.0V	Select LVR = 3.0V
	2.75V	Select LVR = 2.75V
	2.5V	Select LVR = 2.5V
	2.2V	Select LVR = 2.2V
	2.0V	Select LVR = 2.0V
	1.8V	Select LVR = 1.8V
Boot-up_Time	Slow	Please refer to $t_{WUP}$ and $t_{SBP}$ in Section 4.1
	Fast	Please refer to $t_{WUP}$ and $t_{SBP}$ in Section 4.1
Interrupt Src0	PA.0	INTEN/INTRQ.Bit0 is from PA.0
	PB.5	INTEN/INTRQ.Bit0 is from PB.5
Interrupt Src1	PB.0	INTEN/INTRQ.Bit1 is from PB.0
	PA.4	INTEN/INTRQ.Bit1 is from PA.4
GPC_PWM	Disable	Comparator does not control all PWM outputs
	Enable	Comparator controls all PWM outputs (ICE does NOT Support.)
PWM_Source	16MHZ	When Pwmgclk.0= 1, PWMG clock source = IHRC = 16MHZ
	32MHZ	When Pwmgclk.0= 1, PWMG clock source = IHRC*2 = 32MHZ (ICE does NOT Support.)
TM2_Source	16MHZ	When tm2c[7:4]= 0010, TM2 clock source = IHRC = 16MHZ
	32MHZ	When tm2c[7:4]= 0010, TM2 clock source = IHRC*2 = 32MHZ (ICE does NOT Support.)
TM2_Bit	6 Bit	When tm2s.7=1, TM2 PWM resolution is 6 Bit
	7 Bit	When tm2s.7=1, TM2 PWM resolution is 7 Bit (ICE does NOT Support.)
Comparator_Edge	All_Edge	The comparator will trigger an interrupt on the rising edge or falling edge
	Rising_Edge	The comparator will trigger an interrupt on the rising edge
	Falling_Edge	The comparator will trigger an interrupt on the falling edge

## 9. Special Notes

This chapter is to remind user who use PMS152 series IC in order to avoid frequent errors upon operation.

### 9.1. Warning

User must read all application notes of the IC by detail before using it. Please download the related application notes from the following link:

<http://www.padauk.com.tw/technical-application.php>

### 9.2. Using IC

#### 9.2.1. IO pin usage and setting

- (1) IO pin is set to be digital input
  - ◆ When IO is set as digital input, the level of  $V_{ih}$  and  $V_{il}$  would changes with the voltage and temperature. Please follow the minimum value of  $V_{ih}$  and the maximum value of  $V_{il}$ .
  - ◆ The value of internal pull high resistor would also changes with the voltage, temperature and pin voltage. It is not the fixed value.
- (2) IO pin as digital input and enable wakeup function
  - ◆ Configure IO pin as input
  - ◆ Set corresponding bit to “1” in PXDIER
  - ◆ For those IO pins of PA that are not used, PADIER[1:2] should be set low in order to prevent them from leakage.
- (3) PA5 is set to be output pin
  - ◆ PA5 can be set to be Open-Drain output pin only, output high requires adding pull-up resistor.
- (4) PA5 is set to be PRSTB input pin
  - ◆ Configure PA5 as input
  - ◆ Set CLKMD.0=1 to enable PA5 as PRSTB input pin
- (5) PA5 is set to be input pin and to connect with a push button or a switch by a long wire
  - ◆ Needs to put a  $>33\Omega$  resistor in between PA5 and the long wire
  - ◆ Avoid using PA5 as input in such application.
- (6) PA7 and PA6 as external crystal oscillator
  - ◆ Configure PA7 and PA6 as input
  - ◆ Disable PA7 and PA6 internal pull-up resistor
  - ◆ Configure PADIER register to set PA6 and PA7 as analog input
  - ◆ EOSCR register bit [6:5] selects corresponding crystal oscillator frequency :
    - ◇ 01 : for lower frequency, ex : 32KHz (**reserved**)
    - ◇ 10 : for middle frequency, ex : 455KHz, 1MHz
    - ◇ 11 : for higher frequency, ex : 4MHz
  - ◆ Program EOSCR.7 =1 to enable crystal oscillator
  - ◆ Ensure EOSC working well before switching from IHRC or ILRC to EOSC.

### 9.2.2. Interrupt

(1) When using the interrupt function, the procedure should be:

Step1: Set INTEN register, enable the interrupt control bit

Step2: Clear INTRQ register

Step3: In the main program, using ENGINT to enable CPU interrupt function

Step4: Wait for interrupt. When interrupt occurs, enter to Interrupt Service Routine

Step5: After the Interrupt Service Routine being executed, return to the main program

\*Use DISGINT in the main program to disable all interrupts

\*When interrupt service routine starts, use PUSHAF instruction to save ALU and FLAG register.

POPAF instruction is to restore ALU and FLAG register before RETI as below:

```
void Interrupt (void) // Once the interrupt occurs, jump to interrupt service routine
{
    // enter DISGINT status automatically, no more interrupt is
    // accepted
    PUSHAF;
    ...
    POPAF;
} // RETI will be added automatically. After RETI being executed, ENGINT status
// will be restored
```

(2) INTEN and INTRQ have no initial values. Please set required value before enabling interrupt function.

### 9.2.3. System clock switching

System clock can be switched by CLKMD register. Please notice that, NEVER switch the system clock and turn off the original clock source at the same time. For example: When switching from clock A to clock B, please switch to clock B first; and after that turn off the clock A oscillator through CLKMD.

◆ Example : Switch system clock from ILRC to IHRC/2

```
CLKMD = 0x36; // switch to IHRC, ILRC can not be disabled here
```

```
CLKMD.2 = 0; // ILRC can be disabled at this time
```

◆ **ERROR:** Switch ILRC to IHRC and turn off ILRC simultaneously

```
CLKMD = 0x50; // MCU will hang
```

### 9.2.4. Watchdog

Watchdog will be inactive once ILRC is disabled.

### 9.2.5. TIMER time out

When select T16M counter BIT8 as 1 to generate interrupt, the first interrupt will occur when the counter reaches to 0x100 (BIT8 from 0 to 1) and the second interrupt will occur when the counter reaches 0x300 (BIT8 from 0 to 1). Therefore, selecting BIT8 as 1 to generate interrupt means that the interrupt occurs every 512 counts. Please notice that if T16M counter is restarted, the next interrupt will occur once Bit8 turns from 0 to 1.

### 9.2.6. IHRC

- (1) The IHRC frequency calibration is performed when IC is programmed by the writer.
- (2) Because the characteristic of the Epoxy Molding Compound (EMC) would some degrees affects the IHRC frequency (either for package or COB), if the calibration is done before molding process, the actual IHRC frequency after molding may be deviated or becomes out of spec. Normally , the frequency is getting slower a bit.
- (3) It usually happens in COB package or Quick Turnover Programming (QTP). And PADAUK would not take any responsibility for this situation.
- (4) Users can make some compensatory adjustments according to their own experiences. For example, users can set IHRC frequency to be 0.5% ~ 1% higher and aim to get better re-targeting after molding.

### 9.2.7. LVR

User can set **MISC.2** as “1” to disable LVR. However,  $V_{DD}$  must be kept as exceeding the lowest working voltage of chip; Otherwise IC may work abnormally.

### 9.2.8. Instructions

- (1) PMS152 supports 86 instructions.
- (2) The instruction execution cycle of PMS152 is shown as below:

Instruction	Condition	CPU
goto, call, pcadd, ret, reti		2T
ceqsn, cneqsn, t0sn, t1sn, dzsn, izsn	Condition is fulfilled	2T
	Condition is not fulfilled	1T
idxm		2T
Others		1T

### 9.2.9. BIT definition

Bit access of RAM is only available for address from 0x00 to 0x3F.

### 9.2.10. Programming Writing

Put the jumper over the CN39 (P201CS/CD16A) location. Put the PMS152-S14 to move down one space over it. Put the PMS152-M10 to move down three spaces over it. Put the PMS152-S08 to move down four spaces over it.

### 9.3. Using ICE

PDK5S-I-S01/2 supports PMS152 1-FPPA MCU emulation work, the following items should be noted when using PDK5S-I-S01 to emulate PMS152:

- PDK5S-I-S01/2 doesn't support the function of the set of 11-bit SuLED hardware PWM generators.
- PDK5S-I-S01/2 doesn't support the instruction NADD/COMP of PMS152.
- PDK5S-I-S01/2 doesn't support SYSCLK=ILRC/16 of PMS152.
- PDK5S-I-S01/2 doesn't support the function *Tm2.gpcrs* of PMS152.
- The PA3 output function will be affected when GPCS selects output to PA0 output.
- Fast Wakeup time is different from PDK5S-I-S01/2: 128 SysClk, PMS152: 45 ILRC.
- Watch dog time out period is different from PDK5S-I-S01/2:

WDT period	PDK5S-I-S01/2	PMS152
misc[1:0]=00	2048 * T <sub>ILRC</sub>	8192 * T <sub>ILRC</sub>
misc[1:0]=01	4096 * T <sub>ILRC</sub>	16384 * T <sub>ILRC</sub>
misc[1:0]=10	16384 * T <sub>ILRC</sub>	65536 * T <sub>ILRC</sub>
misc[1:0]=11	256 * T <sub>ILRC</sub>	262144 * T <sub>ILRC</sub>