

CIRCUIT DIAGRAM

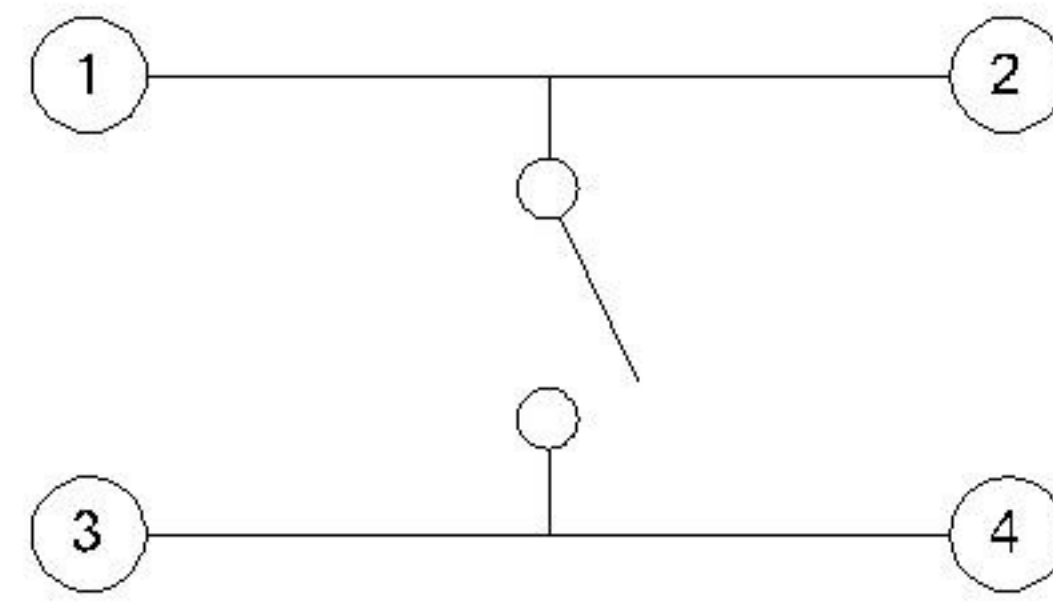

SMD REFLOW PATTERN (N/S : ±0.1)

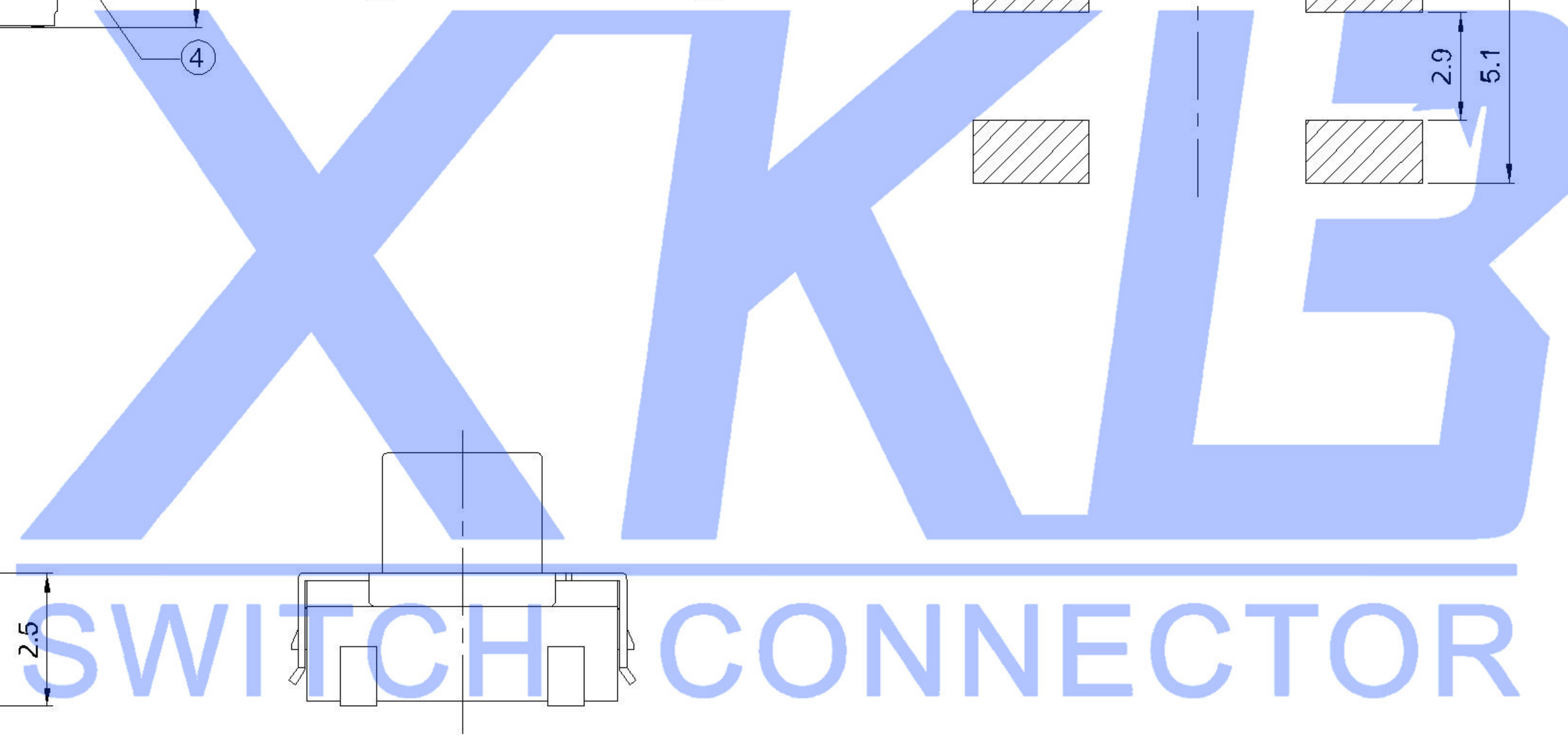
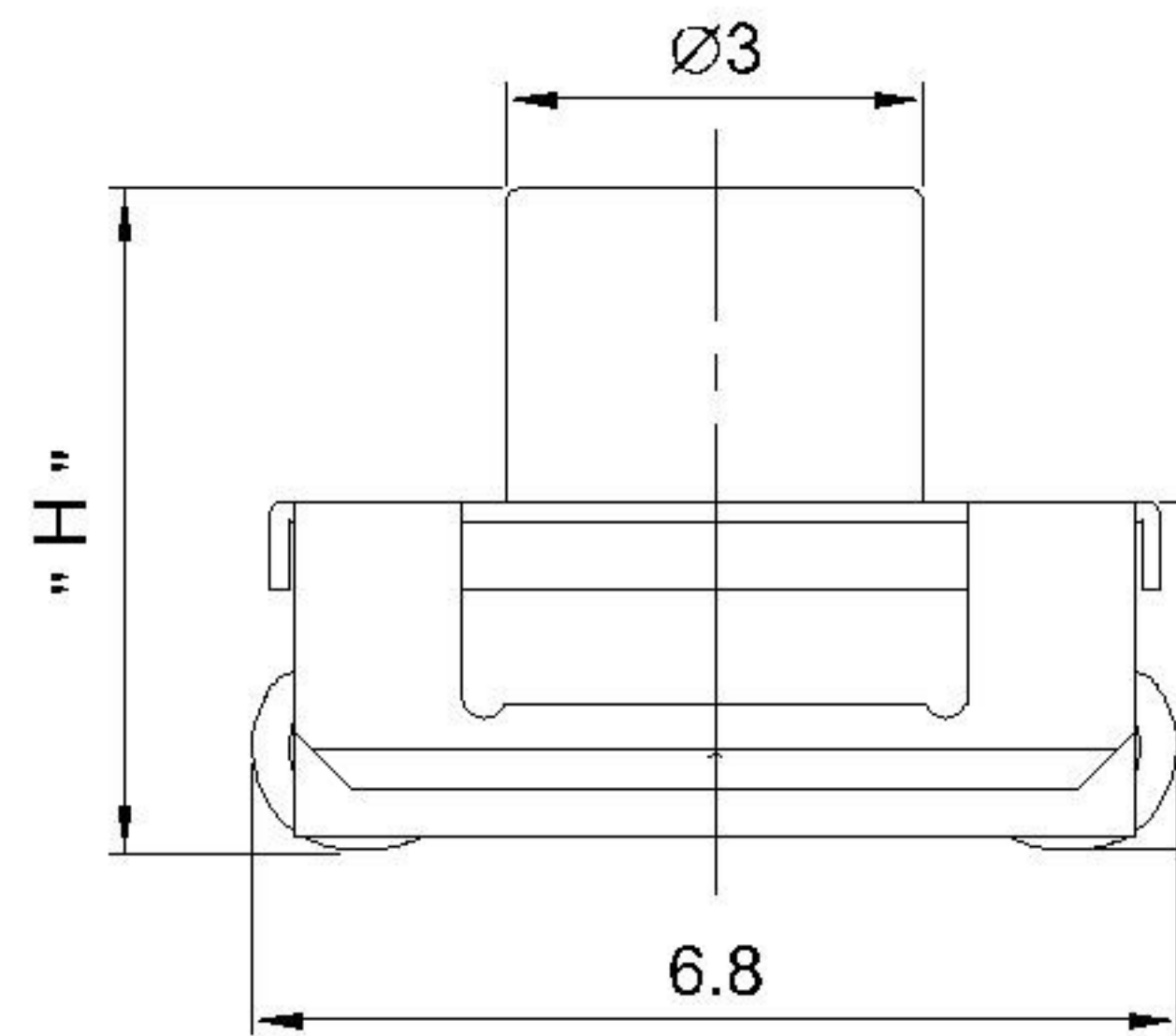
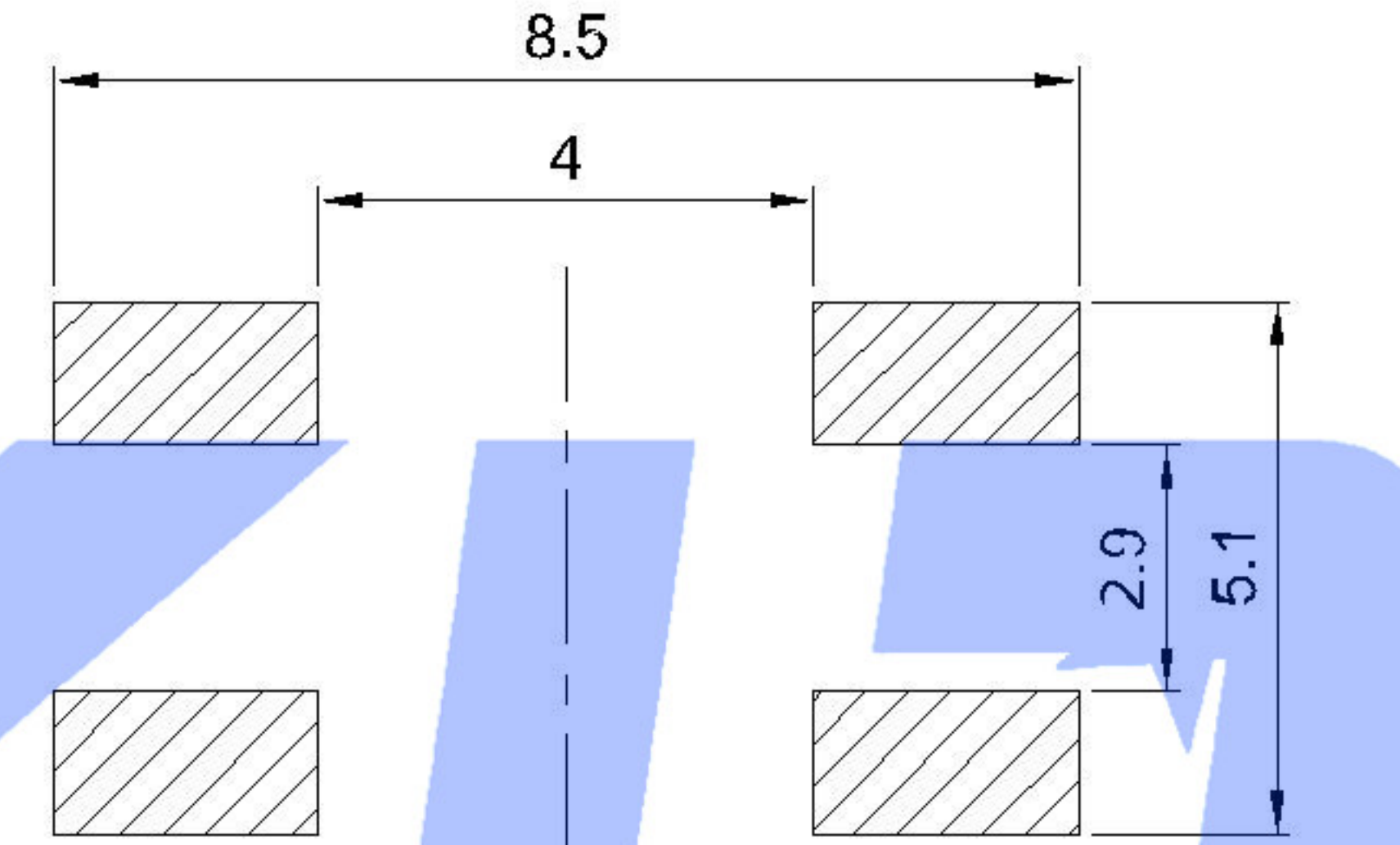

**SPECIFICATION**

Contact Rating 50mA, 12V DC  
 Contact Resistance 100mΩ max.  
 Insulation Resistance 100MΩ min. 500V D  
 Dielectric Strength 250V AC/1 minute  
 Travel 0.25 mm  
 Operating Temp. -25°C +70°C  
 Storage Temp. -30°C +80°C

PAPT NO	TS-1158UB-X-X-X
Operating Force	A:100gf B:160gf C:260gf
Height	H:A:3.1 B:3.5 C:4.3 D:5.0
color	B:blue W:white

⑤	Terminal	—	4	Brass (0.30t)	ag Plated	—
④	Contact	—	1	F.ag/SUS		—
③	Base	—	1	PA46		—
②	Cover	—	1	SPCC	Tin plated	—
①	Keystake	—	1	Silica gel		—
ITEM	PAPT NAMF	TER.NO	QTY	MATERIAL	FINISHING	REMARK

DSND		DATE		SCALE: N/A	MODEL TYPE: <b>TACT SWITCH</b>
DWN		DATE		VIEW:	PART NO.:
CHKD		DATE		UNIT: mm	DWG NO.:
APPD		DATE		SIZE: A4	<b>TS-1158UB-X-X-X</b>
				<b>XKB INDUSTRIAL PRECISION CO.,LIMITED</b>	WEIGHT 1.0g
					SHEET 1/1
					REVISION A0

units: mm  
 tolerance:  
 X.X ±0.2mm  
 X.XX ±0.1mm  
 X.XXX ±0.05mm  
 UNSPECIFIED TOLERANCES

MARK	DESCRIPTION	DATE	REVISED	APPROVED
△X				
△X				
△X				
REVISIONS				
www.xk-dg.cn www.helloxkb.com www.helloxkb.cn				