

SIO VIEW

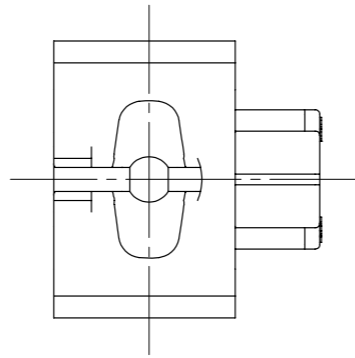

- NOTES -
1. BEFORE USING, CHECK THE HARMFUL CRACK, BURE, ETC.
  2. MARKING & CAV.No. BY AS A GENERAL RULE OF KUM.
  3. APPLICATION PANEL THICKNESS : t = 0.7~1.6mm
  4. COMPLY WITH THE SPECIFIED HOLE OF THE ITEM
  5. PANEL HOLE SIZE

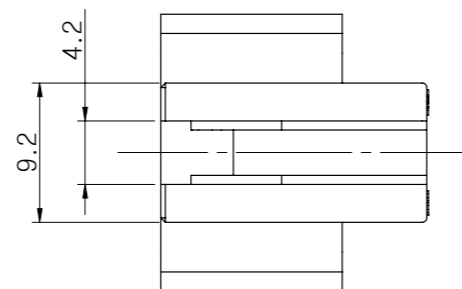
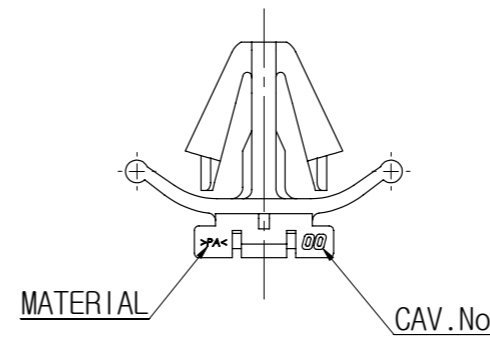
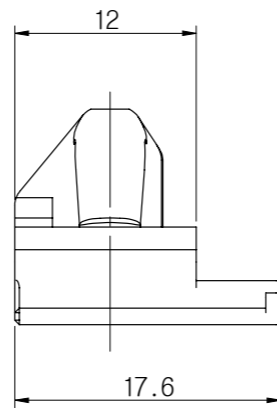
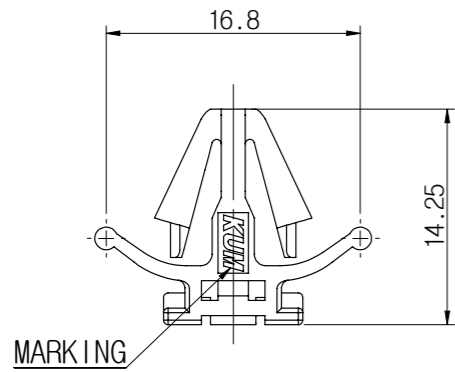
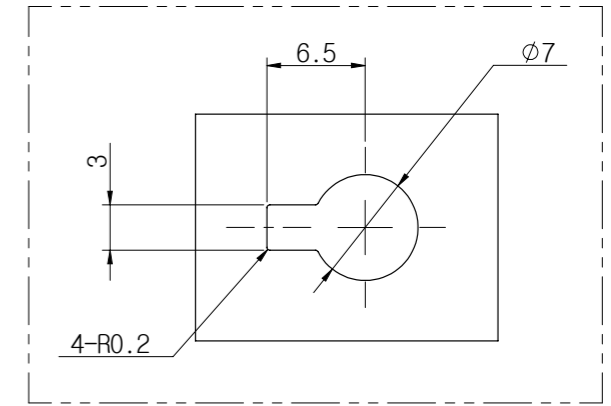

CJW	10.10.20	-	△	RELEASED	JJC
APVD	DATE	NOTE No.	SYM	ALTERATION	DWN

DRAWING NAME			CLIP NIC-A(GY)		
DRAWING No.			GC090-01120-C01		

GENERAL TOLERANCE							
	10MAX	50MAX	100MAX	150MAX	200MAX	200VR	ANGLE
A	±0.2	±0.3	±0.5	±0.8	±1.0	±1.4	±30'

CLIP NIC-A(GY)		GC090-01120		GRAY	PA
PART NAME		PART No.		COLOR	MATERIAL
THIRD ANGLE PROJECTION	A	2/1	LBH	JJC	CJW
	TOLERANCE	SCALE	DESIGN	DRAWN	CHECKED
					APPROVED

**KUM** 케이유엠