

# DATA SHEET

**CURRENT SENSOR - LOW TCR  
AUTOMOTIVE GRADE**

PA1206\_L series

5%, 1%

RoHS compliant & Halogen free



SCOPE

This specification describes PA series current sensor - low TCR with lead-free terminations made by metal substrate.

APPLICATIONS

- Consumer goods
- Computer
- Telecom / Datacom
- Industrial / Power supply
- Alternative Energy
- Car electronics

FEATURES

- AEC-Q200 qualified
- Halogen-free Epoxy
- RoHS compliant
- Reduce environmentally hazardous wastes
- High component and equipment reliability
- Non-forbidden materials used in products/production
- Low resistances applied to current sensing

ORDERING INFORMATION - GLOBAL PART NUMBER

Global part numbers are identified by the series, size, tolerance, packing type, temperature coefficient, taping reel and resistance value.

**GLOBAL PART NUMBER**

**PA    XXXX   X   X   X   XX   XXXX   L**  
(1)    (2) (3) (4)   (5)    (6)    (7)

**(1) SIZE**

1206

**(2) TOLERANCE**

D = ±0.5% (for 5mΩ and up)  
 F = ±1%  
 J = ±5%

**(3) PACKAGING TYPE**

R = Paper taping reel

**(4) TEMPERATURE COEFFICIENT OF RESISTANCE**

F = ± 100ppm/°C  
 M = ± 75ppm/°C  
 E = ± 50ppm/°C

**(5) TAPING REEL**

07 = 7 inch dia. Reel & standard power (1/4W)  
 7W = 7 inch dia. Reel & 2 x standard power (1/2W)  
 47 = 7 inch dia. Reel & 4 x standard power (1W)  
 67 = 7 inch dia. Reel & 6 x standard power (1.5W)

**(6) RESISTANCE VALUE**

1 mΩ to 50 mΩ

**(7) DEFAULT CODE**

Letter L is the system default code for ordering only. (Note)

Resistance code rule	Example
0RXXX	0R001 = 1 mΩ
(1 to 50mΩ)	0R015 = 15 mΩ

**ORDERING EXAMPLE**

The ordering code of a PA1206 1/4W chip resistor, TC100, value 0.003Ω with ±1% tolerance, supplied in 7-inch tape reel is : PA1206FRF070R003L

**NOTE**

1. All our RChip products are RoHS compliant. "LFP" of the internal 2D reel label mentions "Lead-Free Process"

**MARKING**

**PA1206**

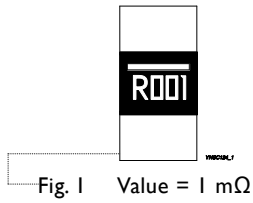

4 digits  
The “R” is used as a decimal point; the other 3 digits are significant  
PA1206: 1mΩ

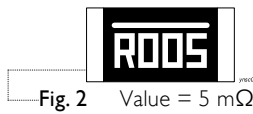

4 digits  
The “R” is used as a decimal point; the other 3 digits are significant  
PA1206: 2mΩ to 50mΩ

**CONSTRUCTION**

The resistors are constructed using outstanding TCR level material, which makes Yageo PA resistors excellent for current sensing application in battery charger circuit & DC-DC converter.

The composition of the resistive material is adjusted to give the approximate required resistance and is covered with a protective coating. Marking is printed on the top side of the resistor.

Finally, the three external terminations (Cu / Ni / matte Tin) are added, as shown in Fig. 3.

**Outlines**

For dimensions, please refer to Table I

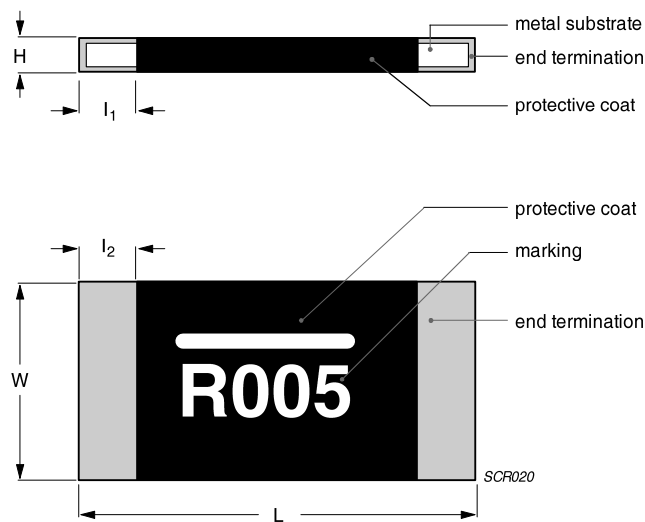

**Fig. 3** Chip resistor outlines

**DIMENSION**

Table 1 For outlines, please refer to Fig. 3

TYPE	RESISTANCE RANGE	POWER RATING	L (mm)	W (mm)	H (mm)	I <sub>1</sub> (mm)	I <sub>2</sub> (mm)
PA1206	1mΩ	1/4W	3.20 ± 0.25	1.60±0.25	0.65±0.25	1.04±0.25	1.04±0.25
	2mΩ ≤ R ≤ 5mΩ	1/2W	3.20 ± 0.25	1.60±0.25	0.65±0.25	0.64±0.25	0.64±0.25
	6mΩ ≤ R ≤ 50mΩ	1W 1.5W (1~5mΩ)	3.20 ± 0.25	1.60±0.25	0.65±0.25	0.51±0.25	0.51±0.25

Note:

1. For relevant physical dimensions, please refer to construction outlines.
2. Please contact with sales offices, distributors and representatives in your region before ordering.

**ELECTRICAL CHARACTERISTICS**

Table 2

SERIES	SIZE	POWER RATING	TOLERANCE	RESISTANCE RANGE	TEMPERATURE COEFFICIENT OF RESISTANCE
PA	1206	1/4W	±1% ±5%	1mΩ ≤ R ≤ 2mΩ	±75ppm/°C, ±100ppm/°C
		1/2W		3mΩ ≤ R ≤ 50mΩ	±50ppm/°C, ±75ppm/°C, ±100ppm/°C
		1W		1mΩ ≤ R ≤ 2mΩ	±75ppm/°C, ±100ppm/°C
		1.5W		3mΩ ≤ R ≤ 5mΩ	±50ppm/°C, ±75ppm/°C, ±100ppm/°C

Note: Please contact with sales offices, distributors and representatives in your region before ordering.

**FUNCTIONAL DESCRIPTION**

**OPERATING TEMPERATURE RANGE**

PA1206 Range: -55°C to +170°C

**POWER RATING**

Standard rated power at 70°C:

For detail power value, please refer to Table 2.

**RATED VOLTAGE**

The DC or AC (rms) continuous working voltage corresponding to the rated power is determined by the following formula:

$$V = \sqrt{P \times R}$$

Where

V = Continuous rated DC or AC (rms) working voltage (V)

P = Rated power (W)

R = Resistance value (Ω)

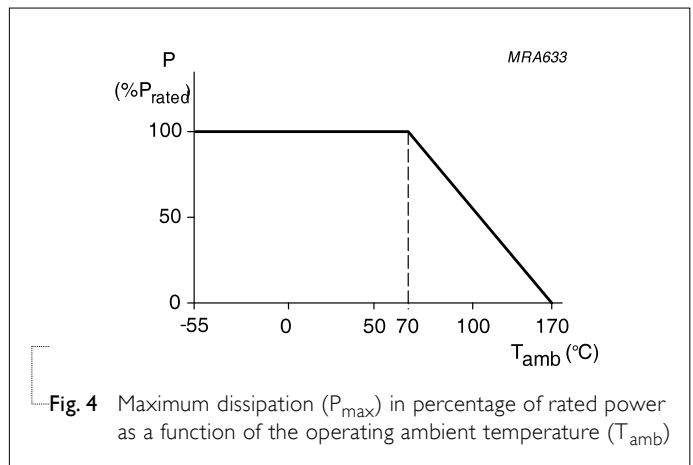

Fig. 4 Maximum dissipation (P<sub>max</sub>) in percentage of rated power as a function of the operating ambient temperature (T<sub>amb</sub>)

**PACKING STYLE AND PACKAGING QUANTITY**

**Table 3** Packing style and packaging quantity

PACKING STYLE	REEL DIMENSION	PA1206
Paper Taping Reel (R)	7" (178 mm)	4,000

**EMBOSSED TAPE**

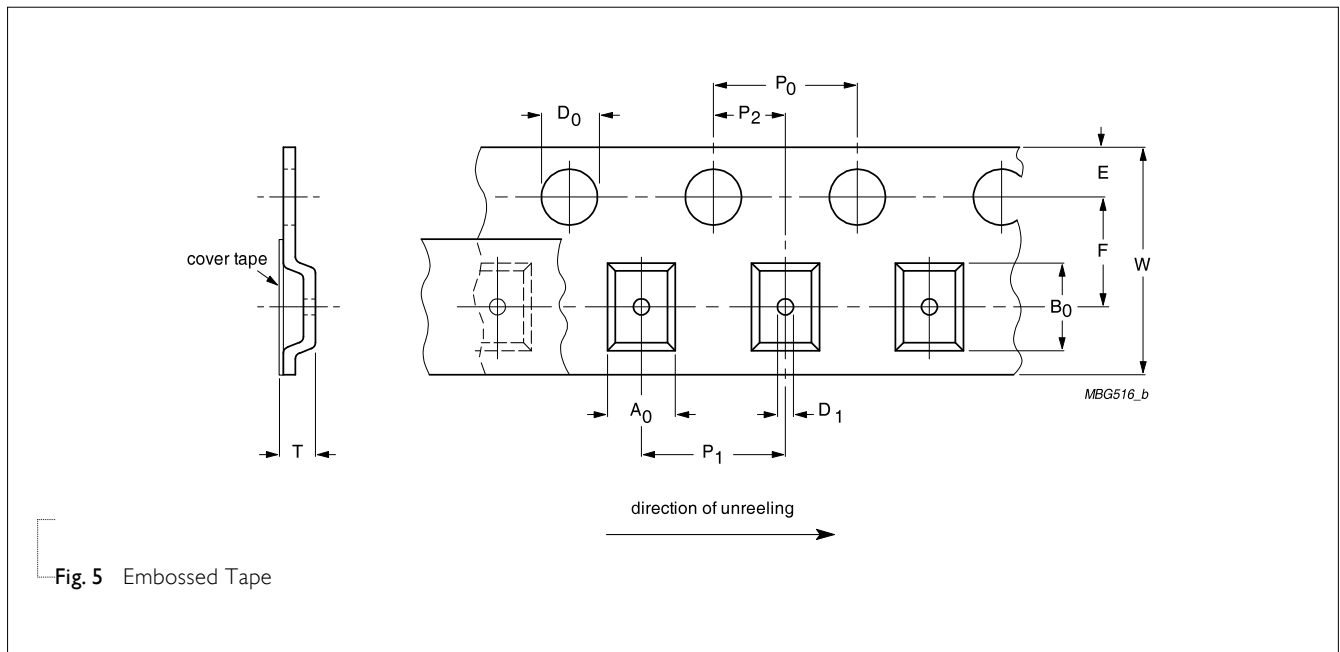

**Fig. 5** Embossed Tape

**Table 4** Dimensions of embossed tape for relevant chip resistors size

SIZE	SYMBOL										Unit: mm
	A <sub>0</sub>	B <sub>0</sub>	W	E	F	P <sub>0</sub>	P <sub>1</sub>	P <sub>2</sub>	ØD <sub>0</sub>	ØD <sub>1</sub>	
<b>PA1206</b>	1.90±0.10	3.50±0.10	8.00±0.30	1.75±0.10	3.50±0.10	4.00±0.10	4.00±0.10	2.00±0.10	1.55±0.05	1.50±0.10	1.50±0.10

**REEL SPECIFICATION**

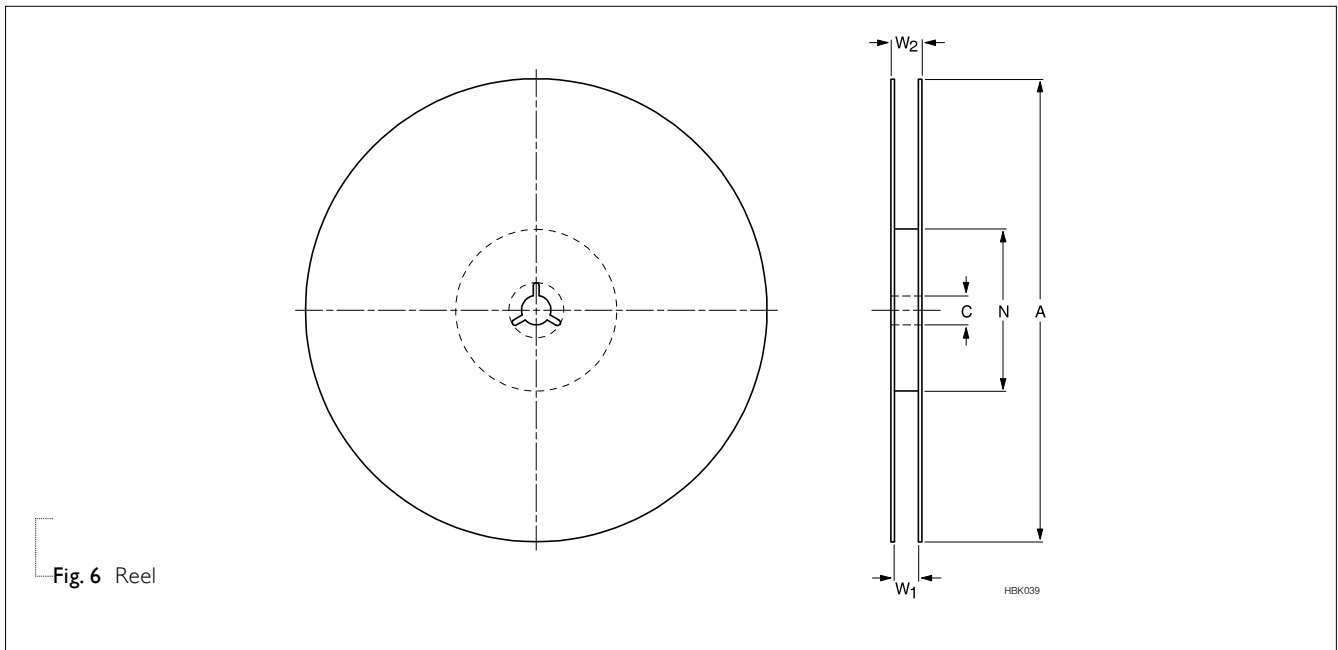
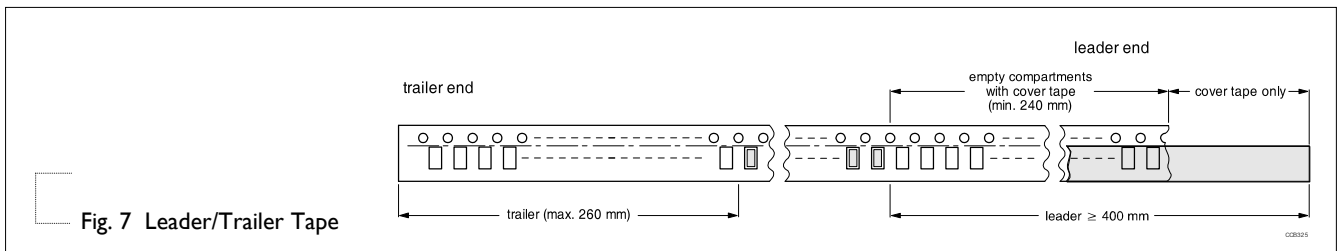

Table 5 Dimensions of reel specification for relevant chip resistors size

SIZE	QUANTITY PER REEL	REEL SIZE		SYMBOL				Unit: mm	
		8 mm TAPE WIDE	12 mm TAPE WIDE	A	N	C	D	W <sub>1</sub>	W <sub>2</sub> MAX.
PA1206	4000	--	7" (Ø178 mm)	180.0+0/-3	60.0+1/-0	13.0± 0.2	21.0±0.8	8.4 +1/-0	12.4

**LEADER/TRAILER TAPE SPECIFICATION**



**FOOTPRINT AND SOLDERING PROFILES**

For recommended soldering profiles, please refer to data sheet “Chip resistors mounting”.

**FOOTPRINT**

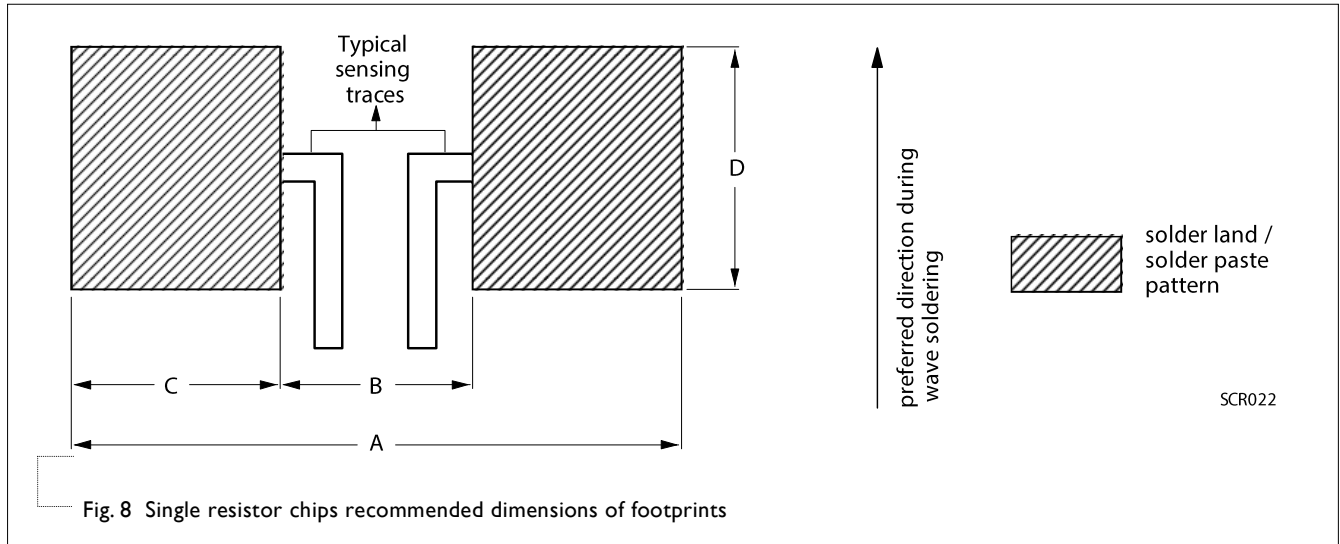

Table 6 Footprint dimensions

SIZE	RESISTANCE RANGE	Unit: mm			
		A	B	C	D
PA1206	$1\text{m}\Omega \leq R \leq 50\text{m}\Omega$	3.90	0.76	1.57	1.78

**TESTS AND REQUIREMENTS**

Table 7 Test condition, procedure and requirements

TEST	TEST METHOD	PROCEDURE	REQUIREMENT
Short time overload	IEC60115-1 4.13	5 times of rated power for 5 seconds at room temperature	$\pm(0.5\%+0.0005\Omega)$ No visible damage
High Temperature Exposure	MIL-STD-202-Method 108	1,000 hours at maximum operating temperature depending on specification, unpowered  No direct impingement of forced air to the parts Tolerances: $170\pm 3^{\circ}\text{C}$	$\pm(1.0\%+0.0005\Omega)$
Temperature Cycling	JESD22-A104C	1,000 cycles, $-55/+125^{\circ}\text{C}$ for 1 cycle per hour	$\pm(0.5\%+0.0005\Omega)$
Moisture Resistance	MIL-STD-202-Method 106	Each temperature / humidity cycle is defined at 8 hours (method 106F), 3 cycles / 24 hours for 10d with $25^{\circ}\text{C}$ / $65^{\circ}\text{C}$ 95% R.H, without steps 7a & 7b, unpowered	$\pm(0.5\%+0.0005\Omega)$
Biased Humidity	MIL-STD-202 Method 103	1,000 hours; $85^{\circ}\text{C}$ / 85% RH  10% of operating power	$\pm(0.5\%+0.0005\Omega)$
Operational Life/ Endurance	MIL-STD-202-Method 108	1,000 hours at $125\pm 3^{\circ}\text{C}$ , de-rated voltage applied for 1.5 hours on, 0.5 hour off, still-air required	$\pm(1.0\%+0.0005\Omega)$
		1,000 hours at $70\pm 2^{\circ}\text{C}$ applied RCWV  1.5 hours on, 0.5 hour off, still air required	$\pm(1.0\%+0.0005\Omega)$
Resistance to Solvents	MIL-STD-202 Method 215	Immerse in isopropyl alcohol for 5 min with ultrasonic at room temperature	No Visible damage
Mechanical Shock	MIL-STD-202 Method 213	Three shocks in each direction shall be applied along the three mutually perpendicular axes of the test specimen.  Peak value: 100 g's  Duration: 6 ms  Velocity change: 12.3 ft/s  Waveform: Half sine	$\pm(0.5\%+0.0005\Omega)$
Vibration	MIL-STD-202 Method 204	5 g's for 20 min., 12 cycles each of 3 orientations  Test from 10-2000 Hz.	$\pm(0.5\%+0.0005\Omega)$
Resistance to Soldering Heat	MIL-STD-202-method 210	Condition B, no pre-heat of samples  Leadfree solder, $260^{\circ}\text{C}$ , 10 seconds immersion time  Procedure 2 for SMD: devices fluxed and cleaned with isopropanol	$\pm(0.5\%+0.0005\Omega)$ No visible damage
Thermal Shock	MIL-STD-202 Method 107	$-55/+125^{\circ}\text{C}$ , Number of cycles is 300.  Devices mounted.  Maximum transfer time is 20 seconds.  Dwell time is 15 minutes. Air -Air	$\pm(0.5\%+0.0005\Omega)$ No visible damage



TEST	TEST METHOD	PROCEDURE	REQUIREMENT
Electrostatic Discharge	AEC-Q200-002	Human Body Model, 1 pos + 1 neg. Discharges 1206=2KV	±(1.0%+0.0005Ω) No visible damage
Solderability - Wetting	J-STD-002B test B	(a) Method B, aging 4 hours at 155°C dry heat, dipping at 235±3°C for 5±0.5 seconds.  (b) Method B, steam aging 8 hours, dipping at 215±3°C for 5±0.5 seconds.  (c) Method D, steam aging 8 hours, dipping at 260±3 °C for 7±0.5 seconds.	Well tinned (>95% covered) No visible damage
Flammability	UL94	Try to inflame a specimen by a needle flame	No ignition of specimen; V-0
Board Flex / Bending	AEC-Q200-005	Chips mounted on a 90mm glass epoxy resin PCB (FR4), Bending for 1206=2 mm Holding time: Min.60 seconds	±(1.0%+0.0005Ω)
Terminal Strength (SMD)	AEC-Q200-006	Applied a 17.7N (1.8Kg) for 60±1 seconds.	±(1.0%+0.0005Ω) No visible damage
Flame Retardance	AEC-Q200-001	Apply voltage from 9V to 32V to increase the surface temp to 350°C	No flame, no explosion
Temperature Coefficient of Resistance (T.C.R.)	MIL-STD-202 Method 304	At +25/+150°C Formula: $T.C.R = \frac{R_2 - R_1}{R_1(t_2 - t_1)} \times 10^6 (\text{ppm}/^\circ\text{C})$ Where t1=+25°C or specified room temperature t2=+150°C test temperature R1=resistance at reference temperature in ohms R2=resistance at test temperature in ohms	Refer to table 2
Flower-of-Sulfur (FOS)	Modified ASTM B809-95	Sulfur 105°C, 750 hours, unpowered.	±(1.0%+0.0005Ω)

REVISION HISTORY

REVISION	DATE	CHANGE NOTIFICATION	DESCRIPTION
Version 2	Jul. 24, 2017	-	- Add part number coding details for the relationship between taping reel and rated power
Version 1	May 05, 2017	-	- Extend resistor value
Version 0	Mar. 31, 2017	-	- New datasheet for automotive grade current sensor –PA1206_L series.

*“Yageo reserves all the rights for revising the content of this datasheet without further notification, as long as the products itself are unchanged. Any product change will be announced by PCN.”*