

東莞市皓宇電子有限公司 DONGGUAN HOOYA ELECTRONICS CO.,LTD.	文件編號	HY-WI-32
	發行日期	2008-07-23
SPECIFICATION 承認書	第 B-2 版	第 1 頁 共 3 頁

SERIES 產品系列	DIN SOCKET DIN 端子	TYPE 產品型號	DIN-318 環保
DRAWN 設計	LI JIAN	APVD 審批	李劍
1 · RATING (額定值): DC50V 1A	CONSTRUCTION DIMENSION 結構尺寸		Apply to the appended drawing. 符合附加圖紙
2 · OPERATING TEMPERATURE RANGE 操作溫度範圍	-20°C~70°C	PRESERVATIVE TEMPERATURE RANGE 儲存溫度範圍	15°C~35°C
ITEM 項目	TEST CONDITIONS 測試條件		SPECIFICATIONS 規格
3 · ELECTRICAL PERFORMANCE (電氣性能規格):			
3A	CONTACT RESISTANCE 接觸電阻	MEASURED BY THE CONTACT RESISTANCE APPARATUS OR mΩ METER AT 0.1A DC5V .THE RESULT IS THE AVERAGE OF5 SUCCESSIVE MEASUREMENTS. 在電壓為 5V，直流電流為 0.1A 時，用接觸電阻測量儀或毫歐表測量。結果取測量 5 次後的平均值。	50mΩ max 50 毫歐以下
3B	INSULATION RESISTANCE 絕緣阻抗	A VOLTAGE OF250V DC SHALL BE APPLIED FOR 1 MIN. AFTER WHICH MEASUREMENT SHALL BE MADE. BETWEEN TERMINALS BETWEEN INDIVIDUAL TERMINALS AND FRAME 輸入 250V DC 電壓 1 分鐘,按以下接觸方法測試 (1) 接觸端子之間 (2) 插座本體與端子之間	100MΩ min 100 兆歐以上.
3C	DIELECTRIC STRENGTH 耐電壓	A VOLTAGE OF750V AC SHALL BE APPLIED FOR 1 MIN. AFTER WHICH MEASUREMENT SHALL BE MADE. 0.5 mA Max voltage 50 hz leakage,BETWEEN TERMINALS , BETWEEN INDIVIDUAL TERMINALS AND FRAME 輸入 750V AC 電壓 1 分鐘,电压50Hz漏电0.5mA max按以下接觸方法測試 (3) 接觸端子之間 (4) 插座本體與端子之間	WITHOUT DAMAGE TO PARTS ARCING OR BREAKDOWN ETC 沒有損傷 變形絕緣破壞等異常.
4.MECHANICAL PERFORMANCE(機械性能規格)			
4A	INSERTION AND WITHDRAW FORCE 插拔力	Being measure at across spring piece and across matching plug for ergometer 用測力計在插頭與彈片之間進行測量。(空插三次後測試)	Insertion and extraction force 5-35N 插拔力 5-35 牛頓
4B	TERMINAL STRENGTH 端子強度	A STATIC LOAD OF 5 N(500gf) SHALL BE APPLIED TO THE TIP OF THE TERMINALS FOR 60 SEC. IN ANY DIRECTION 在任意一個方向的先端上加力度 5N(500gf)60 秒鐘	ELECTRICAL CHARACTERISTICS SHALL BE SATISFIED.WITHOUT DAMAGE OR EXCESSIVE LOOSEN-ESS OF ACTUATOR 在端子中沒有裂開\鬆動等異常滿足於電器性能.
4C	STANDARD ATMOSPHEIC CONDITIONS 使用標準狀態	UNLESS OTHERWISE SPECIFIED. THE STANDRD RANGE OF ATMOSPHERIC CONDITIONS FOR MAKING MEASUREMENTS AND TESTS ARE AS FOLLOWS: AMDIENT TEMPERATURE: 15°C TO 35°C RELATIVE HUMIDITY :25%TO75%RH AIR PRESSURE :80Kpa TO 106Kpa	在沒有指定的情況下測試溫度濕度、氣壓如下： (1) 溫度為 15°C~35°C (2) 濕度為 25%~75%RH (3) 氣壓 80Kpa ~106Kpa

東莞市皓宇電子有限公司 DONGGUAN HOOYA ELECTRONICS CO.,LTD.	文件編號	HY-WI-32
	發行日期	2008-07-23
SPECIFICATION 承認書	第 B-2 版	第 2 頁 共 3 頁

5 · DURABILITY (耐久性)			
5A	SOLDERABILITY TEST 可焊性試驗	<p>THE TOP OF THE TERMINALS SHALL BEDIPPED 2mm IN THE SOLDER BATH OF 230 ± 5 °C FOR 3 ± 0.5 SECONDS. THE PLASTIC BODY IS 1.6mm ABOVE THE TIN LIGUID.</p> <p>端子頂部被浸入焊錫池中 2mm 深，溫度為 230±5℃，時間為 3± 0.5 秒。手工焊接溫度為 350±5℃，時間為 2±0.5 秒。膠身距離錫液 1.6mm。</p> <p>注：本產品只適合用手焊、波峰焊。</p>	<p>(1) SOLDER WETTING TIME SHALL BE 3 SEC OR LESS 焊接時間應少於 3 秒</p> <p>(2) THE AREA OF SOLDERABILITY SHOULD BE OVER 90% 焊接面積要有 90%以上</p>
5B	RESISTANCE TO SOLDERING HEAT TEST 耐焊性試驗	<p>THE TOP OF THE TERMINALS SHALL BEDIPPED 2mm . THE PLASTIC BODY IS 1.6mm ABOVE THE TIN LIGUID.</p> <p>端子頂部被浸入焊錫池中 2mm 深，膠身距離錫液 1.6mm。</p> <p>Wave-soldering is to be performed within 10seconds at 260 +/-5 °C 波峰焊接溫度 260 +/-5℃ 時間 10 秒。</p> <p>Hand weilding to be performed within 3 seconds at 380°C or below. 手工焊接溫度為 380°C 或以內，時間為 3±0.5 秒。</p> <p>注：本產品只適合用手焊、波峰焊。</p>	<p>WITHOUT DEFORMATION OF CASE OREXCESSIVE LOOSENESS OF TERMINALSELECTRICAL CHARACTERISTICS SHALL BE SATISFIED.</p> <p>本體無變形，能滿足於機械、電氣性能。</p>
5C	LIFE TEST. 壽命試驗	<p>WITHOUT LOAD (IT IS TESTED BY MACHINE, ACTING FORCE MUST BE PARALLED TO THE WAY OF PUSHING) :</p> <p>AN ACTUATOR SHALL BE SUBIECT TO 1000 CYCLES AT A SPEED OF 30 CYCLES FOR 1 MIN</p> <p>無負荷（只限於機器測試，作用力平行於插拔方向）： 操作者以每分鐘 30 次的頻率作 1000 回之無負荷測試。</p>	<p>(1) CONTACT RESISTANCE SHALLBE 100mΩ max</p> <p>(2) MECHANICAL AND ELECTRICAL CHARACTERISTICS SHALL BESATISFIED。</p> <p>(1) 接觸電阻不能超於 100mΩ</p> <p>(2) 其他滿足於機械電器性能。</p>
5D	HEAT TEST. 耐熱試驗	<p>85±2°C FOR 48 HOURS AFTER TEST KEEP IN NORMAL CONDITION FOR 30 MINUTES.</p> <p>在 85±2°C 環境中放 48 小時，再放在正常環境中 30 分鐘後進行測試。</p>	<p>THERE SHALL BE NO DAMAGE ON APPEARANCE。</p> <p>MECHANICAL AND ELECTRICAL CHARACTERISTICS SHALL BE SATISFIED</p> <p>外觀無異常，滿足於機械，電器性能。</p>
5E	HUMIDITY TEST. 耐濕試驗	<p>40 ± 2 °C 90-96%RH FOR 48 HOURS, TEST AFTER KEEPING IN NORMAL CONDITION FOR 30 MIN.</p> <p>在 40±2°C 90—96%RH 環境中放 48 小時，再放在正常環境中，30 分鐘後進行測試。</p>	
5F	COLD TEST. 耐冷試驗	<p>At -40±2°C for 48 HRS. AFTER TEST KEEP IN NORMAL CONDITION FOR 30 MIN.</p> <p>在-40±2°C 環境中放 48 小時，再置於正常環境中 30 分鐘後進行測試。</p>	
5G	SALT SPRAY TEST 噴霧試驗	<p>AT 5% NACL LIQUOR FOR 24HOURS, AFTER WASHING, KEEP IN NORMAL CONDITION FOR 30 MIN.</p> <p>5%的 Nacl 溶液中噴霧 24 小時，用水清洗並在室溫下放置 30 分鐘</p>	<p>WITHOUT EXCESSIVE CORROSION OR CRACK IN APPEARANCE</p> <p>表面無明顯腐蝕或鍍層脫落現象</p>

東莞市皓宇電子有限公司 DONGGUAN HOOYA ELECTRONICS CO.,LTD.	文件編號	HY-WI-32
SPECIFICATION 承認書	發行日期	2008-07-23
	第 B-2 版	第 3 頁 共 3 頁

6 · 注意事項 (APPLICATION NOTES:)

1、在耐焊接過程中,不得把松香等絕緣、有腐蝕性物質浸入產品內。

(ROSIN AND OTHER INSULATING AND CAUSTIC MATERIAL CAN NOT BE DIPPED INTO THE ROCKET DURING SOLDERING.)

2、產品焊接後不能用氣槍吹或用溶劑沖洗。

(PRODUCTS CAN NOT BE BLOWN WITH AIR GUN OR CLEANED WITH A SOLVENT AFTER SOLDERING.)

3、產品焊接前各零件不能被溶化。

(ALL PARTS OF THE PRODUCTS CAN NOT BE DISSOLVED BEFORE SOLDERING.)

4、避免儲藏於高溫、潮濕及腐蝕的場所。

(AVOID STORING THE PRODUCTS IN A PLACE AT HIGH TEMPERATURE, HIGH HUMIDITY AND IN CORROSIVE GASES.)

5、貯存期限:自發貨之日起,貯存期不超過 180 天.若超出貯存期限,產生不良品,本公司概不負責。

(SHELF LIFE IS LESS THAN 180 DAYS SINCE THE GOODS WARE SENT OUT FROM OUR FACTORY. OUR COMPANY DOESN'T ACCEPT RESPONSIBILITY FOR REJECTS IF THE SHELF LIFE OF GOODS EXCEEDS 180 DAYS.)

6、本產品如有不良事件,望廠家及時回饋,以便及時記錄、查核、改善、跟蹤。

(PLEASE FEEL FREE TO REPORT TO US IF YOU DISCOVER THE INFERIOR GOODS, SO THAT WE CAN TAKE NOTE, CHECK, TRACK AND IMPROVE THEM. THANKS.)

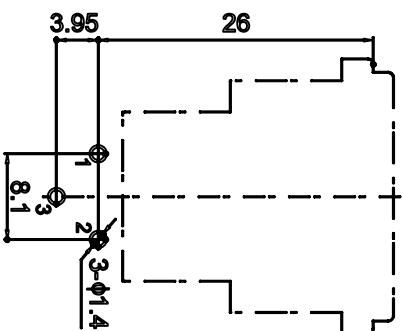
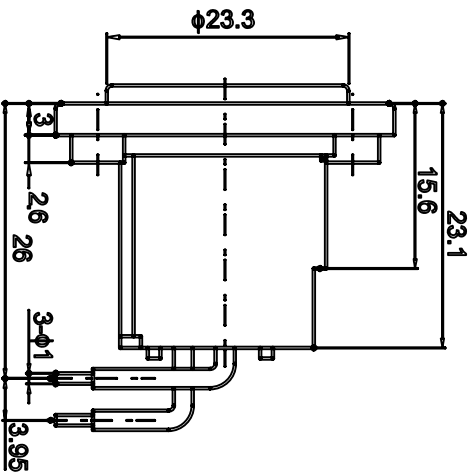
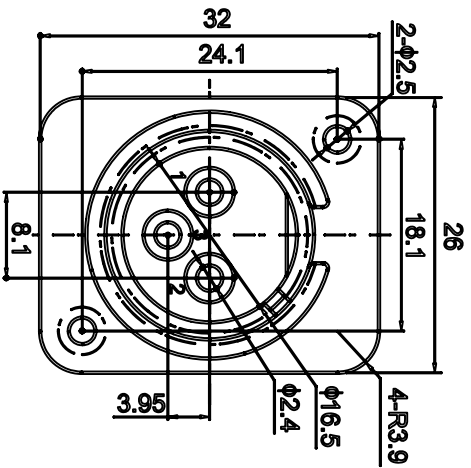

PCB LAYOUT
(VIEWED FROM COPPER SIDE)

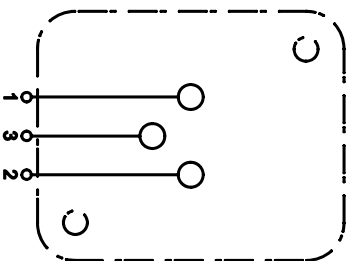

SCHEMATIC LAYOUT

锁紧方式: 无锁扣片 (No Locking Plate)
接地方式: 无接地片 (No Ground Link)

NO.		PART NAME		MATERIAL		QTY		FINISHING	
2		CONTACT FOOT		BRASS		3		Sn-PLATED	
1		HOUSING		PBT		1		BLACK	
<p style="text-align: center;">TOLERANCE UNLESS SPECIFIED</p> <p>UP TO 5mm: ±0.1 ABOVE 5mm: ±0.2</p> <p style="text-align: center;">TITLE: DIN SOCKET</p> <p>MODEL: DIN-319</p>									
NO		DATE		REVISIONS		UNIT : MM		ROHS COMPLIANT	
BY		APPD		DWN		CHK'D		APPD	
PRO.AGI.		APPD		APPD		APPD		APPD	



HOOYA ELECTRONIC CO. LTD
皓宇电子有限公司

