

»Features

- 300 Watts peak pulse power ($t_p = 8/20\mu s$)
- Bidirectional and unidirectional configurations
- Solid-state silicon-avalanche technology
- Low clamping voltage
- Low leakage current
- Low capacitance ($C_j = 60$ pF typ.)
- Protection two data lines
- IEC 61000-4-2 ± 30 kV contact ± 30 kV air
- IEC 61000-4-4 (EFT) 40A(5/50ns)
- IEC 61000-4-5 (Lightning) 12A(8/20 μs)

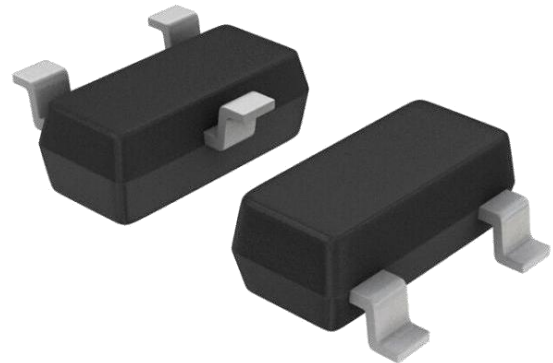

»Applications

- Dataline
- Automatic Teller Machines
- Net works
- Power line

»Mechanical Data

- SOT23-3L package
- Molding compound flammability rating: UL 94V-0
- Packaging: Tape and Reel
- RoHS/WEEE Compliant

»Schematic & PIN Configuration

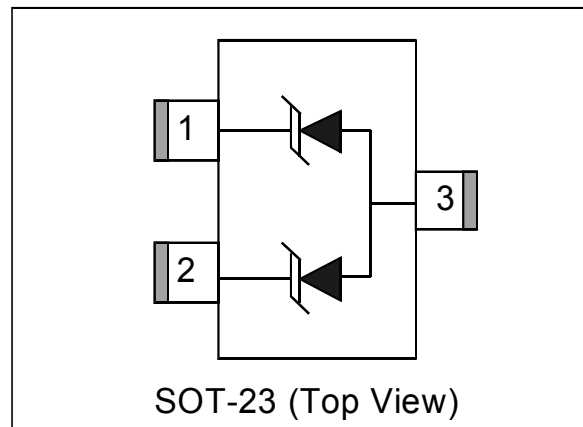
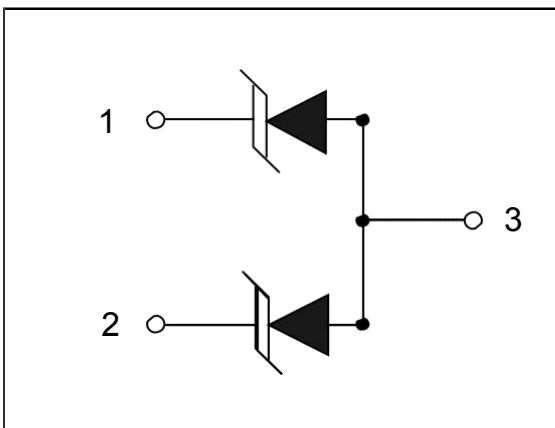

»Absolute Maximum Rating

Rating	Symbol	Value	Units
Peak Pulse Power ($t_p=8/20\mu s$)	P_{PP}	300	Watts
Peak Pulse Current ($t_p=8/20\mu s$)(note1)	I_{pp}	12	A
ESD per IEC 61000-4-2(Air) ESD per IEC 61000-4-2(Contact)	V_{ESD}	30 30	kV
Lead Soldering Temperature	T_L	260(10seconds)	°C
Junction Temperature	T_J	-55 to + 125	°C
Storage Temperature	T_{stg}	-55 to + 125	°C

»Electrical Characteristics

Parameter	Symbol	Conditions	Min	Typical	Max	Units
Reverse Stand-Off Voltage	V_{RWM}				12	V
Reverse Breakdown Voltage	V_{BR}	$I_T=1mA$	13.3	15	17	V
Reverse Leakage Current	I_R	$V_{RWM}=12V, T=25^\circ C$		0.5	1	μA
Peak Pulse Current	I_{pp}	$t_p=8/20\mu s$			10	A
Clamping Voltage	V_C	$I_{pp}=12A, t_p=8/20\mu s$			30	V
Junction Capacitance	C_j	$V_R = 0V, f = 1MHz$ (Pin1 · Pin2 to Pin3)		60	65	pF

»Electrical Parameters (TA = 25°C unless otherwise noted)

Symbol	Parameter
I_{PP}	Maximum Reverse Peak Pulse Current
V_C	Clamping Voltage @ I_{PP}
V_{RWM}	Working Peak Reverse Voltage
I_R	Maximum Reverse Leakage Current @ V_{RWM}
V_{BR}	Breakdown Voltage @ I_T
I_T	Test Current

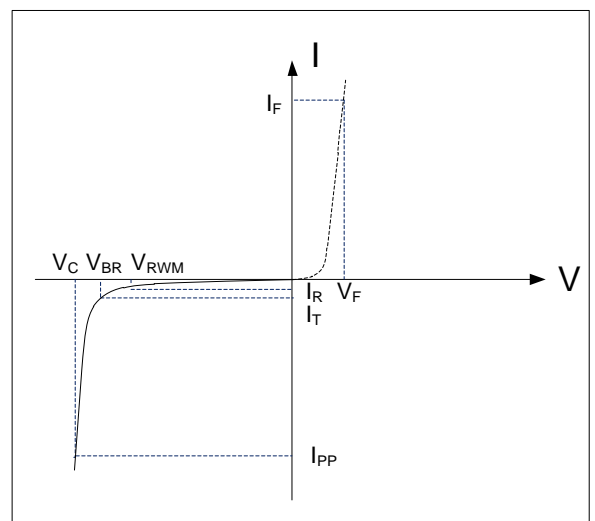

Note: 8/20 μs pulse waveform.

»TypicalCharacteristics

Figure 1: Peak Pulse Power vs. Pulse Time

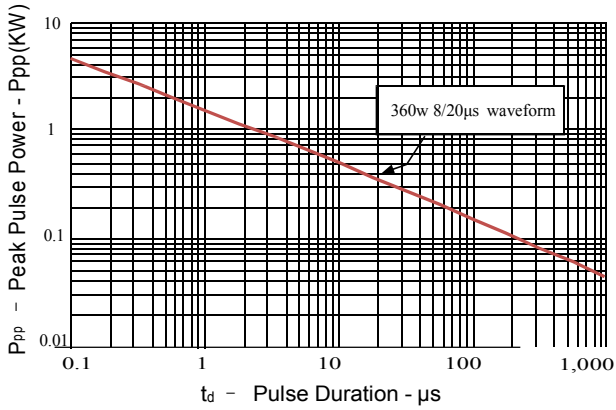

Figure 2: Power Derating Curve

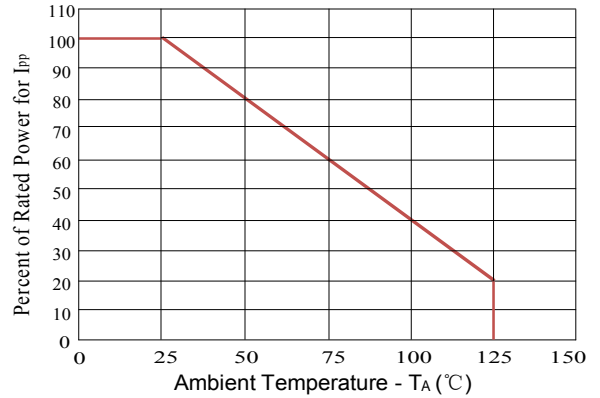

Figure3: Pulse Waveform

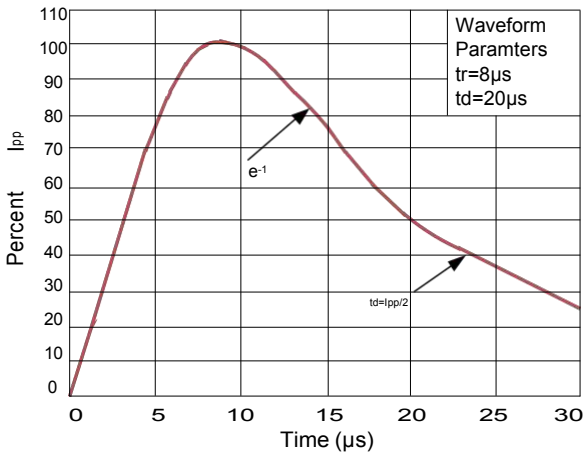

Figure 4: Clamping Voltage vs.Ipp

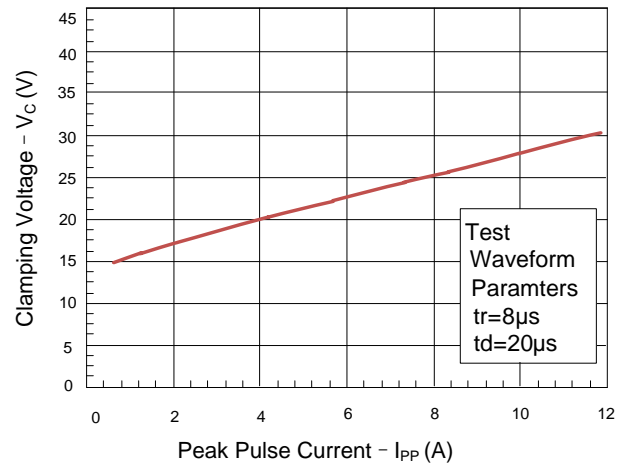
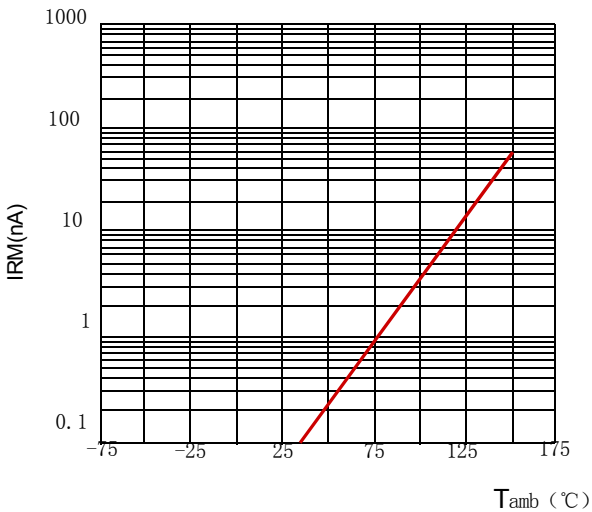
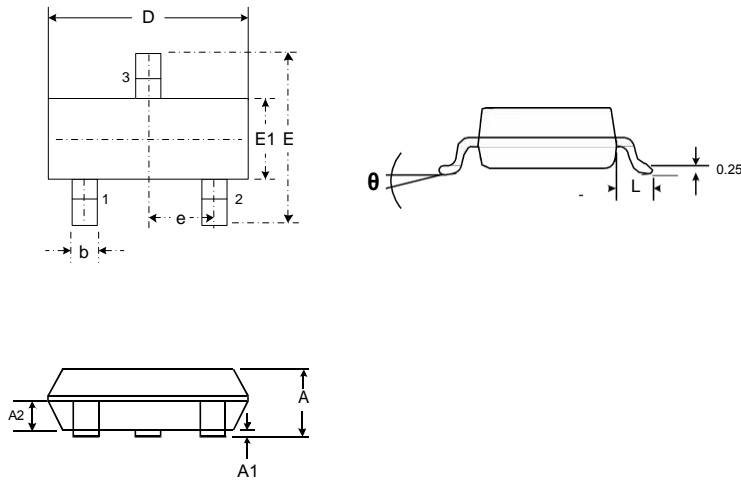

Figure 5: Peak Pulse Power Vs JunctionTemperature



»Outline Drawing – SOT23-3L



DIMENSIONS				
SYMBOL	MILLIMETER		INCHES	
	MIN	MAX	MIN	MAX
A	0.89	1.13	0.035	0.044
A1	0.015	0.11	0.0006	0.0043
A2	0.60	0.70	0.0236	0.0275
D	2.72	3.12	0.1070	0.1228
E	2.60	3.00	0.1024	0.118
E1	1.40	1.80	0.0551	0.0709
e	0.95 BSC		0.0374 BSC	
L	0.30	0.60	0.0118	0.0236
θ	0	8°	0	8°

»Ordering information

Order code	Package	Base qty	Delivery mode
ESDA14V2L	SOT23-3L	3k	Tape and reel