

»Features

- 70Watts peak pulse power ($t_p = 8/20\mu s$)
- Protect up to 2-lines
- Solid-state silicon-avalanche technology
- Low clamping voltage
- Low leakage current
- Low capacitance ($C_j = 0.28pF$ typ. I/O to I/O)
- IEC 61000-4-2 $\pm 8kV$ contact $\pm 15kV$ air
- IEC 61000-4-4 (EFT) 40A(5/50ns)
- IEC 61000-4-5 (Lightning) 3.5A (8/20 μs)



»Applications

- USB 2.0
- MMC Port
- Video Port
- Digital visual interface

»Mechanical Data

- DFN1109-6L package
- Molding compound flammability rating: UL 94V-0
- Packaging: Tape and Reel
- RoHS/WEEE Compliant

»Schematic & PIN Configuration

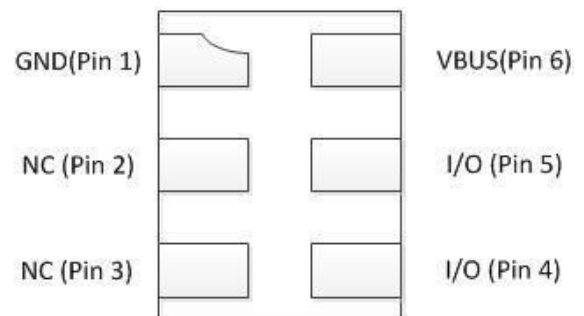
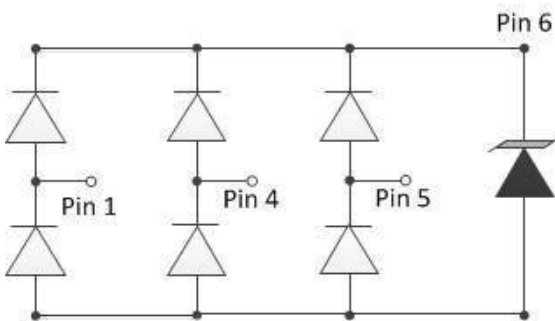

»Absolute Maximum Rating

Rating	Symbol	Value	Units
Peak Pulse Power ($t_p = 8/20\mu s$)	P_{PP}	70	Watts
Peak Pulse Current ($t_p = 8/20\mu s$)(note1)	I_{pp}	3.5	A
ESD per IEC 61000-4-2 (Air) ESD per IEC 61000-4-2 (Contact)	V_{ESD}	15 8	kV
Lead Soldering Temperature	T_L	260(10seconds)	°C
Junction Temperature	T_J	-55 to + 125	°C
Storage Temperature	T_{stg}	-55 to + 125	°C

»Electrical Characteristics

Parameter	Symbol	Conditions	Min	Typical	Max	Units
Reverse Stand-Off Voltage	V_{RWM}				5.0	V
Reverse Breakdown Voltage	V_{BR}	$I_T = 1mA$	6.0	7.2	9.5	V
Reverse Leakage Current	I_R	$V_{RWM} = 5V, T = 25^\circ C$		0.1	0.5	μA
Peak Pulse Current	I_{PP}	$t_p = 8/20\mu s$			3.5	A
Clamping Voltage	V_C	$I_{PP} = 3.5A, t_p = 8/20\mu s$			20	V
Junction Capacitance	C_j	$V_R = 0V, f = 1MHz$ I/O to I/O		0.28	0.4	pF
		$V_R = 0V, f = 1MHz$ I/O to GND		0.28	0.4	pF

»Electrical Parameters (TA = 25°C unless otherwise noted)

Symbol	Parameter
I_{PP}	Maximum Reverse Peak Pulse Current
V_C	Clamping Voltage @ I_{PP}
V_{RWM}	Working Peak Reverse Voltage
I_R	Maximum Reverse Leakage Current @ V_{RWM}
V_{BR}	Breakdown Voltage @ I_T
I_T	Test Current

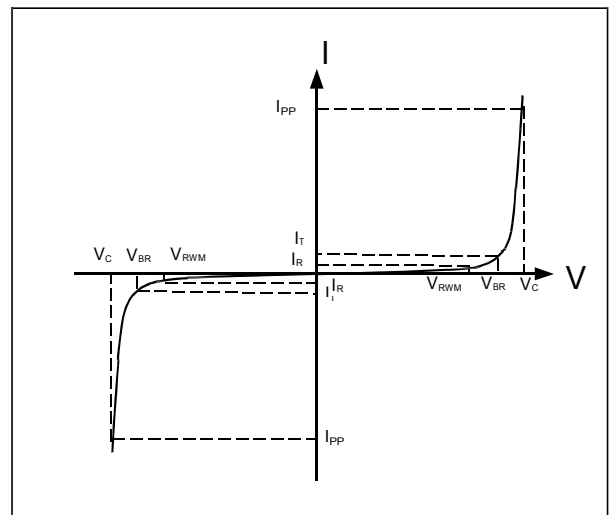

Note: 8/20 μs pulse waveform.

»TypicalCharacteristics

Fig.1 IEC61000-4-2Waveform

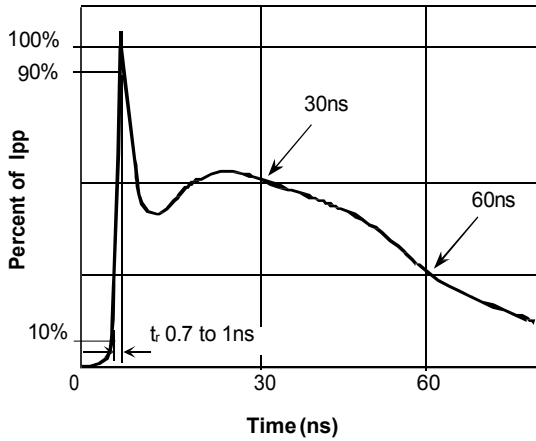

Fig.2 IEC61000-4-2 +8kV ContactESD ClampingWaveform

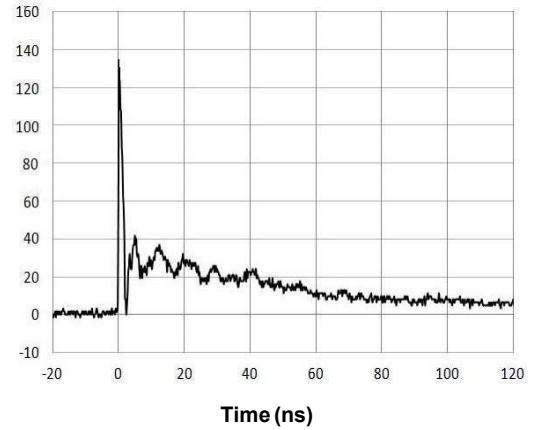

Fig.3 Eye Diagram - perchannel

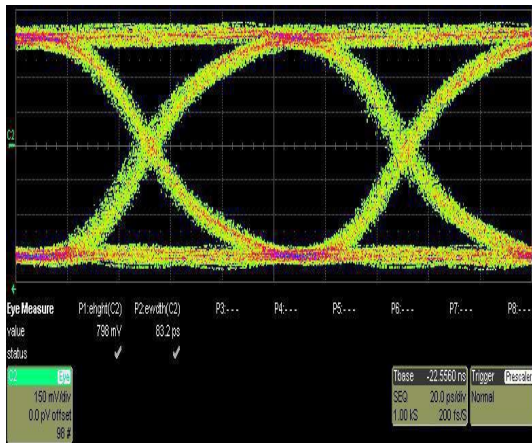
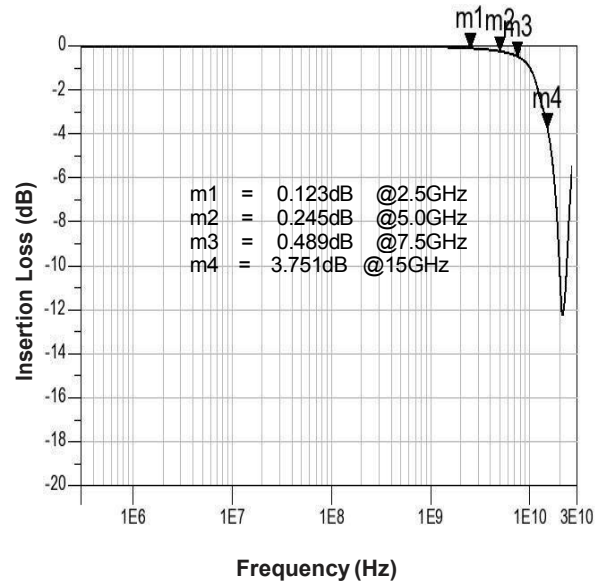
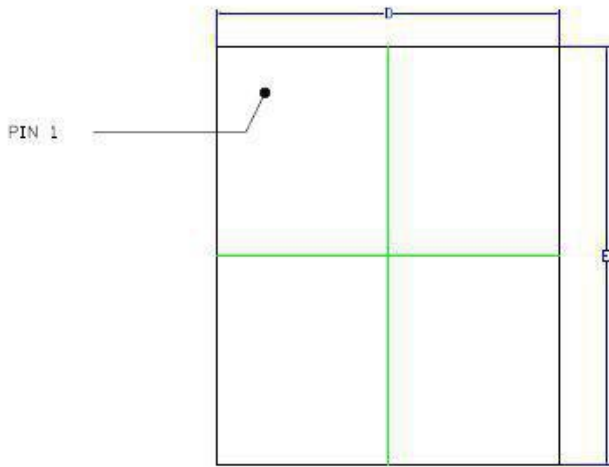

Fig.4 Insertion Loss S21 - I/O toI/O



»Outline Drawing – DFN1109



TOP VIEW

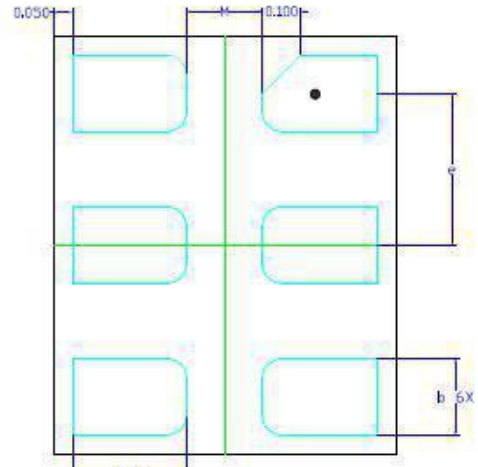

BOTTOM VIEW

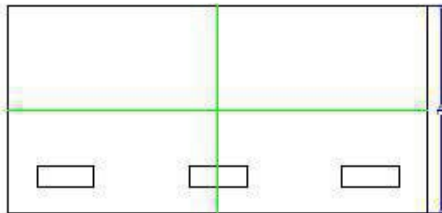

SIDE VIEW

COMMON DIMENSION (MM)			
PKG	DFN1109		
REF.	MIN.	NOM.	MAX
A	0,40	0,45	0,50
D	0,85	0,90	0,95
E	1,05	1,10	1,15
b	0,15	0,20	0,25
L	0,25	0,30	0,35
e	0,35	0,40	0,45
M	0,15	0,20	0,25

»Marking



»Ordering information

Order code	Package	Base qty	Delivery mode
RClamp0502N-N	DFN1109	3000	Tape and reel