



RoHS

MESSRS: _____

APPROVAL NO

730 - 001

DATE

2017.03.14

ALUMINUM ELECTROLYTIC

CAPACITOR

APPROVAL SHEET

CATALOG TYPE	NFA SERIES
USER PART NO.	
适用机种	
特记事项	Halogen-Free

QINGDAO SAMYOUNG ELECTRONICS CO.,LTD.

MANAGER OF DEVELOPMENT DEPARTMENT

GONG JANG SUG



USER APPROVAL:

APPROVAL NO.: _____

SamYoung(Korea) : 47,SAGIMAKGOL-RO,JUNGWON-GU,SEONGNAM-SI,GYEONGGI-DO,KOREA

SamYoung(China) : No.5 CHANGJIANG ROAD,PINGDU-CITY,SHANDONG-PROVINCE,CHINA



APPROVAL NO 730 - 001	ALUMINUM ELECTROLYTIC CAPACITOR	PAGE: 1 OF 5 DATE: 2017.03.14
---------------------------------	--	--

Specifications of NFA Series

Item	Characteristics															
Rated Voltage Range	160 ~ 400V _{DC}		420 ~ 500V _{DC}													
Operating Temperature Range	- 40 ~ + 105 °C		- 25 ~ + 105 °C													
Capacitance Tolerance	±20% <M> (at 20°C ,120Hz)															
Leakage Current (at 20 °C)	Where, I: Max. Leakage current (µA) C: Nominal capacitance(µF) V: Rated Voltage (V _{DC})		<table border="1"> <tr> <th colspan="2">After 1 minute</th> <th colspan="2">After 5 minutes</th> </tr> <tr> <th>C_RV_R≤1000</th> <th>C_RV_R>1000</th> <th>C_RV_R≤1000</th> <th>C_RV_R>1000</th> </tr> <tr> <td>0.1C_RV_R+40</td> <td>0.04C_RV_R+100</td> <td>0.03C_RV_R+15</td> <td>0.02C_RV_R+25</td> </tr> </table>		After 1 minute		After 5 minutes		C _R V _R ≤1000	C _R V _R >1000	C _R V _R ≤1000	C _R V _R >1000	0.1C _R V _R +40	0.04C _R V _R +100	0.03C _R V _R +15	0.02C _R V _R +25
	After 1 minute		After 5 minutes													
	C _R V _R ≤1000	C _R V _R >1000	C _R V _R ≤1000	C _R V _R >1000												
0.1C _R V _R +40	0.04C _R V _R +100	0.03C _R V _R +15	0.02C _R V _R +25													
Dissipation Factor (TAN δ) (at 20°C , 120Hz)	Rated voltage(V _{DC})	160 ~ 250	350 ~ 500													
	TANδ(Max.)	0.20	0.24													
Temperature Characteristic (Max.Impedance ratio)	Rated voltage(V _{DC})	160~250	350~400	420~500												
	Z-25°C/Z+20°C	3	5	6												
	Z-40°C/Z+20°C	6	6	-												
Load Life	The following specifications shall be satisfied when the capacitors are restored to 20°C after the rated voltage with the rated ripple current is applied(the peak voltage shall not exceed the rated voltage) at 105°C for 10,000 hours.(Where,4,000 hours for φ6.3: 7,000 hours for φ8: 8,000 hours for φ10.)															
	Capacitance change	: ≤± 20% of the initial Value														
	TANδ	: ≤200% of the initial specified value														
	LC	: ≤ The initial specified value														
Shelf Life	The following specifications shall be satisfied when the capacitors are restored to 20°C after exposing them for 1,000 hours at 105°C without voltage applied.The rated voltage shall be applied to the capacitor for a minimum of 30 minutes,at least 24 hours and not more than 48 hours before the measurements.															
	Capacitance change	: ≤± 20% of the initial Value														
	TANδ	: ≤200% of the initial specified value														
	LC	: ≤500% of the initial specified value														
Others	Satisfies characteristic KS C IEC 60384-4															

A.DIAGRAM OF DIMENSION

B.MARKING: DARK BROWN SLEEVE, SILVER INK

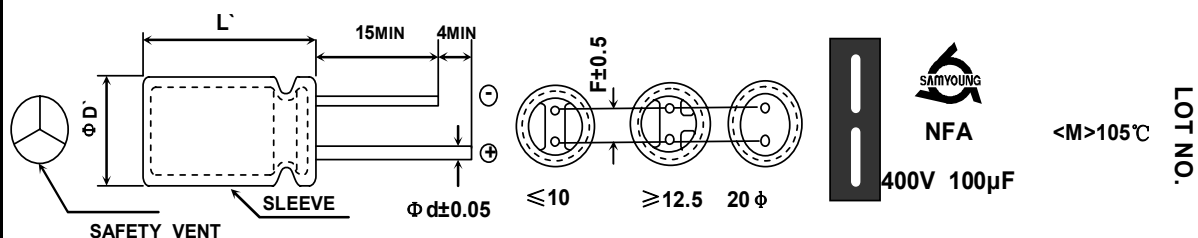

φ D	6.3	8	10	12.5	16	18	20	22
φ d	0.5	0.6	0.6	0.6	0.8	0.8	0.8	0.8
F	2.5	3.5	5.0	5.0	7.5	7.5	7.5	10
ΦD'	ΦD+0.5max							
L'	L+1.5max		L+2.0max					

FRONT VIEW OF CAPACITOR

BACK VIEW OF CAPACITOR

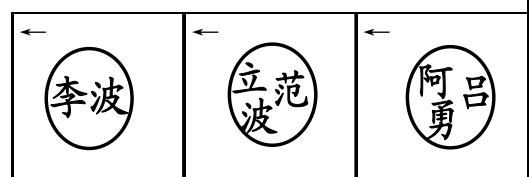

ALUMINUM ELECTROLYTIC CAPACITOR						APPROVAL NO 730 - 001		
RATINGS OF NFA Series								
Capacitance (uF)	160WV		200WV		250WV		350WV	
	Case size	Rated ripple current (mArms/105°C 120HZ)	Case size	Rated ripple current (mArms/105°C 120HZ)	Case size	Rated ripple current (mArms/105°C 120HZ)	Case size	Rated ripple current (mArms/105°C 120HZ)
	D×L		D×L		D×L		D×L	
1					6.3×11	20		
2.2					6.3×11	38		
3.3			8×11.5	42				
4.7			8×11.5	51	6.3×11	38		
6.8			6.3×11	45	8×11.5	64		
					8×11.5	64		
					8×11.5	94		
					10×12.5	100		
10	8×11.5	93	8×11.5	75	10×16	120		
			10×12.5	85	10×20	130	10×20	126
			10×12.5	109	10×12.5	110		
15								
18	8×15	139						
	8×15	139	10×16	150	10×16	178		
22	10×16	150						
	10×20	192	10×20	192	12.5×20	214	12.5×20	207
			10×20	236	10×20	230		
33	10×16	180	12.5×16	236				
	10×20	236	12.5×20	262	12.5×25	285	16×20	284
	10×16	226						
47	10×20	270			12.5×20	310		
	12.5×20	312	12.5×20	312	12.5×25	340	16×25	364
					12.5×20	335	16×20	284
					10×33	350		
			10×33	409				
68	10×20	380	12.5×20	360	16×20	420	16×31.5	472
	12.5×25	409	12.5×25	409	16×25	452	18×20	420
			16×20	386				
82	12.5×20	390	16×20	386				
	12.5×20	420			16×25	480	18×25	550
100	12.5×25	450	16×25	548	16×31.5	591	18×31.5	591
	16×25	548			18×20	452		
					12.5×40	590		
120					16×25	480		
			12.5×30	600	18×20	591	18×31.5	648
	16×20	550	16×25	548	12.5×50	700	18×31.5	724
					16×25	650		
150					16×35.5	670		
	16×31.5	724	16×31.5	701	18×25	700	18×40	760
					12.5×50	720		
200								
	16×25	813						
220	16×31.5	876	18×31.5	906	18×31.5	850	22×45	970
	16×31.5	876	18×31.5	906				
330	16×35.5	1110			20×40	1196		
	18×25	900						
	18×31.5	1110						
Capacitance (uF)	400WV		420WV		450WV		500WV	
	Case size	Rated ripple current (mArms/105°C 120HZ)	Case size	Rated ripple current (mArms/105°C 120HZ)	Case size	Rated ripple current (mArms/105°C 120HZ)	Case size	Rated ripple current (mArms/105°C 120HZ)
	D×L		D×L		D×L		D×L	
1	6.3×11	16			8×11.5	19		
1.5	6.3×11	20						
	8×11.5	22						
1.8	8×11.5	24						
2.2	6.3×11	16	8×11.5	25				
	8×11.5	27			10×12.5	48		
3.3	6.3×11	16	8×11.5	31	8×11.5	28		
					8×15	30		
	8×11.5	33			10×16	63		
4.7	8×11.5	39	8×11.5	37	10×12.5	67	10×16	55
	10×12.5	48			10×16	74		
6.8	10×12.5	66	8×20	76	10×12.5	81		
	10×16	77			10×16	87		
	8×15	63			10×20	96		
8.2	10×16	73	10×16	87				
	8×20	75			10×20	106		
			10×20	116	10×16	100		
10	10×16	85			10×20	108	12.5×20	120
	10×20	126			12.5×20	114		
	10×20	154	10×25	155	10×20	108		
15					10×25	119		
	12.5×16	150			12.5×20	114		
			12.5×20	191	12.5×20	150		
22	12.5×20	200			12.5×25	180	16×25	228
	16×20	232			16×20	205		
	12.5×25	225			16×25	241		
	16×20	284	16×20	262	12.5×30	315	16×25	228
33					16×20	262	18×25	260
					16×31.5	319		
					18×20	270		
39	16×20	284						
	12.5×30	284	16×25	335	16×25	350	18×31.5	393
47	16×25	364			18×20	300		
	18×20	355			18×25	368		
56			18×20	335	18×25	402	18×31.5	393
	16×25	400	18×25	435	16×31.5	430	16×45	625
68	16×31.5	472			18×25	435	18×31.5	400
	18×20	400			18×31.5	473	18×35.5	489
			16×31.5	507	16×35.5	450	18×40	550
82	18×25	501			18×31.5	509		
	18×31.5	536			18×35.5	537		
	12.5×50	480	18×31.5	580	18×31.5	570	20×40	510
100	18×25	501						
	18×31.5	570			18×35.5	590		
	18×35.5	611			18×40	602		
	18×31.5	600	18×31.5	580	18×31.5	570		
120					18×35.5	590		
	18×40	680	18×40	659	18×40	659		
	18×31.5	630	18×45	757				
150	18×35.5	748						
	18×40	760			20×40	757		
180	20×40	855			22×45	892		
220	22×45	996						

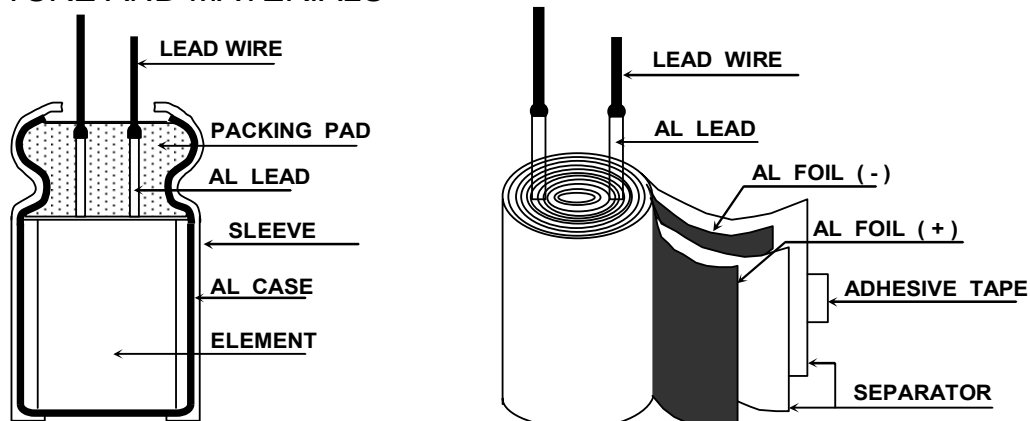

ALUMINUM ELECTROLYTIC CAPACITORS**APPROVAL NO.**
730 - 001**STRUCTURE AND MATERIALS**

CE04 TYPE

MINIATURE SIZED TYPE CAPACITORS COMPONENT

PART NAME	MATERIALS	VENDER
LEAD WIRE	TINNED COPPER - PLY WIRE(Pb-FREE)	KISTRON (KOREA/CHINA) KOHOKU (JAPAN/CHINA) NANTONG HONG YANG (CHINA)
AL LEAD	ALUMINUM 99.92 % OVER	KANG WON AUTO FITTING NAN TONG HUI FENG (CHINA) NANTONG HONG YANG KOHOKU (JAPAN/CHINA) KISTRON (KOREA/CHINA)
PACKING PAD	SYNTHETIC RUBBER	SUNG NAM (KOREA/CHINA) CCW/ZHE JIANG TIAN TAI ZHE JIANG TIAN HUA (CHINA)
SLEEVE	P.E.T(Poly Ethylene Terephthalate Resin)	MOO DEUNG (KOREA/CHINA) SUZHOU QILIAN SHUN PENG PLASTIC (CHINA) YUN LIN PLASTIC
AL CASE	ALUMINUM 99.0 % OVER	ZHANG JIA GANG LIAN YI LIN AN AO XING (CHINA) NANTONG CHUANGJIA DONG NAM (KOREA/CHINA) D.N TECH/HA NAM
AL FOIL ⊕	FORMED ALUMINUM 99.9 % OVER	K.D.K/JCC/MATSUSHITA (JAPAN) SAM YOUNG (KOREA) BECROMAL (ITALY) SATMA (FRANCE) HEC XINJIANG JOINWORLD (CHINA) HUAFENG / NANTONG / RAOIO LUXON/LITON (TAIWAN)
AL FOIL ⊖	ETCHED ALUMINUM 98.0 % OVER	K-JCC (KOREA) K.D.K (JAPAN) AFT/INCULCU/SHENGHONG ELECON/WU JIANG FEILO (CHINA)
SEPARATOR	INSULATION PAPER	KAN/LUNAN (CHINA) SPO (GERMANY) N.K.K (JAPAN)
ADHESIVE TAPE	POLY PROPYLENE OR POLY IMIDE FILM	NITTO/NICHIBAN (JAPAN) DAEIL/SWECO (KOREA)



When using aluminum electrolytic capacitors, pay strict attention to the following:

1. Electrolytic capacitors for DC application require polarization.

Confirm the polarity. If used in reversed polarity, the circuit life may be shortened or the capacitor may be damaged. For use on circuits whose polarity is occasionally reversed, or whose polarity is unknown, use bi-polarized capacitors (BP-series). Also, note that the electrolytic capacitor cannot be used for AC application.

2. Do not apply a voltage exceeding the capacitor's voltage rating.

If a voltage exceeding the capacitor's voltage rating is applied, the capacitor may be damaged as leakage current increases. When using the capacitor with AC voltage superimposed on DC voltage, care must be exercised that the peak value of AC voltage does not exceed the rated voltage.

3. Do not allow excessive ripple current to pass.

Use the electrolytic capacitor at current values within the permissible ripple range. If the ripple current exceeds the specified value, request capacitors for high ripple current applications.

4. Ascertain the operating temperature range.

Use the electrolytic capacitors according to the specified operating temperature range. Usage at room temperature will ensure longer life.

5. The electrolytic capacitor is not suitable for circuits in which charge and discharge are frequently repeated.

If used in circuits in which charge and discharge are frequently repeated, the capacitance value may drop, or the capacitor may be damaged. Please consult our engineering department for assistance in these applications.

6. Apply voltage treatment to the electrolytic capacitor which has been allowed to stand for a long time.

If the electrolytic capacitor is allowed to stand for a long time, its withstand voltage is liable to drop, resulting in increased leakage current. If the rated voltage is applied to such a product, a large leakage current occurs and this generates internal heat, which damaged the capacitor. If the electrolytic capacitor is allowed to stand for a long time, therefore, use it after giving voltage treatment (Note 1). (However, no voltage treatment is required if the electrolytic capacitor is allowed to stand for less than 2 or 3 years at normal temperature.)

7. Be careful of temperature and time when soldering.

When soldering a printed circuit board with various components, care must be taken that the soldering temperature is not too high and that the dipping time is not too long. Otherwise, there will be adverse effects on the electrical characteristics and insulation sleeve of electrolytic capacitors in the case of small-sized electrolytic capacitors, nothing abnormal will occur if dipping is performed at less than 260°C for less than 10 seconds.

8. Do not place a soldering iron on the body of the capacitor.

The electrolytic capacitor is covered with a vinyl sleeve. If the soldering iron comes in contact with the electrolytic capacitor body during wiring, damage to the vinyl sleeve and/or case may result in defective insulation, or improper protection of the capacitor element.

9. Cleaning circuit boards after soldering.

Some solvents have adverse effects on capacitors.

Please refer to the next page.

10. Do not apply excessive force to the lead wires or terminals.

If excessive force is applied to the lead wires and terminals, they may be broken or their connections with the internal elements may be affected. (For strength of terminals, refer to KS C IEC 60384-4 (JIS C5101-1, JIS C5101-4))

11. Care should be used in selecting a storage area.

If electrolytic capacitors are exposed to high temperatures caused by such things as direct sunlight, the life of the capacitor may be adversely affected. Storage in a high humidity atmosphere may affect the solderability of lead wires and terminals.

12. Surge voltage.

The surge voltage rating is the maximum DC over-voltage to which the capacitor may be subjected for short periods not exceeding approximately 30 seconds at infrequent intervals of not more than six minutes. According to KS C IEC 60384-4, the test shall be conducted 1000 cycles at room temperature for the capacitors of characteristic KS C IEC 60384-4 or at the maximum operating temperature for the capacitors of characteristics B and C of KS C IEC 60384-4 with voltage applied through a series resistance of 1000 ohms without discharge. The electrical characteristics of the capacitor after the test are specified in KS C IEC 60384-4. Unless otherwise specified, the rated surge voltage are as follows:

Rated Voltage(V)	2	4	6.3	10	16	25	35	50	63	80	100	160	200	250	315	350	400	450	500
Rated Surge Voltage(V)	2.5	5	8	13	20	32	44	63	79	100	125	200	250	300	365	400	450	500	550

Note 1 Voltage treatment ... Voltage treatment shall be performed by increasing voltage up to the capacitor's voltage rating gradually while lowering the leakage current. In this case, the impressed voltage shall be in the range where the leakage current of the electrolytic capacitor is less than specified value. Meanwhile, the voltage treatment time may be effectively shortened if the ambient temperature is increased (within the operating temperature range).

Note 2 For methods of testing, refer to KS C IEC 60384-4, (JIS C 5101-1, JIS C 5101-4)



CLEANING CONDITIONS

Aluminum electrolytic capacitors that have been exposed to halogenated hydrocarbon cleaning and defluxing solvents are susceptible to attack by these solvents. This exposure can result in solvent penetration into the capacitors, leading to internal corrosion and potential failure.

Common type of halogenated cleaning agents are listed below.

Chemical Name	Structural Formula	Representative Brand Name
Trichlorotrifluoroethane	C ₂ Cl ₃ F ₃	Freon TF, Daiflon S-3
Fluorotrichloromethane	CCl ₃ F	Freon-11, Daiflon S-1
1,1,1-Trichloroethane	F ₂ H ₃ Cl ₃	Chloroethane
Trichloroethylene	C ₂ HCl ₃	Trichiene
Methyl Chloride	CH ₃ Cl	MC

We would like to recommend you the below cleaning materials for your stable cleaning condition taking the place of previous materials.

◎ Isopropyl Alcohol (IPA) or Water

Cleaning method: One of immersion, ultrasonic or vapor cleaning.

Maximum cleaning time: 5 minutes (Chip type: 2 minutes)

※ Do not use AK225AES

Aluminum electrolytic capacitors are easily affected by halogen ions, particularly by chloride ions. Excessive amounts of halogen ions, if happened to enter the inside of the capacitors, will give corrosion accidents-rapid capacitance drop and vent open. The extent of corrosion accidents varies with kinds of electrolytes and seal-materials. Therefore, the prevention of halogen ion contamination is the most important check point for quality control in our production lines. At present, halogenated hydrocarbon-contained organic solvents such as Trichloroethylene, 1,1,1-Trichloroethane, and Freon are used to remove flux from circuit boards.

If electrolytic capacitors are cleaned with such solvents, they may gradually penetrate the seal portion and cause the corrosion. When using latex-based adhesive on the capacitors rubber end seal for adhesion to a PCB, corrosion may occur depending on the kind of solvent in the adhesive. Select an adhesive as an organic solvent with dissolved polymer that is not halogenated hydrocarbon. Hot air drying is required for eliminating the solvent between the product and the PCB at 50°C~80°C after coating.

Followings are the penetration path of the halogenated solvent.

- ① Penetration between the rubber and the aluminum case
- ② Penetration between the rubber and the lead wire
- ③ Penetration through the rubber

The inside of the capacitors, the mechanism of corrosion of aluminum electrolytic capacitors by halogen ions can be explained as follows:

Halides (RX) are absorbed and diffused into the seal portion. The halides then enter the inside of the capacitors and contact with the electrolyte of the capacitors. Whereby halogen ions are made free by a hydrolysis with water in the electrolyte:

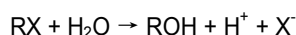

The halogen ions (X⁻) react with the dielectric substance (Al₂O₃) of aluminum electrolytic capacitors:

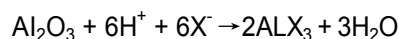

ALX₃ is dissociated with water:



※ MANUFACTURING SITE

- SamYoung Electronics Co., Ltd. (Korea/China)

