



SPECIFICATION FOR APPROVAL

CUSTOMER : _____

PRODUCT TYPE : HC-49/S SMD

NOMINAL FREQ. : 6.000000MHz

TXC P/N : 9C06000002

REVISION : A1

CUSTOMER P/N : _____

PM / SALES : _____

DATE : _____

CUSTOMER SIGNATURE & Date

- (1) TXC requires one copy returned with signature and title of authorized individual that signifies acceptance of the attached specifications.
- (2) Orders received and accepted by TXC after return of signed copy of specification will be produced per these specifications.
- (3) Any changes to these specifications must be agreed upon by both parties and new revision of the Product Specification Sheet will be issued.
- (4) Any issuance of purchase order prior to consigning back the Approval page of "Specification Sheets" from customers will be regarded as the agreement on the contents of these specifications.

Attachment: Product Specification Sheet

- 1
- 2
- 3
- 4
- 5

RoHS Compliant



PRODUCT SPECIFICATION SHEET

PRODUCT TYPE : HC-49/S SMD

NOMINAL FREQ. : 6.000000MHz

TXC P/N : 9C06000002

REVISION : A1

PE/RD	QA	MFG
<i>Simon Wang</i>	<i>Ton Hsieh</i>	<i>Shu-Chen Ko</i>
Simon Wang	Ton Hsieh	Shu-Chen Ko
2015/4/13	2015/4/13	2015/4/13

NOTE:

- (1) The green product standard set by TXC is based upon the international standards. Related information is publicly described on the TXC's Website, and updated regularly. The document is compliant with the latest green product quality system directives at the time.
- (2) Revision "Sx" is for engineering samples only. PE/RD's approval required.
- (3) Revision "Ax" is production ready. PE, QA and MFG's approval required.

RoHS Compliant

CONTENT

SPECIFICATIONS

PAGE

• ELECTRICAL SPECIFICATIONS	4
• DIMENSIONS	5
• SUGGESTED REFLOW PROFILE	5
• SUGGESTED MANUAL SOLDER CONDITION	5
• MARKING	6
• STRUCTURE ILLUSTRATION :	7
• EMBOSS CARRIER TAPE & REEL	8
• PACKING	8
• RELIABILITY SPECIFICATIONS	9 , 10

ATTACHMENT(S) (optional)

TESTING DATA

- | | | | |
|------------------------------------|---|------------------------------|--|
| • ELECTRICAL CHARACTERISTICS TEST | A | <input type="checkbox"/> YES | <input checked="" type="checkbox"/> NO |
| • TEMPERATURE CHARACTERISTICS TEST | B | <input type="checkbox"/> YES | <input checked="" type="checkbox"/> NO |

ELECTRICAL SPECIFICATIONS
Standard atmospheric conditions

Unless otherwise specified, the standard range of atmospheric conditions for making measurement and tests are as follow:

Ambient temperature : 25+/-5°C
 Relative humidity : 40%~70%

If there is any doubt about the results, measurement shall be made within the following limits:

Ambient temperature : 25+/-1°C
 Relative humidity : 40%~70%

Measure equipment

SAUNDERS 250A/250B CRYSTAL IMPEDANCE METER.

Crystal cutting type

The crystal is using AT CUT (thickness shear mode).

Unit Weight : 0.58 g +/- 0.05g

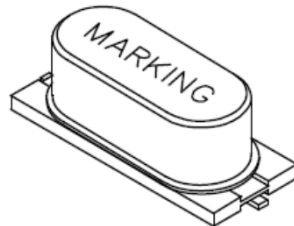

please refer to marking code page

	Parameters	SYM	Electrical				Notes
			MIN.	TYP.	MAX.	UNITS	
1	Nominal Frequency	FL	6.000000 MHz			MHz	
2	Oscillation Mode		Fundamental				
3	Load Capacitance	CL		20.0		pF	
4	Frequency Tolerance	FT	-30		+30	ppm	at 25 °C +/- 3 °C
5	Frequency Stability	ST	-30		+30	ppm	Over Operating Temp.Range
6	Operating Temperature	OT	-40		+85	°C	
7	Aging		-3		+3	ppm	1st year
8	Drive level	DL		100	1000	uW	
9	Effective Resistance Rr	Rr			80	ohm	
10	Shunt Capacitance	C0			7	pF	
11	Motional Capacitance	C1				fF	
12	Insulation Resistance		500			Mohm	at DC 100V
13	Storage Temperature Range		-40		+85	°C	
14	SPDB(+/-5000ppm)				-3.0	dB	

■ FACTORY LOCATION : CHINA

DIMENSIONS

UNIT:mm

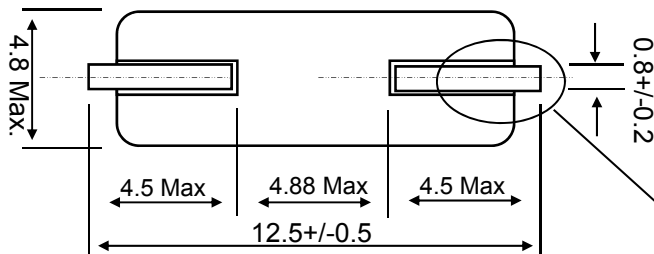
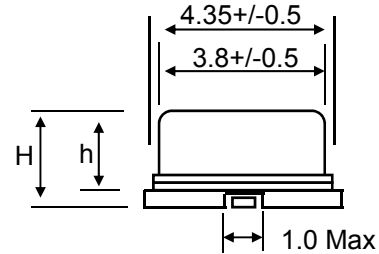
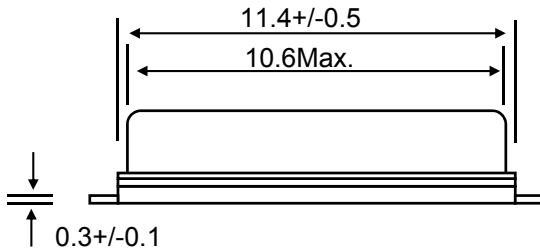

CHOOSE	TYPE	H(SMDHIGH)	h(BODY HIGH)
■	S3	3.8 +/- 0.3	3.3 +/- 0.3
□	S2	3.0 +/- 0.3	2.3 +/- 0.3

Solder Coating
(Sn-Ag-Cu Pb Free Coating)

Suggested Layout

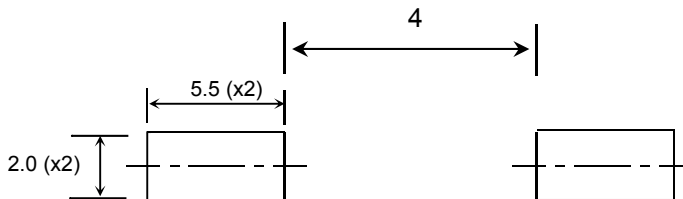

■ SUGGESTED REFLOW PROFILE

Solder melting point :220 +/- 10 °C, 60 sec. Min.
Peak Temperature: 260 +/- 5 °C, 10 sec. Max.

■ SUGGESTED MANUAL SOLDER CONDITI

Temperature: 350 +/- 10 °C
Time: 3 sec.
Re-solder times: twice

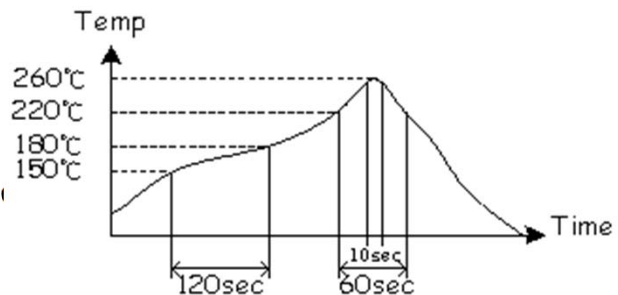

MARKING

Marking For Pb Free Parts :

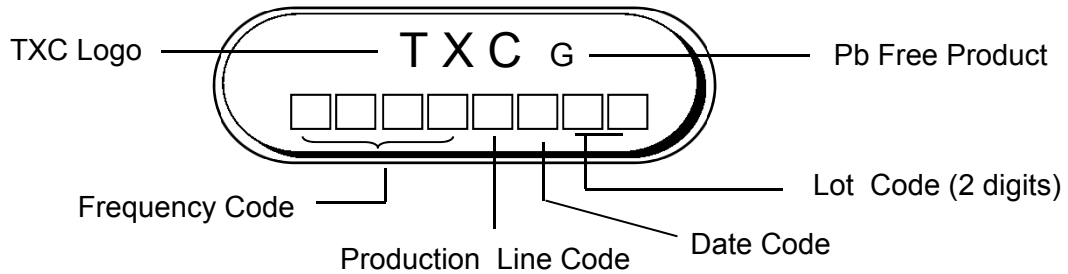

Date Code:

YEAR					MONTH											
					JAN	FEB	MAR	APR	MAY	JUN	JUL	AUG	SEP	OCT	NOV	DEC
2013	2017	2021	2025	2029	A	B	C	D	E	F	G	H	J	K	L	M
2014	2018	2022	2026	2030	N	P	Q	R	S	T	U	V	W	X	Y	Z
2015	2019	2023	2027	2031	a	b	c	d	e	f	g	h	j	k	l	m
2016	2020	2024	2028	2032	n	p	q	r	s	t	u	v	w	x	y	z

*This date code will be cycled every four years.

For example : Marking

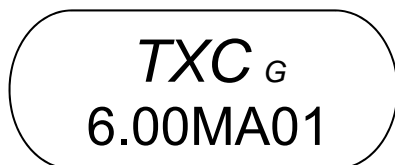

→
Introduction : Pb Free Product
49S 6.000 MHz
Made in NGB 2013/JAN 01Lot

STRUCTURE ILLUSTRATION :

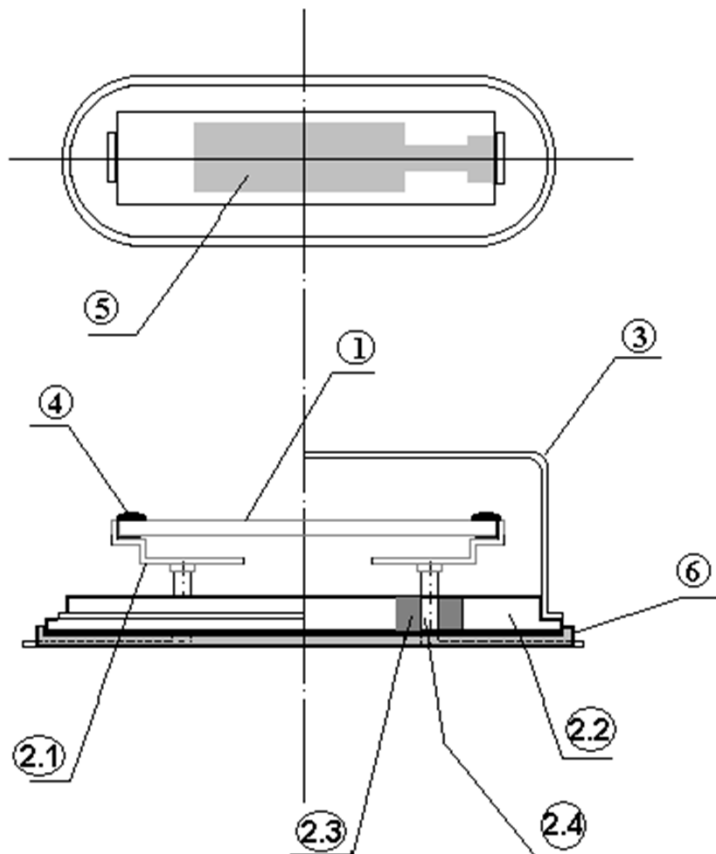

NO	COMPONENTS		MATERIALS	FINISH/SPECIFICATIONS
1	CRYSTAL BLANK		QUARTZ (SiO ₂)	/
2	2.1	CRYSTAL BASE	SUPPORTER	NICKEL SILVER
	2.2		HOLDER	SPCC
	2.3		GLASS	GLASS
	2.4		LEAD	KOVAR
				Ni PLATED+SOLDER DIPPED (Coating : Sn/Ag/Cu)
3	CRYSTAL COVER		NICKEL SILVER	Ni PLATED
4	CONDUCTIVE ADHESIVE		Ag + RESIN	/
5	ELECTRODE		Noble Metal	/
6	INSULATION PAD		PPS	/

(A) Tape and reel configuration:(Unit : mm)

(a) Emboss tapping configuration. (per EIA-481-2)

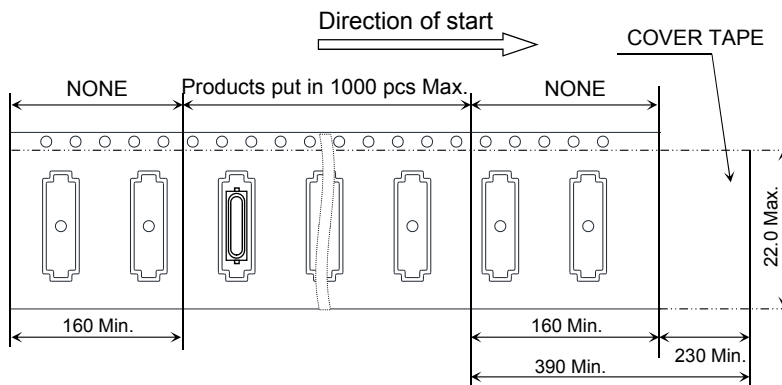
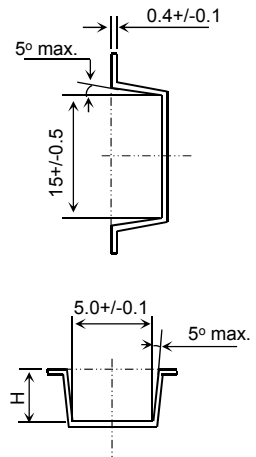
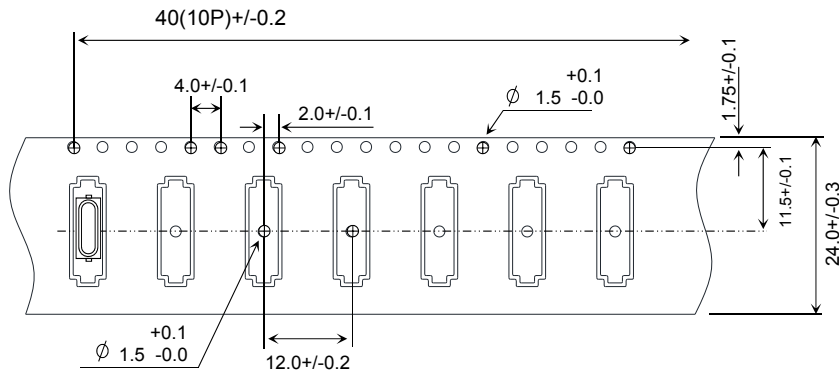

TYP.	H (+/-0.2)
S3	4.35
S2	3.5

(b) Reel configuration.

(B) Packing & Label :(Unit : mm)

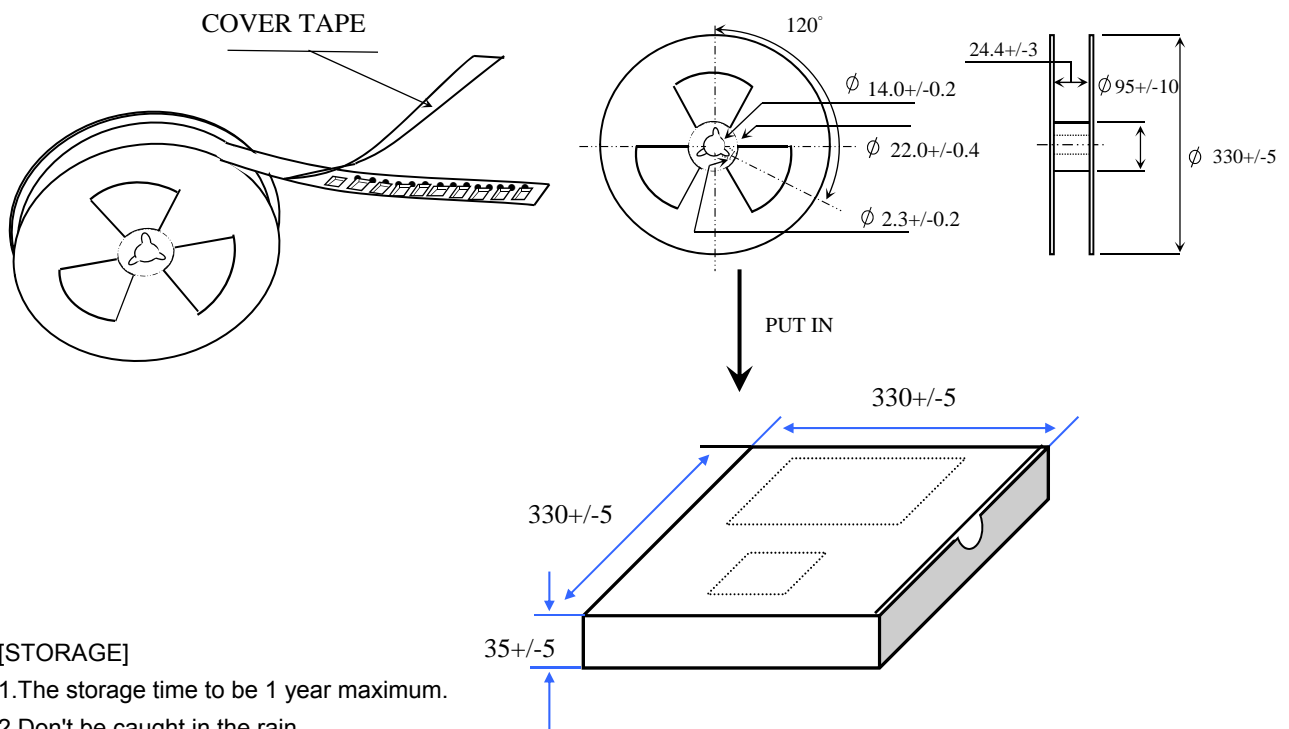

[STORAGE]

- 1.The storage time to be 1 year maximum.
- 2.Don't be caught in the rain.
- 3.The storage environment shall be 5°C ~40°C temperature and 30% ~ 75%RH humidity and free from the sun shine.
- 4.If customers have special requirements, we can paste labels according to it.

■ RELIABILITY SPECIFICATIONS

1.Mechanical Endurance

No.	Test Item	Test Methods	Test Criteria
1.1	Drop test	50 cm Height, Fall freely onto firm wood for 3 times.	B C
1.2	Mechanical Shock	1000 G , 0.5 m Sec. , 3 times for all 3 directions.	B C
1.3	Vibration	Frequency range 10 ~ 2000 Hz Acceleration 5G Sweep time 20 minute Pencil axes each test time 4 hours (Total test time 12 hours)	B C
1.4	Terminal Strength	17.7N force for 60sec +/-1sec.	F
1.5	Solderability	Pb free :Temperature 235+/-5°C,Immersion time:5+/-1sec	E
		Pb :Temperature 215+/-5°C,Immersion time:5+/-1sec	

2.Environmental Endurance

No.	Test Item	Test Methods	SPEC
2.1	Resistance To Soldering Heat	Test temperature 260 +/- 5 °C Test time 10 +/- 1 sec. Emersion Rate 25 +/- 6 mm/s Immersed of specimen 1.5mm	ACD
2.2	High Temp. Storage	+ 125°C +/- 3 °C for 500 +/- 12 Hrs	ACD
2.3	Low Temp. Storage	- 40 °C +/- 3 °C for 500 +/-12 Hrs	ACD
2.4	Temperature cycle	-40°C~125°C,for 300 cycles. 	ACD
2.5	High Temp & Humidity	85°C +/- 3°C , RH 85% , 500 Hrs	ACD

■ HANDING CAUTIONS

Prohibit the use of ultrasonic welding in Assembling

RELIABILITY SPECIFICATIONS

Specifications	
A	Frequency change: Within +/-20ppm or in customer's specification.
B	Frequency change: Within +/-10ppm or in customer's specification.
C	Equivalent series resistance(E.S.R) change: Within +/-15% or 10Ω(larger value).
D	After conditioning , quartz crystal units shall be subjected to standard atmospheric conditions for 24 hour, and measured.
E	Minimum 95% of immersed terminal shall be covered with new uniform solder.
F	No damage on specimen

Measurement condition

Measurements are carried out with Network-analyzer(S&A 250B or equivalent).