

-30V P-Channel Enhancement Mode MOSFET

$V_{DS} = -30V$

$R_{DS(ON)}, V_{GS}@-10V, I_{DS}@ -4.1A < 80m\Omega$

$R_{DS(ON)}, V_{GS}@-4.5V, I_{DS}@-3.0A < 110m\Omega$

Features

Advanced trench process technology

High Density Cell Design For Ultra Low On-Resistance

Package Dimensions

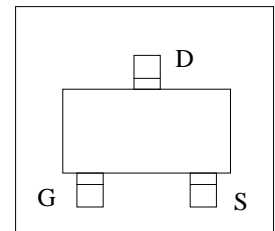
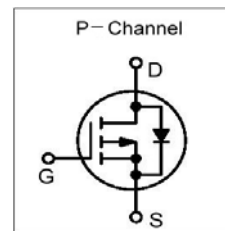
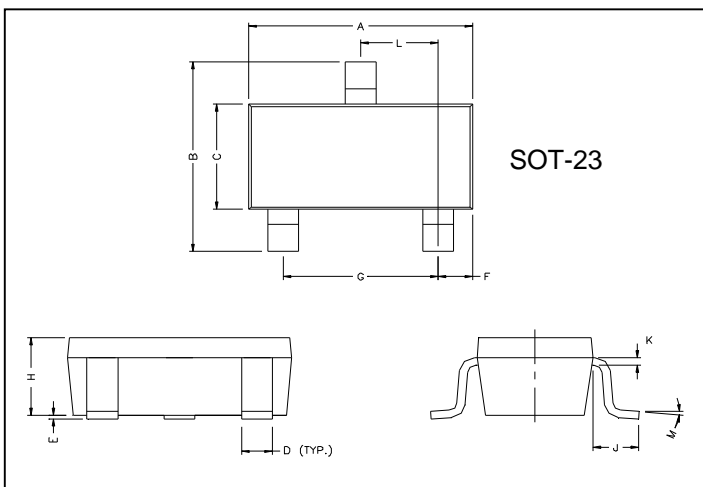

REF.	Millimeter		REF.	Millimete	
	Min.	Max.		Min.	Max.
A	2.80	3.00	G	1.80	2.00
B	2.30	2.50	H	0.90	1.1
C	1.20	1.40	K	0.10	0.20
D	0.30	0.50	J	0.35	0.70
E	0	0.10	L	0.92	0.98
F	0.45	0.55	M	0°	10°

Maximum Ratings and Thermal Characteristics (TA = 25°C unless otherwise noted)

Parameter	Symbol	Limit	Unit	
Drain-Source Voltage	V_{DS}	-30	V	
Gate-Source Voltage	V_{GS}	± 20		
Continuous Drain Current	I_D	-4.1	A	
Pulsed Drain Current	I_{DM}	-20		
Maximum Power Dissipation	P_D	TA = 25°C	1.4	W
		TA = 75°C	1	
Operating Junction and Storage Temperature Range	T_J, T_{stg}	-55 to 150	°C	
Junction-to-Ambient Thermal Resistance (PCB mounted)	$R_{\theta JA}$	125	°C/W	

ELECTRICAL CHARACTERISTICS (TA = 25oC unless otherwise noted)

Parameter	Symbol	Test Condition	Min.	Typ.	Max.	Unit
Static						
Drain-Source Breakdown Voltage	BV_{DSS}	$V_{GS} = 0V, I_D = -250\mu A$	-30			V
Drain-Source On-State Resistance	$R_{DS(on)}$	$V_{GS} = -10V, I_D = -4.1A$		48.0	80	mΩ
Drain-Source On-State Resistance	$R_{DS(on)}$	$V_{GS} = -4.5V, I_D = -3A$		64.0	110	
Gate Threshold Voltage	$V_{GS(th)}$	$V_{DS} = V_{GS}, I_D = -250\mu A$	-1.0	-1	-3.0	V
Zero Gate Voltage Drain Current	I_{DSS}	$V_{DS} = -24V, V_{GS} = 0V$			-1	uA
Gate Body Leakage	I_{GSS}	$V_{GS} = 20V, V_{DS} = 0V$			100	nA
Forward Transconductance	g_{fs}	$V_{DS} \pm 5V, I_D = -4A$	5.5		—	S
Dynamic						
Total Gate Charge	Q_g	$V_{DS} = -15V, I_D = -4.1A$ $V_{GS} = -10V$		9.35		nC
Gate-Source Charge	Q_{gs}			3.43		
Gate-Drain Charge	Q_{gd}			1.7		
Turn-On Delay Time	$t_{d(on)}$	$V_{DD} = -15V, R_L = 15\Omega$ $I_D = -1A, V_{GEN} = -10V$ $R_G = 6\Omega$		10.8		ns
Turn-On Rise Time	t_r			2.33		
Turn-Off Delay Time	$t_{d(off)}$			22.53		
Turn-Off Fall Time	t_f			3.87		
Input Capacitance	C_{iss}	$V_{DS} = -15V, V_{GS} = 0V$ $f = 1.0\text{ MHz}$		551.57		pF
Output Capacitance	C_{oss}			90.96		
Reverse Transfer Capacitance	C_{rss}			60.79		
Source-Drain Diode						
Max. Diode Forward Current	I_S				-2.6	A
Diode Forward Voltage	V_{SD}	$I_S = 2.6A, V_{GS} = 0V$			-1.3	V

Note: Pulse test: pulse width <= 300us, duty cycle <= 2%

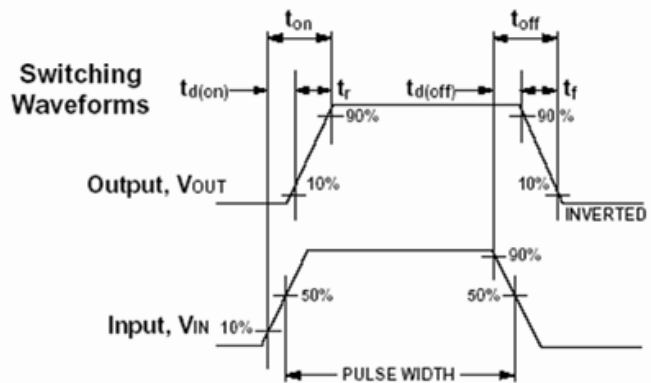
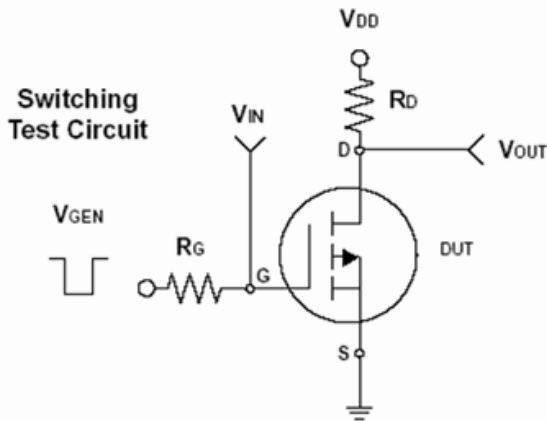

Typical Characteristics (T_J = 25°C Noted)

