

20V Dual N-Channel Enhancement Mode MOSFET

VDS= 20V

RDS(ON), Vgs @ 2.5V, Ids @ 5.2A = 24mΩ

RDS(ON), Vgs @ 4.5V, Ids @ 6A = 20mΩ

Features

- Advanced trench process technology
- High Density Cell Design For Ultra Low On-Resistance
- High Power and Current handling capability
- Ideal for Li ion battery pack applications

Package Dimensions

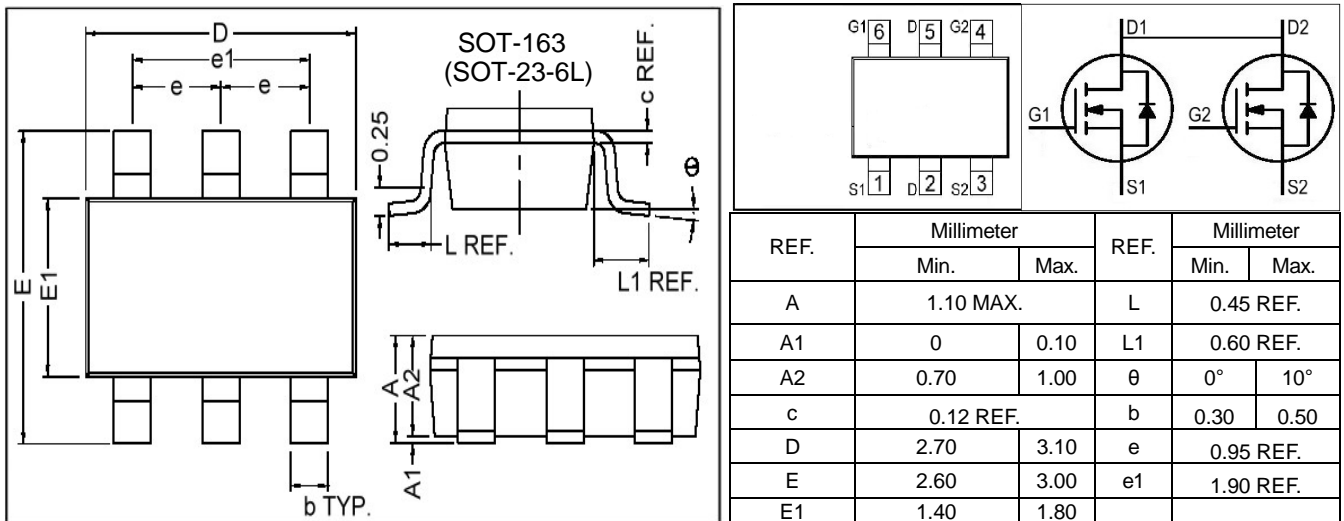

Maximum Ratings and Thermal Characteristics (TA = 25°C unless otherwise noted)

Parameter	Symbol	Limit	Unit	
Drain-Source Voltage	V _{DS}	20	V	
Gate-Source Voltage	V _{GS}	± 12		
Continuous Drain Current	I _D	6	A	
Pulsed Drain Current ¹⁾	I _{DM}	25		
Maximum Power Dissipation	P _D	TA = 25°C	1.4	W
		TA = 75°C	1	
Operating Junction and Storage Temperature Range	T _J , T _{stg}	-55 to 150	°C	
Junction-to-Ambient Thermal Resistance (PCB mounted) ²⁾	R _{θJA}	100	°C/W	

Notes

- Pulse width limited by maximum junction temperature.
- Surface Mounted on FR4 Board, t ≤ 5 sec.

20V Dual N-Channel Enhancement Mode MOSFET

ELECTRICAL CHARACTERISTICS

Parameter	Symbol	Test Condition	Min.	Typ.	Max.	Unit
Static						
Drain-Source Breakdown Voltage	BV_{DSS}	$V_{GS} = 0V, I_D = 250\mu A$	20	-	-	V
Drain-Source On-State Resistance ¹⁾	$R_{DS(on)}$	$V_{GS} = 2.5V, I_D = 5.2A$		24.0	32	mΩ
Drain-Source On-State Resistance ¹⁾	$R_{DS(on)}$	$V_{GS} = 4.5V, I_D = 6A$		20.0	25	
Gate Threshold Voltage	$V_{GS(th)}$	$V_{DS} = V_{GS}, I_D = 250\mu A$	0.6		1.5	V
Zero Gate Voltage Drain Current 0	I_{DSS}	$V_{DS} = 16V, V_{GS} = 0V$			1	μA
Gate Body Leakage	I_{GSS}	$V_{GS} = \pm 12V, V_{DS} = 0V$			±100	nA
Forward Transconductance	g_{fs}	$V_{DS} = 5V, I_D = 6A$		22	—	S
Dynamic¹⁾						
Total Gate Charge	Q_g	$V_{DS} = 10V, I_D = 6A$ $V_{GS} = 4.5V$		5		nC
Gate-Source Charge	Q_{gs}			1.1		
Gate-Drain Charge	Q_{gd}			2.1		
Turn-On Delay Time	$t_{d(on)}$	$V_{DD} = 10V, R_G = 6\Omega$ $I_D = 1A, V_{GS} = 4.5V$		10		ns
Turn-On Rise Time	t_r			11		
Turn-Off Delay Time	$t_{d(off)}$			35		
Turn-Off Fall Time	t_f			30		
Input Capacitance	C_{iss}	$V_{DS} = 8V, V_{GS} = 0V$ $f = 1.0\text{ MHz}$		600		pF
Output Capacitance	C_{oss}			330		
Reverse Transfer Capacitance	C_{rss}			140		
Source-Drain Diode						
Max. Diode Forward Current	I_S				1.7	A
Diode Forward Voltage	V_{SD}	$I_S = 1.7A, V_{GS} = 0V$		0.72	1.2	V

¹⁾ Pulse test: pulse width ≤ 300μs, duty cycle ≤ 2%

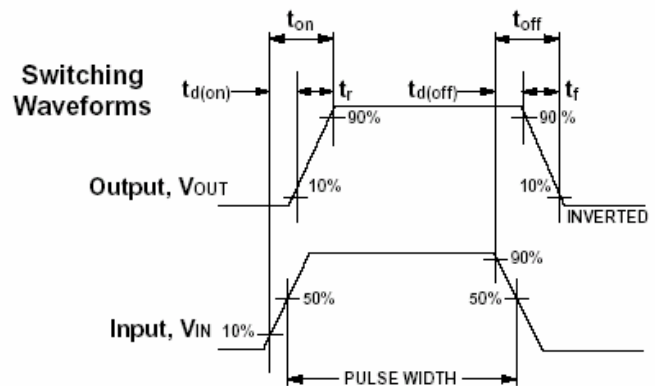
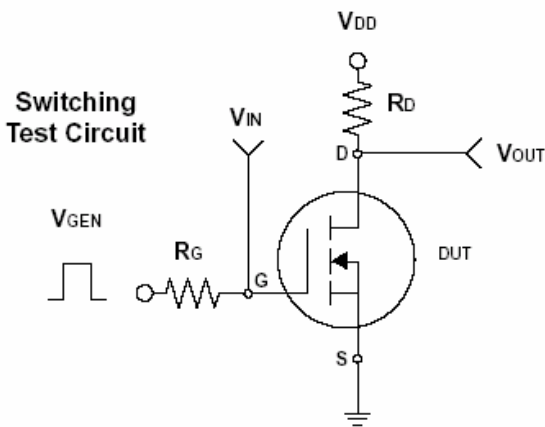

20V Dual N-Channel Enhancement Mode MOSFET

Typical Characteristics (T_J = 25°C Noted)

