

-30V P-Channel Enhancement Mode MOSFET

VDS= -30V

RDS(ON), Vgs@-10V, Ids@-10.5A = 18mΩ

RDS(ON), Vgs@-4.5V, Ids@-6.0A = 30mΩ

Features

Advanced trench process technology

High Density Cell Design For Ultra Low On-Resistance

Package Dimensions

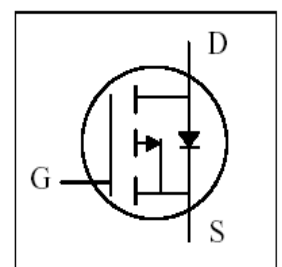
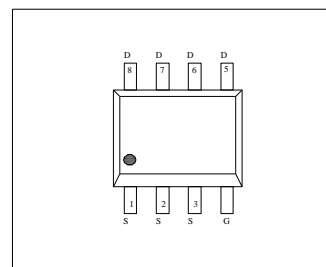
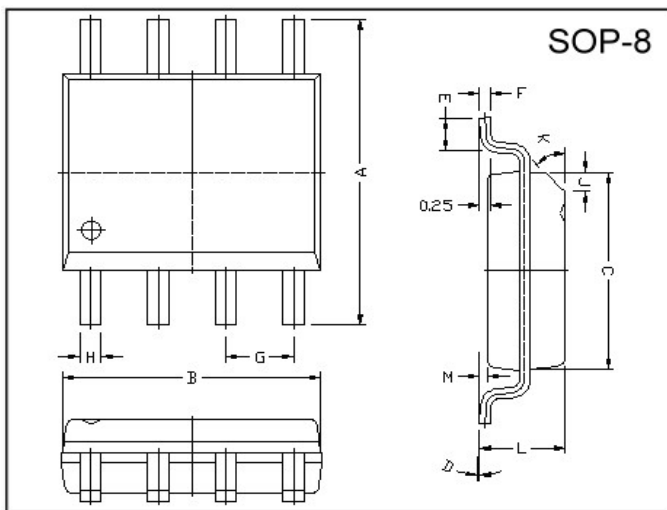

REF.	Millimeter		REF.	Millimeter	
	Min.	Max.		Min.	Max.
A	5.80	6.20	M	0.10	0.25
B	4.80	5.00	H	0.35	0.49
C	3.80	4.00	L	1.35	1.75
D	0°	8°	J	0.375 REF.	
E	0.40	0.90	K	45°	
F	0.19	0.25	G	1.27 TYP.	

Maximum Ratings and Thermal Characteristics (TA = 25oC unless otherwise noted)

Parameter	Symbol	Limit	Unit	
Drain-Source Voltage	V _{DS}	-30	V	
Gate-Source Voltage	V _{GS}	± 20		
Continuous Drain Current	I _D	-10.5	A	
Pulsed Drain Current	I _{DM}	-50		
Maximum Power Dissipation	P _D	TA = 25°C	2.5	W
		TA = 75°C	1.2	
Operating Junction and Storage Temperature Range	T _J , T _{stg}	-55 to 150	°C	
Junction-to-Ambient Thermal Resistance (PCB mounted)	R _{θJA}	50	°C/W	

ELECTRICAL CHARACTERISTICS

Parameter	Symbol	Test Condition	Min.	Typ.	Max.	Unit
Static						
Drain-Source Breakdown Voltage	BV_{DSS}	$V_{GS} = 0V, I_D = -250\mu A$	-30			V
Drain-Source On-State Resistance	$R_{DS(on)}$	$V_{GS} = -10V, I_D = -10.5A$		15.0	22.0	mΩ
Drain-Source On-State Resistance	$R_{DS(on)}$	$V_{GS} = -4.5V, I_D = -6.0A$		20.0	33.0	
Gate Threshold Voltage	$V_{GS(th)}$	$V_{DS} = V_{GS}, I_D = -250\mu A$	-1	-1.4	-3	V
Zero Gate Voltage Drain Current	I_{DSS}	$V_{DS} = -24V, V_{GS} = 0V$			-1	uA
Gate Body Leakage	I_{GSS}	$V_{GS} = \pm 20V, V_{DS} = 0V$			± 100	nA
Forward Transconductance	g_{fs}	$V_{DS} = -10V, I_D = -5A$		21	—	S
Dynamic						
Total Gate Charge	Q_g	$V_{DS} = -15V, I_D = -9.1A$ $V_{GS} = 10V$		37.2		nC
Gate-Source Charge	Q_{gs}			9.84		
Gate-Drain Charge	Q_{gd}			7.52		
Turn-On Delay Time	$t_{d(on)}$	$V_{DD} = -15V, R_L = 15\Omega$ $I_D = -1A, V_{GEN} = -10V$ $R_G = 6\Omega$		10		ns
Turn-On Rise Time	t_r			15		
Turn-Off Delay Time	$t_{d(off)}$			110		
Turn-Off Fall Time	t_f			70		
Input Capacitance	C_{iss}	$V_{DS} = 8V, V_{GS} = 0V$ $f = 1.0\text{ MHz}$		1740		pF
Output Capacitance	C_{oss}			235		
Reverse Transfer Capacitance	C_{rss}			225		
Source-Drain Diode						
Diode Forward Voltage	V_{SD}	$I_S = -2.1A, V_{GS} = 0V$		1.2		V

Note: Pulse test: pulse width ≤ 300us, duty cycle ≤ 2%

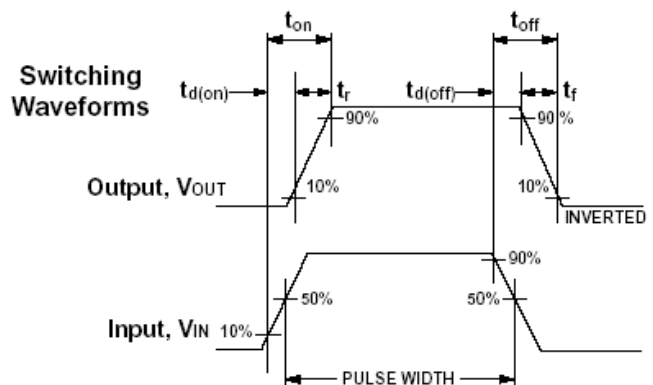
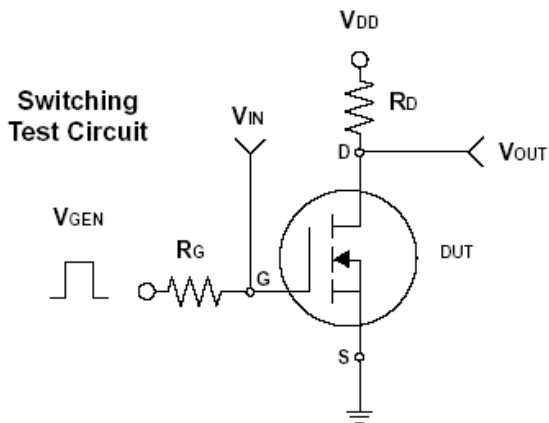

Typical Characteristics (T_J = 25°C Noted)

