



一、电性能参数 ELECTRICAL PARAMETERS:

No.	特性 Characteristic	范围 Limits	备注 Remark
1	产品型号 Ackage Type	HC-49SMB	
2	标称频率 Nominal Frequency	16.000000MHz	
3	振动模式 Mode of Vibration	AT—Fund (基频)	
4	常温频差 Frequency Tolerance	±20ppm	25±3℃ 测试 Measure at 25℃±3℃
5	工作温度范围 Operating Temperature Range	-40℃~+85℃	
6	频率稳定度 Frequency Stability	±50ppm	
7	储存温度范围 Storage Temperature Range	-40℃~+85℃	
8	负载电容 Load capacitance	12pF	
9	谐振电阻 Equivalent Series Resistance	40 Ω max	
10	激励功率 Drive Level	50 μ W (1000 μ W max)	
11	绝缘电阻 Insulation Resistance	500M Ω	At 250V _{DC}
12	静电容 Shunt Capacitance	5pF max	
13	老化率 Aging Per Year	±5ppm	
14			
15			
16			
17			
18			



二、可靠性试验 Reliability test

No.	测试项目 Item	测试条件 Test Conditions	判定标准 Basis of Verdict
1	跌落冲击 Drop	75cm 高度自由下落到 3cm 厚度的硬质木板 3 次 3 Times Free Fall from 75cm height table to 3cm thickness hard wood board	$\Delta FL \leq \pm 5\text{ppm}$, $\Delta R \leq 5\text{ohm or } \leq 10\%$
2	模拟回流焊 Reflow	$240^{\circ}\text{C} \leq T \leq 265^{\circ}\text{C}$ $t=60 \pm 30\text{s}$ $T=260^{\circ}\text{C} \pm 5^{\circ}\text{C}$ $t=40 \pm 10\text{s}$ $T(\text{max})= 265^{\circ}\text{C}$	$\Delta FL \leq \pm 5\text{ppm}$, $\Delta R \leq 5\text{ohm or } \leq 10\%$
3	可焊性 Solder	$260^{\circ}\text{C} \pm 5^{\circ}\text{C}$ 焊锡槽浸润 3 ± 0.5 秒 Temperature: $260^{\circ}\text{C} \pm 5^{\circ}\text{C}$ Time: 3 ± 0.5 Seconds	新锡覆盖率 $\geq 90\%$ the solder immersion surface $\geq 90\%$
4	耐焊接热 Solder Heating	$280^{\circ}\text{C} \pm 5^{\circ}\text{C}$ 焊锡槽浸润 10 ± 1 秒 Temperature: $280^{\circ}\text{C} \pm 5^{\circ}\text{C}$ Time: 10 ± 1 Seconds	$\Delta FL \leq \pm 5\text{ppm}$, $\Delta R \leq 5\text{ohm or } \leq 10\%$
5	气密性 Leakage	$4 \sim 5\text{Kg/cm}^2$ 压力之氦气罐中加压 10 ± 1 分钟 He Pressure: $4 \sim 5\text{Kg/cm}^2$ Time: 10 ± 1 min	$\leq 3 \times 10^{-9} \text{Pa} \cdot \text{m}^3/\text{s}$
6	高温储存 High temperature storage	$100^{\circ}\text{C} \pm 2^{\circ}\text{C}$ 烘箱中烘烤 96 ± 1 小时 Temperature: $100^{\circ}\text{C} \pm 5^{\circ}\text{C}$ Time: 96 ± 1 Hours	$\Delta FL \leq \pm 5\text{ppm}$, $\Delta R \leq 5\text{ohm or } \leq 10\%$
7	高温老化 High temperature ageing	$85^{\circ}\text{C} \pm 5^{\circ}\text{C}$ 之烘箱中烘烤 30 天 Temperature: $85^{\circ}\text{C} \pm 5^{\circ}\text{C}$ Time: 30 days	$\Delta FL \leq \pm 5\text{ppm}$, $\Delta R \leq 5\text{ohm or } \leq 10\%$
8	低温储存 Low temperature storage	$-40^{\circ}\text{C} \pm 2^{\circ}\text{C}$ 环境中保持 96 ± 1 小时 Temperature: $-40^{\circ}\text{C} \pm 2^{\circ}\text{C}$ Time: 96 ± 1 Hours	$\Delta FL \leq \pm 5\text{ppm}$, $\Delta R \leq 5\text{ohm or } \leq 10\%$
9	恒温恒湿 Humidity	在湿度为 $90 \sim 95\%$, 温度为 $40 \pm 2^{\circ}\text{C}$ 环境中保持 96 小时 Temp: $40^{\circ}\text{C} \pm 2^{\circ}\text{C}$ Humidity: $90 \sim 95\%$ Times: 96 Hours	$\Delta FL \leq \pm 5\text{ppm}$, $\Delta R \leq 5\text{ohm or } \leq 10\%$
10	热冲击 Thermal Shock	-40°C 和 $+85^{\circ}\text{C}$, 各 30 ± 1 分钟, 循环 10 次 Temperature: $-40^{\circ}\text{C} \pm 2^{\circ}\text{C} \leftrightarrow 85^{\circ}\text{C} \pm 2^{\circ}\text{C}$ Time: 30 ± 1 min For 10 cycles	$\Delta FL \leq \pm 5\text{ppm}$, $\Delta R \leq 5\text{ohm or } \leq 10\%$

No.	测试项目 Item	测试条件 Test Conditions	判定标准 Basis of Verdict
11	振动 Vibration	频率: 10~50Hz, 幅度: 0.75mm 频率: 50Hz~500Hz, 加速度幅度: 98m/s ² 周期: 10-500-10Hz, 15min 振动方向: X、Y、Z 振动时间: 每个方向 2 小时 Frequency: 10~50Hz, Amplitude: 0.75mm Frequency: 50~500Hz, Amplitude: 98m/s ² Cycle time: 10-500-10H, 15min Direction: X、Y、Z Duration: 2 Hours /direction	$\Delta FL \leq \pm 5\text{ppm}$, $\Delta R \leq 50\text{ohm or } \leq 10\%$
12	端子拉力强度 Tensile Strength	在每个端子上, 沿端子轴方向施力 900g 的拉力 30±5 秒 Apply a 900g tensile load to each terminal and sustain it for 30s±5s	晶体无损伤 without distinct damage

三、外形尺寸 Outline Dimensions (unit: mm)

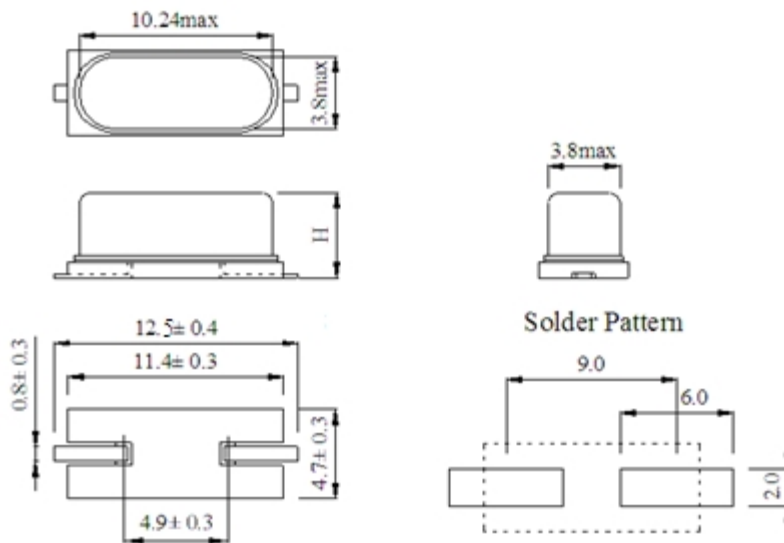

Part	H
HC-49SMA	4.2mm Max
HC-49SMB	3.2mm Max

四、印字 Marking

由 7 位组成, 前 6 位: 频率 Mhz/7 Digitals, First 6 Digitals: Frequency in Mhz

最后 1 位: 公司代码/End 1 Digitals: company ID

H=固定代码 Y=年份 (2018=8, 2019=9) M=月份 (A=1 月份, B=2 月份.....M=12 月份)

当前字样:

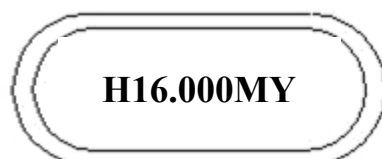

五、包装方式 Packing

T/R: 1000pcs/ REEL

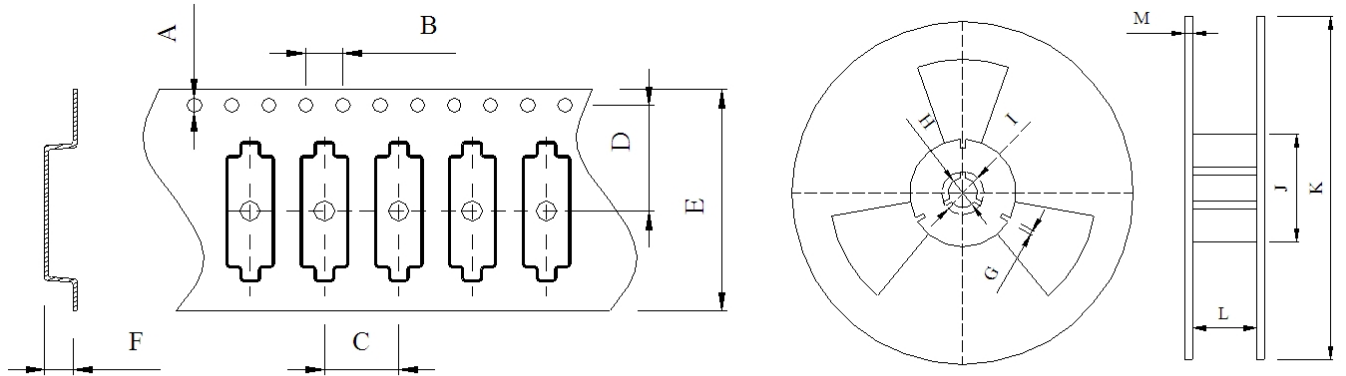

单位 units : mm:

Model	A	B	C	D	E	F	G	H	I	J	K	L	M
HC-49SMA	Φ1.50	4.0	12.0	11.5	24.0	4.35	2.5	Φ13.5	21.6	99.5	330	24.0	2.3
HC-49SMB	Φ1.50	4.0	12.0	11.5	24.0	3.5	2.5	Φ13.5	21.6	99.5	330	24.0	2.3

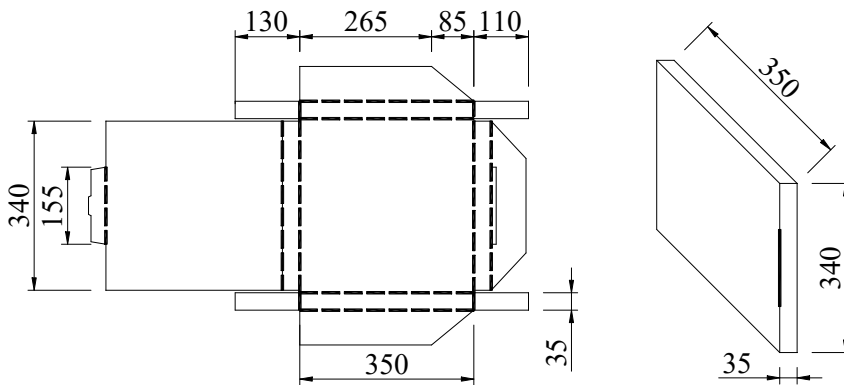

Notes:

1 units: mm

2 --- 折痕

1 REEL = 1 INNER BOX

10Box= 1Outer Box

CRYSTAL UNIT			
P/N:			
YR P/N:			
FREQ:	MHz	CL:	PF
TOL: ±	PPM (AT 25°C)
STAB: ±	PPM (°C TO	°C)
L/N:	QTY:		PCS

Lable