



PS No.	PS-008-008
Version	02
Date	2016-8-10

继电器规格书 RELAY SPECIFICATION

品名/Product Description RA1-112D
零件编号/Part Number
客户名/Customer

客户批准/Customer Approval

盖章处/STAMPING AREA

发行批准 / Issued by		
PD	SM	R&D
王凤	余明亮	冯旭强

继电器规格书 Relay Specification	型号 Type	RA1-112D	产品编号 Part Number	
1. <u>零件清单/PARTS LIST</u>				
No.	零件名 Part	材质 MATERIAL	型号/处理方式 TYPE/TREATMENT	UL FILE No. FLAME CLASS
1	骨架 Bobbin	PBT	5010GN6-30M8X	E53664
2	外壳 Case	PBT	RG301 5010GN6-30 M8	E171666 E53664
3	底板 Base	PET	FR530 RG305	E41938 E171666
4	铁芯 Core	铁 Steel	镀镍 Nickel Plated	
5	轭铁 Yoke	铁 Steel	镀镍 Nickel Plated	
6	衔铁 Armature	铁 Steel	镀镍 Nickel Plated	
7	可动弹片 S.C.C	铜合金 Cu Alloy		
8	M接点 M Contact	银合金 Ag Alloy		
9	可动接点 C Contact	银合金 Ag Alloy		
10	B接点 B Contact	银合金 Ag Alloy		
11	M端子 M Terminal	铜合金 Cu Alloy		
12	B端子 B Terminal	铜合金 Cu Alloy		
13	线圈端子 Coil Terminal	铜包钢 Cu covered Steel	镀锡 Solder Coated	
14	线材 Wire	聚氨脂漆包圆铜线 Polyurethane copper wire	3UEW 155(F Class)	E164502 E234867
15	胶水 Sealing Resin	环氧树脂 Epoxy		
16	绝缘片 Insulating sheet	LCP	S100P	E106764

PS No.:

PS-008-008

Ver

02

继电器规格书 Relay Specification	型号 Type	RA1-112D	产品编号 Part Number	
2. <u>性能/SPECIFICATIONS</u>				PS No.:
2.1 <u>驱动部分/COIL SPECIFICATIONS</u>				PS-008-008
2.1.1 额定电压 Rated Coil Voltage	12	VDC (在20°C时) VDC at 20°C		Ver
2.1.2 额定功率 Nominal Power	1	W (在20°C时) W at 20°C		02
2.1.3 线圈电阻 Coil Resistance	144	$\Omega \pm 10\%$ (在20°C时) $\Omega \pm 10\%$ (at 20°C)		
2.1.4 额定电流 Nominal Current	83.3	mA $\pm 10\%$ (在20°C时) mA $\pm 10\%$ (at 20°C)		
2.1.5 吸合电压 Operate Voltage	9	VDC以下 (在20°C时) VDC Max. at 20°C		
2.1.6 释放电压 Release Voltage	0.6	VDC以上 (在20°C时) VDC Min. at 20°C		
2.1.7 最大连续施加电压 Max Power	18.6	VDC Max. 155%额定电压 VDC Max. 155% of Nominal		
2.2 <u>开关部/CONTACT SPECIFICATION</u>				
2.2.1 开关类型 Contact Configuration		单刀转换型 1 Form C		
2.2.2 接点规格 Contact Rating	N.O.: 20 N.C.: 10	A 250VAC (阻性负载) A @250VAC (Resistive) A 250VAC (阻性负载) A @250VAC (Resistive)		
2.2.3 接触电阻 Contact Resistance	100	m Ω 以下, (初期值, DC 24V/1A条件下) m Ω Max. @ Initiate, DC 24V/1A 500 m Ω 以下, (寿命试验后, DC 24V/1A条件下) 500 m Ω Max. @ After Life, DC 24V/1A		
2.2.4 吸合时间 Operate Time	20	ms 以下 (额定电压下) ms Max. @ Rated Voltage		
2.2.5 释放时间 Release Time	10	ms 以下 (施加额定电压后断开时) ms Max. @ Rated Voltage		
2.2.6 最大动作频率 Max. Switching Rate	300	次/分 (无负载) ops./min. (no load). 6 次/分 (额定负载) ops./min. (Rated load)		

继电器规格书 Relay Specification	型号 Type	RA1-112D	产品编号 Part Number		PS No.:
2.3 特性/GENERAL SPECIFICATION					PS-008-008
2.3.1 绝缘电阻 Insulation Resistance	1000 MΩ以上 (500VDC)	1000 MΩ Min@500VDC			Ver
2.3.2 介质耐压 Dielectric Strength	1500 VAC/分钟(接点间)	2500 VAC/分钟(线圈/接点间)			02
	1500 VAC@50/60Hz 1 min.(Between Open Contacts)	2500 VAC@50/60Hz 1 min.(Between Coil and Contacts)			
2.3.3 电气寿命 Electrical Life	1X10 ⁵ 次以上 (20A AC250V额定阻性负载条件下)	1X10 ⁵ Cycle Min. @20A AC250V Rate Load			
	1X10 ⁵ 次以上 (10A AC250V额定阻性负载条件下)	1X10 ⁵ Cycle Min. @10A AC250V Rate Load			
2.3.4 机械寿命 Mechanical Life	1X10 ⁶ 次以上 (无负载)	1X10 ⁶ Cycle Min. @no load			
2.3.5 使用环境温度 Temperature	-40~85 °C (无凝结时)	-40~85 °C @no condensation			
2.3.6 使用环境湿度 Humidity	20~85% RH (无凝结时)	20~85% RH @no condensation			
2.3.7 抗振动 Vibration	耐久 10~55 Hz, 双振幅 1.5mm	Mechanical 10 to 55 Hz, 1.5mm double amplitude			
	误动作 10~55 Hz, 双振幅1.5mm	Operational 10 to 55 Hz, 1.5mm double amplitude			
2.3.8 抗冲击 Shock	耐久 980 m/s ² Min (约100G)	Mechanical 980 m/s ² Min (100G approximately)			
	误动作 98 m/s ² Min (约10G)	Operational 98 m/s ² Min (10G approximately)			
2.3.9 重量 Weight	33 克	33 g			
2.3.10 焊锡条件 Solder ability	5s @ 260°C (波峰焊)	5s @ 260°C (wave soldering)			
2.4 端子性能/TERMINAL CHARACTERISTICS					
2.4.1 端子强度 Terminals strength	5牛/10秒, 任意方向静态压力, 无异常, 但端子弯曲可以 5N 10s, There shall be no abnormalities. (The curving of the terminal shall be acceptable)				
2.4.2 可焊性 Terminal solderbility	260±5°C 3s, 端子头部3mm部分90%以上的面积有锡覆盖 (无铅焊锡) 260±5°C 3s, In Case of lead lead free solder, 90% of the dipped portion shall be solderd.				
2.4.3 耐热性 Soldering Heat Resistance	10s 260°C或3s 350°C, 端子头部3mm浸入锡中, 无异常发生 10s @ 260°C or 3s @ 350°C, There shall be no abnormalities. (wave soldering)				

2.5 安全规格/SAFETY REQUIREMENTS

2.5.1 UL规格认定 (UL & C-UL)
UL (UL & C-UL)

档案号: E345228
File No.:



2.5.2 CQC标志认证
CQC

证书编号: CQC12002078691
Certificate No.: CQC16002139641



2.5.3 TUV规格认定
TUV

证书号 R 50228669
Certificate No.



2.5.4 产品符合ROHS和REACH要求。
The product meets the requirements of ROHS & REACH.

3. 捺印图/Mark Layout

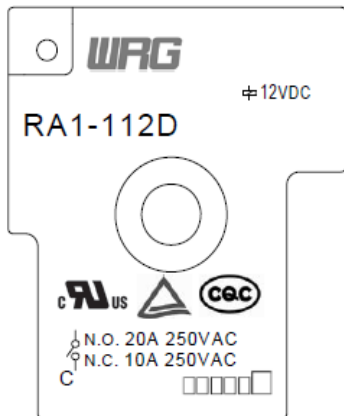

Batch No. Identification:

H □ □ □ □

- 1、Manufactory:
Blank: Shenzhen; H: Huangshan
- 2、Year
The last two digits of the year.
- 3、Week
Production of the current week.
- 4、Lot No.
(A,B,C,.....Z) OR (AA,BB,CC,.....ZZ)

注:
仅供参考.
For reference only.

注/Remark

以中文版为准, 英文版仅供参考。
Chinese version is the standard one, English version is only for information.

结束/<END>

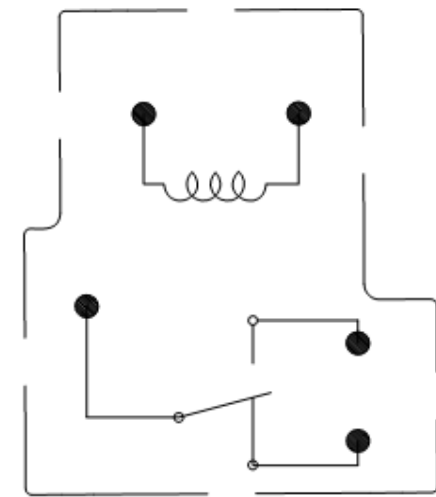
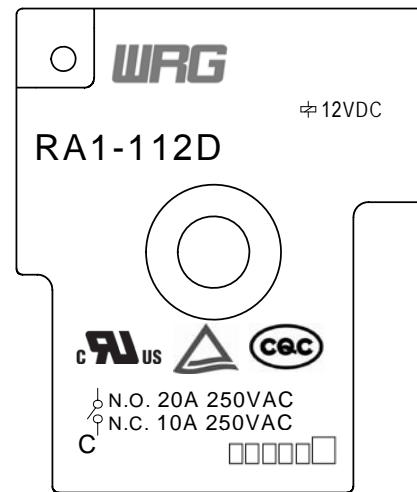
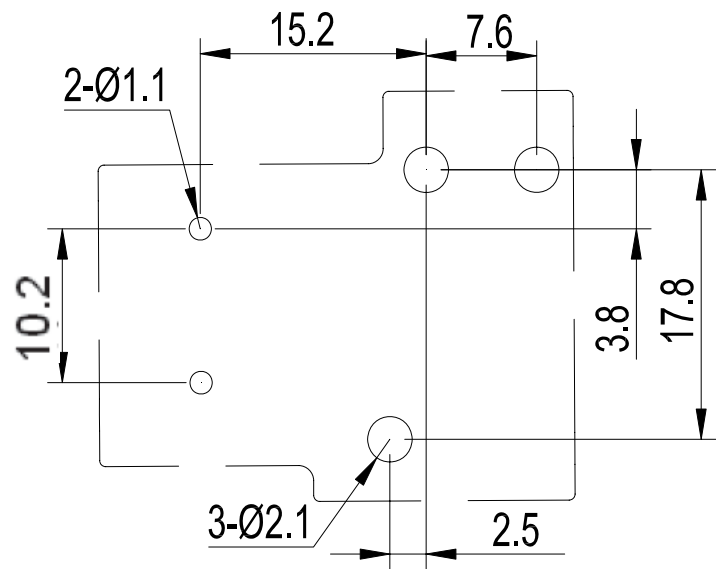
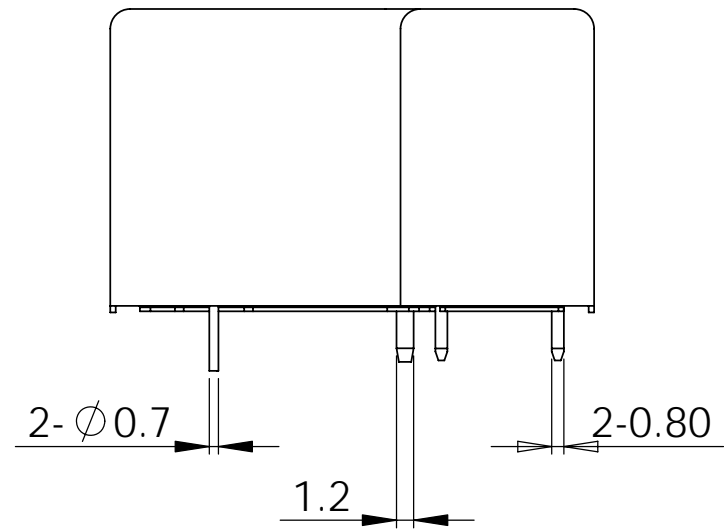
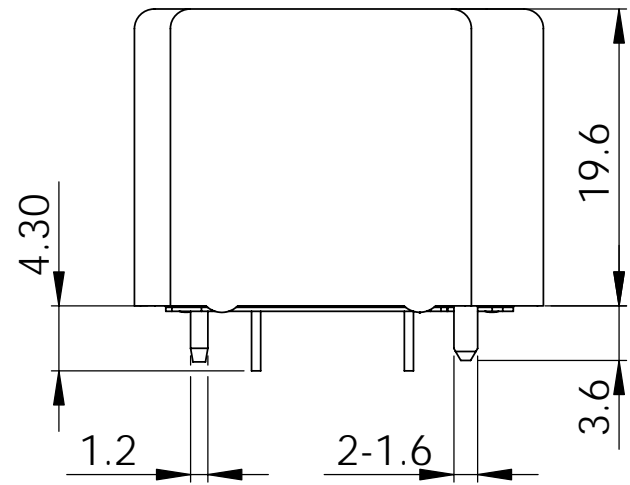
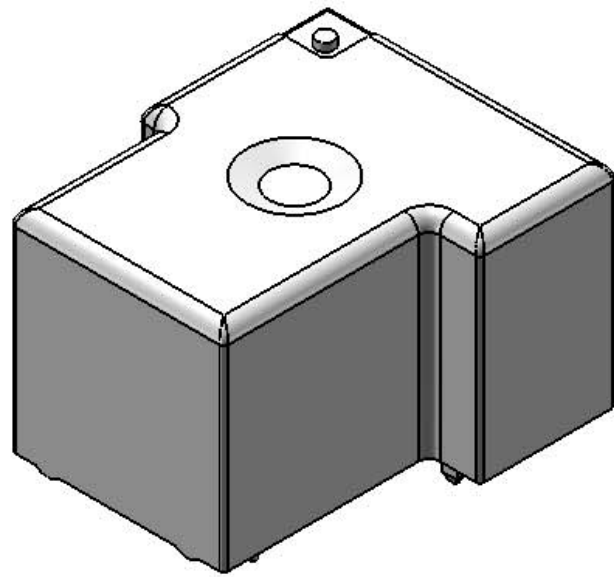
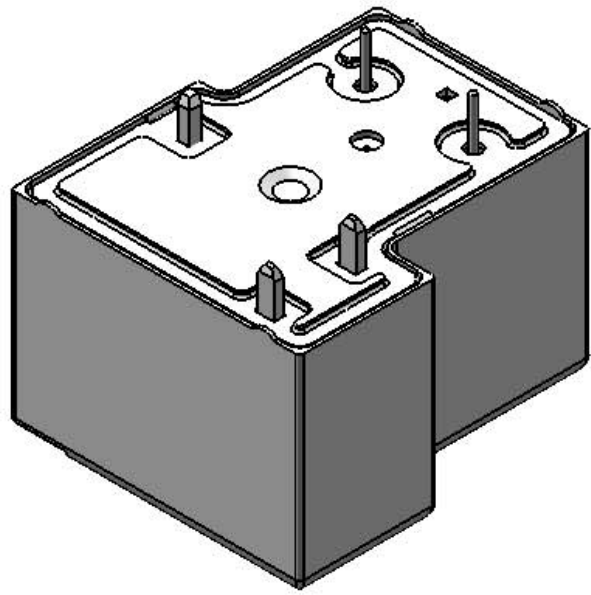

型号	RA1	子图号	承认	检图	制图
公差/TOLERANCES (. mm)		作图日期	船山		周波
		2012. 04. 25			
<1	± 0.2	数量	版本	名称 (用途)	
1 ~ 5	± 0.3	1	V1.0	RA1 C型	
>5	± 0.4	比例	页数	图号	
		2:1	1/1	U-008-01D	