

CUSTOMER DRAWING

02506HY 43M-W ASSY

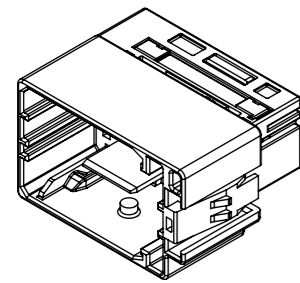

ISO VIEW

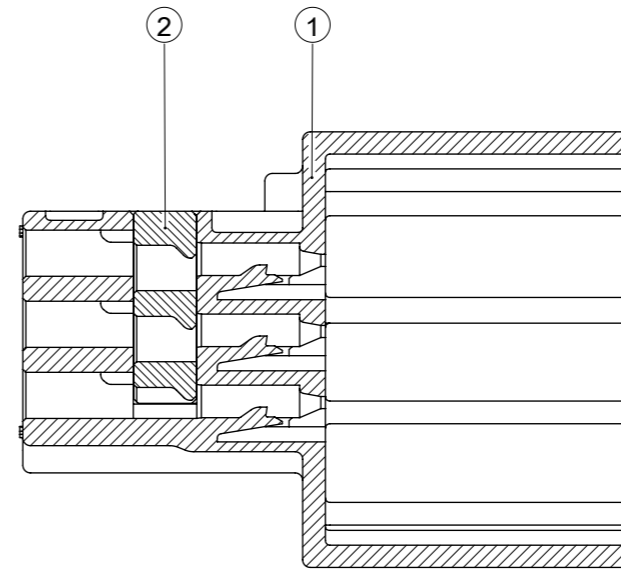
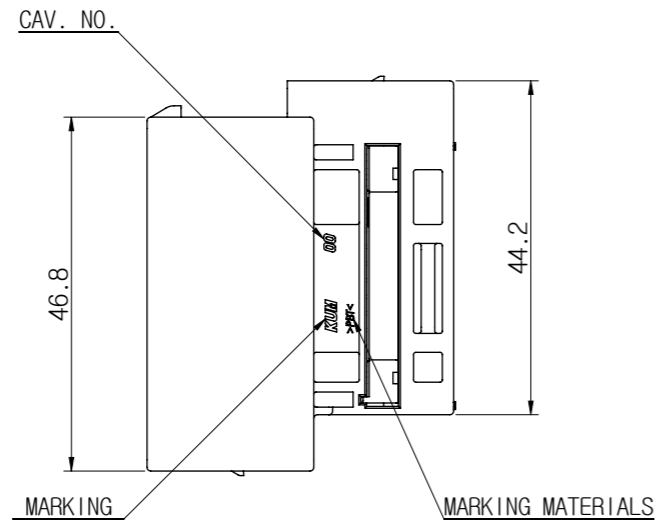

SECTION B-B(2/1)

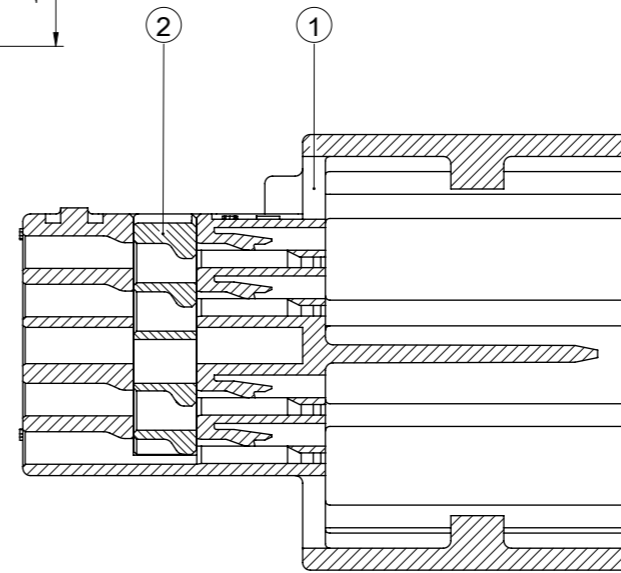
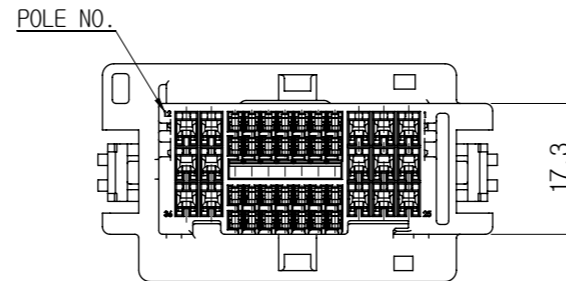
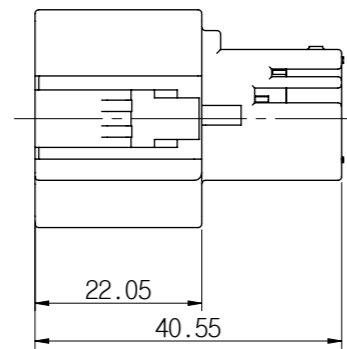
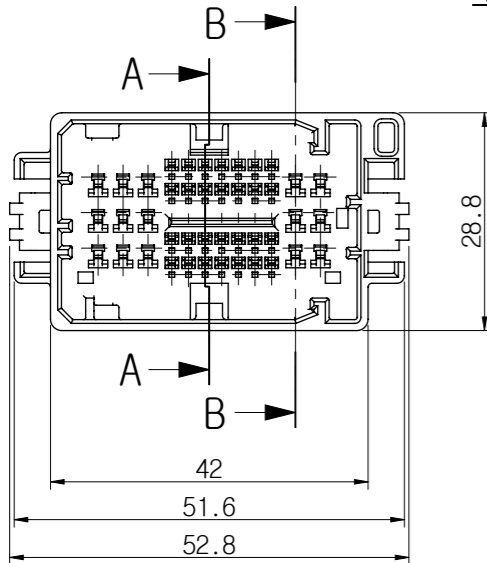

SECTION A-A(2/1)

S/H 02506HY 43M-GN

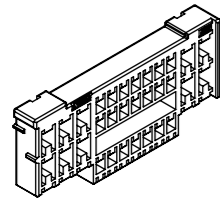

ISO VIEW

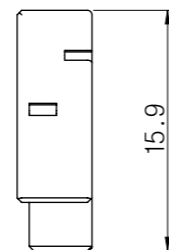
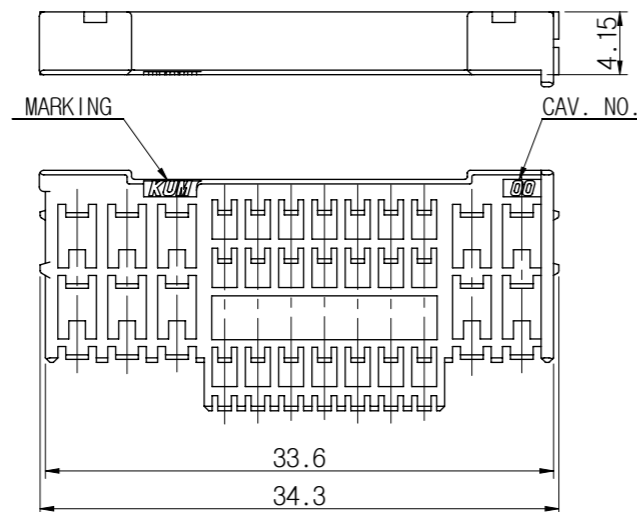

- NOTE -

- BEFORE USING, CHECK THE HARMFUL CRACK, BURR, ETC.
- GENERAL TOLERANCES - SEE BLOW.
- MARKING & CAV No. BY AS GENERAL RULE OF KUM.
- ASSY PART

1) TERMINAL

APPLICATION WIRE(SQ)	PART NAME	PART NO.
AVSS 0.3-0.5sq	TML MMC-M-S	TK191-00100
	TML MMC-M-S-Au	TK191-00110
CHFUS 0.22sq	TML MMC-M-SS	TK191-00400
	TML MMC-M-SS-Au	TK191-00410
AVSS 0.85~1.25sq	TML NIC-M-M	TK201-00200
AVSS 0.3-0.5sq	TML NIC-M-S	TK201-00100

- THIS PART IS NON-WATERPROOF CONNECTOR.

GENERAL TOLERANCE

	10MAX	50MAX	100MAX	150MAX	200MAX	200VR	ANGLE
A	±0.2	±0.3	±0.5	±0.8	±1.0	±1.4	±30'

NO.	PART NAME	PART No.	COLOR	MATERIAL
②	S/H 02506HY 43M-GN	HK251-43030	GREEN	PBT
①	02506HY 43M-W	HK241-43010	WHITE	PBT
THIRD ANGLE PROJECTION	A	-	BSH	BSH
TOLERANCE		SCALE	DESIGN	DRAWN
			CHECKED	APPROVED

CJW	11.09.27	E011-0130	△	RELEASED	BSH
APVD	DATE	NOTE No.	SYM	ALTERATION	DWN

DRAWING NAME 02506HY 43M-W ASSY

DRAWING No. HK241-43011-C01

KUM 케이유엠