



## **S3 Family 8-Bit Microcontrollers**

# **S3F8S19/S3F8S15**

## **Product Specification**

PS031201-0813

PRELIMINARY





**Warning:** DO NOT USE THIS PRODUCT IN LIFE SUPPORT SYSTEMS.

---

## LIFE SUPPORT POLICY

ZILOG'S PRODUCTS ARE NOT AUTHORIZED FOR USE AS CRITICAL COMPONENTS IN LIFE SUPPORT DEVICES OR SYSTEMS WITHOUT THE EXPRESS PRIOR WRITTEN APPROVAL OF THE PRESIDENT AND GENERAL COUNSEL OF ZILOG CORPORATION.

### As used herein

Life support devices or systems are devices which (a) are intended for surgical implant into the body, or (b) support or sustain life and whose failure to perform when properly used in accordance with instructions for use provided in the labeling can be reasonably expected to result in a significant injury to the user. A critical component is any component in a life support device or system whose failure to perform can be reasonably expected to cause the failure of the life support device or system or to affect its safety or effectiveness.

### Document Disclaimer

©2013 Zilog, Inc. All rights reserved. Information in this publication concerning the devices, applications, or technology described is intended to suggest possible uses and may be superseded. ZILOG, INC. DOES NOT ASSUME LIABILITY FOR OR PROVIDE A REPRESENTATION OF ACCURACY OF THE INFORMATION, DEVICES, OR TECHNOLOGY DESCRIBED IN THIS DOCUMENT. ZILOG ALSO DOES NOT ASSUME LIABILITY FOR INTELLECTUAL PROPERTY INFRINGEMENT RELATED IN ANY MANNER TO USE OF INFORMATION, DEVICES, OR TECHNOLOGY DESCRIBED HEREIN OR OTHERWISE. The information contained within this document has been verified according to the general principles of electrical and mechanical engineering.

S3 and Z8 are trademarks or registered trademarks of Zilog, Inc. All other product or service names are the property of their respective owners.



# Revision History

Each instance in this document's revision history reflects a change from its previous edition. For more details, refer to the corresponding page(s) or appropriate links furnished in the table below.

| <b>Date</b> | <b>Revision Level</b> | <b>Description</b>   | <b>Page</b> |
|-------------|-----------------------|--|-------------|
| Aug 2013    | 01                    | Original Zilog issue. A table of contents and PDF bookmarks will appear in the next edition, due to be published on or before Winter 2013. | All         |

# 1 Product Overview

## 1.1 S3C8-Series Microcontrollers

SAM8RC family of Samsung of 8-bit single-chip Complementary Metal Oxide Semiconductor (CMOS) microcontrollers offers a fast and efficient CPU, a wide range of integrated peripherals, and various mask-programmable ROM sizes. Address/data bus architecture and a large number of bit-configurable Input/Output (I/O) ports provide a flexible programming environment for applications with varied memory and I/O requirements. It includes timer/counters with selectable operating modes to support real-time operations.

## 1.2 S3F8S19/F8S15 Microcontroller

It fabricates the S3F8S19/F8S15 single-chip CMOS microcontrollers by using the highly advanced CMOS process technology based on the latest CPU architecture of Samsung.

The S3F8S19/F8S15 is a microcontroller with an embedded 32/16 Kbyte full-flash ROM.

By using a proven modular design approach, Samsung engineers have successfully developed the S3F8S19/F8S15 by integrating these peripheral modules with the powerful SAM8 RC core:

- Five configurable I/O ports (40 pin)
- Twenty-six interrupt sources and Eight interrupt levels
- Eight bit-programmable pins for external interrupts
- One stop wake up timer function
- One 8-bit basic timer for oscillation stabilization
- One 8-bit timer/counter and Four 16-bit timer/counters with selectable operating modes
- Watch timer for real time
- LCD Controller/driver
- Two asynchronous UART modules
- One Serial Peripheral Interface (SPI) module
- One Inter Integrated Circuit (IIC) module
- Analog to digital converter with 10 input channels and 10-bit resolution
- One Buzzer (BUZ) for programmable frequency output

The S3F8S19/F8S15 microcontroller is ideal for use in a wide range of home applications that requires simple timer/counter, Analog-to-Digital Converter (ADC), LCD, and so on. They are currently available in 48-pin QFP package.

| Comparison         | S3F8S19 | S3F8S15 |
|--------------------|---------|---------|
| Flash Size (Bytes) | 32K     | 16K     |

## 1.3 Features

### 1.3.1 CPU

- SAM88RC CPU core

### 1.3.2 Memory

Features of internal multi-time program Full-Flash memory are:

- 32K × 8 bits program memory (S3F8S19)
- 16K × 8 bits program memory (S3F8S15)
  - Sector size: 128 bytes
  - User programmable by "LDC" instruction
  - Sector erase available
  - Fast programming time
  - External serial programming support
  - Endurance: 10,000 erase/program cycles
  - 10 Years data retention
- Data Memory (RAM)
  - Including LCD display data memory
  - 2,086 × 8 bits data memory

### 1.3.3 Instruction Set

- Seventy eight instructions
- Idle and Stop instructions

### 1.3.4 40 I/O Pins

- Forty normal I/O pins for 48 pin

### 1.3.5 Interrupts

- Eight interrupt levels and 26 interrupt sources
- Fast interrupt processing feature

### 1.3.6 Timers and Timer/Counters

- One programmable 8-bit basic timer (BT) for oscillation stabilization control or watchdog timer function.
- One 8-bit timer/counter (Timer A) with three operating modes:
  - Interval mode
  - capture mode
  - Pulse Width Modulation (PWM) mode
- One 16-bit timer/counter (Timer 0) with Interval mode and PWM mode.
- Two 16-bit timer/counter (Timer 1/2) with three operating modes:
  - Interval mode
  - Capture mode
  - PWM mode
- One 16-bit timer/counter (Timer B) with one-shot pulse mode and repeating output mode. It can be triggered by external input or software.
- One STOP Wake-up Timer with Ring oscillator as its clock source.

### 1.3.7 Watch Timer

- Interval time: 1.995 ms, 0.125s, 0.25s, and 0.5s at 32.768 kHz
- 0.5/1/2/4 kHz buzzer output selectable

### 1.3.8 Analog to Digital Converter

- 10-channel analog input
- 10-bit conversion resolution

### 1.3.9 Two Channels Universal Asynchronous Receiver/Transmitter (UART)

- Full-duplex serial I/O interface
- Four programmable operating modes
- Auto generating parity bit

### 1.3.10 Multi-Master IIC-Bus

- Serial Peripheral Interface
- Serial, 8-bit Data Transfers
- Programmable Clock Pre-scale

### 1.3.11 SPI

- Support Master and Slave Mode
- Programmable Clock Pre-scale

### 1.3.12 LCD Controller/Driver

- Sixteen segments and 8 common terminals
- 1/2, 1/3, 1/4, and 1/8 duty selectable
- Resistor or capacitor bias selectable
- Regulator and booster circuit for LCD bias

### 1.3.13 Two Power-Down Modes

- **Idle mode:** Only CPU clock stops
- **Stop mode:** System clock and CPU clock stop

### 1.3.14 Oscillation Sources

- Main clock frequency: 0.4 MHz to 12.0 MHz
- External RC for main clock
- 32 kHz external crystal or ceramic sub oscillator
- Internal RC: 8 MHz (typ.), 4 MHz (typ.), 1 MHz (typ.), 0.5 MHz (typ.)
- On-chip free running Ring oscillator with 32 kHz frequency for 16-bit Timer 1.

### 1.3.15 Instruction Execution Time

- 333 ns at  $f_x = 12$  MHz (minimum, main clock)
- 122  $\mu$ s at  $f_{xt} = 32.768$  kHz (sub clock)

### 1.3.16 Built-In RESET Circuit (LVR)

- Low-Voltage check to reset system
- $V_{LVR} = 1.9/2.3/3.0/3.9$  V (by smart option)

### **1.3.17 Low Voltage Detect Circuit (LVD)**

- Flag or Interrupt for Voltage drop detection
- Programmable detect voltage: 2.1/2.5/3.2/4.1 V
- Enable/Disable selected by software

### **1.3.18 Operating Voltage Range**

- 1.8 V to 5.5 V at 4 MHz (main clock)
- 2.7 to 5.5 V at 12 MHz (main clock)
- 1.8 V to 5.5 V at 32.768 kHz (sub clock)

### **1.3.19 Package Type**

- 48-pin QFP

### **1.3.20 Operating Temperature Range**

- – 40 °C to + 85 °C

### **1.3.21 Smart Option**

- ISP-related option selectable (ROM address 3EH)
- Oscillator selection, LVR selection (ROM address 3FH)



1.4 Block Diagram

Figure 1-1 illustrates the block diagram of S3F8S19/F8S15.

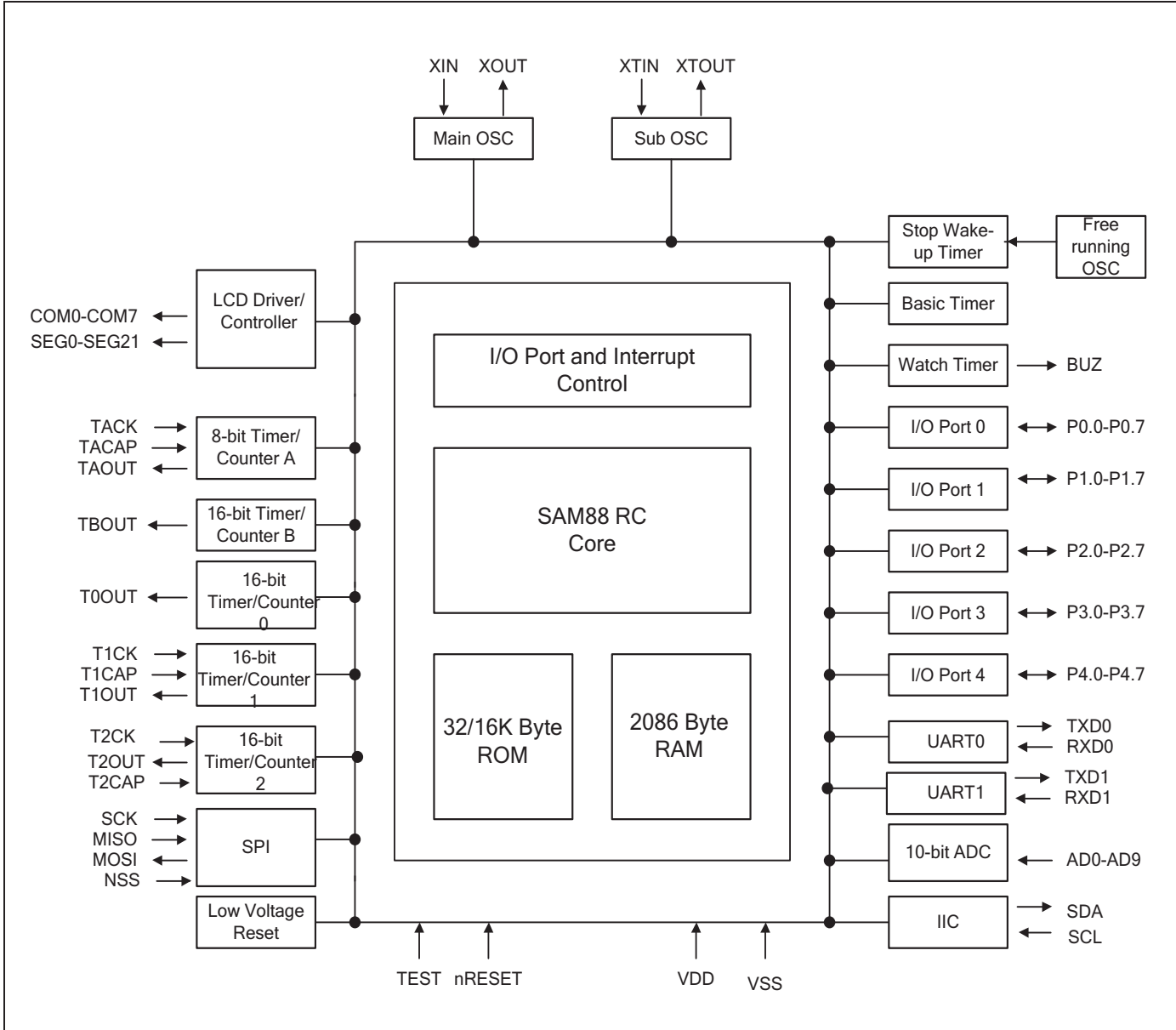
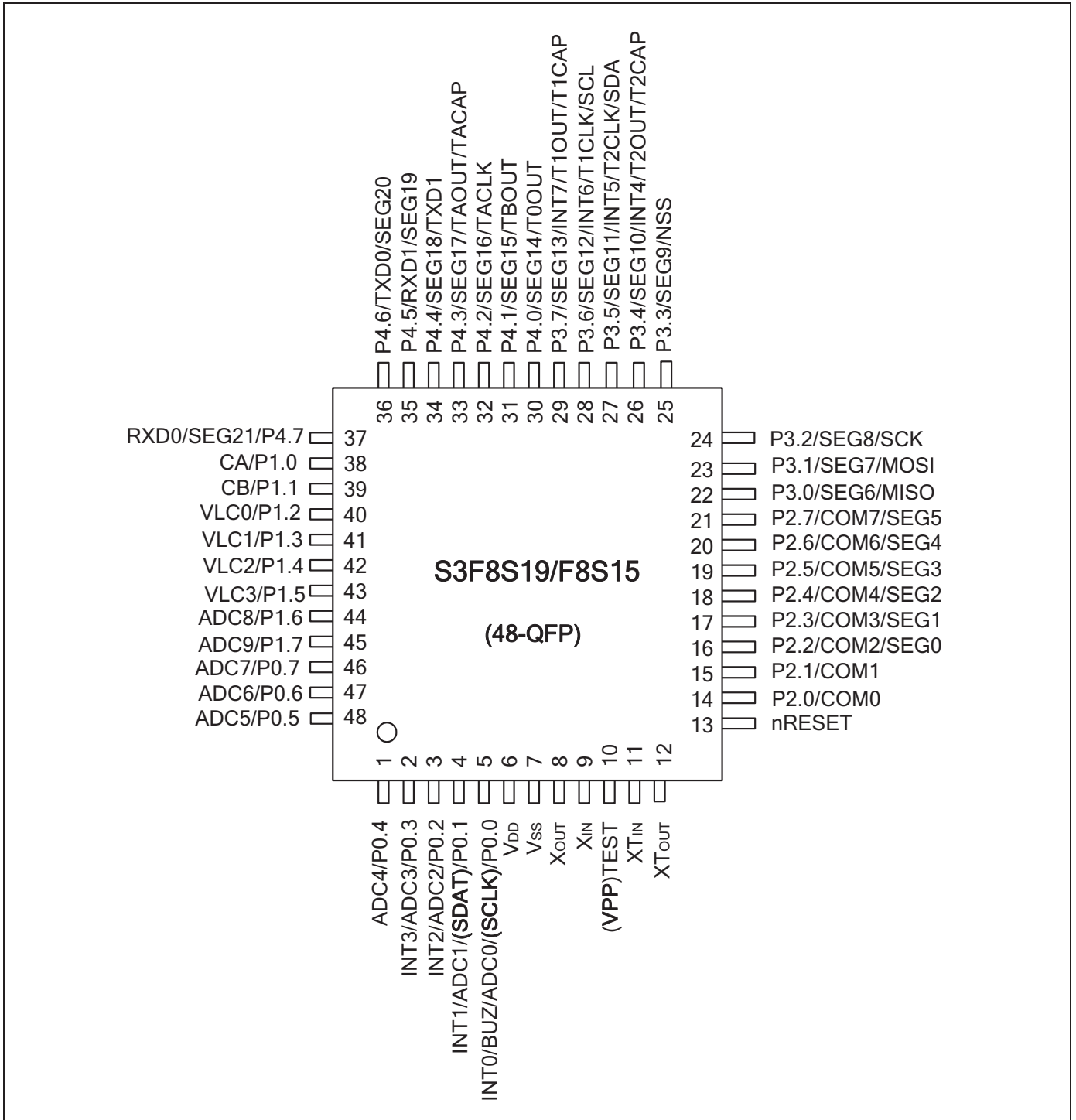


Figure 1-1 S3F8S19/F8S15 Block Diagram

## 1.5 Pin Assignments

Figure 1-2 illustrates the S3F8S19/F8S15 Pin Assignments.



**Figure 1-2 S3F8S19/F8S15 Pin Assignments (48-QFP)**

## 1.6 Pin Descriptions

[Table 1-1](#) describes the Pin Descriptions of 48-QFP.

**Table 1-1 Pin Descriptions of 48-QFP**

| Pin Name     | Pin Type | Pin Description  | Circuit Type | Pin No. | Shared Functions            |
|--------------|----------|--|--------------|---------|-----------------------------|
| P0.0         | I/O      | I/O port with bit-programmable pins<br>Input or push-pull output and software assignable pull-ups.                             | F-16         | 5       | ADC0/INT0/BUZ/              |
| P0.1 – P0.3  |          |  |              | 4 – 2   | ADC1 – ADC3<br>/INT0 – INT3 |
| P0.4<br>P0.5 |          |  |              | 1<br>48 | ADC4<br>ADC5                |
| P0.6 – P0.7  |          |  |              | 47 – 46 | ADC6 – ADC7                 |
| P1.0         | I/O      | I/O port with bit-programmable pins<br>Input or push-pull output and software assignable pull-ups.                             | F-17         | 38      | CA                          |
| P1.1         |          |  |              | 39      | CB                          |
| P1.2 – P1.5  |          |  |              | 40 – 43 | VLC0 – VLC3                 |
| P1.6 – P1.7  | I/O      | Bit programmable output pins<br>Input or push-pull output and software assignable pull-ups.                                    | F-16         | 44 – 45 | ADC8 – ADC9                 |
| P2.0 – P2.1  | I/O      | I/O port with bit-programmable pins<br>Input or push-pull output and software assignable pull-ups.                             | H-44         | 14 – 15 | COM0 – COM1                 |
| P2.2 – P2.7  |          |  |              | 16 – 21 | COM2 – COM7/<br>SEG0 – SEG5 |
| P3.0         | I/O      | I/O port with bit-programmable pins<br>Schmitt trigger input or push-pull, open-drain output and software assignable pull-ups. | H-41         | 22      | SEG6/MISO                   |
| P3.1         |          |  |              | 23      | MOSI/SEG7                   |
| P3.2         |          |  |              | 24      | SCK/SEG8                    |
| P3.3         |          |  |              | 25      | NSS/SEG9                    |
| P3.4         |          |  |              | 26      | INT4/T2OUT/T2CAP/SEG10      |
| P3.5         |          |  |              | 27      | INT5/SDA/SEG11              |
| P3.6         |          |  |              | 28      | INT6/T1CLK/SEG12/SCL        |
| P3.7         |          |  |              | 29      | INT7/T1OUT/T1CAP/SEG13      |
| P4.0         | I/O      | I/O port with bit-programmable pins<br>Input or push-pull, open-drain output and software assignable pull-ups                  | H-42         | 30      | T0OUT/SEG14                 |
| P4.1         |          |  |              | 31      | TBOUT/SEG15                 |
| P4.2         |          |  |              | 32      | TACLK/SEG16                 |
| P4.3         |          |  |              | 33      | TAOUT/TACAP/SEG17           |
| P4.4         |          |  |              | 34      | TXD1/SEG18                  |
| P4.5         |          |  |              | 35      | TXD1/SEG19                  |
| P4.6         |          |  |              | 36      | TXD0/SEG20                  |
| P4.7         |          |  |              | 37      | RXD0/SEG21                  |
| COM0 – COM1  | I/O      | LCD common signal output.  | H-44         | 14 – 15 | P2.0 – P2.1                 |
| COM2 – COM7  |          |  |              | 16 – 21 | P2.2 – P2.7/SEG0 – SEG5     |

| Pin Name    | Pin Type | Pin Description                         | Circuit Type | Pin No.                 | Shared Functions      |
|-------------|----------|---|--------------|-------------------------|-----------------------|
| SEG6        | I/O      | LCD segment signal output.              | H-41         | 22                      | P3.0/MISO             |
| SEG7        |          |   |              | 23                      | P3.1/MOSI             |
| SEG8        |          |   |              | 24                      | P3.2/SCK              |
| SEG9        |          |   |              | 25                      | P3.3/NSS              |
| SEG10       |          |   |              | 26                      | P3.4/INT4/T2OUT/T2CAP |
| SEG11       |          |   |              | 27                      | P3.5/INT5/T2CLK/SDA   |
| SEG12       |          |   |              | 28                      | P3.6/INT6/T1CLK/SCL   |
| SEG13       |          |   |              | 29                      | P3.7/INT7/T1OUT/T1CAP |
| SEG14       | I/O      | LCD segment signal output.              | H-42         | 30                      | P4.0/T0OUT            |
| SEG15       |          |   |              | 31                      | P4.1/TBOUT            |
| SEG16       |          |   |              | 32                      | P4.2/TACLK            |
| SEG17       |          |   |              | 33                      | P4.3/TAOUT/TACAP      |
| SEG18       |          |   |              | 34                      | P4.4/TXD1             |
| SEG19       |          |   |              | 35                      | P4.5/RXD1             |
| SEG20       |          |   |              | 36                      | P4.6/TXD0             |
| SEG21       |          |   |              | 37                      | P4.7/RXD0             |
| CA          | –        | Capacitor terminal for voltage booster. | F-17         | 38                      | P1.0                  |
| CB          | –        | Capacitor terminal for voltage booster. | F-17         | 39                      | P1.1                  |
| VLC0 – VLC3 | –        | LCD power supply pins.                  | F-17         | 40 – 43                 | P1.2 – P1.5           |
| ADC0        | I/O      | A/D converter analog input channels.    | F-16         | 5                       | P0.0/INT0/BUZ/(SCLK)  |
| ADC1        |          |   |              | 4                       | P0.1/INT1(SDAT)       |
| ADC2        |          |   |              | 3                       | P0.2/INT2             |
| ADC3        |          |   |              | 2                       | P0.3/INT3             |
| ADC4        |          |   |              | 1                       | P0.4                  |
| ADC5 – ADC7 |          |   | 48 – 46      | P0.5 – P0.7             |                       |
| ADC8 – ADC9 |          |   | F-16         | 44 – 45                 | P1.6 – P1.7           |
| TXD0        |          |   | I/O          | UART data output, input | H-42                  |
| RXD0        | 37       | P4.7/SEG21                              |              |                         |                       |
| TXD1        | 34       | P4.4/SEG18                              |              |                         |                       |
| RXD1        | 35       | P4.5/SEG19                              |              |                         |                       |
| SDA         | I/O      | IIC data output, input                  | H-41         | 27                      | P3.5/SEG11/INT5/T2CLK |
| SCL         |          |   |              | 28                      | P3.6/SEG12/INT6/T1CLK |
| TAOUT       | I/O      | Timer A clock output and PWM output.    | H-42         | 33                      | P4.3/SEG17/TACAP      |
| TACAP       | I/O      | Timer A capture input.                  | H-42         | 33                      | P4.3/SEG17/TAOUT      |
| TACLK       | I/O      | Timer A external clock input.           | H-42         | 32                      | P4.2/SEG16            |
| TBOUT       | I/O      | Timer B carrier frequency output        | H-42         | 31                      | P4.1/SEG15            |

| Pin Name      | Pin Type | Pin Description                                      | Circuit Type | Pin No.  | Shared Functions          |
|---------------|----------|--|--------------|----------|---------------------------|
| T1CAP         | I/O      | Timer 1 capture input.                               | H-41         | 29       | P3.7/SEG13/INT7/T1OUT/    |
| T1CLK         | I/O      | Timer 1 external clock input.                        | H-41         | 28       | P3.6/SEG12/INT6/SCL       |
| T2OUT         | I/O      | Timer 2 clock output and PWM output.                 | H-41         | 26       | P3.4/SEG10/INT4/T2CAP     |
| T2CAP         | I/O      | Timer 2 capture input.                               | H-41         | 26       | P3.4/SEG10/INT4/T2OUT     |
| T2CLK         | I/O      | Timer 2 external clock input.                        | H-41         | 27       | P3.5/SEG11/INT5/SDA       |
| BUZ           | I/O      | Output pin for buzzer signal.                        | H-41         | 5        | P0.0/ADC0/INT0/(SCLK)     |
| SCK           | I/O      | SPI interface clock                                  | H-41         | 24       | P3.2/SEG8                 |
| MISO          | I/O      | SPI Master input slave output                        | H-41         | 22       | P3.0/SEG6                 |
| MOSI          | I/O      | SPI Master output slave input                        | H-41         | 23       | P3.1/SEG7                 |
| NSS           | I        | Slave selection                                      | -            | 25       | P3.3/SEG9                 |
| INT0 – INT3   | I        | External interrupt input pins                        | F-16         | 5 – 2    | P0.0 – P0.3/ADC0 – ADC3   |
| INT4 – INT7   | I        | External interrupt input pins                        | H-41         | 26 – 29  | P3.4 – P3.7/SEG10 – SEG13 |
| nRESET        | I        | System reset pin                                     | B            | 13       | –                         |
| XIN<br>XOUT   | –        | Main oscillator pins.                                | –            | 9<br>9   | –                         |
| XTIN<br>XTOUT | –        | Crystal oscillator pins for sub clock.               | –            | 11<br>12 | –                         |
| TEST          | I        | Test input: It should be connected 100nF cap to GND. | –            | 10       | –                         |
| VDD           | –        | Power supply input pin                               | –            | 6        | –                         |
| VSS           | –        | Ground pins  | –            | 7        | –                         |

### 1.7 Pin Circuits

Figure 1-3 illustrates the pin circuit type A.

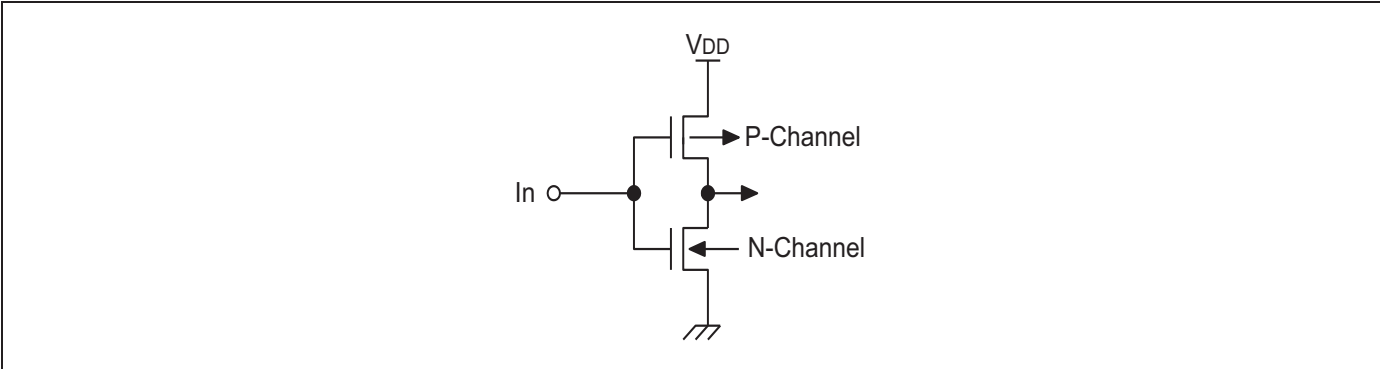


Figure 1-3 Pin Circuit Type A

Figure 1-4 illustrates the pin circuit type B.

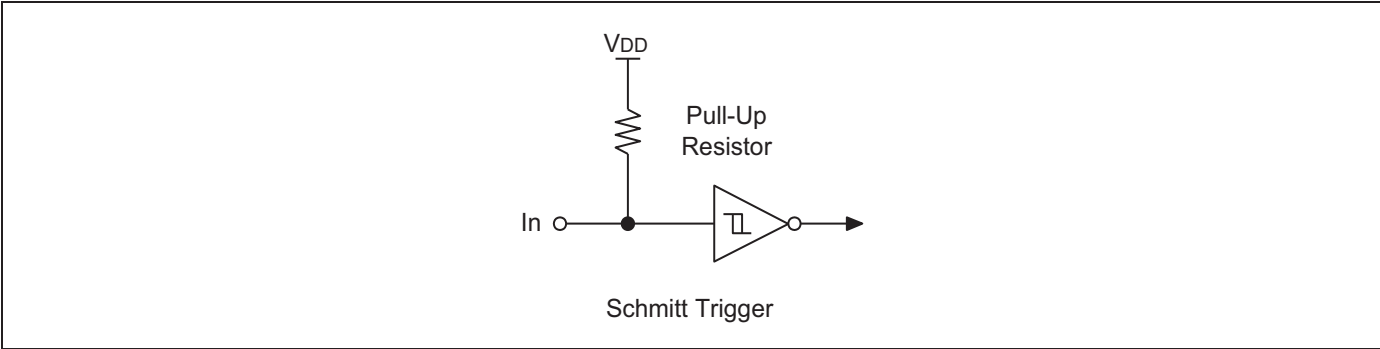


Figure 1-4 Pin Circuit Type B

Figure 1-5 illustrates the pin circuit type C.

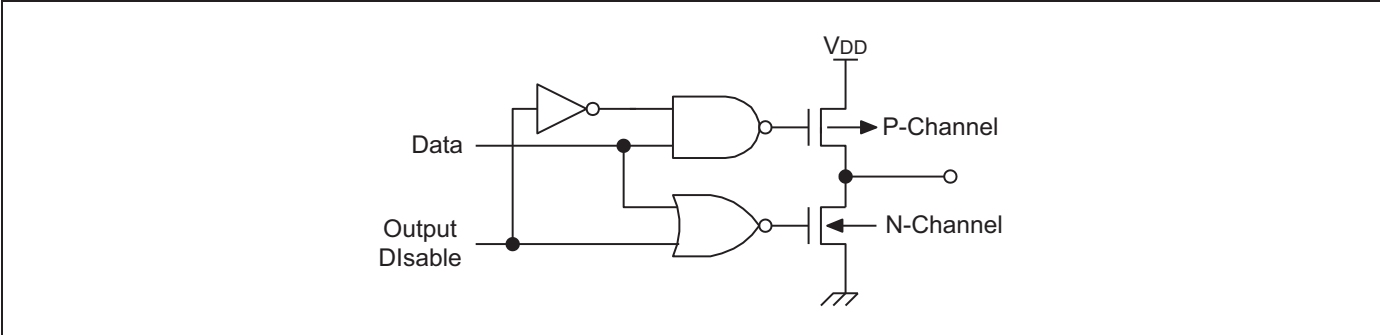


Figure 1-5 Pin Circuit Type C

Figure 1-6 illustrates the pin circuit type F-16 (P0).

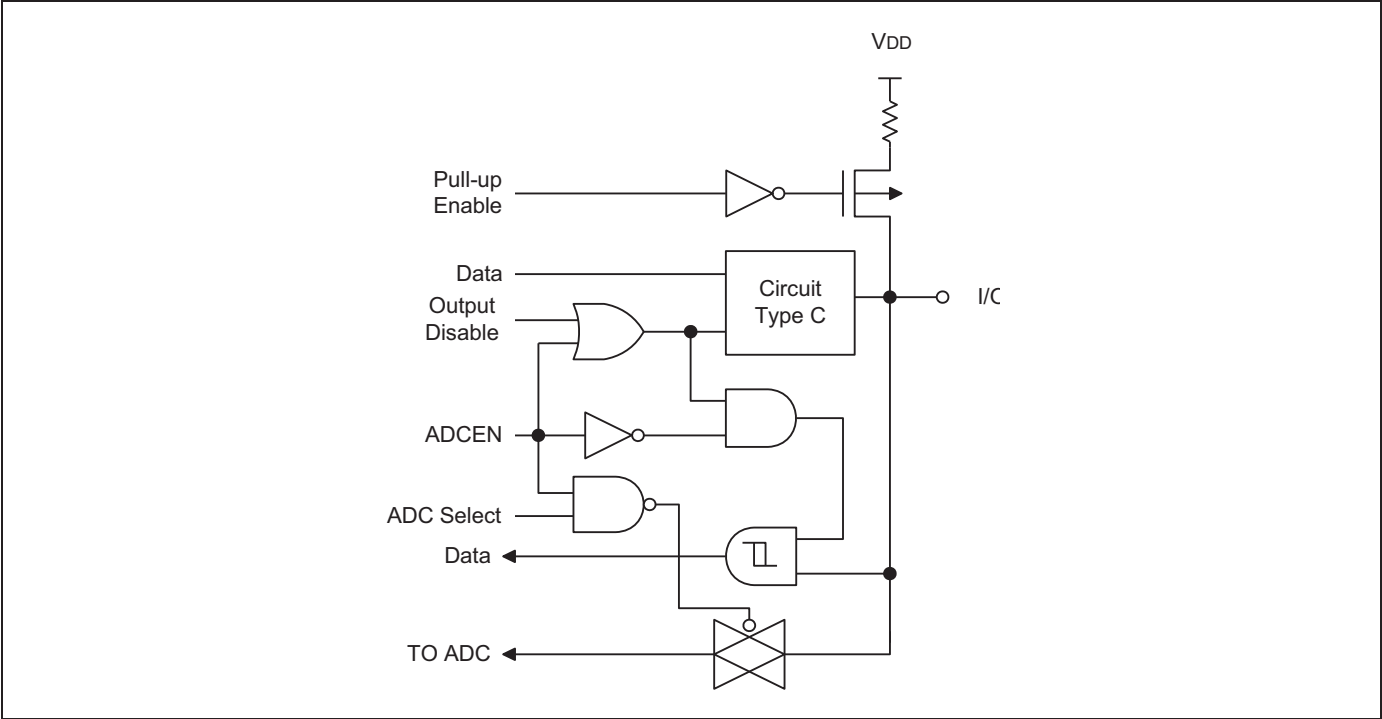


Figure 1-6 Pin Circuit Type F-16 (P0)

Figure 1-7 illustrates the pin circuit type H-39.

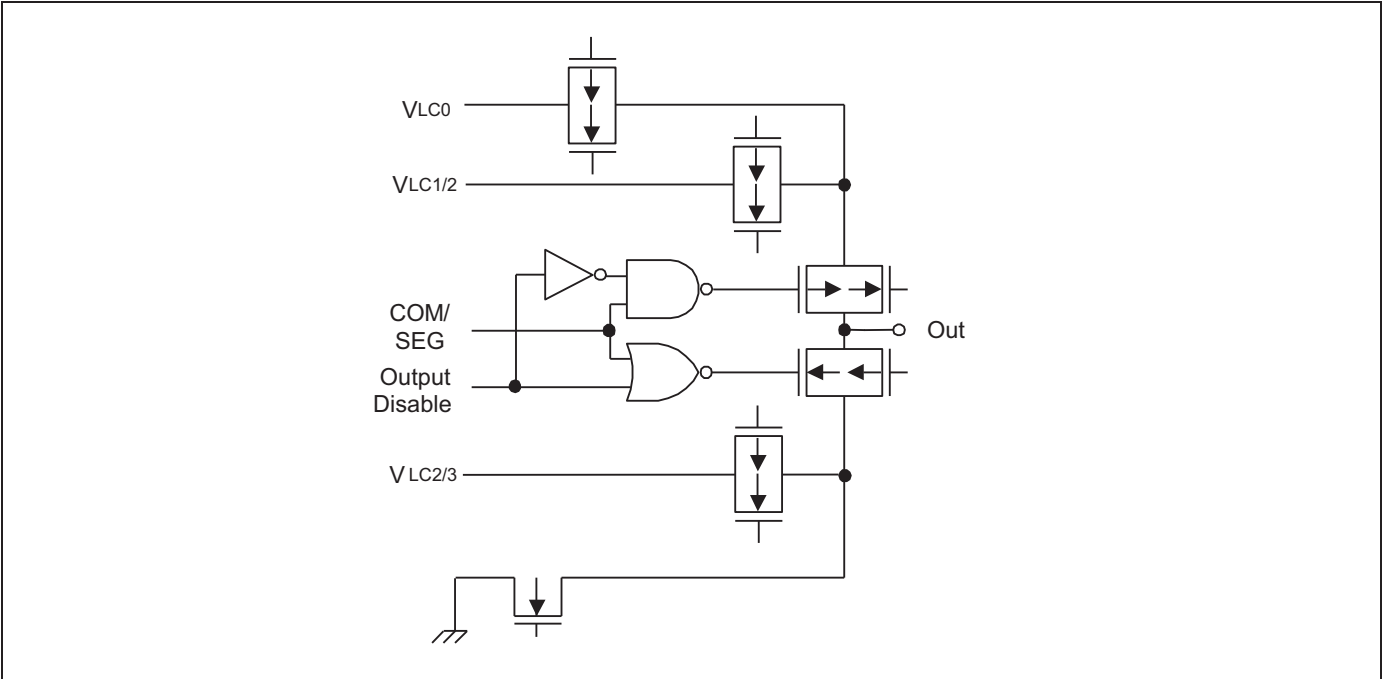


Figure 1-7 Pin Circuit Type H-39

Figure 1-8 illustrates the pin circuit type H-44 (P2).

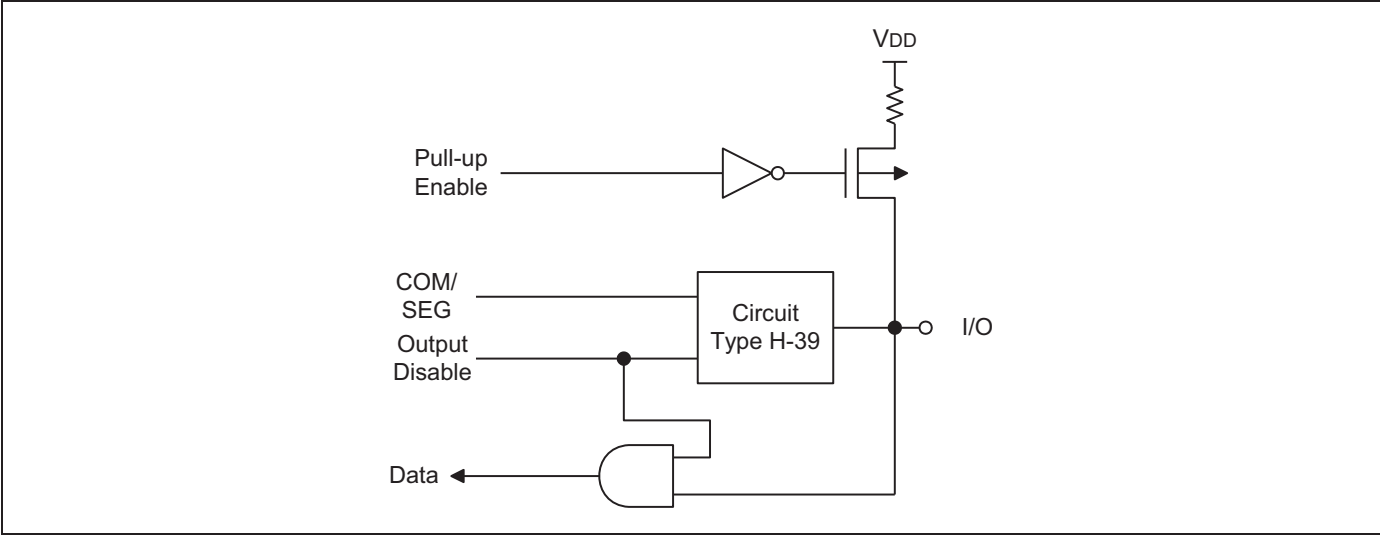


Figure 1-8 Pin Circuit Type H-44 (P2)

Figure 1-9 illustrates the pin circuit type F-17 (P1).

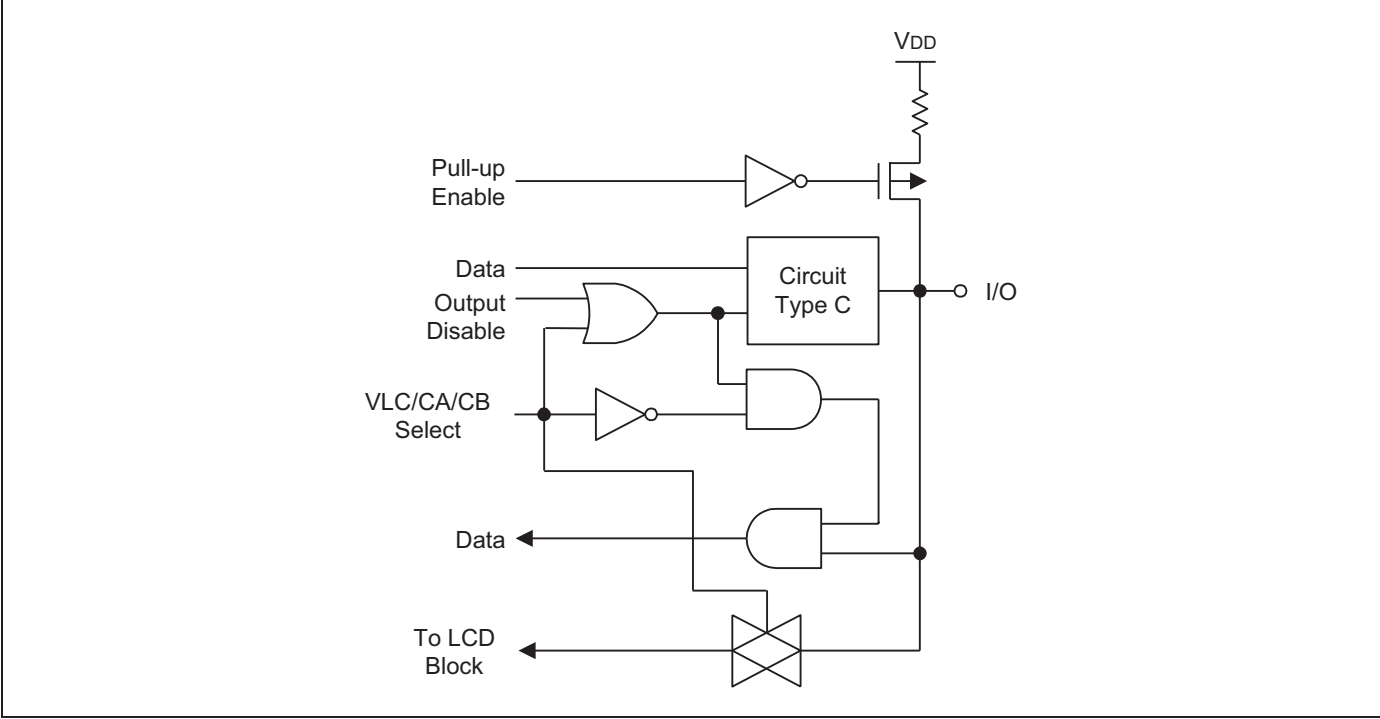


Figure 1-9 Pin Circuit Type F-17(P1)



Figure 1-10 illustrates the pin circuit type H-41 (P3).

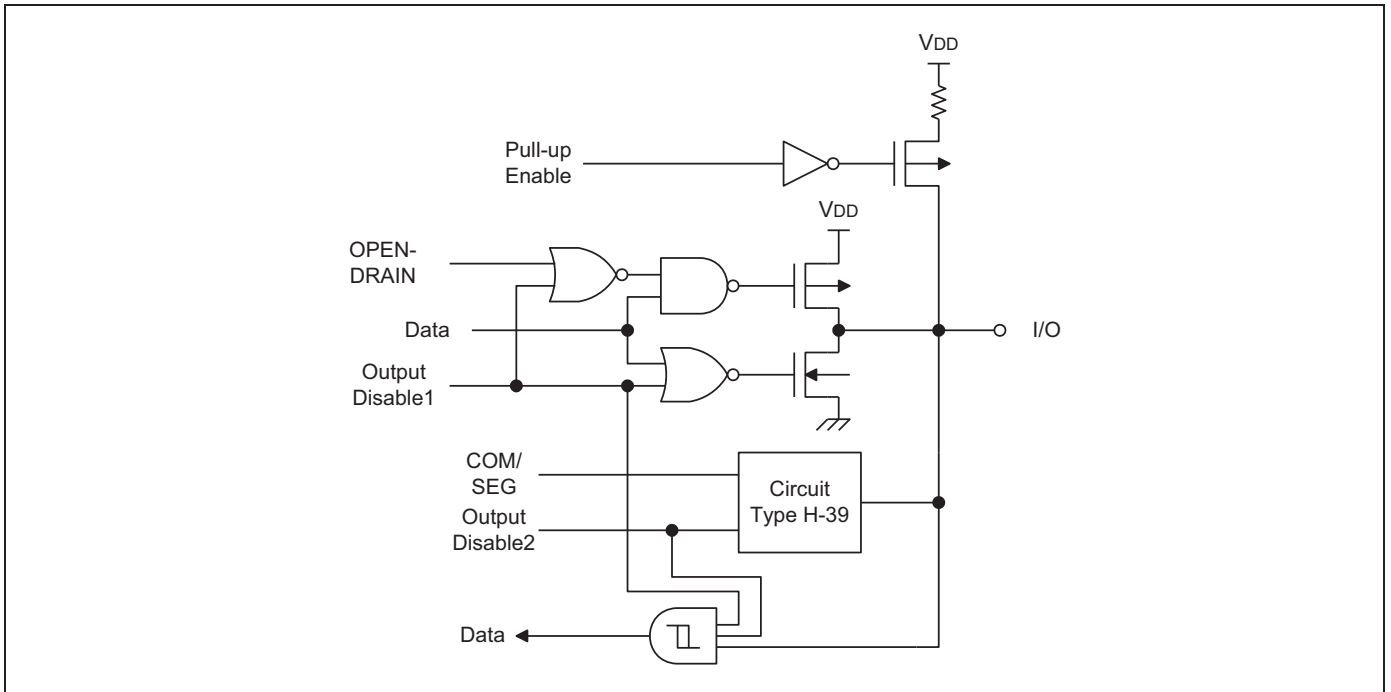


Figure 1-10 Pin Circuit Type H-41 (P3)

Figure 1-11 illustrates the pin circuit type H-42 (P4).

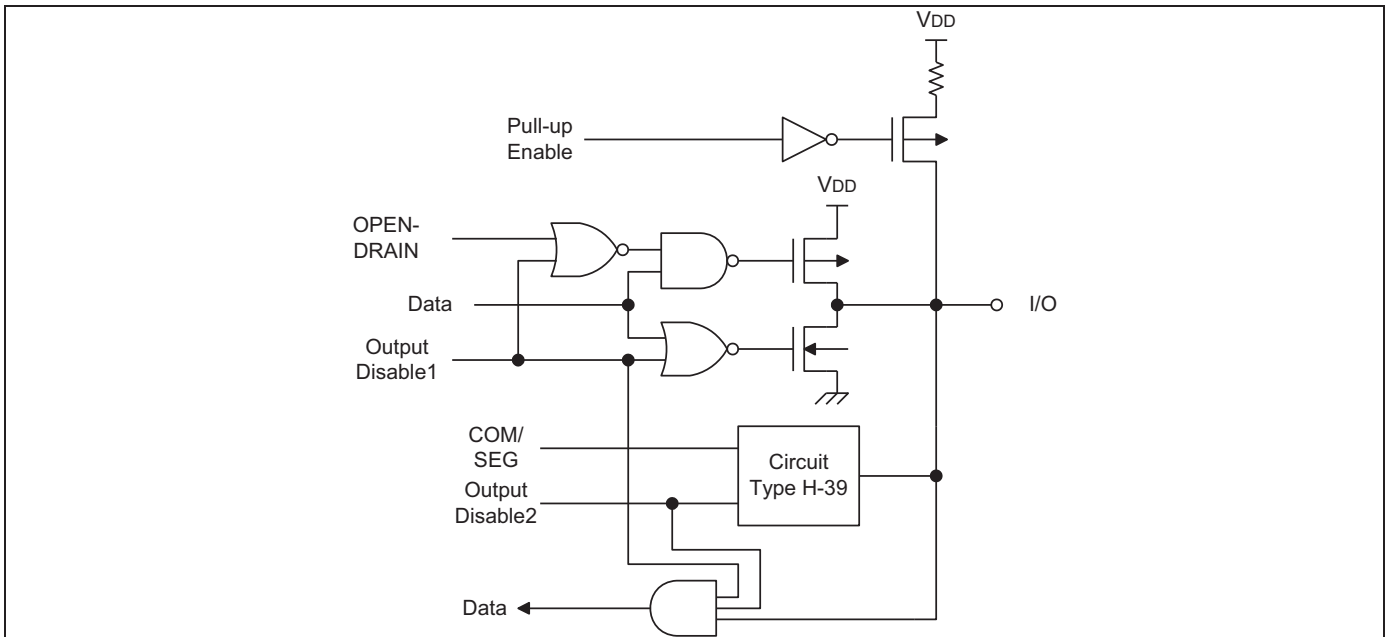


Figure 1-11 Pin Circuit Type H-42 (P4)

# 2 Address Spaces

## 2.1 Overview

The S3F8S19/F8S15 microcontroller consists of kinds of address spaces, namely:

- Internal program memory (Read only memory (ROM))
- Internal register file

A 16-bit address bus supports program memory operations. A separate 8-bit register bus transmits addresses and data between the CPU and the internal register file.

The S3F8S19/F8S15 microcontroller includes:

- 32/16 KB of on-chip program memory which is configured as the internal ROM mode.
- 2086 general-purpose registers in its internal register file. It maps 93 bytes in the register file for system and peripheral control functions.

## 2.2 Program Memory

Program memory (ROM) stores program codes or table data. S3F8S19/F8S15 microcontroller consists of 32/16 KB of internal multi-time programmable (MTP) program memory (Refer to [Figure 2-1](#) for more information.).

The first 256 bytes of the ROM (0H–0FFH) are reserved for interrupt vector addresses. Unused locations (except 3CH, 3DH, 3EH, 3FH) in this address range can be used as normal program memory. If you use the vector address area to store a program code, ensure not to overwrite the vector addresses stored in these locations.

3CH, 3DH, 3EH, 3FH is used as smart option ROM cell.

The default program reset address in the ROM is 0100H.

[Figure 2-1](#) illustrates the address space of program memory.

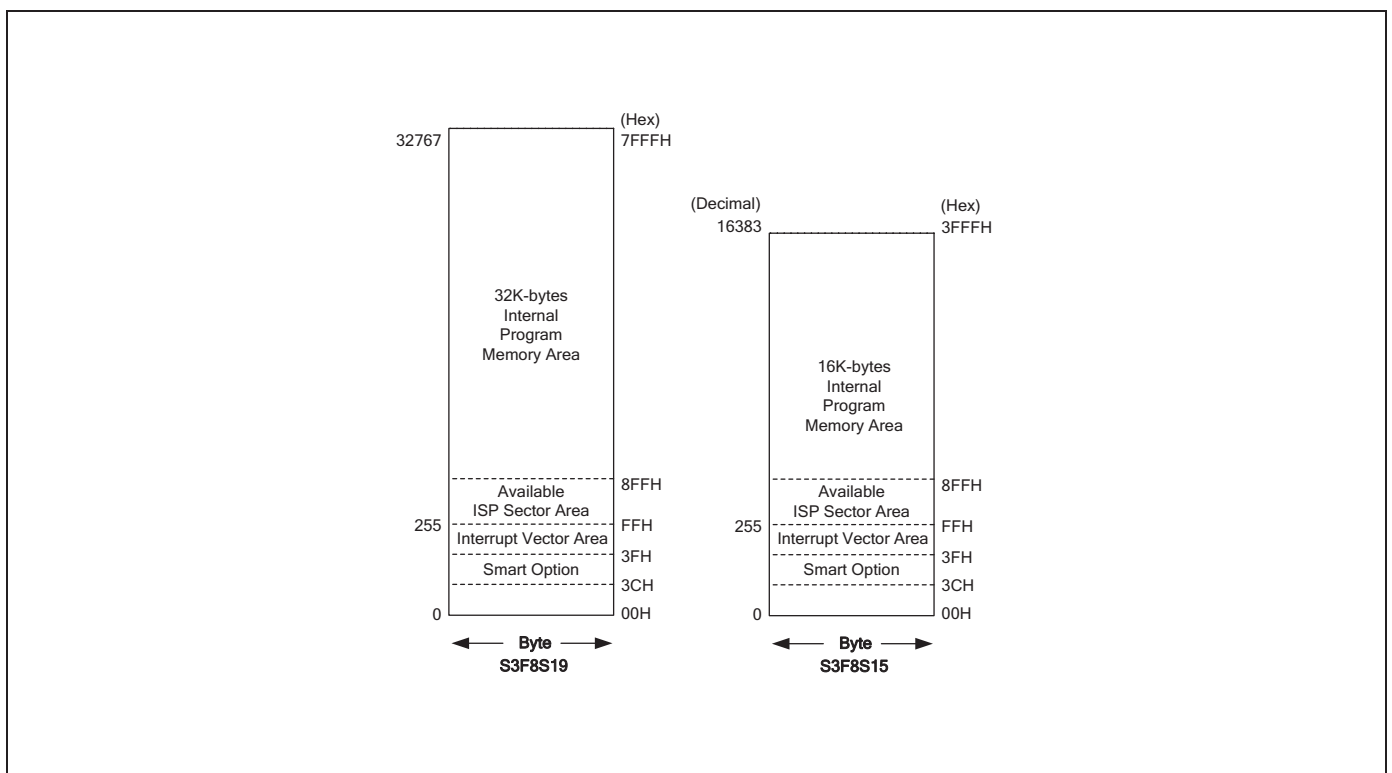


Figure 2-1 Program Memory Address Space

## 2.3 Smart Option

Figure 2-2 illustrates the smart option.

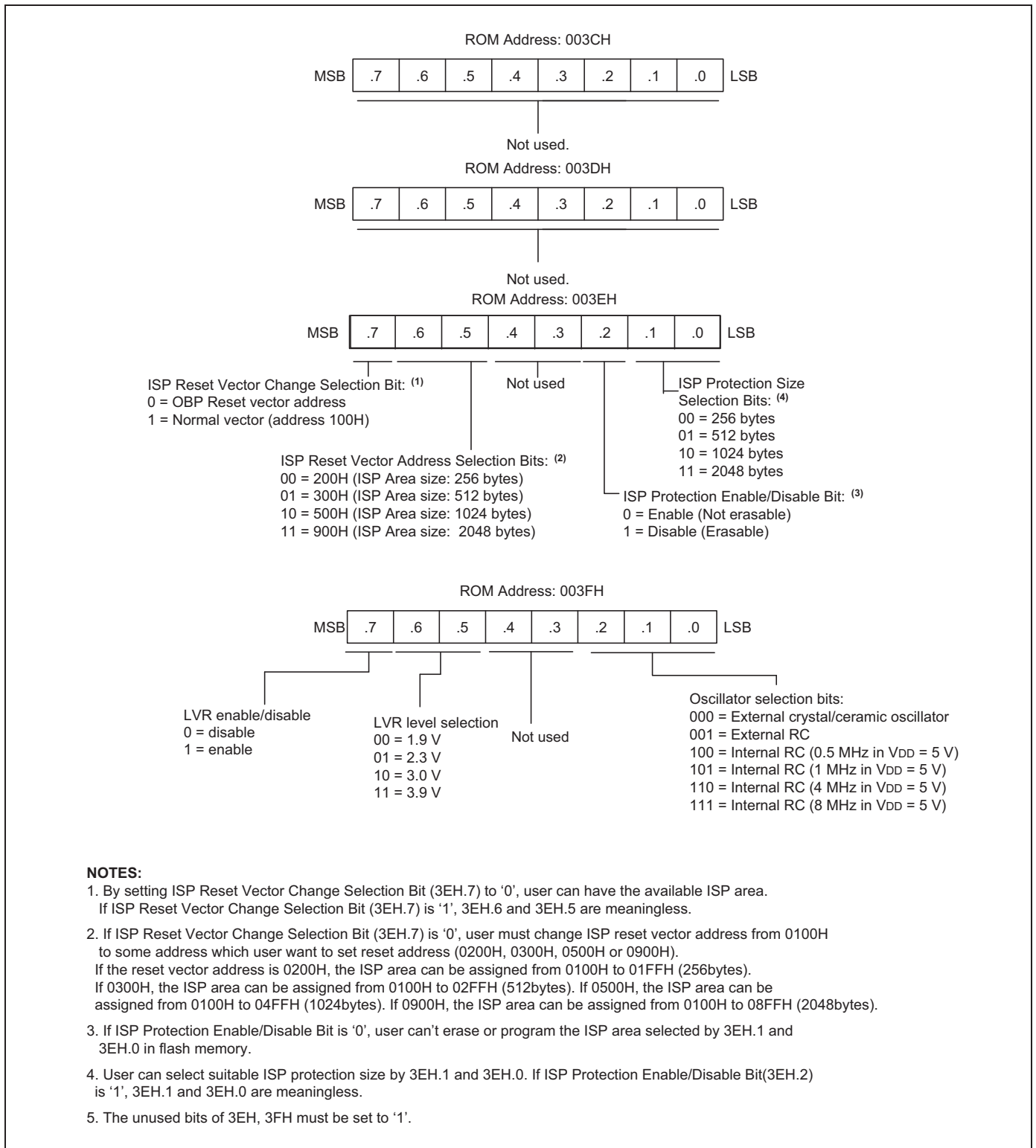


Figure 2-2 Smart Option



Smart Option is the ROM option for the start condition of the chip. The ROM address that Smart Option uses is from 003EH to 003FH. 003CH and 003DH are not used in S3F8S19/F8S15. 18

When any values that LDC instruction writes in the Smart Option area (003CH–003FH), it changes the data of the area. However, it does not affect the Smart Option. OTP/MTP programmer (Writer tools) should write the data for Smart Option in the Smart Option area.



## 2.4 Register Architecture

In the implementation of S3F8S19/F8S15 microcontroller, the upper 64 byte area of register files is expanded two 64 byte areas called set 1 and set 2. The upper 32 byte area of set 1 is further expanded two 32 byte register banks (bank 0 and bank 1), and the lower 32 byte area is a single 32 byte common area.

In case of S3F8S19/F8S15 microcontroller, the total number of addressable 8-bit registers is 2183.

Out of these 2183 registers:

- 13 bytes are for CPU and system control registers
- 84 bytes are for peripheral control and data registers
- 16 bytes are for shared working registers
- 2070 registers are for general-purpose use, page 0-page 8 (including 22 bytes for LCD display registers).

You can always address set 1 register locations, regardless of which of the two register pages is currently selected. However, you can address set 1 location by using register addressing modes.

Various addressing mode restrictions, the select bank instructions, SB0 and SB1, and the register page pointer (PP) support the extension of register space into separately addressable areas (sets, banks, and pages).

[Table 2-1](#) describes the specific register types and the area (in bytes) that they occupy in the register file.

**Table 2-1 S3F8S19/F8S15 Register Type Summary**

| Register Type  | Number of Bytes |
|--|-----------------|
| System and peripheral registers  | 93              |
| General-purpose registers<br>(including the 16-bit common working register area and LCD data register) | 2086            |
| Total addressable bytes  | 2183            |

Figure 2-3 illustrates internal register file organization (S3F8S19/F8S15).

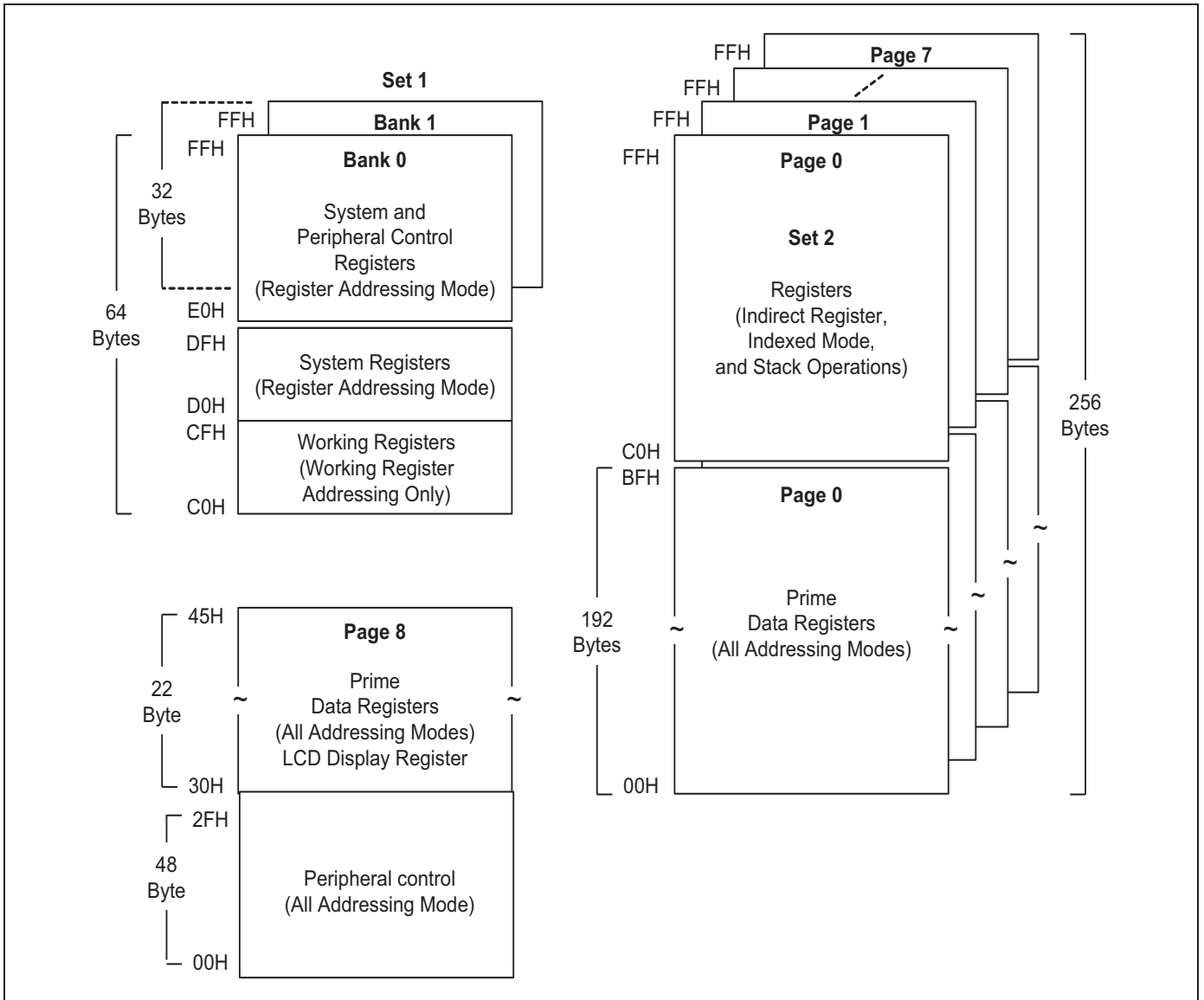


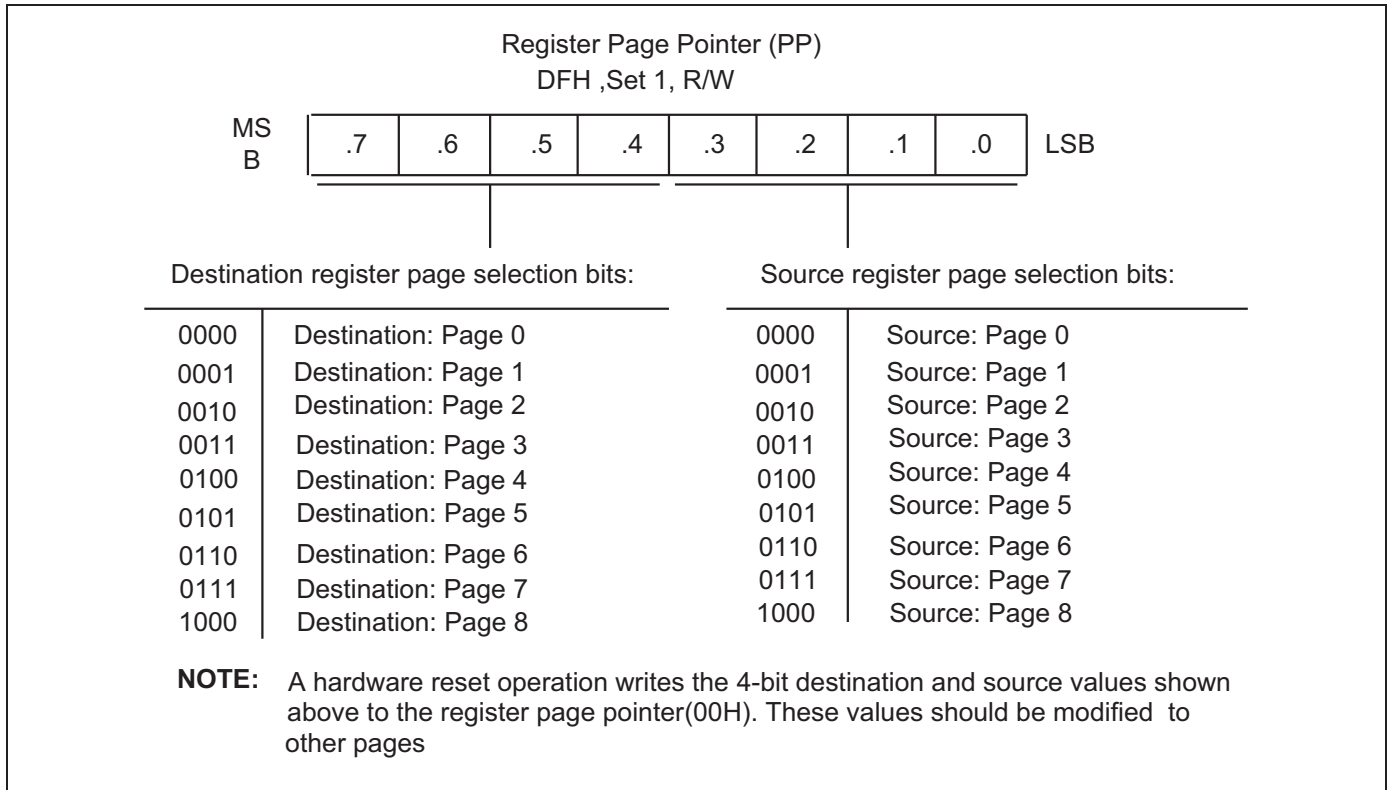
Figure 2-3 Internal Register File Organization (S3F8S19/F8S15)

## 2.5 Register Page Pointer

By using an 8-bit data bus, the S3F8-series architecture supports the logical expansion of the physical 256 byte internal register file into 16 separately addressable register pages. The register page pointer (PP, DFH) controls the page addressing

After a reset, the source value of PP (lower nibble) and the destination value (upper nibble) are always "0000", automatically selecting page 0 as the source and destination page for register addressing.

[Figure 2-4](#) illustrates the register PP.



**Figure 2-4 Register PP**



## 2.6 Register Set 1

The term set 1 refers to the upper 64 bytes of the register file, located at C0H–FFH.

The upper 32 byte area of this 64 byte space (E0H–FFH) is expanded two 32 byte register banks, bank 0 and bank 1. The set register bank instructions, SB0 or SB1, are used to address one bank or the other. A hardware reset operation always selects bank 0 addressing.

The upper two 32 byte areas (bank 0 and bank 1) of set 1 (E0H–FFH) contains 46 mapped system and peripheral control registers.

The lower 32 byte area contains 14 system registers (D0H–DFH) and a 16 byte common working register area (C0H–CFH).

You can use the common working register area as a "scratch" area for data operations being performed in other areas of the register file.

You can access the registers in set 1 location directly at any time by using register addressing mode. You can access the 16 byte working register area by using working register addressing only (Refer to Chapter 3 "Addressing Modes" for more information about working register addressing).

## 2.7 Register Set 2

The same 64 byte physical space that is used for set 1 location C0H to FFH is logically duplicated to add another 64 bytes of register space. This expanded area of the register file is called set 2. For S3F8S19/F8S15 microcontroller, you can access the set 2 address range (C0H–FFH) on RAM page 0-page 7.

Addressing mode restriction maintains the logical division of set 1 and set 2. You can use only addressing mode register to access set 1 location. To access registers in set 2, use indirect addressing mode or Indexed addressing mode register.

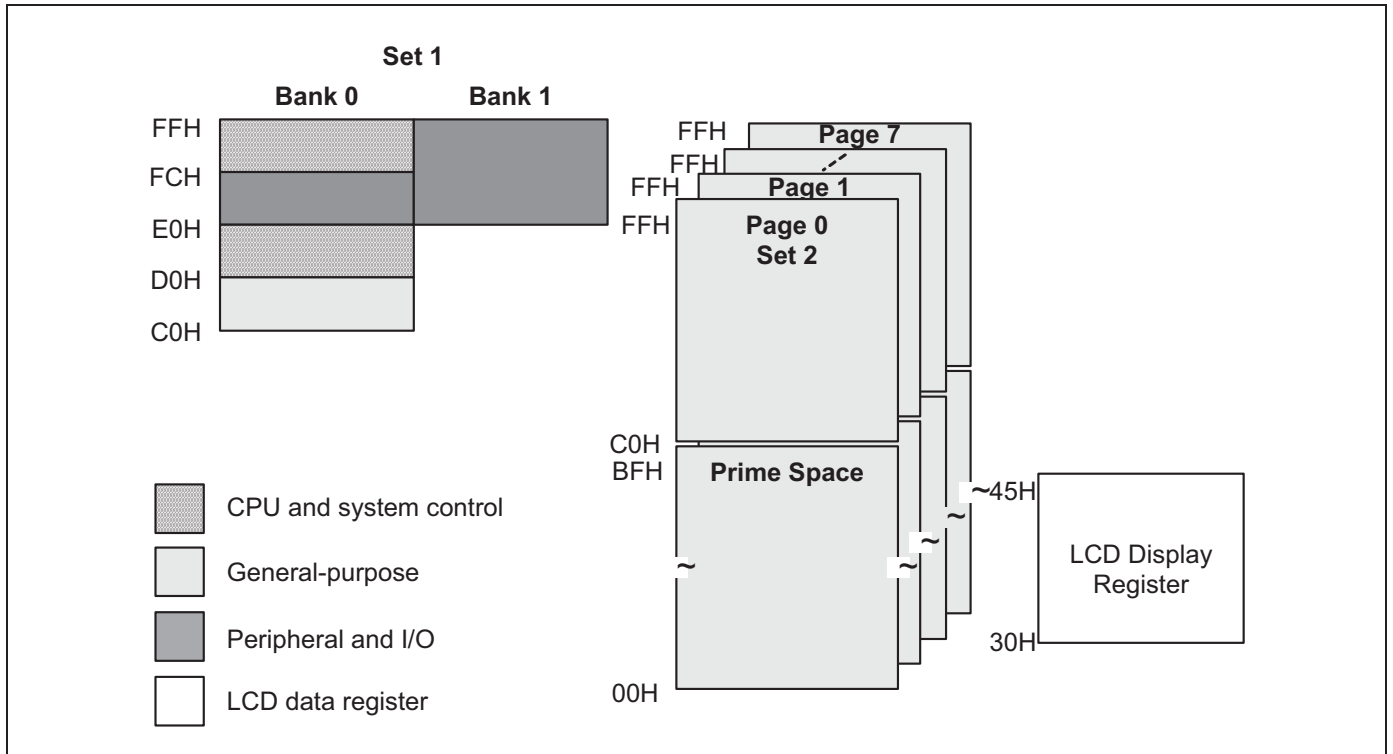
The set 2 register area is commonly used for stack operations.

## 2.8 Prime Register Space

The lower 192 bytes (00H–BFH) of the S3F8S19/F8S15's 256 byte register pages is called prime register area. You can access prime registers by using any of the seven addressing modes. Refer to Chapter 3 "Addressing Modes" for more information.

It addresses the prime register area on page 0 immediately after a reset. To address prime registers on pages 0, 1, 2, 3, 4, 5, 6, and 7, you should set the register PP to the appropriate source and destination values.

[Figure 2-5](#) illustrates the set 1, set 2, prime area register map, and LCD data register map.



**Figure 2-5 Set 1, Set 2, Prime Area Register Map and LCD Data Register Map**

## 2.9 Working Registers

Instructions can access specific 8-bit registers or 16-bit register pairs by using either 4-bit or 8-bit address fields. When it uses 4-bit working register addressing, the programmer can see the 256 byte register file that consists of thirty-two 8 byte register groups or "slices." Each slice consists of eight 8-bit registers.

Using the two 8-bit register pointers, RP1 and RP0, you can select the two working register slices at any time to form a 16 byte working register block. By using the register pointers, you can move this 16 byte register block anywhere in the addressable register file, except the set 2 area.

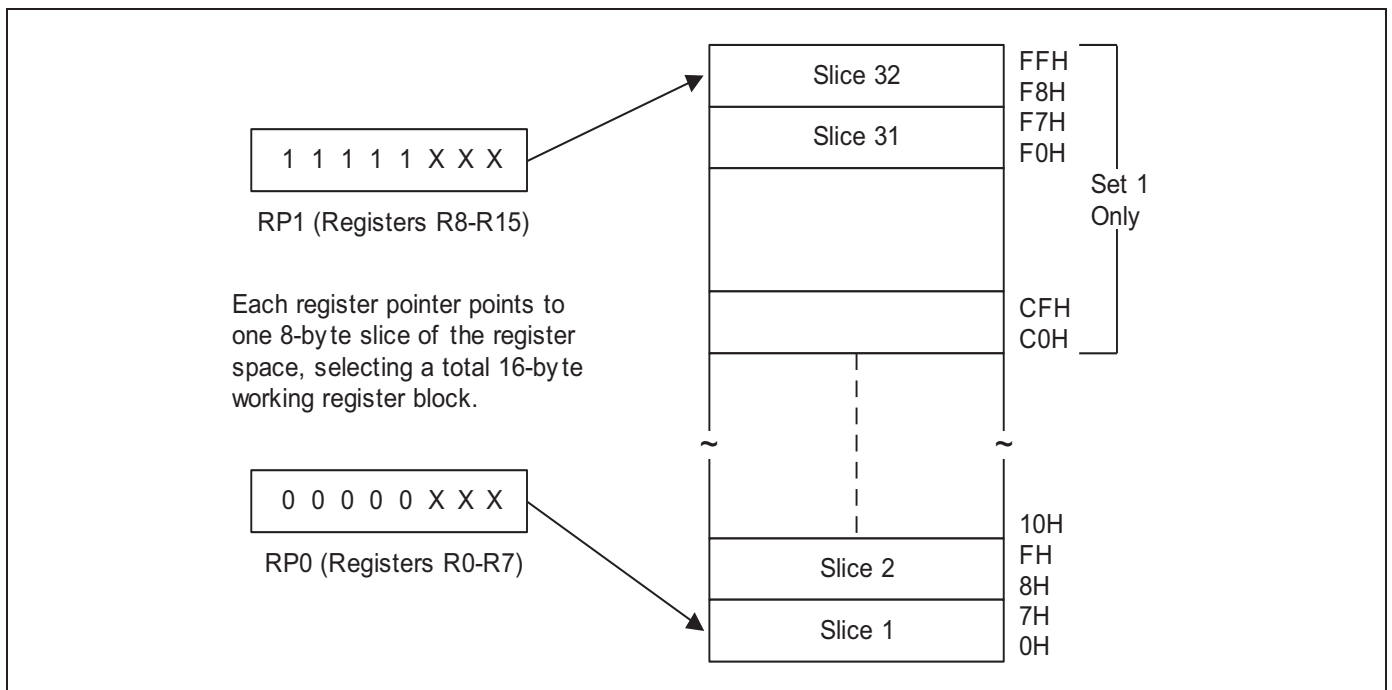
The terms "slice" and "block" helps to visualize the size and relative locations of selected working register spaces:

- One working register slice is 8 bytes (eight 8-bit working registers, R0–R7 or R8–R15)
- One working register block is 16 bytes (sixteen 8-bit working registers, R0–R15)

All the registers in an 8 byte working register slice have similar binary values for their five most significant address bits. This makes it possible for each register pointer to point to one of the 24 slices in the register file. The base addresses for the two selected 8-byte register slices are contained in register pointers RP0 and RP1.

After a reset, RP0 and RP1 always point to the 16 byte common area in set 1 (C0H–CFH).

[Figure 2-6](#) illustrates 8 byte working register areas (slices)



**Figure 2-6 8 Byte Working Register Areas (Slices)**

## 2.10 Using the Register Points

It uses register pointers RP0 and RP1 that it maps to address D6H and D7H in set 1 to select two movable 8-byte working register slices in the register file. After a reset, they point to the working register common area: RP0 points to addresses C0H–C7H, and RP1 points to addresses C8H–CFH.

To change a register pointer value, load a new value to RP0 and/or RP1 by using an SRP or LD instruction. (Refer to [Figure 2-7](#) and [Figure 2-8](#) for more information).

With working register addressing, you can only access those two 8-bit slices of the register file that are currently pointed to by RP0 and RP1. However, you cannot use the register pointers to select a working register space in set 2, C0H–FFH because you can access these locations only by using the indirect register or indexed addressing modes.

The selected 16-byte working register block usually consists of two contiguous 8 byte slices. As a general programming guideline, RP0 should point to the "lower" slice and RP1 should point to the "upper" slice (Refer to [Figure 2-8](#) for more information). In some cases, it may be necessary to define working register areas in different (non-contiguous) areas of the register file. In [Figure 2-8](#), RP0 points to the "upper" slice and RP1 to the "lower" slice.

With the register pointer pointing to either of the two 8 byte slices in the working register block, you can flexibly define the working register area to support program requirements.

[Example 2-1](#) shows register pointer setting.

### Example 2-1 Setting the Register Pointers

```

SRP    #70H           ; RP0 ← 70H, RP1 ← 78H
SRP1   #48H           ; RP0 ← no change, RP1 ← 48H
SRP0   #0A0H         ; RP0 ← A0H, RP1 ← no change
CLR    RP0            ; RP0 ← 00H, RP1 ← no change
LD     RP1, #0F8H     ; RP0 ← no change, RP1 ← 0F8H
    
```

[Figure 2-7](#) illustrates contiguous 16 byte working register block.

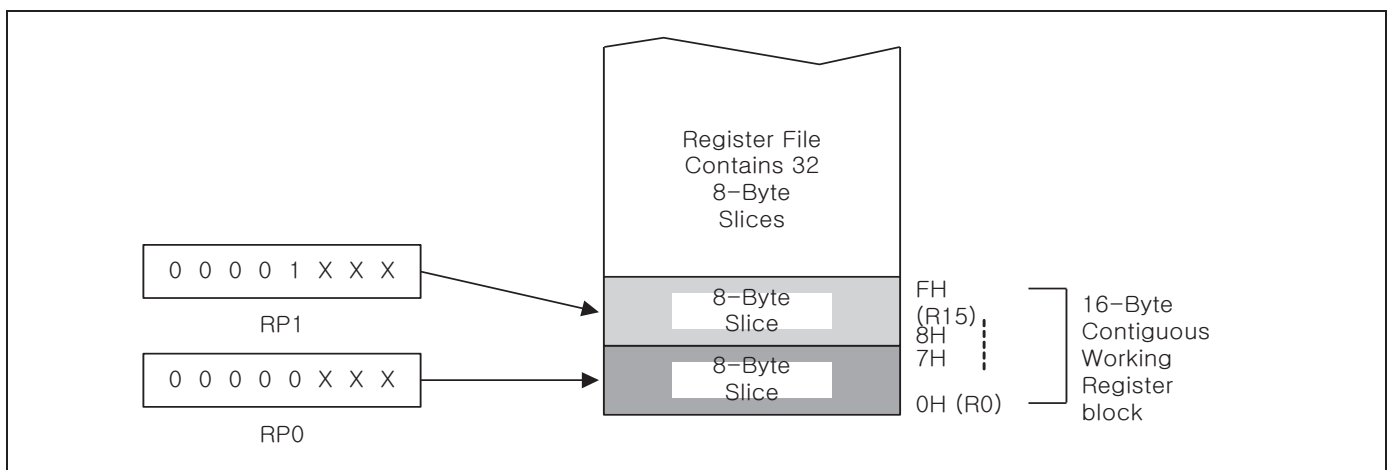
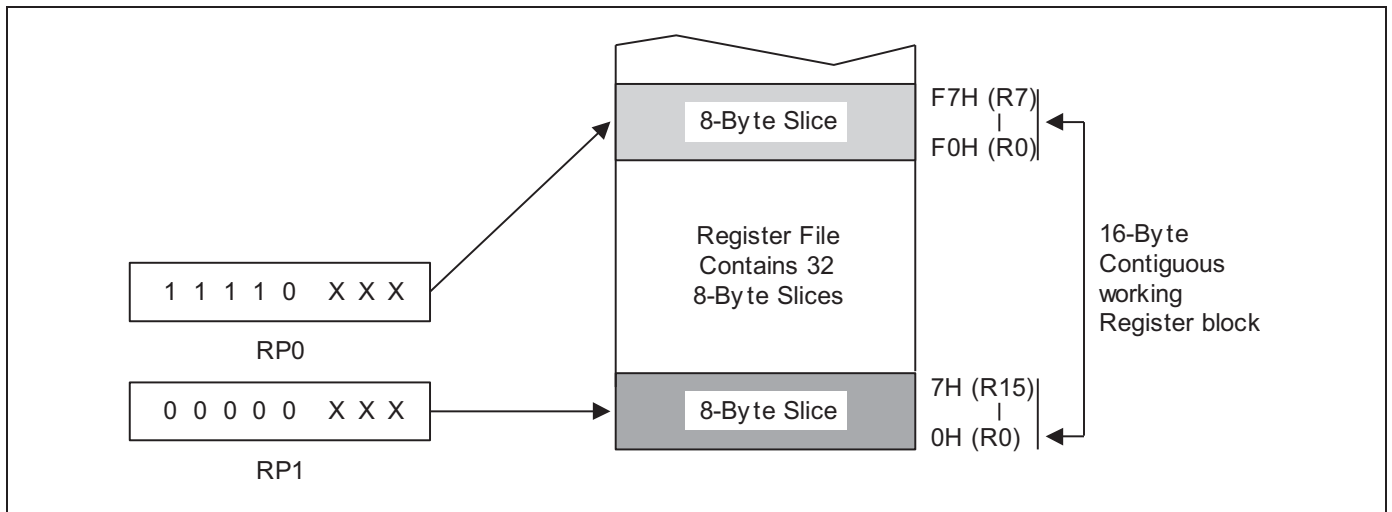


Figure 2-7 Contiguous 16 Byte Working Register Block

Figure 2-8 illustrates the non-contiguous 16 byte working register block.



**Figure 2-8 Non-Contiguous 16 Byte Working Register Block**

Example 2-2 shows how to use the RPs to calculate the sum of a series of registers.

**Example 2-2 Using the RPs to Calculate the Sum of a Series of Registers**

Calculate the sum of registers 80H-85H by using the register pointer. The register addresses from 80H through 85H contain the values 10H, 11H, 12H, 13H, 14H, and 15 H, respectively:

```

SRP0  #80H          ; RP0 ← 80H
ADD   R0, R1        ; R0 ← R0 + R1
ADC   R0, R2        ; R0 ← R0 + R2 + C
ADC   R0, R3        ; R0 ← R0 + R3 + C
ADC   R0, R4        ; R0 ← R0 + R4 + C
ADC   R0, R5        ; R0 ← R0 + R5 + C
    
```

The sum of these six registers, 6FH, is located in the register R0 (80H). The instruction string that it uses in this example takes 12 bytes of instruction code and its execution time is 36 cycles. If the register pointer is not used to calculate the sum of these registers, the following instruction sequence would have to be used:

```

ADD   80H, 81H      ; 80H ← (80H) + (81H)
ADC   80H, 82H      ; 80H ← (80H) + (82H) + C
ADC   80H, 83H      ; 80H ← (80H) + (83H) + C
ADC   80H, 84H      ; 80H ← (80H) + (84H) + C
ADC   80H, 85H      ; 80H ← (80H) + (85H) + C
    
```

Now, the sum of the six registers is also located in register 80H. However, this instruction string takes 15 bytes of instruction code rather than 12 bytes and its execution time is 50 cycles rather than 36 cycles.

## 2.11 Register Addressing

The S3C8-series register architecture provides an efficient method of working register addressing. This takes full advantage of shorter instruction formats to reduce execution time.

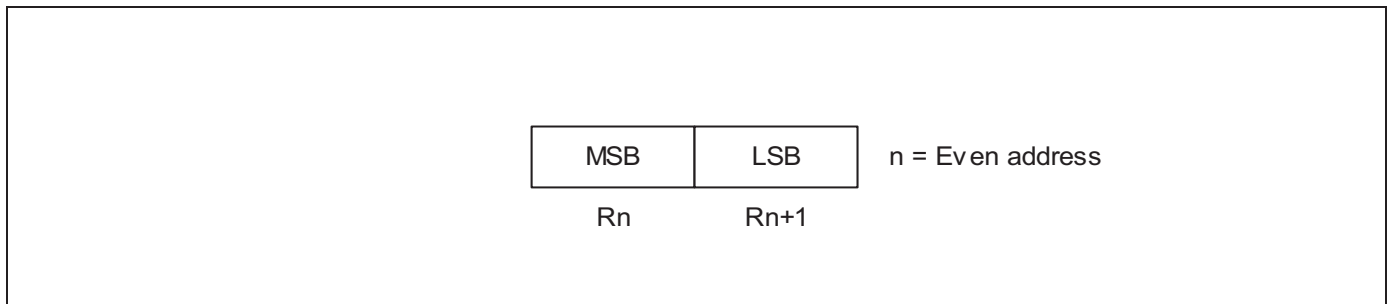
With Register (R) addressing mode, in which the operand value is the content of a specific register or register pair, you can access any location in the register file except for set 2. With working register addressing, you use:

- A register pointer to specify an 8 byte working register space in the register file
- An 8-bit register within that space

You can address the registers either as a single 8-bit register or as a paired 16-bit register space. In a 16-bit register pair, the address of the first 8-bit register is always an even number and the address of the next register is always an odd number. The most significant byte of the 16-bit data is always stored in the even-numbered register, and the least significant byte is always stored in the next (+ 1) odd-numbered register.

Working register addressing is different from register addressing as it uses a register pointer to identify a specific 8 byte working register space in the internal register file and a specific 8-bit register within that space.

[Figure 2-9](#) illustrates the 16-bit register pair.



**Figure 2-9 16-Bit Register Pair**

Figure 2-10 illustrates the register file addressing.

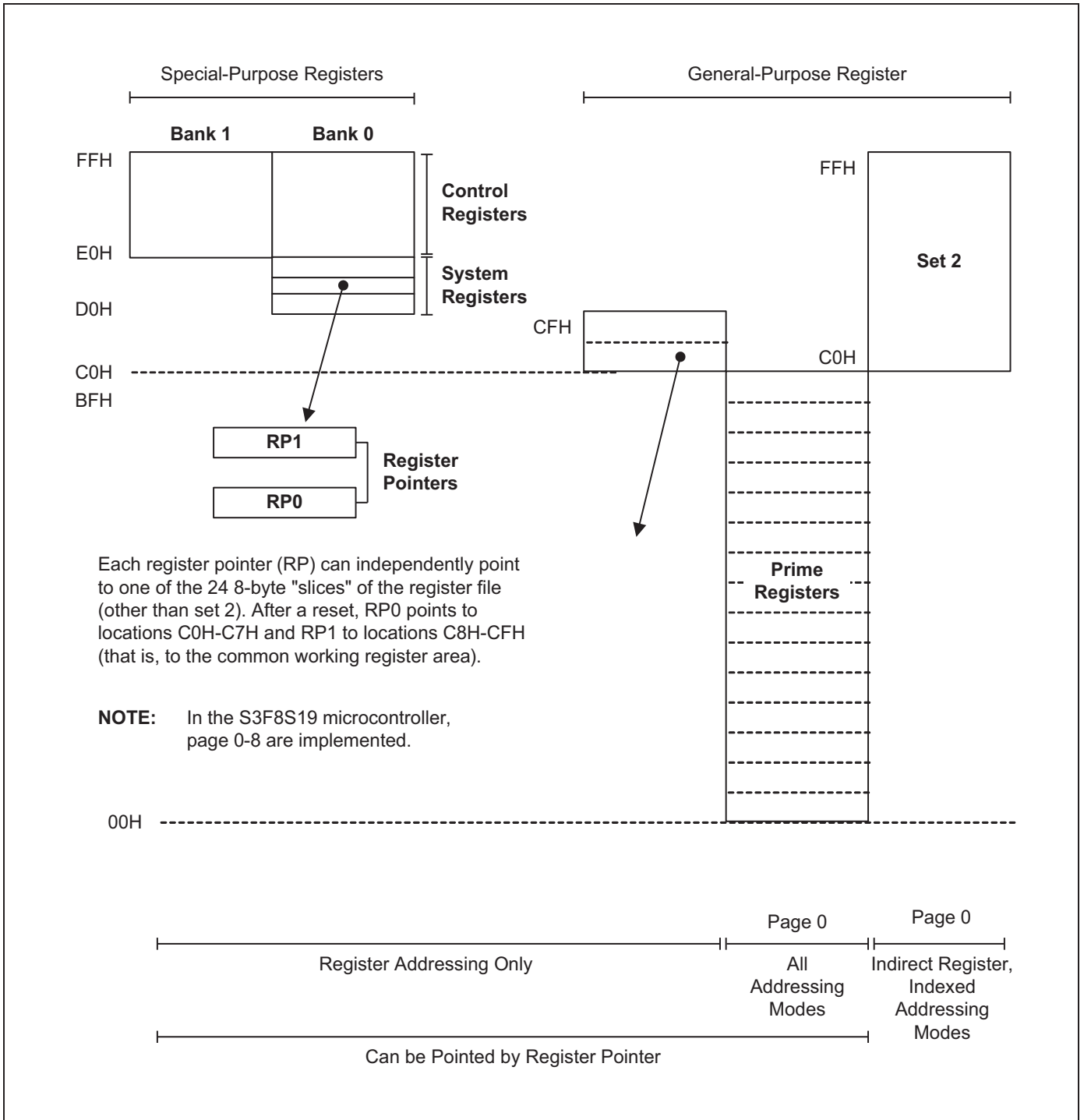


Figure 2-10 Register File Addressing

## 2.12 Common Working Register Area (C0H–CFH)

After a reset, register pointers, RP0 and RP1 automatically select two 8 byte register slices in set 1; locations C0H–CFH, as the active 16 byte working register block. These register slices are:

- RP0 → C0H–C7H
- RP1 → C8H–CFH

This 16 byte address range is called common area. That is, you can use locations in this area as working registers. This occurs by operating that address any location on any page in the register file. Generally, these working registers serve as temporary buffers for data operations between different pages.

[Figure 2-11](#) illustrates the common working register area.

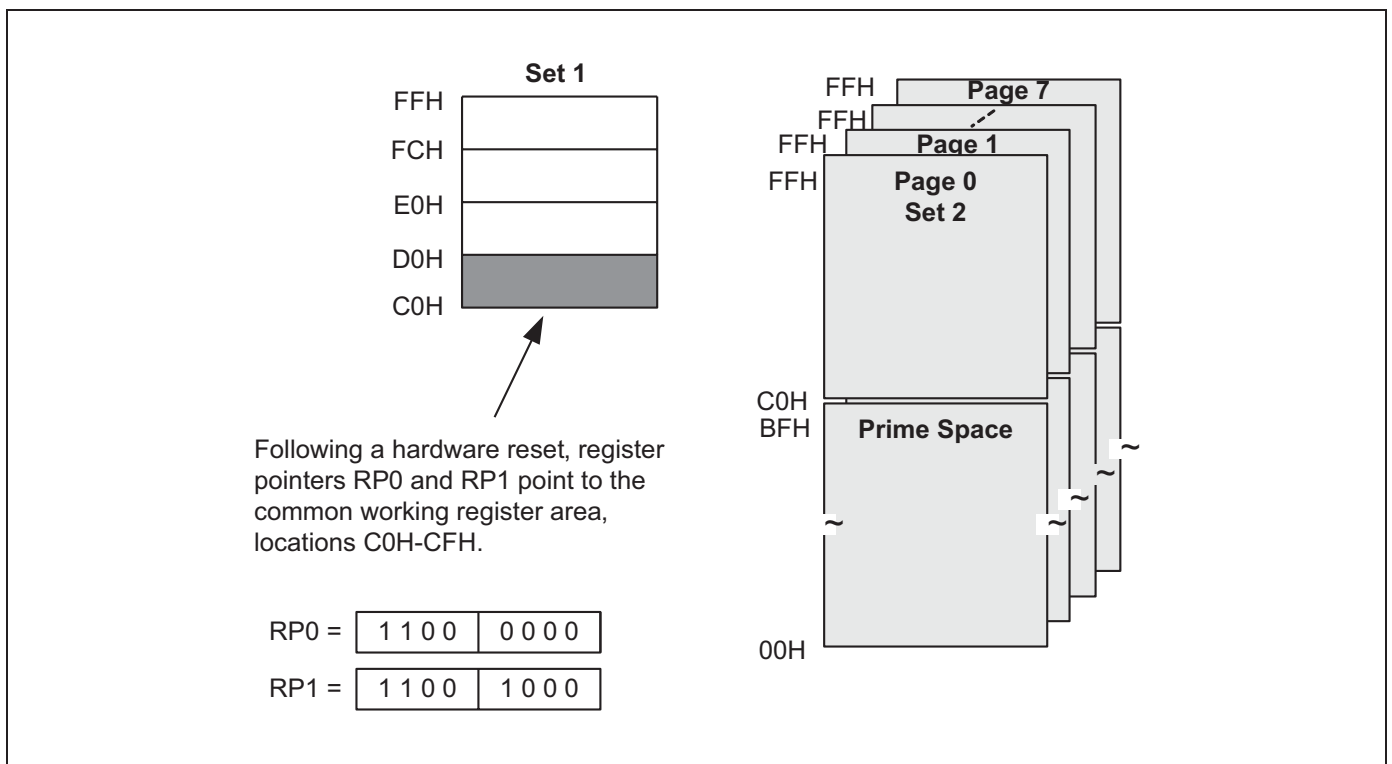


Figure 2-11 Common Working Register Area



[Example 2-3](#) shows addressing the common working register area.

### Example 2-3 Addressing the Common Working Register Area

As shown in this example, you should access working registers in the common area, locations C0H–CFH, by using working register addressing mode only.

Examples 1:

```
LD      0C2H, 40H                ; Invalid addressing mode!
```

Use working register addressing instead:

```
SRP     #0C0H
```

```
LD      R2, 40H                ; R2 (C2H) ← the value in location 40H
```

Examples 2:

```
ADD     0C3H, #45H             ; Invalid addressing mode!
```

Use working register addressing instead:

```
SRP     #0C0H
```

```
ADD     R3, #45H              ; R3 (C3H) ← R3 + 45H
```

### 2.13 4-Bit Working Register Addressing

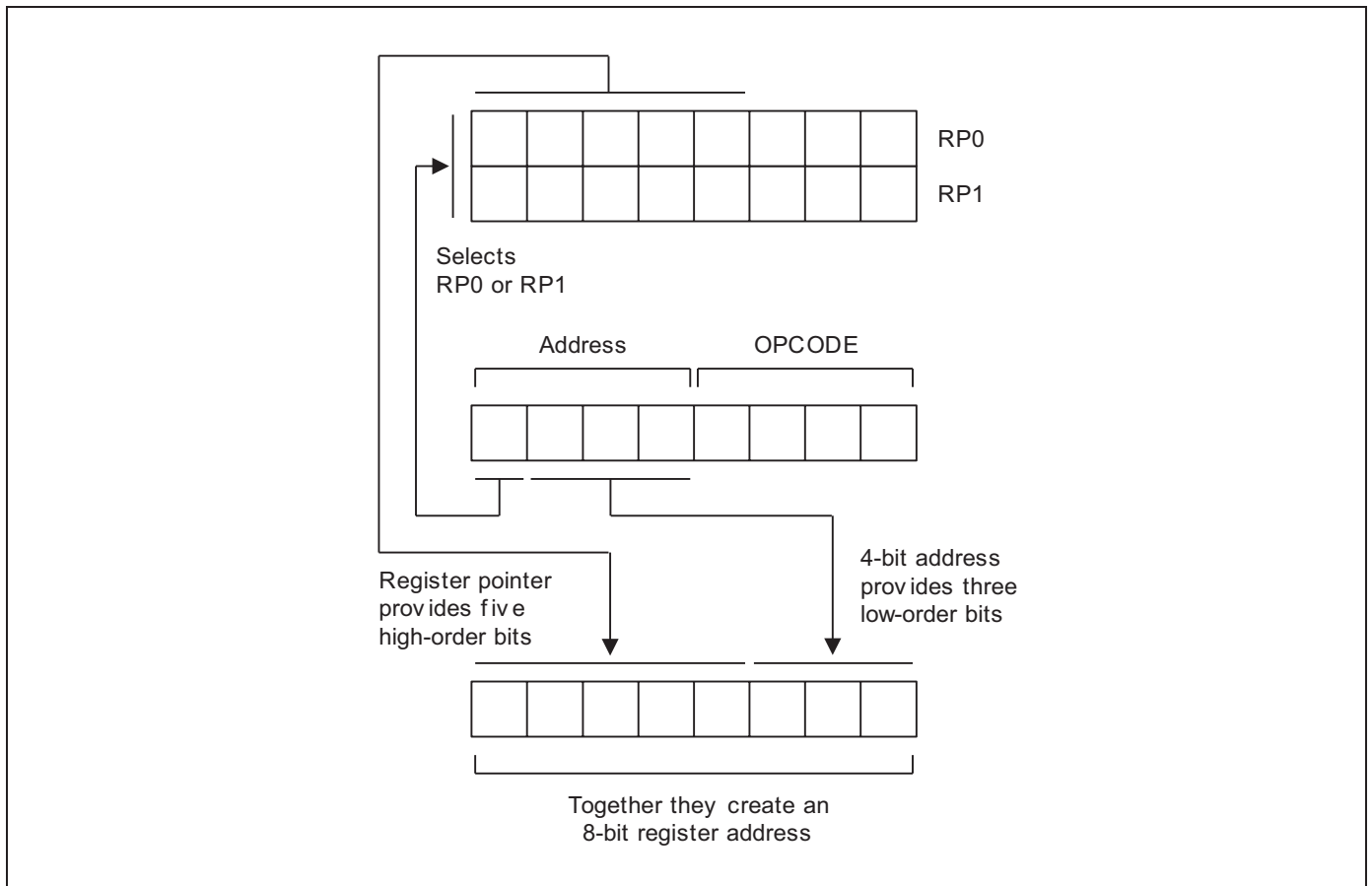
Each register pointer defines a movable 8 byte slice of working register space. The address information stored in a register pointer serves as an addressing "window." This makes it possible for instructions to access working registers efficiently by using short 4-bit addresses. When an instruction addresses a location in the selected working register area, it concatenates the address bits in this manner to form a complete 8-bit address:

- The high-order bit of the 4-bit address selects one of the register pointers ("0" selects RP0, "1" selects RP1).
- The five high-order bits in the register pointer select an 8 byte slice of the register space.
- The three low-order bits of the 4-bit address select one of the eight registers in the slice.

As illustrated in [Figure 2-12](#), it concatenates the result of this operation is that the five high-order bits from the register pointer with the three low-order bits from the instruction address to form the complete address. As long as the address that it stores in the register pointer remains unchanged, the three bits from the address always points to an address in the same 8-byte register slice.

[Figure 2-13](#) illustrates a typical example of 4-bit working register addressing. The high-order bit of the instruction "INC R6" is "0", which selects RP0. It concatenates the five high-order bits that it stores in RP0 (01110B) with the three low-order bits of the instruction's 4-bit address (110B) to produce the register address 76H (01110110B).

[Figure 2-12](#) illustrates the 4-bit working register addressing.



**Figure 2-12 4-Bit Working Register Addressing**

Figure 2-13 illustrates the 4-bit working register addressing example.

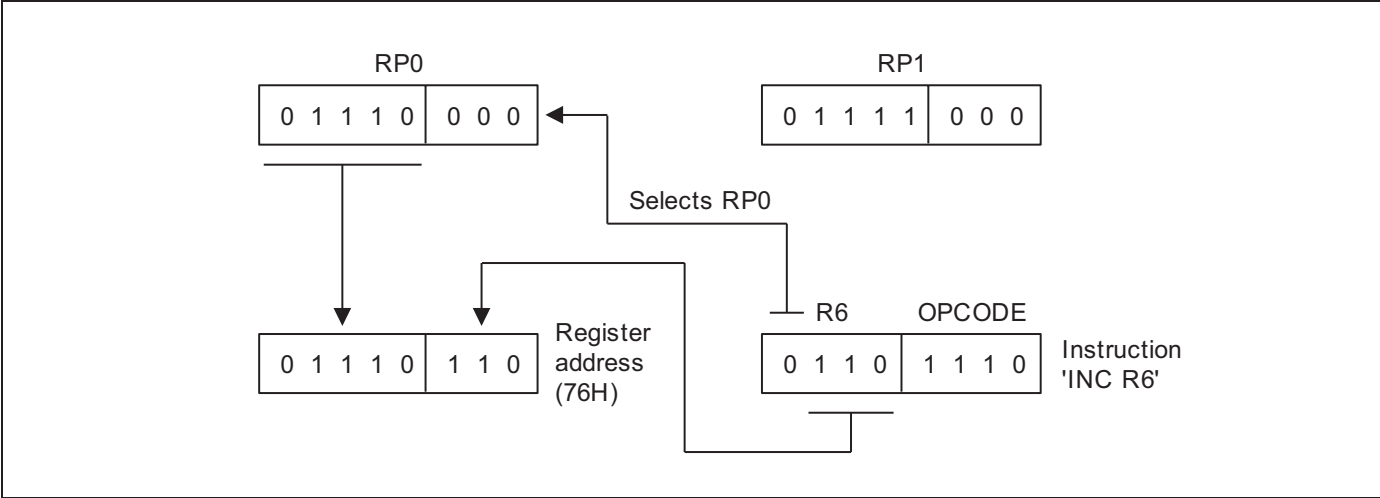


Figure 2-13 4-Bit Working Register Addressing Example

## 2.14 8-Bit Working Register Addressing

You can also use 8-bit working register addressing to access registers in a selected working register area. To initiate 8-bit working register addressing, the upper four bits of the instruction address should contain the 4-bit value, "1100B." This value indicates that the remaining four bits have the same effect as 4-bit working register addressing.

As [Figure 2-14](#) illustrates, it concatenates the lower nibble of the 8-bit address in similar manner as for 4-bit addressing: Bit 3 selects either RP0 or RP1, which then supplies the five high-order bits of the final address. The original instruction provides the three low-order bits of the complete address.

[Figure 2-15](#) illustrates an example of 8-bit working register addressing. The four high-order bits of the instruction address (1100B) specify 8-bit working register addressing. Bit 4 ("1") selects RP1 and the five high-order bits in RP1 (10101B) turn into the five high-order bits of the register address.

The three low-order bits of the 8-bit instruction address provide the three low-order bits of the register address (011). It concatenates the five address bits from RP1 and the three address bits from the instruction to form the complete register address, 0ABH (10101011B).

[Figure 2-14](#) illustrates the 8-bit working register addressing.

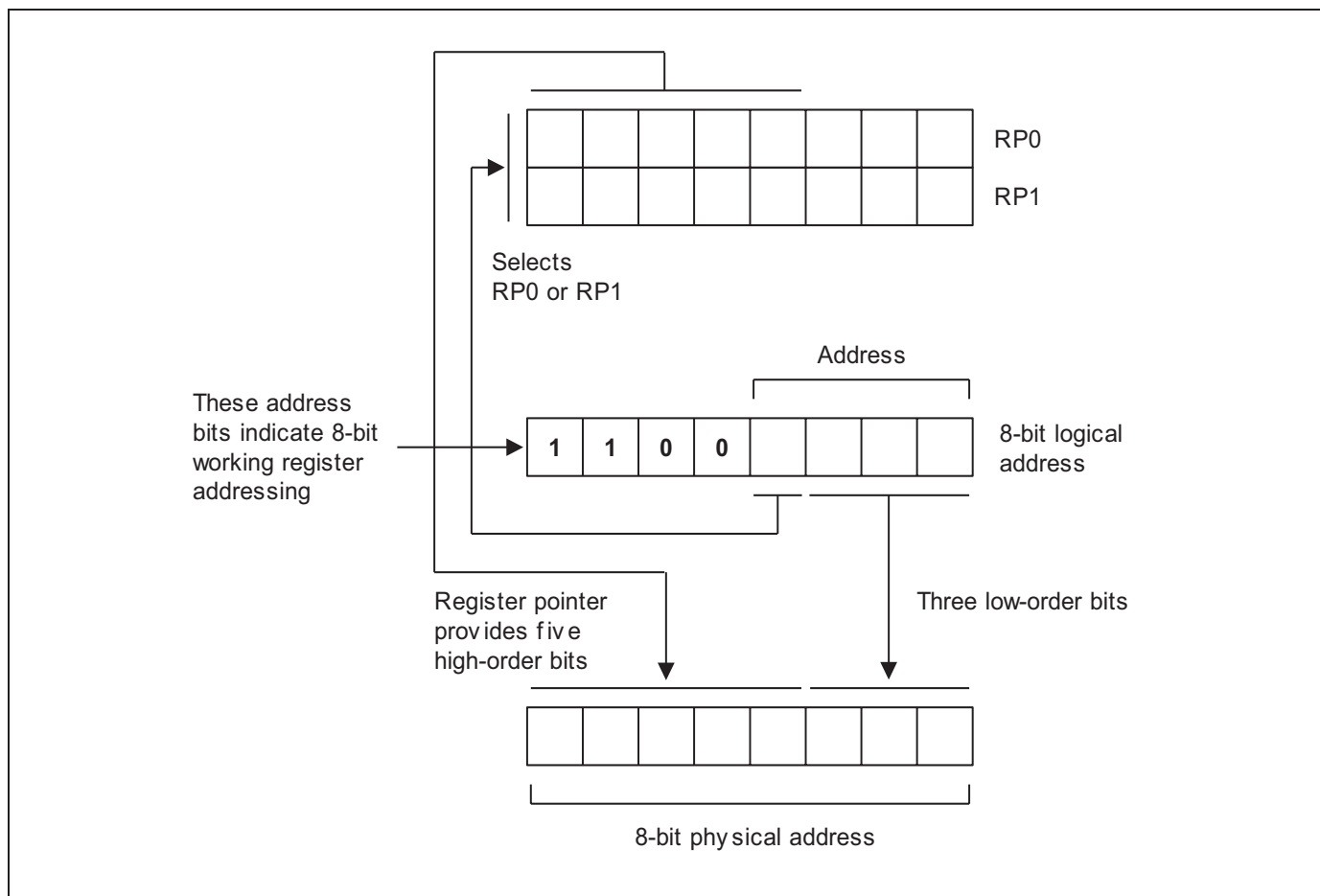


Figure 2-14 8-Bit Working Register Addressing

Figure 2-15 illustrates the 8-Bit working register addressing example.

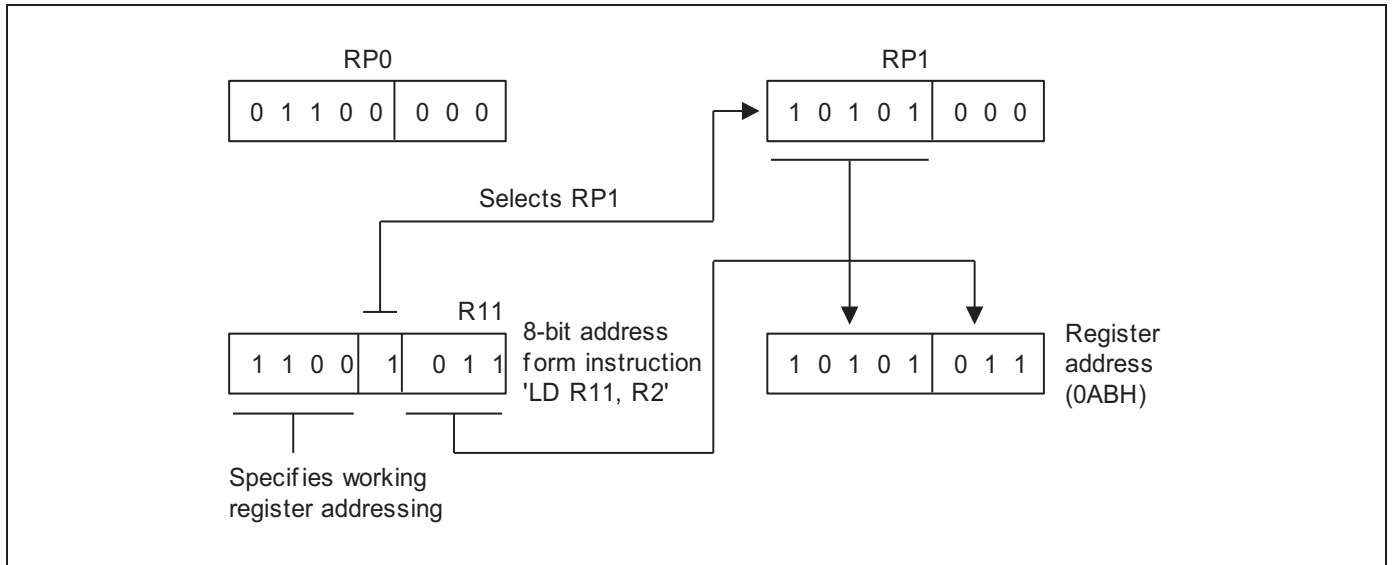


Figure 2-15 8-Bit Working Register Addressing Example

## 2.15 System and User Stack

The S3C8-series microcontrollers use the system stack for data storage, subroutine calls, and returns. The PUSH and POP instructions are used to control system stack operations. The S3F8S19/F8S15 architecture supports stack operations in the internal register file.

### 2.15.1 Stack Operations

It stores return addresses for procedure calls, interrupts, and data on the stack. A CALL instruction saves the contents of the PC to stack and RET instruction restores it. When an interrupt occurs, it pushes the contents of the PC and the FLAGS register to the stack. The IRET instruction then pops these values back to their original locations. It always decreases the stack address value by one before a push operation and increases by one after a pop operation. The stack pointer (SP) always points to the stack frame that it stores on the top of the stack, as illustrated in [Figure 2-16](#).

[Figure 2-16](#) illustrates the stack operations.

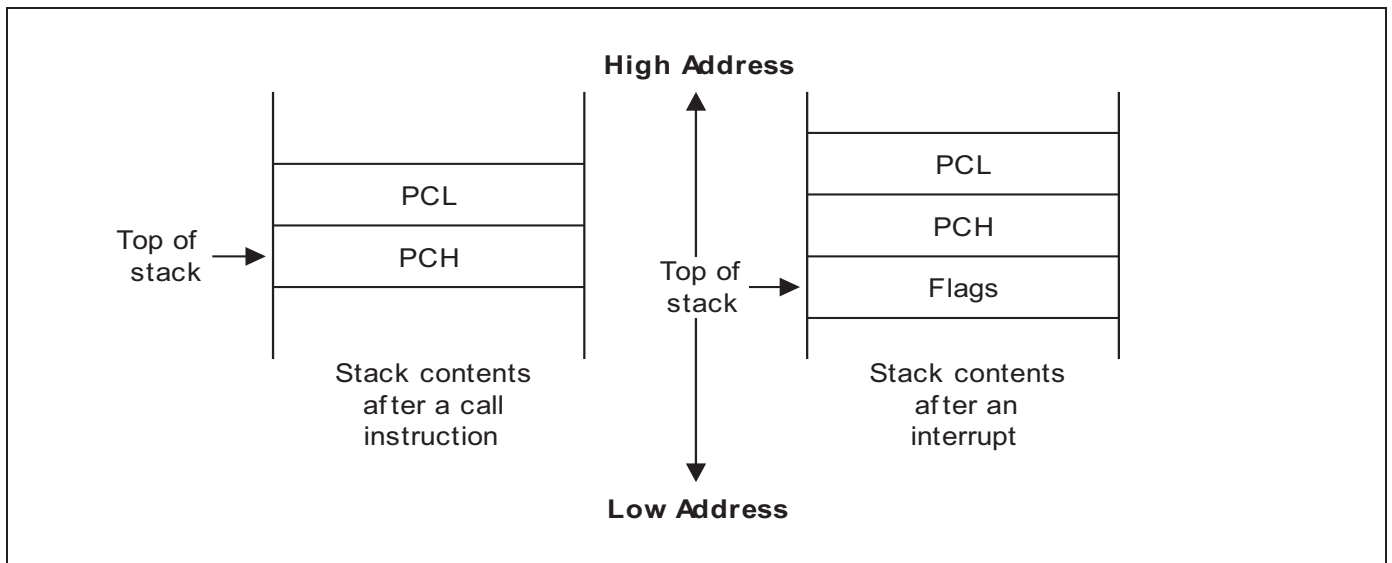


Figure 2-16 Stack Operations

### 2.15.2 User-Defined Stacks

You can define stacks in the internal register file as data storage locations. The instructions PUSHUI, PUSHUD, POPUI, and POPUD support user-defined stack operations.

### 2.15.3 Stack Pointers (SPL, SPH)

Register locations D8H and D9H contain the 16-bit SP that it uses for system stack operations. The most significant byte of the SP address, SP15–SP8, is stored in the SPH register (D8H), and the least significant byte, SP7–SP0, is stored in the SPL register (D9H). After a reset, the SP value is undetermined.

Because it only implements internal memory space in the S3F8S19/F8S15 microcontroller, it must initialize the SPL to an 8-bit value in the range 00H–FFH. The SPH register is not needed and it can use it as a general-purpose register, if necessary.

When the SPL register contains only the SP value (that is, when it points to a system stack in the register file), you can use the SPH register as a general-purpose data register.

However, if an overflow or underflow condition occurs as a result of increasing or decreasing the stack address value in the SPL register during normal stack operations, the value in the SPL register overflows (or underflows) to the SPH register. This occurs by overwriting any other data that is currently stored there. To avoid overwriting data in the SPH register, you can initialize the SPL value to "FFH" instead of "00H".

[Example 2-4](#) shows how to perform stack operations in the internal register file by using PUSH and POP instructions:

#### Example 2-4 Standard Stack Operations Using PUSH and POP

```
LD    SPL, #0FFH    ; SPL ← FFH
                        ; (Normally, the SPL is set to 0FFH by the initialization routine)
.
.
.
PUSH  PP            ; Stack address 0FEH ← PP
PUSH  RP0           ; Stack address 0FDH ← RP0
PUSH  RP1           ; Stack address 0FCH ← RP1
PUSH  R3            ; Stack address 0FBH ← R3
.
.
.
POP   R3            ; R3 ← Stack address 0FBH
POP   RP1           ; RP1 ← Stack address 0FCH
POP   RP0           ; RP0 ← Stack address 0FDH
POP   PP            ; PP ← Stack address 0FEH
```

# 3 Addressing Modes

## 3.1 Overview

Instructions are stored in program memory are fetched for execution by using the program counter. Instructions indicate the operation to be performed and the data to be operated on. Addressing mode is the method used to determine the location of the data operand. The operands specified in SAM8RC instructions may be condition codes, immediate data, or a location in the register file, program memory, or data memory.

The S3C-series instruction set supports seven explicit addressing modes.

Not all of these addressing modes are available for each instruction.

The seven addressing modes and their symbols are:

- Register (R)
- Indirect Register (IR)
- Indexed (X)
- Direct Address (DA)
- Indirect Address (IA)
- Relative Address (RA)
- Immediate (IM)



### 3.2 Register Addressing Mode

In Register addressing mode (R), the operand value is the content of a specified register or register pair (Refer to [Figure 3-1](#) for more information).

Working register addressing differs from Register addressing. In this, it uses a register pointer to specify an 8-byte working register space in the register file and an 8-bit register within that space (Refer to [Figure 3-2](#) for more information).

[Figure 3-1](#) illustrates the register addressing.

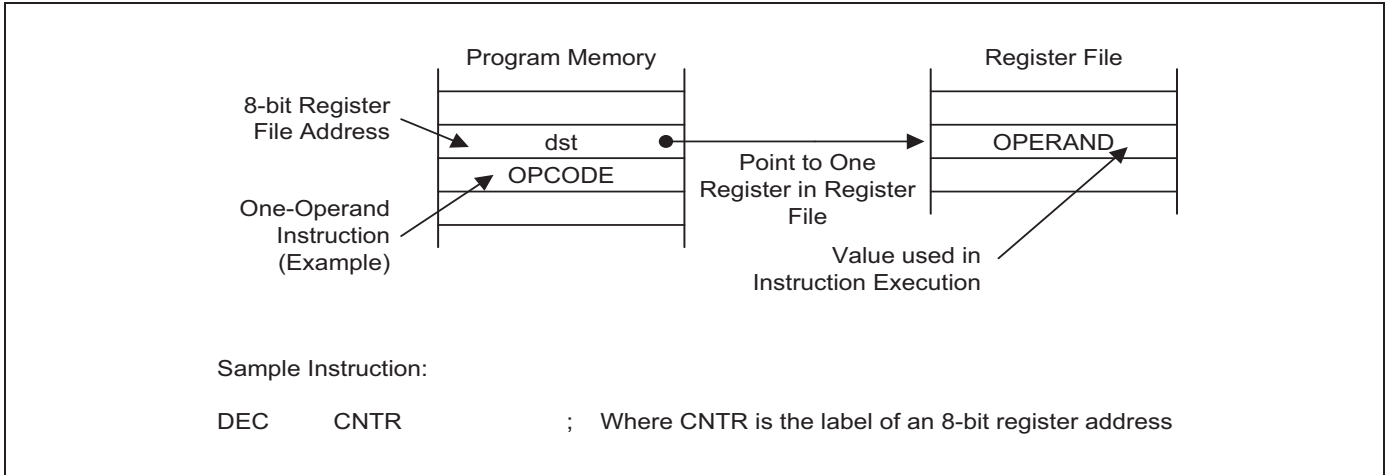


Figure 3-1 Register Addressing

[Figure 3-2](#) illustrates the working register addressing.

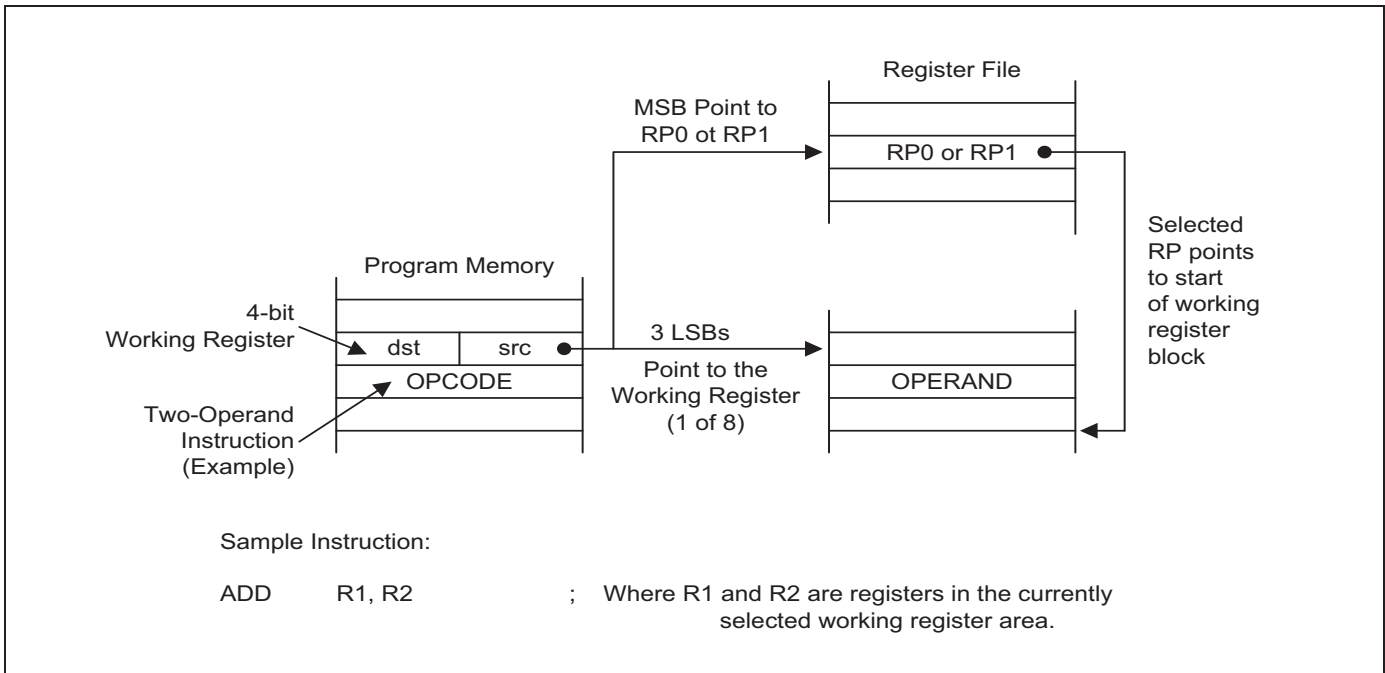


Figure 3-2 Working Register Addressing

### 3.3 Indirect Register Addressing Mode

In Indirect Register (IR) addressing mode, the content of the specified register or register pair is the address of the operand. Depending on the instruction used, the actual address may point to a register in the register file to program memory (ROM), or to an external memory space (Refer to [Figure 3-3](#) and [Figure 3-6](#) for more information).

You can use any 8-bit register to indirectly address another register. Any 16-bit register pair can be used to indirectly address another memory location. Please note, however, that you cannot access locations C0H–FFH in set 1 using the Indirect Register addressing mode.

[Figure 3-3](#) illustrates the indirect register addressing to register file.

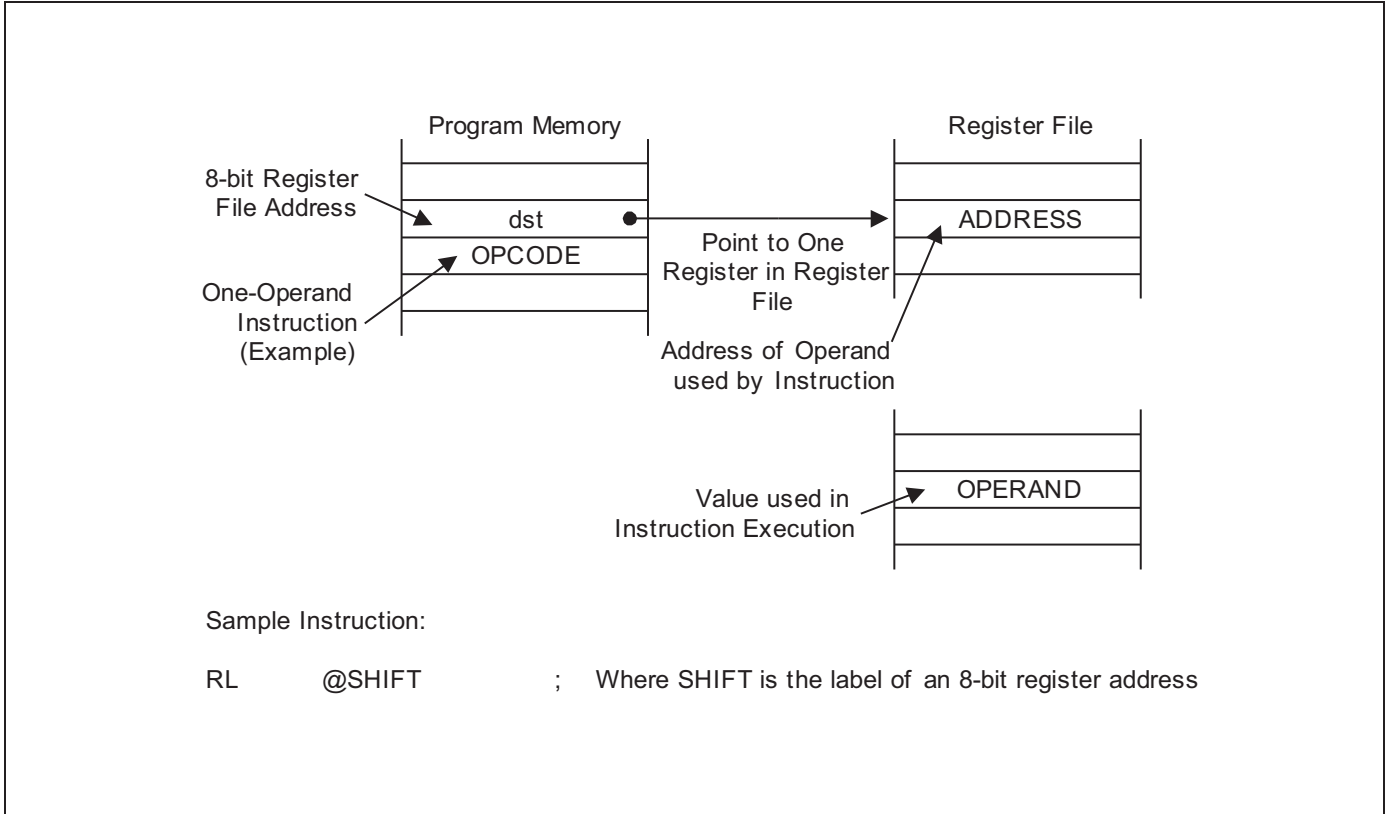


Figure 3-3 Indirect Register Addressing to Register File

Figure 3-4 illustrates the indirect register addressing to program memory.

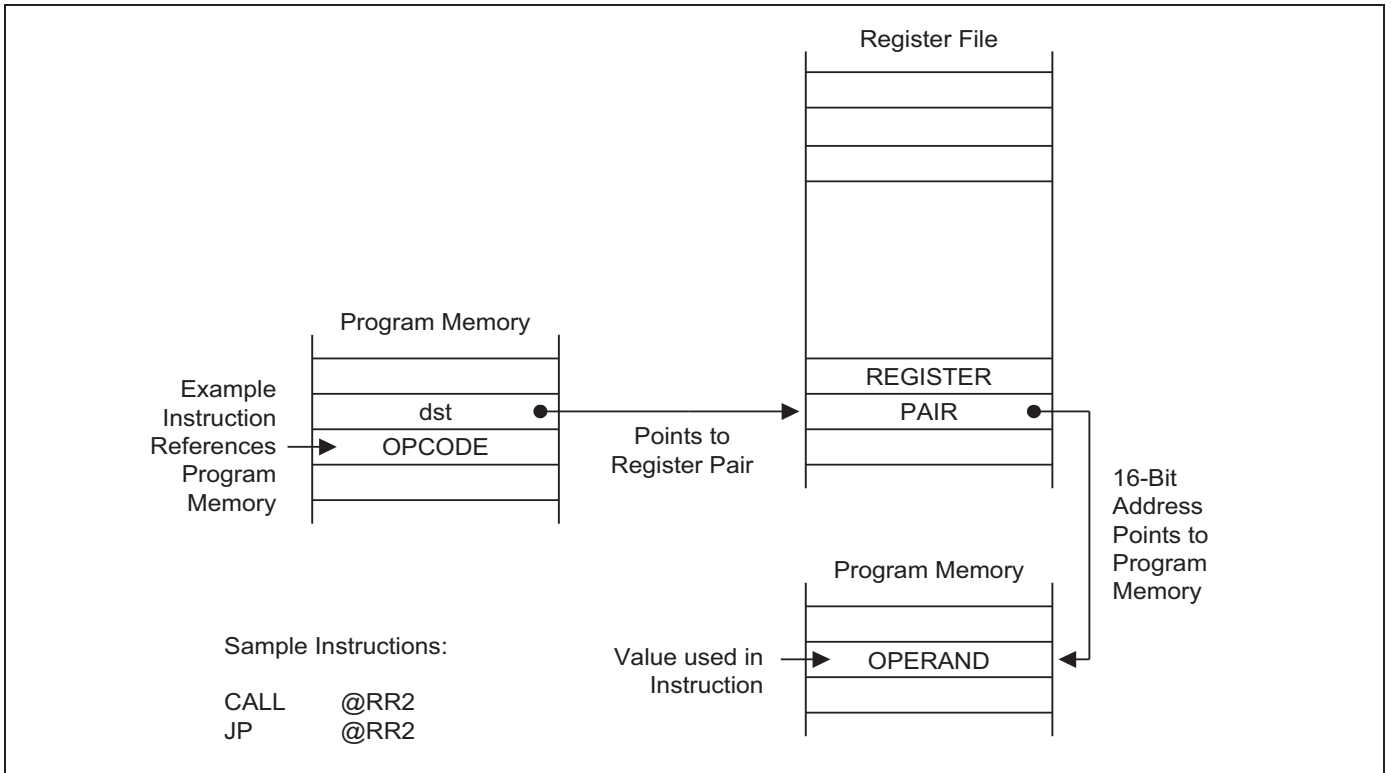


Figure 3-4 Indirect Register Addressing to Program Memory

Figure 3-5 illustrates the indirect working register addressing to register file.

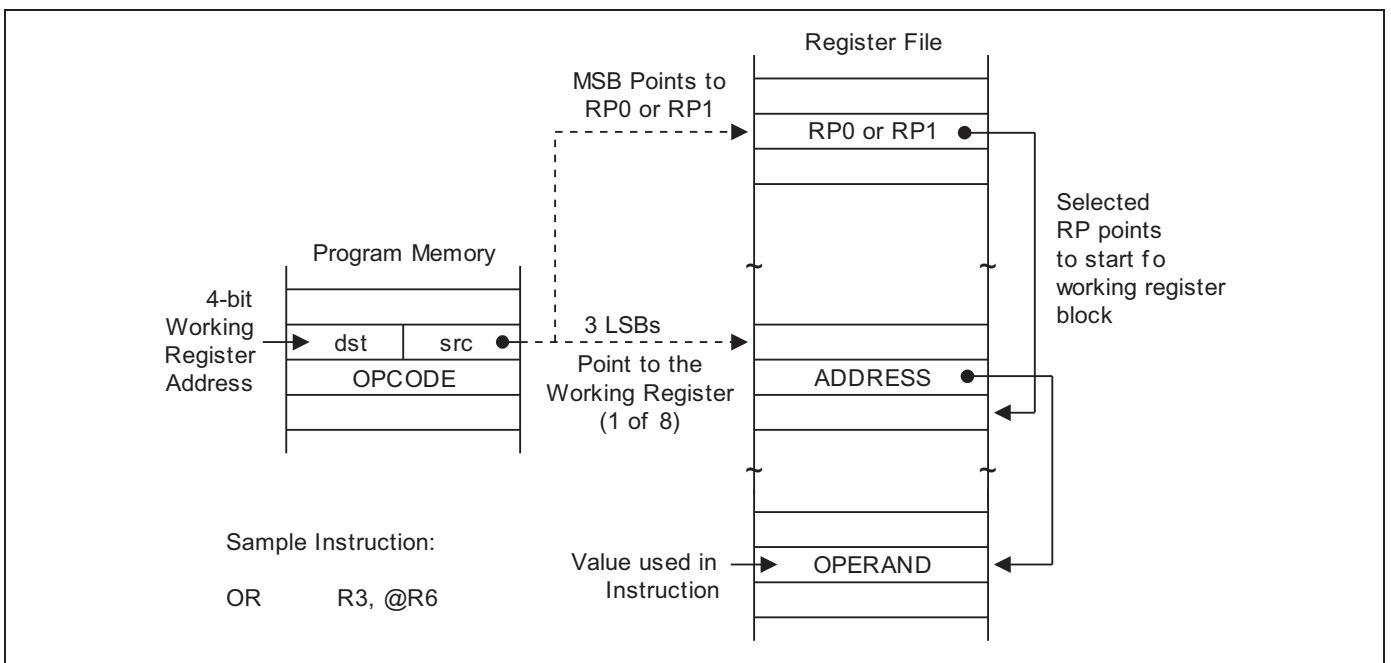


Figure 3-5 Indirect Working Register Addressing to Register File

Figure 3-6 illustrates the indirect working register addressing to program or data memory.

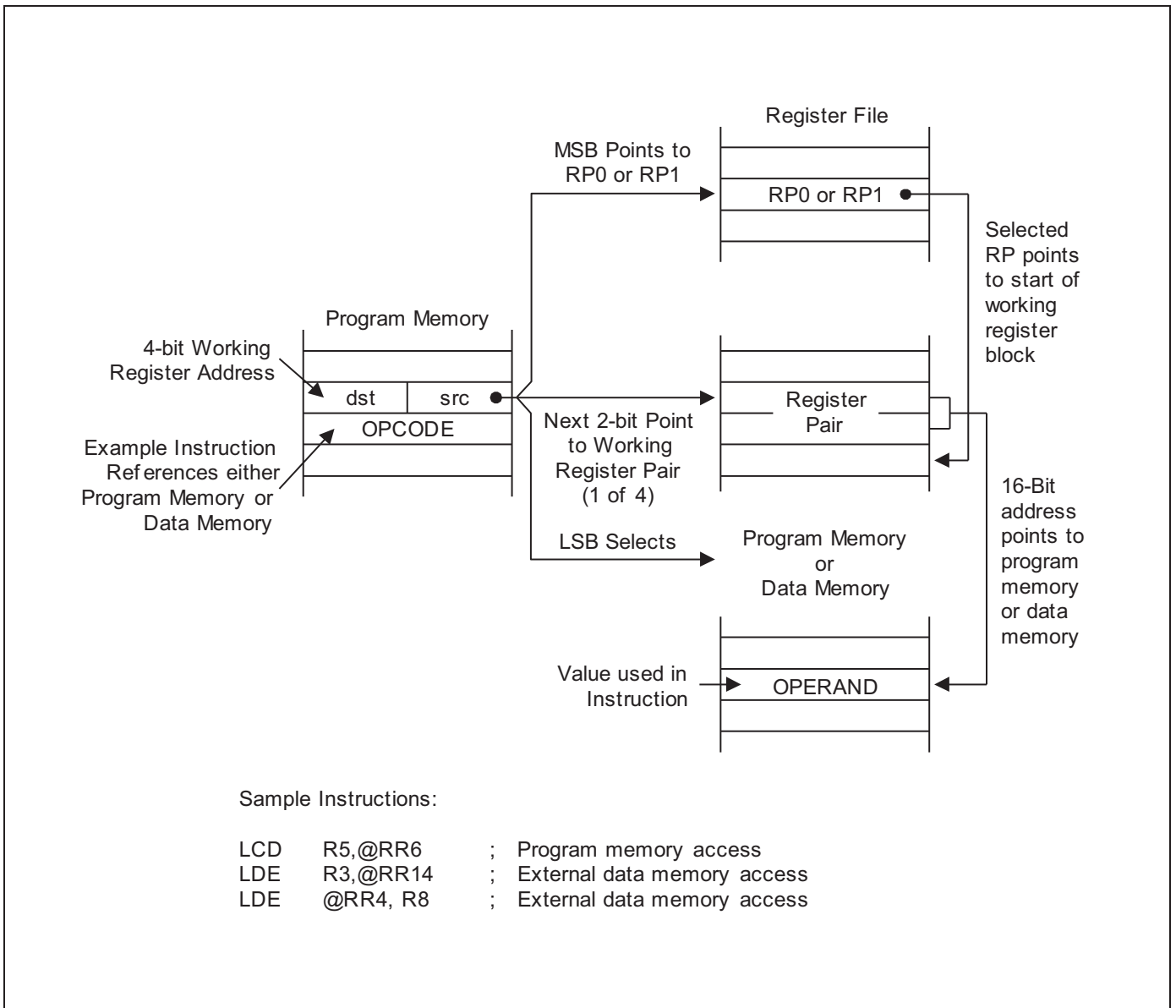


Figure 3-6 Indirect Working Register Addressing to Program or Data Memory

### 3.4 Indexed Addressing Mode

Indexed (X) addressing mode adds an offset value to a base address during instruction execution to calculate the effective operand address (Refer to [Figure 3-7](#) for more information). You can use Indexed addressing mode to access locations in the internal register file or in external memory. Please note, however, that you cannot access locations C0H–FFH in set 1 using Indexed addressing mode.

In short offset Indexed addressing mode, the 8-bit displacement is treated as a signed integer in the range – 128 to + 127. This applies to external memory accesses only (Refer to [Figure 3-8](#) for more information).

For register file addressing, the instruction that provides an 8-bit base address is added to an 8-bit offset contained in a working register. For external memory accesses, the base address is stored in the working register pair designated in the instruction. The 8-bit or 16-bit offset given in the instruction is then added to that base address (Refer to [Figure 3-9](#) for more information.).

The only instruction that supports Indexed addressing mode for the internal register file is the Load instruction (LD). The LDC and LDE instructions support Indexed addressing mode for internal program memory and external data memory, when implemented.

[Figure 3-7](#) illustrates the indexed addressing to register file.

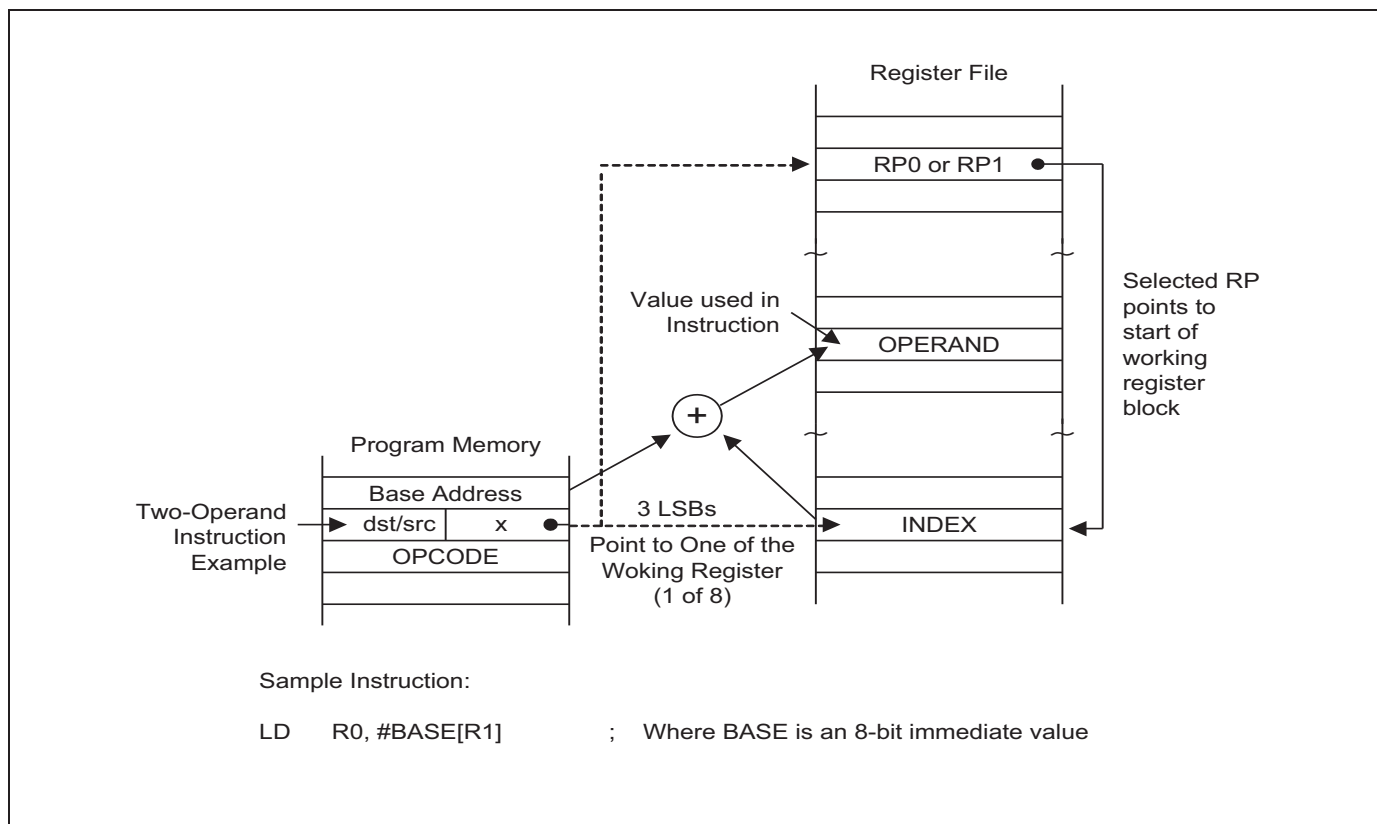


Figure 3-7 Indexed Addressing to Register File

Figure 3-8 illustrates the indexed addressing to program or data memory with short offset.

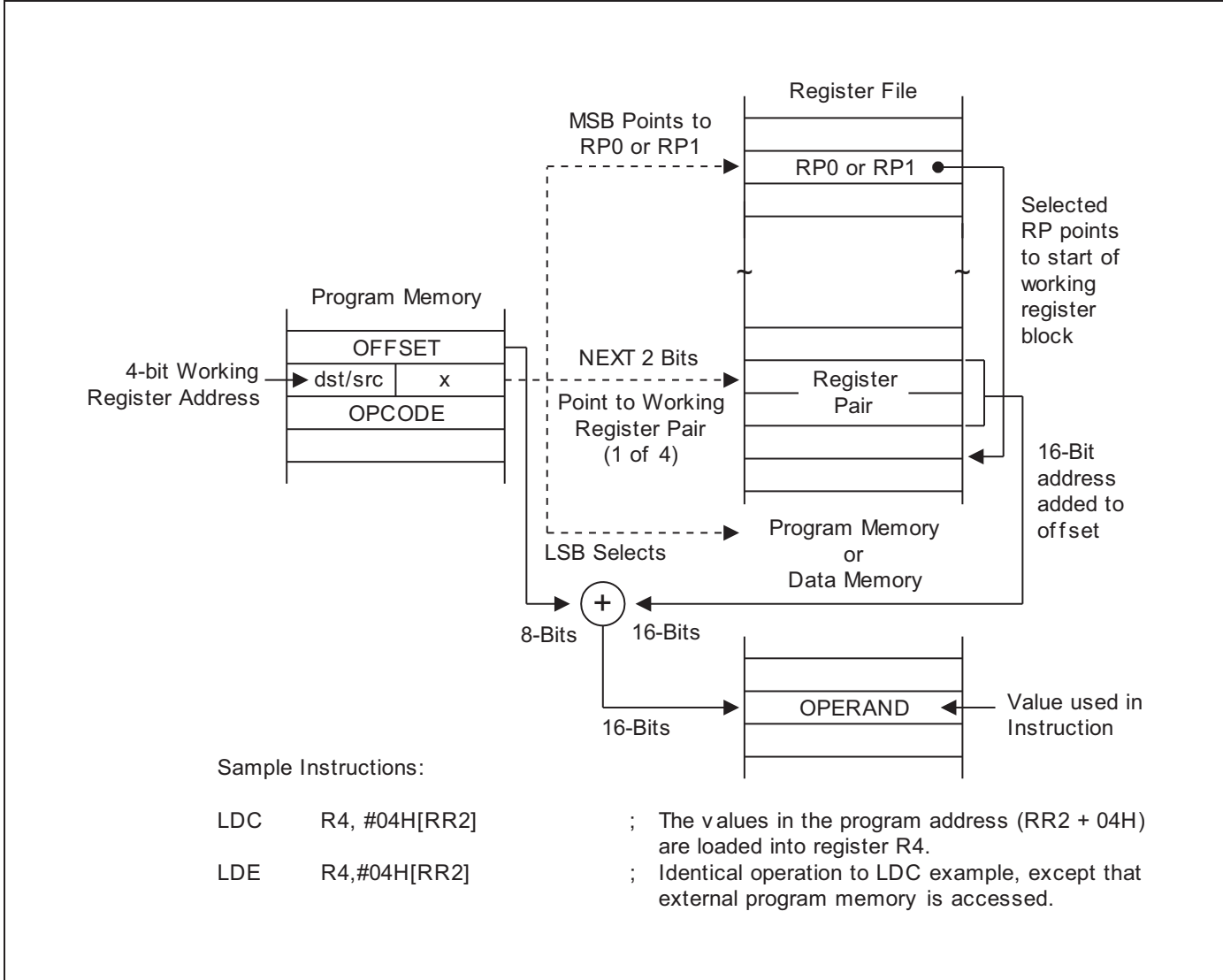


Figure 3-8 Indexed Addressing to Program or Data Memory with Short Offset

Figure 3-9 illustrates the indexed addressing to program or data memory.

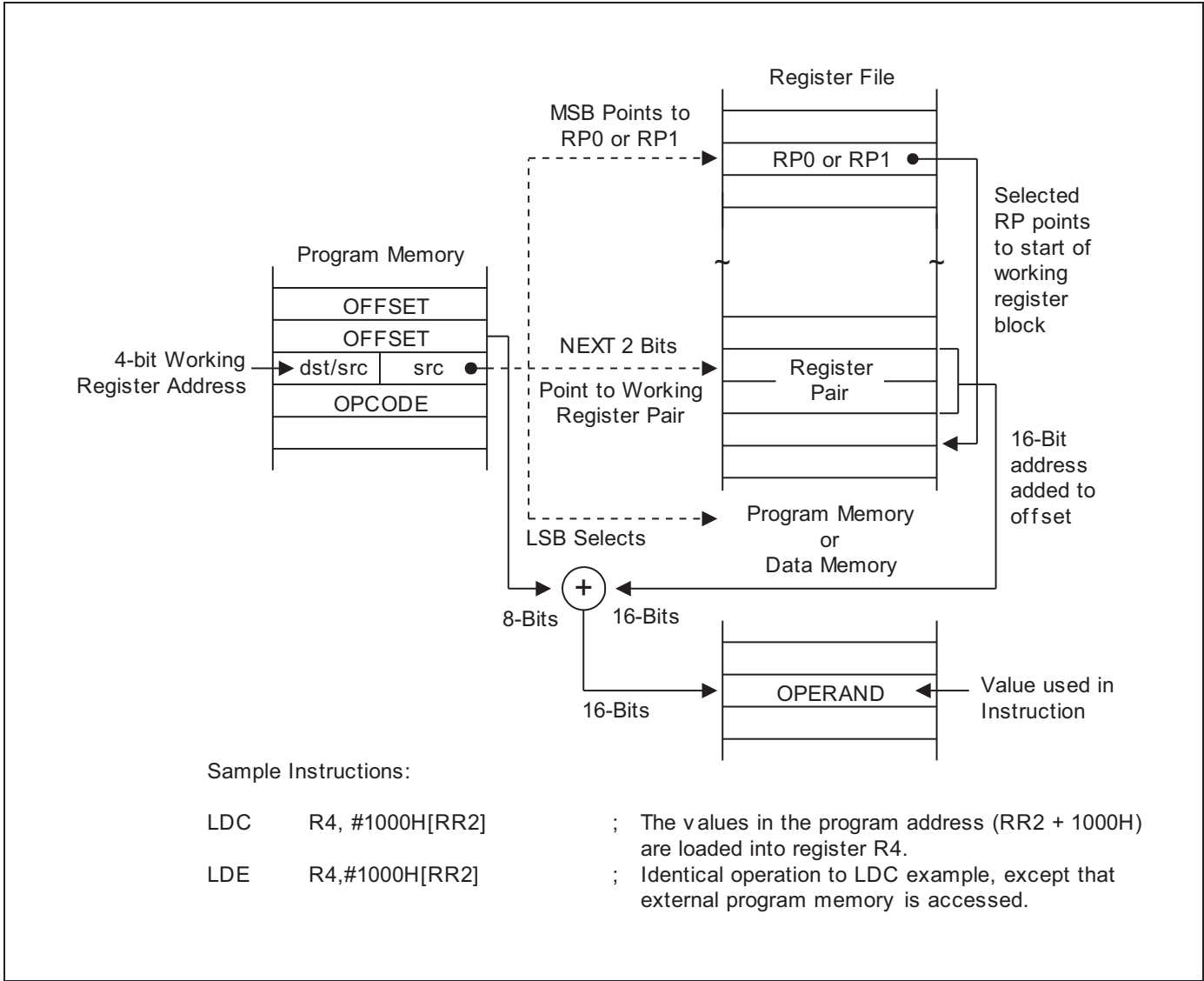


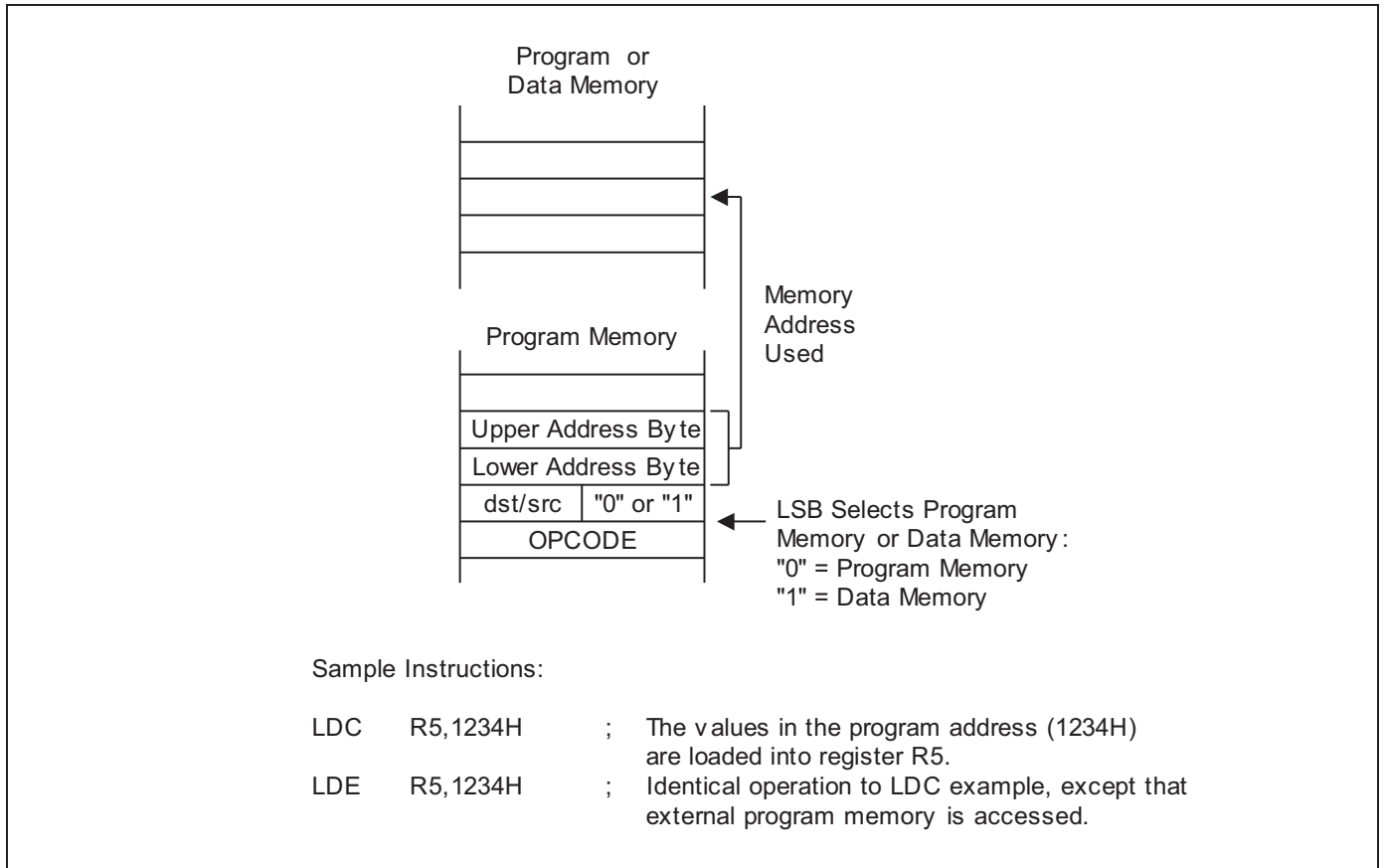
Figure 3-9 Indexed Addressing to Program or Data Memory

### 3.5 Direct Address Mode

In Direct Address (DA) mode, the instruction provides the operand's 16-bit memory address. Jump (JP) and Call (CALL) instructions use this addressing mode to specify the 16-bit destination address that is loaded into the PC whenever a JP or CALL instruction is executed.

The LDC and LDE instructions can use Direct Address mode to specify the source or destination address for Load operations to program memory (LDC) or to external data memory (LDE), if it implements them.

[Figure 3-10](#) illustrates the direct addressing for load instructions.



**Figure 3-10 Direct Addressing for Load Instructions**



Figure 3-11 illustrates the direct addressing for call and jump instructions.

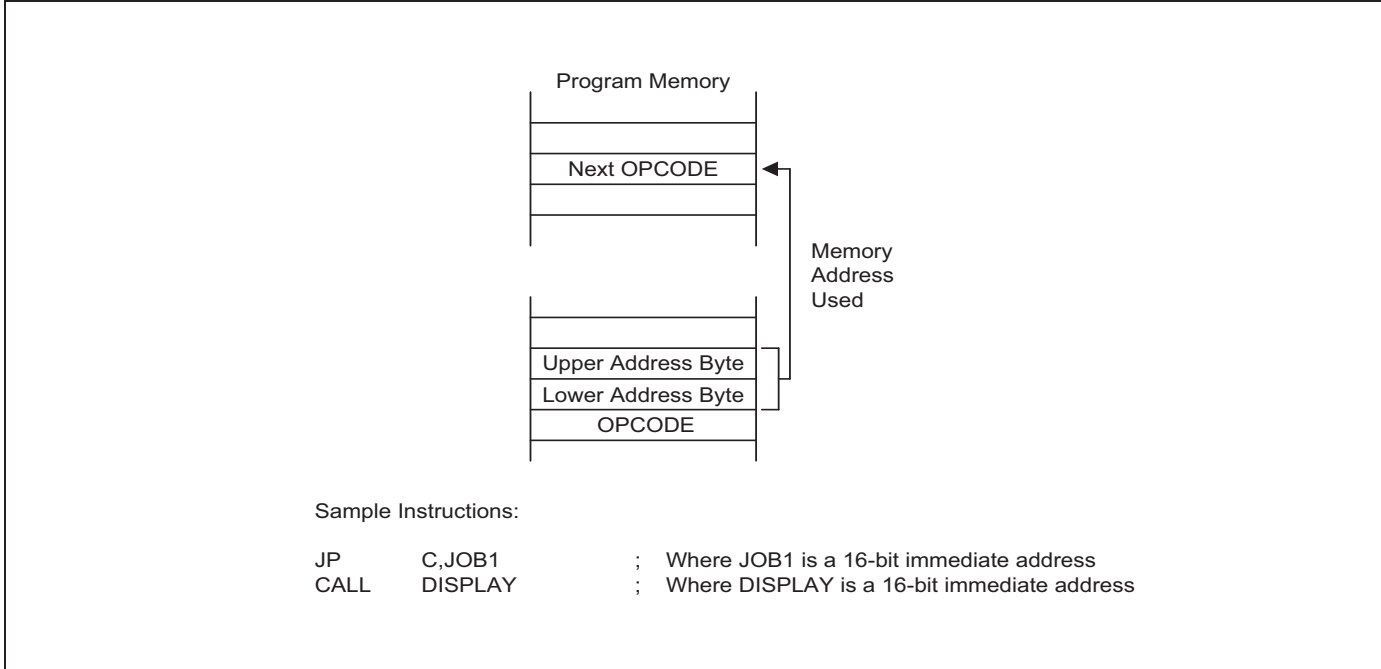


Figure 3-11 Direct Addressing for Call and Jump Instructions

### 3.6 Indirect Address Mode

In Indirect Address (IA) mode, the instruction specifies an address located in the lowest 256 bytes of the program memory. The selected pair of memory locations contains the actual address of the next instruction to be executed. Only the CALL instruction can use the Indirect Address mode.

As the Indirect Address mode assumes that the operand is located in the lowest 256 bytes of program memory. It supplies only 8-bit address in the instruction. It assumes that all the upper bytes of the destination are zeroes.

Figure 3-12 illustrates the indirect addressing.

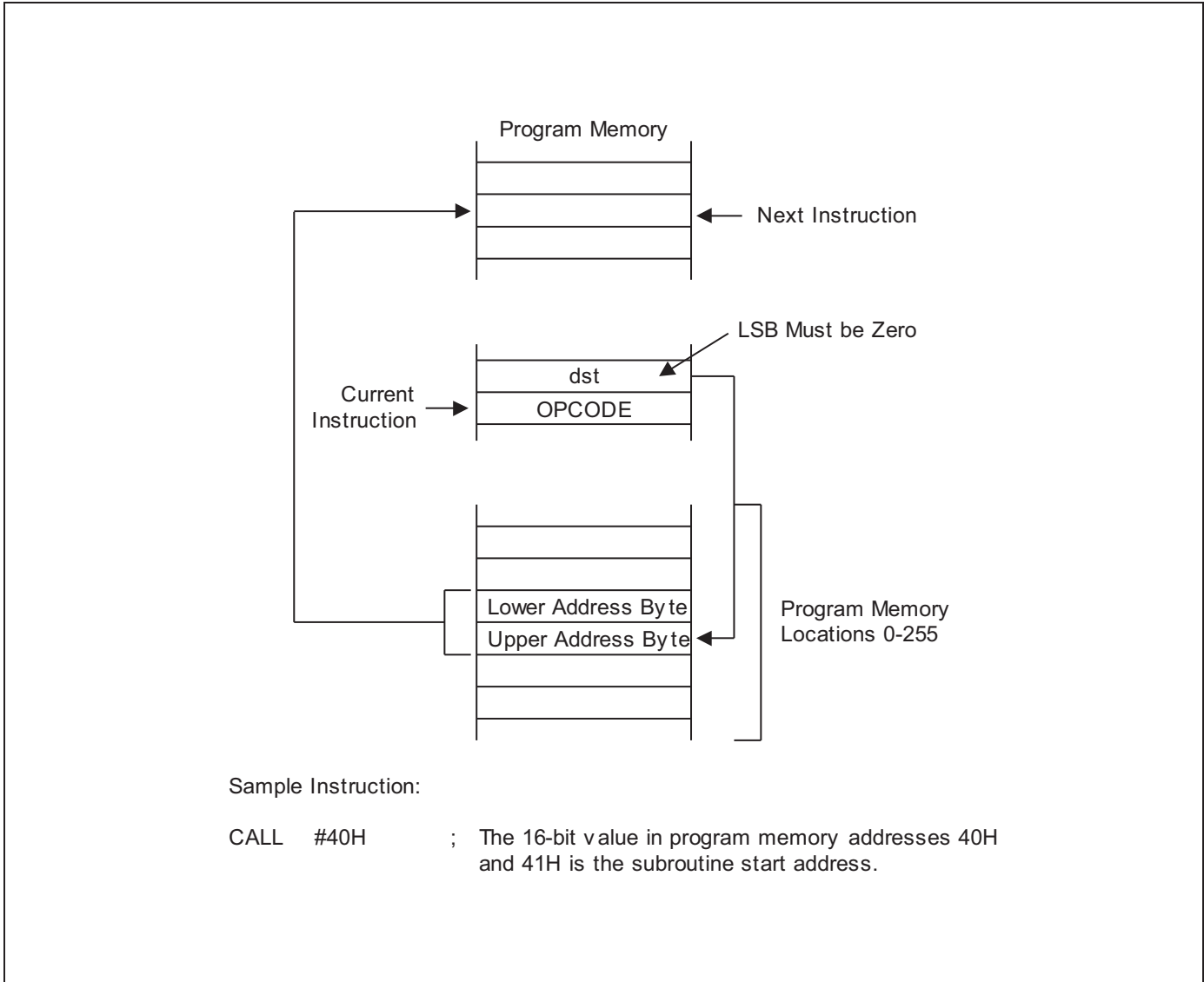


Figure 3-12 Indirect Addressing

### 3.7 Relative Address Mode

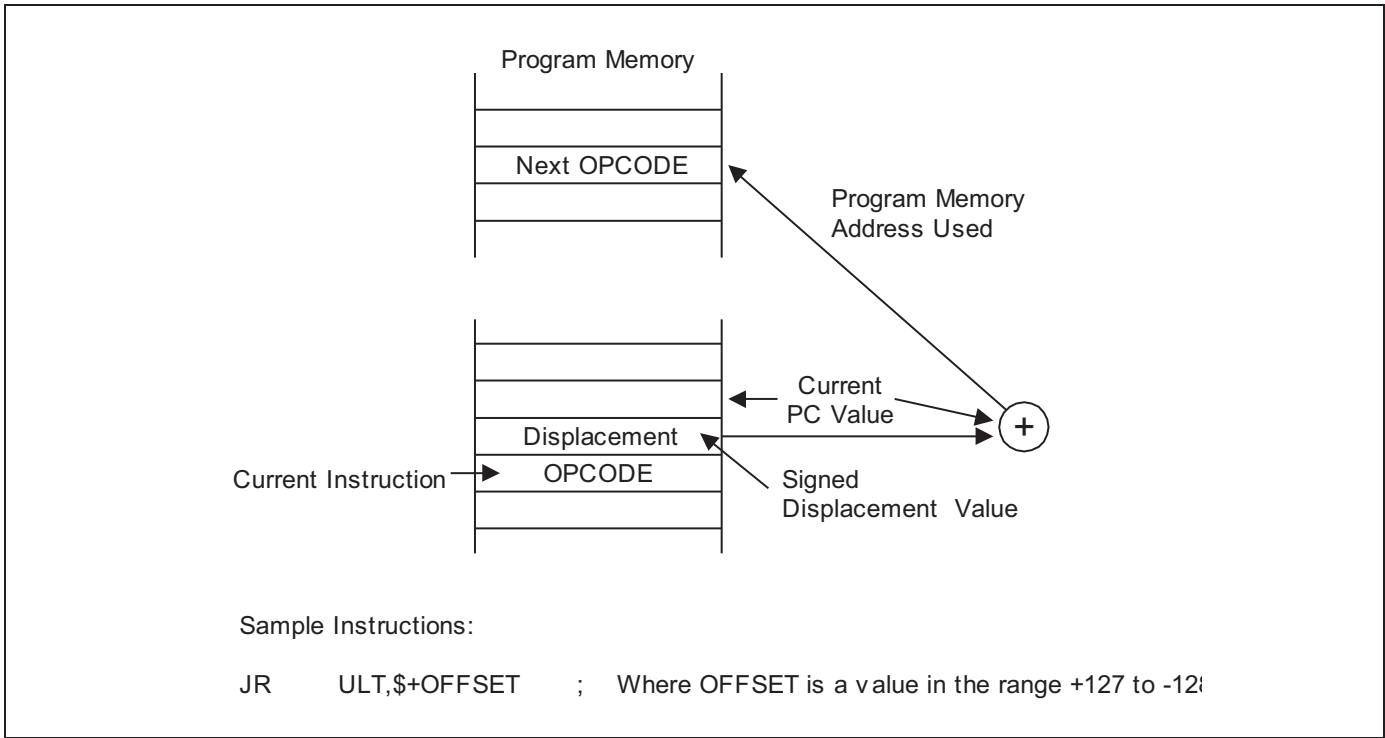
In Relative Address (RA) mode, a two-complement signed displacement between – 128 and + 127 is specified in the instruction. Then it adds the displacement value to the current PC value. The result is the address of the next instruction to execute. Before this addition occurs, the PC contains the address of the instruction immediately next to the current instruction.

Several program control instructions use the Relative Address mode to perform conditional jumps.

The instructions that support RA addressing are:

- BTJRF
- BTJRT
- DJNZ
- CPIJE
- CPIJNE
- JR

[Figure 3-13](#) illustrates the relative addressing.

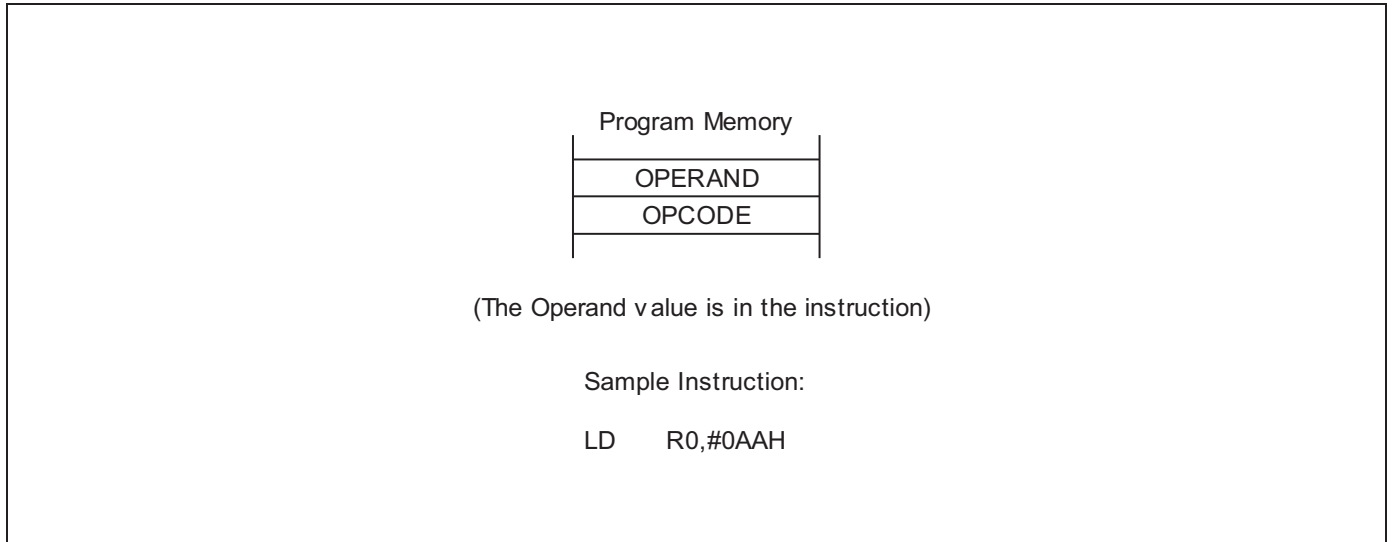


**Figure 3-13 Relative Addressing**

### 3.8 Immediate Mode

In Immediate (IM) addressing mode, the operand value used in the instruction is the value supplied in the operand field itself. The operand may be 1 byte or one word in length, depending on the instruction used. Immediate addressing mode is useful for loading constant values into registers.

[Figure 3-14](#) illustrates the immediate addressing.



**Figure 3-14 Immediate Addressing**

# 4 Control Registers

## 4.1 Overview

This chapter describes S3F8S19/F8S15 control registers in an easy-to-read format. The descriptions of S3F8S19/F8S15 control registers help you to get familiar with the mapped locations in the register file. You can also use them as a quick-reference source when writing application programs.

[Table 4-1](#), [Table 4-2](#), [Table 4-3](#) and [Table 4-4](#) describe system and peripheral registers. [Figure 4-1](#) illustrates the important features of the standard register description format.

Control register descriptions are alphabetically arranged according to register mnemonic. Part II of this manual provides more information about control registers descriptions.

Table 4-1 describes the system and peripheral control registers set 1.

**Table 4-1 System and Peripheral Control Registers Set 1**

| Register Name                           | Mnemonic | Address |     | R/W | nRESET Value (bit) |   |   |   |   |   |   |   |   |
|---|----------|---------|-----|-----|--------------------|---|---|---|---|---|---|---|---|
|   |          | Decimal | Hex |     | 7                  | 6 | 5 | 4 | 3 | 2 | 1 | 0 |   |
| A/D Converter Data register (high byte) | ADDATAH  | 208     | D0H | R   | x                  | x | x | x | x | x | x | x | x |
| A/D Converter Data register (low byte)  | ADDATAL  | 209     | D1H | R   | –                  | – | – | – | – | – | – | x | x |
| A/D Converter Control register          | ADCON    | 210     | D2H | R/W | 0                  | 0 | 0 | 0 | 0 | 0 | 0 | 0 | 0 |
| Basic Timer Control register            | BTCON    | 211     | D3H | R/W | 0                  | 0 | 0 | 0 | 0 | 0 | 0 | 0 | 0 |
| System Clock Control register           | CLKCON   | 212     | D4H | R/W | 0                  | – | – | 0 | 0 | – | – | – | – |
| System Flags register                   | FLAGS    | 213     | D5H | R/W | x                  | x | x | x | x | x | 0 | 0 | 0 |
| Register pointer 0                      | RP0      | 214     | D6H | R/W | 1                  | 1 | 0 | 0 | 0 | – | – | – | – |
| Register pointer 1                      | RP1      | 215     | D7H | R/W | 1                  | 1 | 0 | 0 | 1 | – | – | – | – |
| Stack pointer (high byte)               | SPH      | 216     | D8H | R/W | x                  | x | x | x | x | x | x | x | x |
| Stack pointer (low byte)                | SPL      | 217     | D9H | R/W | x                  | x | x | x | x | x | x | x | x |
| Instruction pointer (high byte)         | IPH      | 218     | DAH | R/W | x                  | x | x | x | x | x | x | x | x |
| Instruction pointer (low byte)          | IPL      | 219     | DBH | R/W | x                  | x | x | x | x | x | x | x | x |
| Interrupt Request register              | IRQ      | 220     | DCH | R   | 0                  | 0 | 0 | 0 | 0 | 0 | 0 | 0 | 0 |
| Interrupt Mask register                 | IMR      | 221     | DDH | R/W | x                  | x | x | x | x | x | x | x | x |
| System Mode register                    | SYM      | 222     | DEH | R/W | –                  | – | – | x | x | x | 0 | 0 | 0 |
| Register Page pointer                   | PP       | 223     | DFH | R/W | 0                  | 0 | 0 | 0 | 0 | 0 | 0 | 0 | 0 |

**NOTE:**

1. An "x" means that the bit value is undefined following reset.
2. Dash ("-") refers to the bit that is neither used nor mapped. However, it reads this bit as "0".

Table 4-2 describes the system and peripheral control registers set 1 bank 0.

**Table 4-2 System and Peripheral Control Registers Set 1 Bank 0**

| Register Name                             | Mnemonic | Address |     | R/W | nRESET Value (bit) |   |   |   |   |   |   |   |   |
|---|----------|---------|-----|-----|--------------------|---|---|---|---|---|---|---|---|
|   |          | Decimal | Hex |     | 7                  | 6 | 5 | 4 | 3 | 2 | 1 | 0 |   |
| Timer A Counter register                  | TACNT    | 224     | E0H | R   | 0                  | 0 | 0 | 0 | 0 | 0 | 0 | 0 | 0 |
| Timer A Data register                     | TADATA   | 225     | E1H | R/W | 1                  | 1 | 1 | 1 | 1 | 1 | 1 | 1 | 1 |
| Timer A Control register                  | TACON    | 226     | E2H | R/W | 0                  | 0 | 0 | 0 | 0 | 0 | 0 | 0 | 0 |
| Timer A pre-scalar                        | TAPS     | 227     | E3H | R/W | 0                  | – | – | – | 0 | 0 | 0 | 0 | 0 |
| <b>Location E4H to E7H is Not Mapped.</b> |          |         |     |     |                    |   |   |   |   |   |   |   |   |
| Timer 0 Counter register (high byte)      | T0CNTH   | 232     | E8H | R   | 0                  | 0 | 0 | 0 | 0 | 0 | 0 | 0 | 0 |
| Timer 0 Counter register (Low Byte)       | T0CNTL   | 233     | E9H | R   | 0                  | 0 | 0 | 0 | 0 | 0 | 0 | 0 | 0 |
| Timer 0 Data register (high byte)         | T0DATAH  | 234     | EAH | R/W | 1                  | 1 | 1 | 1 | 1 | 1 | 1 | 1 | 1 |
| Timer 0 Data Register (low byte)          | T0DATAL  | 235     | EBH | R/W | 1                  | 1 | 1 | 1 | 1 | 1 | 1 | 1 | 1 |
| Timer 0 control register                  | T0CON    | 236     | ECH | R/W | 0                  | 0 | 0 | 0 | 0 | 0 | 0 | 0 | 0 |
| Timer 0 pre-scalar                        | T0PS     | 237     | EDH | R/W | –                  | – | – | – | 0 | 0 | 0 | 0 | 0 |
| Timer 1 Counter register (high byte)      | T1CNTH   | 238     | EEH | R   | 0                  | 0 | 0 | 0 | 0 | 0 | 0 | 0 | 0 |
| Timer 1 Counter register (low byte)       | T1CNTL   | 239     | EFH | R   | 0                  | 0 | 0 | 0 | 0 | 0 | 0 | 0 | 0 |
| Timer 1 Data register (High byte)         | T1DATAH  | 240     | F0H | R/W | 1                  | 1 | 1 | 1 | 1 | 1 | 1 | 1 | 1 |
| Timer 1 Data register (low byte)          | T1DATAL  | 241     | F1H | R/W | 1                  | 1 | 1 | 1 | 1 | 1 | 1 | 1 | 1 |
| Timer 1 Control register                  | T1CON    | 242     | F2H | R/W | 0                  | 0 | 0 | 0 | 0 | 0 | 0 | 0 | 0 |
| Timer 1 pre-scalar                        | T1PS     | 243     | F3H | R/W | 0                  | – | – | – | 0 | 0 | 0 | 0 | 0 |
| Timer 2 Counter register (high byte)      | T2CNTH   | 244     | F4H | R   | 0                  | 0 | 0 | 0 | 0 | 0 | 0 | 0 | 0 |
| Timer 2 Counter register (low byte)       | T2CNTL   | 245     | F5H | R   | 0                  | 0 | 0 | 0 | 0 | 0 | 0 | 0 | 0 |
| Timer 2 Data register (High Byte)         | T2DATAH  | 246     | F6H | R/W | 1                  | 1 | 1 | 1 | 1 | 1 | 1 | 1 | 1 |
| Timer 2 Data register (Low Byte)          | T2DATAL  | 247     | F7H | R/W | 1                  | 1 | 1 | 1 | 1 | 1 | 1 | 1 | 1 |
| Timer 2 Control register                  | T2CON    | 248     | F8H | R/W | 0                  | 0 | 0 | 0 | 0 | 0 | 0 | 0 | 0 |
| Timer 2 pre-scalar                        | T2PS     | 249     | F9H | R/W | 0                  | – | – | – | 0 | 0 | 0 | 0 | 0 |
| Watch Timer Control register              | WTCON    | 250     | FAH | R/W | 0                  | 0 | 0 | 0 | 0 | 0 | 0 | 0 | 0 |
| Oscillator Control register               | OSCCON   | 251     | FBH | R/W | –                  | – | – | – | 0 | 0 | – | 0 | 0 |
| <b>Location FCH is Not Mapped</b>         |          |         |     |     |                    |   |   |   |   |   |   |   |   |
| Basic Timer counter                       | BTCNT    | 253     | FDH | R   | 0                  | 0 | 0 | 0 | 0 | 0 | 0 | 0 | 0 |
| <b>Location FEH is Not Mapped</b>         |          |         |     |     |                    |   |   |   |   |   |   |   |   |
| Interrupt Priority register               | IPR      | 255     | FFH | R/W | x                  | x | x | x | x | x | x | x | x |

Table 4-3 describes the system and peripheral control registers set 1 bank 1.

**Table 4-3 System and Peripheral Control Registers Set 1 Bank 1**

| Register Name                             | Mnemonic | Address |     | R/W | nRESET Value (bit)          |   |   |   |   |   |   |   |   |
|---|----------|---------|-----|-----|-----------------------------|---|---|---|---|---|---|---|---|
|   |          | Decimal | Hex |     | 7                           | 6 | 5 | 4 | 3 | 2 | 1 | 0 |   |
| Port 0 Control register (High Byte)       | P0CONH   | 224     | E0H | R/W | 0                           | 0 | 0 | 0 | 0 | 0 | 0 | 0 | 0 |
| Port 0 Control register (Low Byte)        | P0CONL   | 225     | E1H | R/W | 0                           | 0 | 0 | 0 | 0 | 0 | 0 | 0 | 0 |
| Port 0 Pull-up Resistor Enable register   | P0PUR    | 226     | E2H | R/W | 0                           | 0 | 0 | 0 | 0 | 0 | 0 | 0 | 0 |
| Port 0 Interrupt Control register         | P0INT    | 227     | E3H | R/W | 0                           | 0 | 0 | 0 | 0 | 0 | 0 | 0 | 0 |
| Port 1 Control Register (high byte)       | P1CONH   | 228     | E4H | R/W | 0                           | 0 | 0 | 0 | 0 | 0 | 0 | 0 | 0 |
| Port 1 Control register (Low byte)        | P1CONL   | 229     | E5H | R/W | 0                           | 0 | 0 | 0 | 0 | 0 | 0 | 0 | 0 |
| Port 2 Control register (high byte)       | P2CONH   | 230     | E6H | R/W | 0                           | 0 | 0 | 0 | 0 | 0 | 0 | 0 | 0 |
| Port 2 Control register (low byte)        | P2CONL   | 231     | E7H | R/W | 0                           | 0 | 0 | 0 | 0 | 0 | 0 | 0 | 0 |
| Port 3 Control register (high byte)       | P3CONH   | 232     | E8H | R/W | 0                           | 0 | 0 | 0 | 0 | 0 | 0 | 0 | 0 |
| Port 3 Control register (low byte)        | P3CONL   | 233     | E9H | R/W | 0                           | 0 | 0 | 0 | 0 | 0 | 0 | 0 | 0 |
| Port 3 N-channel Open-drain Mode register | PNE3     | 234     | EAH | R/W | 0                           | 0 | 0 | 0 | 0 | 0 | 0 | 0 | 0 |
| Port 3 Interrupt control register         | P3INT    | 235     | EBH | R/W | 0                           | 0 | 0 | 0 | 0 | 0 | 0 | 0 | 0 |
| Port 3 Pull-up Resistor Enable register   | P3PUR    | 236     | ECH | R/W | 0                           | 0 | 0 | 0 | 0 | 0 | 0 | 0 | 0 |
| Port 4 Pull-up Resistor Enable register   | P4PUR    | 237     | EDH | R/W | 0                           | 0 | 0 | 0 | 0 | 0 | 0 | 0 | 0 |
| Port 4 Control register (high Byte)       | P4CONH   | 238     | EEH | R/W | 0                           | 0 | 0 | 0 | 0 | 0 | 0 | 0 | 0 |
| Port 4 Control register (low byte)        | P4CONL   | 239     | EFH | R/W | 0                           | 0 | 0 | 0 | 0 | 0 | 0 | 0 | 0 |
| Port 4 N-channel Open-drain Mode register | PNE4     | 240     | F0H | R/W | 0                           | 0 | 0 | 0 | 0 | 0 | 0 | 0 | 0 |
| Port 0 Data register                      | P0       | 241     | F1H | R/W | 0                           | 0 | 0 | 0 | 0 | 0 | 0 | 0 | 0 |
| Port 1 Data register                      | P1       | 242     | F2H | R/W | 0                           | 0 | 0 | 0 | 0 | 0 | 0 | 0 | 0 |
| Port 2 Data register                      | P2       | 243     | F3H | R/W | 0                           | 0 | 0 | 0 | 0 | 0 | 0 | 0 | 0 |
| Port 3 Data register                      | P3       | 244     | F4H | R/W | 0                           | 0 | 0 | 0 | 0 | 0 | 0 | 0 | 0 |
| Port 4 Data register                      | P4       | 245     | F5H | R/W | 0                           | 0 | 0 | 0 | 0 | 0 | 0 | 0 | 0 |
| External Interrupt Pending register       | PINTPND  | 246     | F6H | R/W | 0                           | 0 | 0 | 0 | 0 | 0 | 0 | 0 | 0 |
| SPI Control register                      | SPICON   | 247     | F7H | R/W | 0                           | 0 | 0 | 0 | 0 | 0 | 0 | 0 | 0 |
| SPI Status register                       | SPISTAT  | 248     | F8H | R/W | 0                           | 0 | 0 | – | – | – | – | 0 | 0 |
| SPI Data register                         | SPIDATA  | 249     | F9H | R/W | 1                           | 1 | 1 | 1 | 1 | 1 | 1 | 1 | 1 |
| Reset ID                                  | RESETID  | 250     | FAH | R/W | Refer to detail description |   |   |   |   |   |   |   |   |
| STOP Control register                     | STPCON   | 251     | FBH | R/W | 0                           | 0 | 0 | 0 | 0 | 0 | 0 | 0 | 0 |
| LCD Mode register                         | LMOD     | 252     | FCH | R/W | –                           | – | – | – | – | 0 | 0 | 0 | 0 |



| Register Name             | Mnemonic | Address |     | R/W | nRESET Value (bit) |   |   |   |   |   |   |   |   |
|---------------------------|----------|---------|-----|-----|--------------------|---|---|---|---|---|---|---|---|
|                           |          | Decimal | Hex |     | 7                  | 6 | 5 | 4 | 3 | 2 | 1 | 0 |   |
| LCD Control register      | LCON     | 253     | FDH | R/W | 0                  | 0 | 0 | 0 | 0 | 0 | 0 | 0 | 0 |
| LVD Control register      | LVDCON   | 254     | FEH | R/W | 1                  | – | 0 | 0 | 0 | – | 0 | 0 | 0 |
| Ring OSC Control register | ROSCCON  | 255     | FFH | R/W | 0                  | 0 | 0 | 0 | 0 | 0 | 0 | 0 | 0 |

[Table 4-4](#) describes the system and peripheral control registers page 8.

**Table 4-4 System and Peripheral Control Registers Page 8**

| Register Name                                    | Mnemonic   | Address |     | R/W | nRESET Value (bit) |                 |   |   |   |   |   |   |   |
|--|------------|---------|-----|-----|--------------------|-----------------|---|---|---|---|---|---|---|
|  |            | Decimal | Hex |     | 7                  | 6               | 5 | 4 | 3 | 2 | 1 | 0 |   |
| UART0 Control register (high byte)               | UART0CONH  | 0       | 00H | R/W | 0                  | 0               | 0 | 0 | 0 | 0 | 0 | 0 | 0 |
| UART0 Control register (low byte)                | UART0CONL  | 1       | 01H | R/W | 0                  | 0               | 0 | 0 | 0 | 0 | 0 | 0 | 0 |
| UART0 Data register                              | UDATA0     | 2       | 02H | R/W | x                  | x               | x | x | x | x | x | x | x |
| UART0 Baud Rate Data register                    | BRDATA0    | 3       | 03H | R/W | 1                  | 1               | 1 | 1 | 1 | 1 | 1 | 1 | 1 |
| UART1 Control register (high byte)               | UART1CONH  | 4       | 04H | R/W | 0                  | 0               | 0 | 0 | 0 | 0 | 0 | 0 | 0 |
| UART1 Control register (low byte)                | UART1CONL  | 5       | 05H | R/W | 0                  | 0               | 0 | 0 | 0 | 0 | 0 | 0 | 0 |
| UART1 Data register                              | UDATA1     | 6       | 06H | R/W | x                  | x               | x | x | x | x | x | x | x |
| UART1 Baud Rate data register                    | BRDATA1    | 7       | 07H | R/W | 1                  | 1               | 1 | 1 | 1 | 1 | 1 | 1 | 1 |
| Flash Memory Sector address register (High Byte) | FMSECH     | 8       | 08H | R/W | 0                  | 0               | 0 | 0 | 0 | 0 | 0 | 0 | 0 |
| Flash Memory Sector Address register (low byte)  | FMSECL     | 9       | 09H | R/W | 0                  | 0               | 0 | 0 | 0 | 0 | 0 | 0 | 0 |
| Flash Memory User Programming Enable register    | FMUSR      | 10      | 0AH | R/W | 0                  | 0               | 0 | 0 | 0 | 0 | 0 | 0 | 0 |
| Flash Memory Control register                    | FMCON      | 11      | 0BH | R/W | 0                  | 0               | 0 | 0 | 0 | – | – | 0 | 0 |
| IIC Control register                             | ICCR       | 12      | 0CH | R/W | 0                  | 0               | 0 | 0 | 1 | 1 | 1 | 1 | 1 |
| IIC Status register                              | ICSR       | 13      | 0DH | R/W | 0                  | 0               | 0 | 0 | 0 | 0 | 0 | 0 | 0 |
| IIC Data Shift register                          | IDSR       | 14      | 0EH | R/W | x                  | x               | x | x | x | x | x | x | x |
| IIC Address register                             | IAR        | 15      | 0FH | R/W | x                  | x               | x | x | x | x | x | x | x |
| Stop Wake-up Timer Control register              | SWTCON     | 16      | 10H | R/W | 0                  | –               | 0 | – | 0 | 0 | 0 | 0 | 0 |
| 16-bit Timer B Control register                  | TBCON      | 17      | 11H | R/W | 0                  | 0               | 0 | 0 | 0 | 0 | 0 | 0 | 0 |
| Timer B Reference Data register 0 (high byte)    | TBDATA0H   | 18      | 12H | R/W | 1                  | 1               | 1 | 1 | 1 | 1 | 1 | 1 | 1 |
| Timer B Reference Data register 0 (low byte)     | TBDATA0L   | 19      | 13H | R/W | 1                  | 1               | 1 | 1 | 1 | 1 | 1 | 1 | 1 |
| Timer B Reference Data register 1 (high byte)    | TBDATA1H   | 20      | 14H | R/W | 1                  | 1               | 1 | 1 | 1 | 1 | 1 | 1 | 1 |
| Timer B Reference Data register 1 (low byte)     | TBDATA1L   | 21      | 15H | R/W | 1                  | 1               | 1 | 1 | 1 | 1 | 1 | 1 | 1 |
| Timer B Trigger Control register                 | TBTRG      | 22      | 16H | R/W | 0                  | 0               | 0 | 0 | 0 | 0 | 0 | 0 | 0 |
| Internal OSC Calibration Data register           | OSCCALDATA | 23      | 17H | R/W | –                  | Refer to (NOTE) |   |   |   |   |   |   |   |
| Internal OSC Calibration Control register        | OSCCALCON  | 24      | 18H | R/W | 0                  | 0               | 0 | 0 | 0 | 0 | 0 | 0 | 0 |

**NOTE:** The reset value of OSCCALDATA register is factory-calibrated. Different chips may have different reset values.

Figure 4-1 illustrates the register description format.

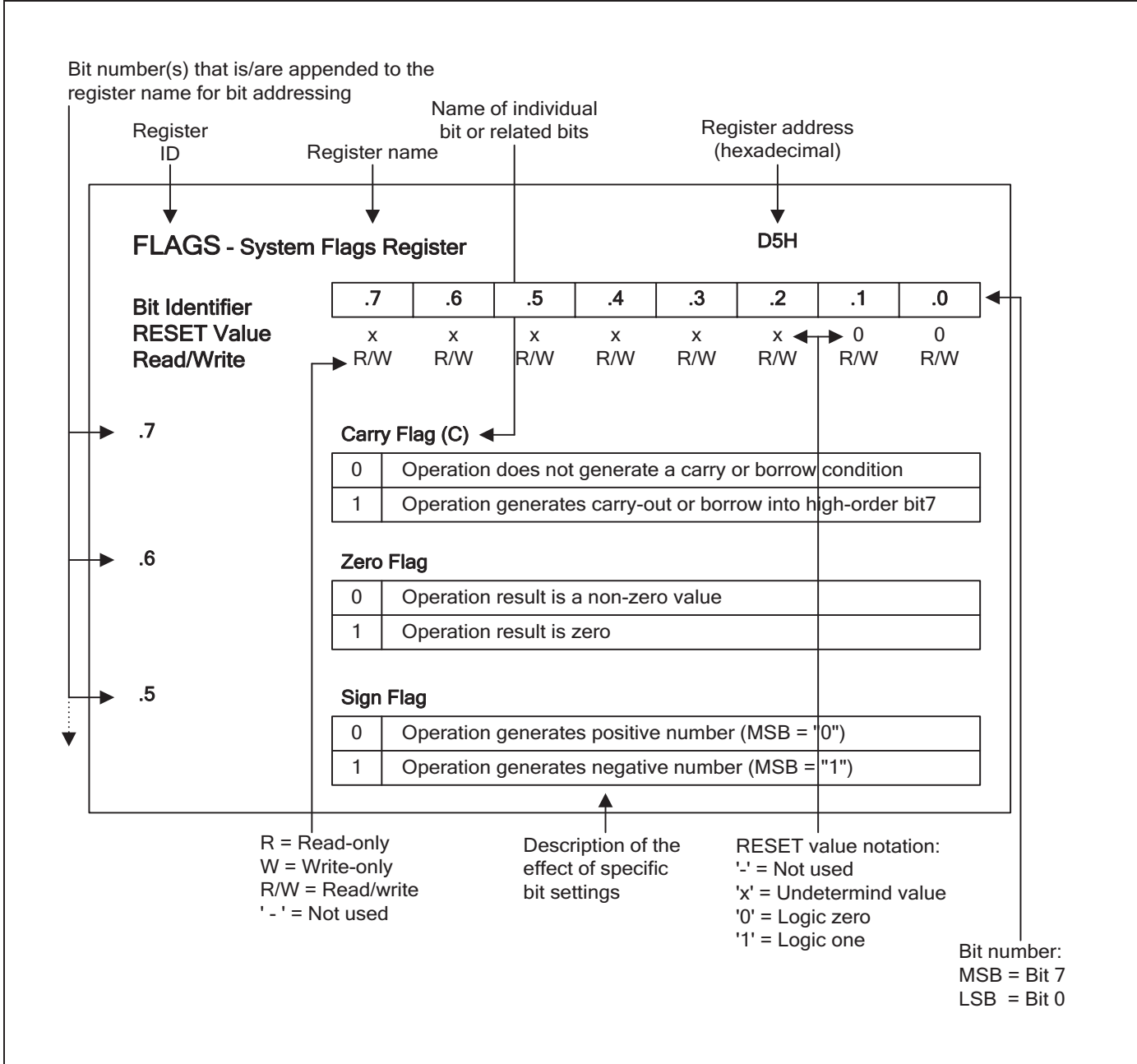


Figure 4-1 Register Description Format

4.1.1 ADCON-A/D Converter Control Register (D2H, SET1)

| Bit Identifier                                   | .7                            | .6                       | .5                   | .4       | .3          | .2  | .1  | .0  |
|--|-------------------------------|--------------------------|----------------------|----------|-------------|-----|-----|-----|
| nRESET Value                                     | 0                             | 0                        | 0                    | 0        | 0           | 0   | 0   | 0   |
| Read/Write                                       | R/W                           | R/W                      | R/W                  | R/W      | R           | R/W | R/W | R/W |
| Addressing Mode                                  | Register addressing mode only |                          |                      |          |             |     |     |     |
| <b>.7– .4 A/D Converter Input Selection Bits</b> |                               |                          |                      |          |             |     |     |     |
|  | 0                             | 0                        | 0                    | 0        | Selects AD0 |     |     |     |
|  | 0                             | 0                        | 0                    | 1        | Selects AD1 |     |     |     |
|  | 0                             | 0                        | 1                    | 0        | Selects AD2 |     |     |     |
|  | 0                             | 0                        | 1                    | 1        | Selects AD3 |     |     |     |
|  | 0                             | 1                        | 0                    | 0        | Selects AD4 |     |     |     |
|  | 0                             | 1                        | 0                    | 1        | Selects AD5 |     |     |     |
|  | 0                             | 1                        | 1                    | 0        | Selects AD6 |     |     |     |
|  | 0                             | 1                        | 1                    | 1        | Selects AD7 |     |     |     |
|  | 1                             | 0                        | 0                    | 0        | Selects AD8 |     |     |     |
|  | 1                             | 0                        | 0                    | 1        | Selects AD9 |     |     |     |
|  | Other values                  |                          |                      | Invalid. |             |     |     |     |
| <b>.3 End-of-conversion Bit (read-only)</b>      |                               |                          |                      |          |             |     |     |     |
|  | 0                             | Conversion not completed |                      |          |             |     |     |     |
|  | 1                             | Conversion completed     |                      |          |             |     |     |     |
| <b>.2– .1 A/D Converter Clock Selection Bits</b> |                               |                          |                      |          |             |     |     |     |
|  | 0                             | 0                        | fosc/16              |          |             |     |     |     |
|  | 0                             | 1                        | fosc/8               |          |             |     |     |     |
|  | 1                             | 0                        | fosc/4               |          |             |     |     |     |
|  | 1                             | 1                        | fosc/1 (fosc < 4MHz) |          |             |     |     |     |
| <b>.0 A/D Converter Start or Disable Bit</b>     |                               |                          |                      |          |             |     |     |     |
|  | 0                             | Disables operation       |                      |          |             |     |     |     |
|  | 1                             | Starts operation         |                      |          |             |     |     |     |

**NOTE:** Maximum ADC clock input = 4 MHz.

4.1.2 BTCON-Basic Timer Control Register (D3H, SET1)

| Bit Identifier   | .7                            | .6   | .5          | .4                              | .3                               | .2  | .1  | .0  |
|--|-------------------------------|--|-------------|---------------------------------|----------------------------------|-----|-----|-----|
| nRESET Value   | 0                             | 0  | 0           | 0                               | 0                                | 0   | 0   | 0   |
| Read/Write   | R/W                           | R/W  | R/W         | R/W                             | R/W                              | R/W | R/W | R/W |
| Addressing Mode  | Register addressing mode only |  |             |                                 |                                  |     |     |     |
| <b>.7– .4 Watchdog Timer Function Disable Code(for System Reset)</b>           |                               |  |             |                                 |                                  |     |     |     |
|  | 1                             | 0  | 1           | 0                               | Disables watchdog timer function |     |     |     |
|  | Others                        |  |             | Enables watchdog timer function |                                  |     |     |     |
| <b>.3– .2 Basic Timer Clock Selection Bits</b>                                 |                               |  |             |                                 |                                  |     |     |     |
|  | 0                             | 0  | fxx/4096    |                                 |                                  |     |     |     |
|  | 0                             | 1  | fxx/1024    |                                 |                                  |     |     |     |
|  | 1                             | 0  | fxx/128     |                                 |                                  |     |     |     |
|  | 1                             | 1  | Invalid bit |                                 |                                  |     |     |     |
| <b>.1 Basic Timer Counter Clear Bit</b>  |                               |  |             |                                 |                                  |     |     |     |
|  | 0                             | No effect  |             |                                 |                                  |     |     |     |
|  | 1                             | Clears the basic timer counter value<br>(Cleared to "0" automatically after being cleared basic timer counter) |             |                                 |                                  |     |     |     |
| <b>.0 Clock Frequency Divider Clear Bit for Basic Timer and Timer Counters</b> |                               |  |             |                                 |                                  |     |     |     |
|  | 0                             | No effect  |             |                                 |                                  |     |     |     |
|  | 1                             | Clears clock frequency dividers<br>(Cleared to "0" automatically after being cleared clock frequency dividers) |             |                                 |                                  |     |     |     |

**NOTE:** When you write a "1" to BTCON.0 (or BTCON.1), the basic timer divider (or basic timer counter) is cleared. The bit is then cleared automatically to "0".

#### 4.1.3 CLKCON-Clock Control Register (D4H, SET1)

| Bit Identifier  | .7                            | .6   | .5     | .4  | .3  | .2 | .1 | .0 |
|---|-------------------------------|--|--------|-----|-----|----|----|----|
| nRESET Value  | 0                             | –  | –      | 0   | 0   | –  | –  | –  |
| Read/Write  | R/W                           | –  | –      | R/W | R/W | –  | –  | –  |
| Addressing Mode                                       | Register addressing mode only |  |        |     |     |    |    |    |
| <b>.7</b>   |                               |  |        |     |     |    |    |    |
| <b>Oscillator IRQ Wake-up Function Bit</b>            |                               |  |        |     |     |    |    |    |
|   | 0                             | Enables IRQ for main wake-up in power down mode  |        |     |     |    |    |    |
|   | 1                             | Disables IRQ for main wake-up in power down mode |        |     |     |    |    |    |
| <b>.6– .5</b>   |                               |  |        |     |     |    |    |    |
| <b>Does not use for the S3F8S19/F8S15</b>             |                               |  |        |     |     |    |    |    |
| <b>.4– .3</b>   |                               |  |        |     |     |    |    |    |
| <b>CPU Clock (System Clock) Selection Bits</b> (NOTE) |                               |  |        |     |     |    |    |    |
|   | 0                             | 0  | fxx/16 |     |     |    |    |    |
|   | 0                             | 1  | fxx/8  |     |     |    |    |    |
|   | 1                             | 0  | fxx/2  |     |     |    |    |    |
|   | 1                             | 1  | fxx    |     |     |    |    |    |
| <b>.2– .0</b>   |                               |  |        |     |     |    |    |    |
| <b>Does not use for the S3F8S19/F8S15</b>             |                               |  |        |     |     |    |    |    |

**NOTE:** After a reset, the slowest clock (divided by 16) is selected as the system clock. To select faster clock speeds, load appropriate values to CLKCON.3 and CLKCON.4

#### 4.1.4 FLAGS-System Flags Register (D5H, SET1)

| Bit Identifier                          | .7                            | .6   | .5  | .4  | .3  | .2  | .1 | .0  |
|---|-------------------------------|--|-----|-----|-----|-----|----|-----|
| Reset Value                             | x                             | x  | x   | x   | x   | x   | 0  | 0   |
| Read/Write                              | R/W                           | R/W  | R/W | R/W | R/W | R/W | R  | R/W |
| Addressing Mode                         | Register addressing mode only |  |     |     |     |     |    |     |
| <b>.7</b>                               |                               |  |     |     |     |     |    |     |
| <b>Carry Flag (C)</b>                   |                               |  |     |     |     |     |    |     |
|   | 0                             | Operation does not generate a carry or borrow condition.                         |     |     |     |     |    |     |
|   | 1                             | Operation generates a carry-out or borrows into high-order bit 7.                |     |     |     |     |    |     |
| <b>.6</b>                               |                               |  |     |     |     |     |    |     |
| <b>Zero Flag (Z)</b>                    |                               |  |     |     |     |     |    |     |
|   | 0                             | Operation result is a non-zero value.  |     |     |     |     |    |     |
|   | 1                             | Operation result is zero.  |     |     |     |     |    |     |
| <b>.5</b>                               |                               |  |     |     |     |     |    |     |
| <b>Sign Flag (S)</b>                    |                               |  |     |     |     |     |    |     |
|   | 0                             | Operation generates a positive number (MSB = "0").                               |     |     |     |     |    |     |
|   | 1                             | Operation generates a negative number (MSB = "1").                               |     |     |     |     |    |     |
| <b>.4</b>                               |                               |  |     |     |     |     |    |     |
| <b>Overflow Flag (V)</b>                |                               |  |     |     |     |     |    |     |
|   | 0                             | Operation result is $\leq +127$ and $> -128$ .                                   |     |     |     |     |    |     |
|   | 1                             | Operation result is $> +127$ or $< -128$ .                                       |     |     |     |     |    |     |
| <b>.3</b>                               |                               |  |     |     |     |     |    |     |
| <b>Decimal Adjust Flag (D)</b>          |                               |  |     |     |     |     |    |     |
|   | 0                             | Completes add operation  |     |     |     |     |    |     |
|   | 1                             | Completes subtraction operation  |     |     |     |     |    |     |
| <b>.2</b>                               |                               |  |     |     |     |     |    |     |
| <b>Half-Carry Flag (H)</b>              |                               |  |     |     |     |     |    |     |
|   | 0                             | No carry-out of bit 3 or no borrow into bit 3 by addition or subtraction         |     |     |     |     |    |     |
|   | 1                             | Addition generated carry-out of bit 3 or subtraction generated borrow into bit 3 |     |     |     |     |    |     |
| <b>.1</b>                               |                               |  |     |     |     |     |    |     |
| <b>Fast Interrupt Status Flag (FIS)</b> |                               |  |     |     |     |     |    |     |
|   | 0                             | Interrupt return (IRET) in progress (when read)                                  |     |     |     |     |    |     |
|   | 1                             | Fast interrupt service routine in progress (when read)                           |     |     |     |     |    |     |
| <b>.0</b>                               |                               |  |     |     |     |     |    |     |
| <b>Bank Address Selection Flag (BA)</b> |                               |  |     |     |     |     |    |     |
|   | 0                             | Selects bank 0   |     |     |     |     |    |     |
|   | 1                             | Selects bank 1   |     |     |     |     |    |     |

4.1.5 FMCON-Flash Memory Control Register (0BH, Page 8)

| Bit Identifier                          | .7                            | .6   | .5  | .4            | .3                | .2 | .1 | .0  |
|---|-------------------------------|--|-----|---------------|-------------------|----|----|-----|
| Reset Value                             | 0                             | 0  | 0   | 0             | 0                 | –  | –  | 0   |
| Read/Write                              | R/W                           | R/W  | R/W | R/W           | R                 | –  | –  | R/W |
| Addressing Mode                         | Register addressing mode only |  |     |               |                   |    |    |     |
| <b>.7– .4</b>                           |                               |  |     |               |                   |    |    |     |
| <b>Flash Memory Mode Selection Bits</b> |                               |  |     |               |                   |    |    |     |
|   | 0                             | 1  | 0   | 1             | Programming mode  |    |    |     |
|   | 1                             | 0  | 1   | 0             | Sector erase mode |    |    |     |
|   | 0                             | 1  | 1   | 0             | Hard lock mode    |    |    |     |
|   | Other values                  |  |     | Not available |                   |    |    |     |
| <b>.3</b>                               |                               |  |     |               |                   |    |    |     |
| <b>Sector Erase Status Bit</b>          |                               |  |     |               |                   |    |    |     |
|   | 0                             | Sector erase success   |     |               |                   |    |    |     |
|   | 1                             | Sector erase fail  |     |               |                   |    |    |     |
| <b>.2– .1</b>                           |                               |  |     |               |                   |    |    |     |
| Not used for the S3F8S19/F8S15          |                               |  |     |               |                   |    |    |     |
| <b>.0</b>                               |                               |  |     |               |                   |    |    |     |
| <b>Flash Operation Start Bit</b>        |                               |  |     |               |                   |    |    |     |
|   | 0                             | Stops operation  |     |               |                   |    |    |     |
|   | 1                             | Starts operation (This bit will be cleared automatically just after the corresponding operator completed). |     |               |                   |    |    |     |



#### 4.1.6 FMSECH-Flash Memory Sector Address Register (High Byte) (08H, Page 8)

| Bit Identifier  | .7                            | .6  | .5  | .4  | .3  | .2  | .1  | .0  |
|---|-------------------------------|-----|-----|-----|-----|-----|-----|-----|
| Reset Value   | 0                             | 0   | 0   | 0   | 0   | 0   | 0   | 0   |
| Read/Write  | R/W                           | R/W | R/W | R/W | R/W | R/W | R/W | R/W |
| Addressing Mode   | Register addressing mode only |     |     |     |     |     |     |     |
| <b>.7– .0 Flash Memory Sector Address Bits (High Byte)</b>              |                               |     |     |     |     |     |     |     |
| 15 <sup>th</sup> - 8 <sup>th</sup> bits to select a sector of flash ROM |                               |     |     |     |     |     |     |     |

**NOTE:** The high-byte flash memory sector address pointer value is the higher eight bits of the 16-bit pointer address.

#### 4.1.7 FMSECL-Flash Memory Sector Address Register (Low Byte) (09H, Page 8)

| Bit Identifier                                       | .7                            | .6  | .5  | .4  | .3  | .2  | .1  | .0  |
|--|-------------------------------|-----|-----|-----|-----|-----|-----|-----|
| Reset Value  | 0                             | 0   | 0   | 0   | 0   | 0   | 0   | 0   |
| Read/Write   | R/W                           | R/W | R/W | R/W | R/W | R/W | R/W | R/W |
| Addressing Mode                                      | Register addressing mode only |     |     |     |     |     |     |     |
| <b>.7 Flash Memory Sector Address Bit (Low Byte)</b> |                               |     |     |     |     |     |     |     |
| Seventh bit to select a sector of flash ROM          |                               |     |     |     |     |     |     |     |
| <b>.6– .0 Bits 6 – 0</b>                             |                               |     |     |     |     |     |     |     |
| Don't care   |                               |     |     |     |     |     |     |     |

**NOTE:** The low-byte flash memory sector address pointer value is the lower eight bits of the 16-bit pointer address.

#### 4.1.8 FMUSR-Flash Memory User Programming Enable Register (0AH, Page 8)

| Bit Identifier  | .7                            | .6  | .5  | .4  | .3  | .2  | .1  | .0  |
|---|-------------------------------|-----|-----|-----|-----|-----|-----|-----|
| Reset Value   | 0                             | 0   | 0   | 0   | 0   | 0   | 0   | 0   |
| Read/Write  | R/W                           | R/W | R/W | R/W | R/W | R/W | R/W | R/W |
| Addressing Mode   | Register addressing mode only |     |     |     |     |     |     |     |
| <b>.7– .0 Flash Memory User Programming Enable Bits</b> |                               |     |     |     |     |     |     |     |
| 1 0 1 0 0 1 0 1   |                               |     |     |     |     |     |     |     |
| Enables user programming mode                           |                               |     |     |     |     |     |     |     |
| Other values  |                               |     |     |     |     |     |     |     |
| Disables user programming mode                          |                               |     |     |     |     |     |     |     |

4.1.9 ICCR-Multi-Master IIC-Bus Clock Control Register (0CH, PAGE8)

| Bit Identifier  | .7  | .6   | .5  | .4  | .3  | .2  | .1  | .0  |
|---|---|--|-----|-----|-----|-----|-----|-----|
| nRESET Value  | 0   | 0  | 0   | 0   | 1   | 1   | 1   | 1   |
| Read/Write  | R/W   | R/W  | R/W | R/W | R/W | R/W | R/W | R/W |
| Addressing Mode   | Register addressing mode only   |  |     |     |     |     |     |     |
| <b>.7 Acknowledgement Enable Bit</b>                        |   |  |     |     |     |     |     |     |
|   | 0   | Acknowledges disable mode  |     |     |     |     |     |     |
|   | 1   | Acknowledges enable mode   |     |     |     |     |     |     |
| <b>.6 Tx Clock Selection Bit</b>                            |   |  |     |     |     |     |     |     |
|   | 0   | fosc/16  |     |     |     |     |     |     |
|   | 1   | fosc/512   |     |     |     |     |     |     |
| <b>.5 Multi-master IIC-Bus Tx/Rx Interrupt Enable Bit</b>   |   |  |     |     |     |     |     |     |
|   | 0   | Disables   |     |     |     |     |     |     |
|   | 1   | Enables  |     |     |     |     |     |     |
| <b>.4 Multi-master</b>                                      |   |  |     |     |     |     |     |     |
|   | 0   | Interrupt request is not pending; (when read) pending bit clear when write 0 |     |     |     |     |     |     |
|   | 1   | Interrupt request is pending (when read)                                     |     |     |     |     |     |     |
| <b>.3– .0 ICCR.3-0: Transmit Clock 4-bit Prescaler Bits</b> |   |  |     |     |     |     |     |     |
|   | $SCL\ clock = IICLK/CCR<3:0> + 1$<br>where, IICLK = fosc/16 when IICR.6 is "0", IICLK = fosc/512 when ICCR.6 is "1" |  |     |     |     |     |     |     |

4.1.10 ICSR-IIC Status Register (0DH, PAGE 8)

| Bit Identifier                                | .7   | .6  | .5                                 | .4  | .3  | .2  | .1  | .0  |
|---|--|---|------------------------------------|-----|-----|-----|-----|-----|
| nRESET Value                                  | 0  | 0   | 0                                  | 0   | 0   | 0   | 0   | 0   |
| Read/Write                                    | R/W  | R/W   | R/W                                | R/W | R/W | R/W | R/W | R/W |
| Addressing Mode                               | Register addressing mode only  |   |                                    |     |     |     |     |     |
| <b>.7– .6 Acknowledgement Enable Bit</b>      |  |   |                                    |     |     |     |     |     |
|   | 0  | 0   | Slave receiver mode (Default mode) |     |     |     |     |     |
|   | 0  | 1   | Slave transmitter mode             |     |     |     |     |     |
|   | 1  | 0   | Master receiver mode               |     |     |     |     |     |
|   | 1  | 1   | Master transmitter mode            |     |     |     |     |     |
| <b>.5 IIC-Bus Busy Bit</b>                    |  |   |                                    |     |     |     |     |     |
|   | 0  | IIC-bus is not busy   |                                    |     |     |     |     |     |
|   | 0  | Stops condition generation  |                                    |     |     |     |     |     |
|   | 1  | IIC-bus is busy (when read)   |                                    |     |     |     |     |     |
|   | 1  | Stops condition generation (when write)                                 |                                    |     |     |     |     |     |
| <b>.4 IIC-bus Interface Module Enable Bit</b> |  |   |                                    |     |     |     |     |     |
|   | 0  | Disables IIC-bus data transmit/receive                                  |                                    |     |     |     |     |     |
|   | 1  | Enables IIC-bus data transmit/receive                                   |                                    |     |     |     |     |     |
| <b>.3 Arbitration Lost Bit</b>                |  |   |                                    |     |     |     |     |     |
|   | Hardware sets this bit when the serial I/O interface in master transmit mode loses a bus arbitration procedure. In slave mode this flag is set to "1" when ICCR.5 is "1" and ICSR.2 is "0" |   |                                    |     |     |     |     |     |
| <b>.2 Address Match Bit</b>                   |  |   |                                    |     |     |     |     |     |
|   | 0  | When Start or Stop or Reset condition was generated                     |                                    |     |     |     |     |     |
|   | 1  | When the received slave address matches to IAR register or general call |                                    |     |     |     |     |     |
| <b>.1 General Call Bit</b>                    |  |   |                                    |     |     |     |     |     |
|   | 0  | When Start/Stop condition is generated                                  |                                    |     |     |     |     |     |
|   | 1  | When the received slave address is "00000000" (general call)            |                                    |     |     |     |     |     |
| <b>.0 Received Acknowledge Bit</b>            |  |   |                                    |     |     |     |     |     |
|   | 0  | Receives ACK  |                                    |     |     |     |     |     |
|   | 1  | Does not receive ACK  |                                    |     |     |     |     |     |

4.1.11 IMR-Interrupt Mask Register (DDH, SET1)

| Bit Identifier | .7                              | .6                | .5  | .4  | .3  | .2  | .1  | .0  |
|----------------|---------------------------------|-------------------|-----|-----|-----|-----|-----|-----|
| Reset Value    | x                               | x                 | x   | x   | x   | x   | x   | x   |
| Read/Write     | R/W                             | R/W               | R/W | R/W | R/W | R/W | R/W | R/W |
| <b>.7</b>      | <b>Interrupt Level 7 (IRQ7)</b> |                   |     |     |     |     |     |     |
|                | 0                               | Disables (masks)  |     |     |     |     |     |     |
|                | 1                               | Enables (unmasks) |     |     |     |     |     |     |
| <b>.6</b>      | <b>Interrupt Level 6 (IRQ6)</b> |                   |     |     |     |     |     |     |
|                | 0                               | Disables (masks)  |     |     |     |     |     |     |
|                | 1                               | Enables (unmasks) |     |     |     |     |     |     |
| <b>.5</b>      | <b>Interrupt Level 5 (IRQ5)</b> |                   |     |     |     |     |     |     |
|                | 0                               | Disables (masks)  |     |     |     |     |     |     |
|                | 1                               | Enables (unmasks) |     |     |     |     |     |     |
| <b>.4</b>      | <b>Interrupt Level 4 (IRQ4)</b> |                   |     |     |     |     |     |     |
|                | 0                               | Disables (masks)  |     |     |     |     |     |     |
|                | 1                               | Enables (unmasks) |     |     |     |     |     |     |
| <b>.3</b>      | <b>Interrupt Level 3 (IRQ3)</b> |                   |     |     |     |     |     |     |
|                | 0                               | Disables (masks)  |     |     |     |     |     |     |
|                | 1                               | Enables (unmasks) |     |     |     |     |     |     |
| <b>.2</b>      | <b>Interrupt Level 2 (IRQ2)</b> |                   |     |     |     |     |     |     |
|                | 0                               | Disables (masks)  |     |     |     |     |     |     |
|                | 1                               | Enables (unmasks) |     |     |     |     |     |     |
| <b>.1</b>      | <b>Interrupt Level 1 (IRQ1)</b> |                   |     |     |     |     |     |     |
|                | 0                               | Disables (masks)  |     |     |     |     |     |     |
|                | 1                               | Enables (unmasks) |     |     |     |     |     |     |
| <b>.0</b>      | <b>Interrupt Level 0 (IRQ0)</b> |                   |     |     |     |     |     |     |
|                | 0                               | Disables (masks)  |     |     |     |     |     |     |
|                | 1                               | Enables (unmasks) |     |     |     |     |     |     |

**NOTE:** When an interrupt level is masked, the CPU does not recognize any interrupt requests that may be issued.

#### 4.1.12 IPH-Instruction Pointer (High Byte) (DAH, SET1)

| Bit Identifier   | .7  | .6  | .5  | .4  | .3  | .2  | .1  | .0  |
|--|-----|-----|-----|-----|-----|-----|-----|-----|
| Reset Value  | x   | x   | x   | x   | x   | x   | x   | x   |
| Read/Write   | R/W | R/W | R/W | R/W | R/W | R/W | R/W | R/W |
| <b>.7– .0</b>  |     |     |     |     |     |     |     |     |
| <b>Instruction Pointer Address (High Byte)</b>   |     |     |     |     |     |     |     |     |
| The high-byte instruction pointer value is the upper 8 bits of the 16-bit instruction pointer address (IP15–IP8). The lower byte of the IP address is located in the IPL register (DBH). |     |     |     |     |     |     |     |     |

#### 4.1.13 IPL-Instruction Pointer (Low Byte) (DBH, SET1)

| Bit Identifier   | .7  | .6  | .5  | .4  | .3  | .2  | .1  | .0  |
|--|-----|-----|-----|-----|-----|-----|-----|-----|
| Reset Value  | x   | x   | x   | x   | x   | x   | x   | x   |
| Read/Write   | R/W | R/W | R/W | R/W | R/W | R/W | R/W | R/W |
| <b>.7– .0</b>  |     |     |     |     |     |     |     |     |
| <b>Instruction Pointer Address (Low Byte)</b>  |     |     |     |     |     |     |     |     |
| The low-byte instruction pointer value is the lower 8 bits of the 16-bit instruction pointer address (IP7–IP0). The upper byte of the IP address is located in the IPH register (DAH). |     |     |     |     |     |     |     |     |

4.1.14 IPR-Interrupt Priority Register (FFH, BANK0)

| Bit Identifier       | .7   | .6                  | .5  | .4                       | .3  | .2  | .1  | .0  |
|----------------------|--|---------------------|-----|--------------------------|-----|-----|-----|-----|
| Reset Value          | x  | x                   | x   | x                        | x   | x   | x   | x   |
| Read/Write           | R/W  | R/W                 | R/W | R/W                      | R/W | R/W | R/W | R/W |
| <b>.7, .4 and .1</b> | <b>Priority Control Bits for Interrupt Groups A, B, and C (NOTE)</b> |                     |     |                          |     |     |     |     |
|                      | 0  | 0                   | 0   | Group priority undefined |     |     |     |     |
|                      | 0  | 0                   | 1   | B > C > A                |     |     |     |     |
|                      | 0  | 1                   | 0   | A > B > C                |     |     |     |     |
|                      | 0  | 1                   | 1   | B > A > C                |     |     |     |     |
|                      | 1  | 0                   | 0   | C > A > B                |     |     |     |     |
|                      | 1  | 0                   | 1   | C > B > A                |     |     |     |     |
|                      | 1  | 1                   | 0   | A > C > B                |     |     |     |     |
|                      | 1  | 1                   | 1   | Group priority undefined |     |     |     |     |
| <b>.6</b>            | <b>Interrupt Subgroup C Priority Control Bit</b>                     |                     |     |                          |     |     |     |     |
|                      | 0  | IRQ6 > IRQ7         |     |                          |     |     |     |     |
|                      | 1  | IRQ7 > IRQ6         |     |                          |     |     |     |     |
| <b>.5</b>            | <b>Interrupt Group C Priority Control Bit</b>                        |                     |     |                          |     |     |     |     |
|                      | 0  | IRQ5 > (IRQ6, IRQ7) |     |                          |     |     |     |     |
|                      | 1  | (IRQ6, IRQ7) > IRQ5 |     |                          |     |     |     |     |
| <b>.3</b>            | <b>Interrupt Subgroup B Priority Control Bit</b>                     |                     |     |                          |     |     |     |     |
|                      | 0  | IRQ3 > IRQ4         |     |                          |     |     |     |     |
|                      | 1  | IRQ4 > IRQ3         |     |                          |     |     |     |     |
| <b>.2</b>            | <b>Interrupt Group B Priority Control Bit</b>                        |                     |     |                          |     |     |     |     |
|                      | 0  | IRQ2 > (IRQ3, IRQ4) |     |                          |     |     |     |     |
|                      | 1  | (IRQ3, IRQ4) > IRQ2 |     |                          |     |     |     |     |
| <b>.0</b>            | <b>Interrupt Group A Priority Control Bit</b>                        |                     |     |                          |     |     |     |     |
|                      | 0  | IRQ0 > IRQ1         |     |                          |     |     |     |     |
|                      | 1  | IRQ1 > IRQ0         |     |                          |     |     |     |     |

**NOTE:** Interrupt Group A - IRQ0, IRQ1  
 Interrupt Group B - IRQ2, IRQ3, IRQ4  
 Interrupt Group C - IRQ5, IRQ6, IRQ7

4.1.15 IRQ-Interrupt Request Register (DCH, SET1)

| Bit Identifier | .7   | .6          | .5 | .4 | .3 | .2 | .1 | .0 |
|----------------|--|-------------|----|----|----|----|----|----|
| Reset Value    | 0  | 0           | 0  | 0  | 0  | 0  | 0  | 0  |
| Read/Write     | R  | R           | R  | R  | R  | R  | R  | R  |
| <b>.7</b>      | <b>Level 7 (IRQ7) Request Pending Bit;</b> |             |    |    |    |    |    |    |
|                | 0  | Not pending |    |    |    |    |    |    |
|                | 1  | Pending     |    |    |    |    |    |    |
| <b>.6</b>      | <b>Level 6 (IRQ6) Request Pending Bit;</b> |             |    |    |    |    |    |    |
|                | 0  | Not pending |    |    |    |    |    |    |
|                | 1  | Pending     |    |    |    |    |    |    |
| <b>.5</b>      | <b>Level 5 (IRQ5) Request Pending Bit;</b> |             |    |    |    |    |    |    |
|                | 0  | Not pending |    |    |    |    |    |    |
|                | 1  | Pending     |    |    |    |    |    |    |
| <b>.4</b>      | <b>Level 4 (IRQ4) Request Pending Bit;</b> |             |    |    |    |    |    |    |
|                | 0  | Not pending |    |    |    |    |    |    |
|                | 1  | Pending     |    |    |    |    |    |    |
| <b>.3</b>      | <b>Level 3 (IRQ3) Request Pending Bit;</b> |             |    |    |    |    |    |    |
|                | 0  | Not pending |    |    |    |    |    |    |
|                | 1  | Pending     |    |    |    |    |    |    |
| <b>.2</b>      | <b>Level 2 (IRQ2) Request Pending Bit;</b> |             |    |    |    |    |    |    |
|                | 0  | Not pending |    |    |    |    |    |    |
|                | 1  | Pending     |    |    |    |    |    |    |
| <b>.1</b>      | <b>Level 1 (IRQ1) Request Pending Bit;</b> |             |    |    |    |    |    |    |
|                | 0  | Not pending |    |    |    |    |    |    |
|                | 1  | Pending     |    |    |    |    |    |    |
| <b>.0</b>      | <b>Level 0 (IRQ0) Request Pending Bit;</b> |             |    |    |    |    |    |    |
|                | 0  | Not pending |    |    |    |    |    |    |
|                | 1  | Pending     |    |    |    |    |    |    |

#### 4.1.16 LCON-LCD Control Register (FDH, BANK1)

| Bit Identifier                                    | .7                            | .6  | .5   | .4                 | .3  | .2  | .1  | .0  |
|---|-------------------------------|---|--|--------------------|-----|-----|-----|-----|
| nRESET Value                                      | 0                             | 0   | 0  | 0                  | 0   | 0   | 0   | 0   |
| Read/Write  | R/W                           | R/W   | R/W  | R/W                | R/W | R/W | R/W | R/W |
| Addressing Mode                                   | Register addressing mode only |   |  |                    |     |     |     |     |
| <b>.7– .6 LCD Clock Selection Bits</b>            |                               |   |  |                    |     |     |     |     |
|   | 0                             | 0   | fw/28 (128 Hz)   |                    |     |     |     |     |
|   | 0                             | 1   | fw/27 (256 Hz)   |                    |     |     |     |     |
|   | 1                             | 0   | fw/26 (512 Hz)   |                    |     |     |     |     |
|   | 1                             | 1   | fw/25 (1024 Hz)  |                    |     |     |     |     |
| <b>.5– .3 LCD Duty and Bias Selection Bits</b>    |                               |   |  |                    |     |     |     |     |
|   | 0                             | 0   | 0  | 1/8 duty, 1/4 bias |     |     |     |     |
|   | 0                             | 0   | 1  | 1/4 duty, 1/3 bias |     |     |     |     |
|   | 0                             | 1   | 0  | 1/3 duty, 1/3 bias |     |     |     |     |
|   | 0                             | 1   | 1  | 1/3 duty, 1/2 bias |     |     |     |     |
|   | 1                             | x   | x  | 1/2 duty, 1/2 bias |     |     |     |     |
| NOTE: "x" means don't care.                       |                               |   |  |                    |     |     |     |     |
| <b>.2– .1 LCD Bias Type Selection Bits (NOTE)</b> |                               |   |  |                    |     |     |     |     |
|   | 0                             | 0   | LCD invalid.<br>(VLC0 – VLC3, CA and CB are normal pins Input/Output (I/O pin))  |                    |     |     |     |     |
|   | 0                             | 1   | Capacitor bias.<br>(VLC0 – VLC3, CA and CB are bias pins)  |                    |     |     |     |     |
|   | 1                             | 0   | Internal resistor bias. (The voltage booster is always stopped and cut off;<br>VLC0 – VLC3, CA and CB are normal pins I/O pin)             |                    |     |     |     |     |
|   | 1                             | 1   | External resistor bias. (The voltage booster is always stopped and cut off;<br>VLC0 – VLC3 are bias pins, CA and CB s are normal I/O pins) |                    |     |     |     |     |
| <b>.0 LCD Display Control Bit</b>                 |                               |   |  |                    |     |     |     |     |
|   | 0                             | All LCD signals are low (The voltage booster is always stopped and cut off) |  |                    |     |     |     |     |
|   | 1                             | Turn display on (When LCON.2-.1 = "01", run and connect voltage booster)    |  |                    |     |     |     |     |

**NOTE:**

- When LCON.2-.1 is selected to "01", P1.0-.5 is automatically selected to VLCn, CA and CB pin. (n = 0-3)  
When LCON.2-.1 is capacitor bias selected, LCON.0 is select to "1" after 1 millisecond delay.  
Refer to the program tip in Chapter 15 for more information.
- When LCON.2-.1 is selected to "10", P1.0-.5 depends on P1CONH/L register.
- When LCON.2-.1 are selected to "11", P1.2-.5 are automatically selected to VLCn. (n = 0-3)  
CA and CB pins depend on P1CONL register.



4.1.17 LMOD-LCD Mode Control Register (FCH, BANK1)

| Bit Identifier  | .7   | .6 | .5 | .4          | .3 | .2  | .1  | .0  |
|-----------------|--|----|----|-------------|----|-----|-----|-----|
| nRESET Value    | –  | –  | –  | –           | –  | 0   | 0   | 0   |
| Read/Write      | –  | –  | –  | –           | –  | R/W | R/W | R/W |
| Addressing Mode | Register addressing mode only  |    |    |             |    |     |     |     |
|                 |  |    |    |             |    |     |     |     |
| .7– .3          | Not used but keep always "0"   |    |    |             |    |     |     |     |
|                 |  |    |    |             |    |     |     |     |
| .2– .0          | VLCD Voltage Selection Bits (Only when the capacitor bias is selected) |    |    |             |    |     |     |     |
|                 | Values   |    |    | 1/4 Bias[V] |    |     |     |     |
|                 | 0  | 0  | 0  | 3.6 V       |    |     |     |     |
|                 | 0  | 0  | 1  | 3.8 V       |    |     |     |     |
|                 | 0  | 1  | 0  | 4.0 V       |    |     |     |     |
|                 | 0  | 1  | 1  | 4.2 V       |    |     |     |     |
|                 | 1  | 0  | 0  | 4.4 V       |    |     |     |     |
|                 | 1  | 0  | 1  | 4.6 V       |    |     |     |     |
|                 | 1  | 1  | 0  | 4.8 V       |    |     |     |     |

| Bit Identifier                              | .7  | .6                     | .5           | .4  | .3 | .2 | .1  | .0  |
|---|-----|------------------------|--------------|-----|----|----|-----|-----|
| Reset Value                                 | 0   | –                      | 0            | 0   | –  | –  | 0   | 0   |
| Read/Write                                  | R/W | –                      | R            | R/W | –  | –  | R/W | R/W |
| <b>.7</b>                                   |     |                        |              |     |    |    |     |     |
| Low voltage detect (LVD) Enable/Disable Bit |     |                        |              |     |    |    |     |     |
|   | 0   | Disables LVD           |              |     |    |    |     |     |
|   | 1   | Enables LVD            |              |     |    |    |     |     |
| <b>.6</b>                                   |     |                        |              |     |    |    |     |     |
| Not Used for S3F8S19/F8S15                  |     |                        |              |     |    |    |     |     |
| <b>.5</b>                                   |     |                        |              |     |    |    |     |     |
| LVD Output Bit (Read Only)                  |     |                        |              |     |    |    |     |     |
|   | 0   | VDD > VLVD             |              |     |    |    |     |     |
|   | 1   | VDD < VLVD             |              |     |    |    |     |     |
| <b>.4</b>                                   |     |                        |              |     |    |    |     |     |
| LVD Interrupt Enable/Disable Bit            |     |                        |              |     |    |    |     |     |
|   | 0   | Disables LVD interrupt |              |     |    |    |     |     |
|   | 1   | Enables LVD interrupt  |              |     |    |    |     |     |
| <b>.3– .2</b>                               |     |                        |              |     |    |    |     |     |
| Not Used for S3F8S19/F8S15                  |     |                        |              |     |    |    |     |     |
| <b>.1– .0</b>                               |     |                        |              |     |    |    |     |     |
| Detection Voltage Level Selection Bits      |     |                        |              |     |    |    |     |     |
|   | 0   | 0                      | VLVD = 4.1 V |     |    |    |     |     |
|   | 0   | 1                      | VLVD = 3.2 V |     |    |    |     |     |
|   | 1   | 0                      | VLVD = 2.5 V |     |    |    |     |     |
|   | 1   | 1                      | VLVD = 2.1 V |     |    |    |     |     |

| Bit Identifier  | .7                                    | .6                                       | .5  | .4  | .3  | .2  | .1 | .0  |
|-----------------|---------------------------------------|--|-----|-----|-----|-----|----|-----|
| nRESET Value    | –                                     | –  | 0   | 0   | 0   | 0   | –  | 0   |
| Read/Write      | –                                     | –  | R/W | R/W | R/W | R/W | –  | R/W |
| Addressing Mode | Register addressing mode only         |  |     |     |     |     |    |     |
| .7– .4          | <b>Not used for the S3F8S19/F8S15</b> |  |     |     |     |     |    |     |
| .3              | <b>Main Oscillator Control Bit</b>    |  |     |     |     |     |    |     |
|                 | 0                                     | RUNS main oscillator                     |     |     |     |     |    |     |
|                 | 1                                     | STOPS main oscillator                    |     |     |     |     |    |     |
| .2              | <b>Sub Oscillator Control Bit</b>     |  |     |     |     |     |    |     |
|                 | 0                                     | RUNS sub oscillator                      |     |     |     |     |    |     |
|                 | 1                                     | STOPS sub oscillator                     |     |     |     |     |    |     |
| .1              | <b>Not used for the S3F8S19/F8S15</b> |  |     |     |     |     |    |     |
| .0              | <b>System Clock Selection Bit</b>     |  |     |     |     |     |    |     |
|                 | 0                                     | Selects main oscillator for system clock |     |     |     |     |    |     |
|                 | 1                                     | Selects sub oscillator for system clock  |     |     |     |     |    |     |

**NOTE:** Only both main oscillator and sub oscillator are normally connected, OSCCON operation is effective.

#### 4.1.20 OSCCALCON-Internal OSC Calibration Control Register (18H, PAGE8)

| Bit Identifier | .7   | .6  | .5                                 | .4  | .3  | .2  | .1  | .0  |
|----------------|--|-----|------------------------------------|-----|-----|-----|-----|-----|
| nRESET Value   | 0  | 0   | 0                                  | 0   | 0   | 0   | 0   | 0   |
| Read/Write     | R/W  | R/W | R/W                                | R/W | R/W | R/W | R/W | R/W |
| .7– .0         | <b>Internal OSC Calibration Control Bits</b> |     |                                    |     |     |     |     |     |
|                | 10100101                                     |     | Enables OSCCALDATA register write  |     |     |     |     |     |
|                | Other value                                  |     | Disables OSCCALDATA register write |     |     |     |     |     |

**NOTE:** Before writing OSCCALDATA register, you should set this OSCCALCON register as "10100101b".

| Bit Identifier                            | .7                            | .6  | .5                            | .4  | .3  | .2  | .1  | .0  |
|---|-------------------------------|-----|-------------------------------|-----|-----|-----|-----|-----|
| nRESET Value                              | 0                             | 0   | 0                             | 0   | 0   | 0   | 0   | 0   |
| Read/Write                                | R/W                           | R/W | R/W                           | R/W | R/W | R/W | R/W | R/W |
| Addressing Mode                           | Register addressing mode only |     |                               |     |     |     |     |     |
| <b>.7– .6 P0.7/AD7 Configuration Bits</b> |                               |     |                               |     |     |     |     |     |
|   | 0                             | 0   | Schmitt trigger input mode    |     |     |     |     |     |
|   | 0                             | 1   | Alternative function (TAOUT)  |     |     |     |     |     |
|   | 1                             | 0   | Alternative function (AD7)    |     |     |     |     |     |
|   | 1                             | 1   | Push-pull output mode         |     |     |     |     |     |
| <b>.5– .4 P0.6/AD6 Configuration Bits</b> |                               |     |                               |     |     |     |     |     |
|   | 0                             | 0   | Schmitt trigger input mode    |     |     |     |     |     |
|   | 0                             | 1   | Alternative function (TBOOUT) |     |     |     |     |     |
|   | 1                             | 0   | Alternative function (AD6)    |     |     |     |     |     |
|   | 1                             | 1   | Push-pull output mode         |     |     |     |     |     |
| <b>.3– .2 P0.5/AD5 Configuration Bits</b> |                               |     |                               |     |     |     |     |     |
|   | 0                             | 0   | Schmitt trigger input mode    |     |     |     |     |     |
|   | 0                             | 1   | Alternative function (T0OUT)  |     |     |     |     |     |
|   | 1                             | 0   | Alternative function (AD5)    |     |     |     |     |     |
|   | 1                             | 1   | Push-pull output mode         |     |     |     |     |     |
| <b>.1– .0 P0.4/AD4 Configuration Bits</b> |                               |     |                               |     |     |     |     |     |
|   | 0                             | 0   | Schmitt trigger input mode    |     |     |     |     |     |
|   | 0                             | 1   | Alternative function (T1OUT)  |     |     |     |     |     |
|   | 1                             | 0   | Alternative function (AD4)    |     |     |     |     |     |
|   | 1                             | 1   | Push-pull output mode         |     |     |     |     |     |

|   |                               |           |                              |           |           |           |           |           |
|---|-------------------------------|-----------|------------------------------|-----------|-----------|-----------|-----------|-----------|
| <b>Bit Identifier</b>                     | <b>.7</b>                     | <b>.6</b> | <b>.5</b>                    | <b>.4</b> | <b>.3</b> | <b>.2</b> | <b>.1</b> | <b>.0</b> |
| <b>nRESET Value</b>                       | 0                             | 0         | 0                            | 0         | 0         | 0         | 0         | 0         |
| <b>Read/Write</b>                         | R/W                           | R/W       | R/W                          | R/W       | R/W       | R/W       | R/W       | R/W       |
| <b>Addressing Mode</b>                    | Register addressing mode only |           |                              |           |           |           |           |           |
| <b>.7– .6 P0.3/AD3 Configuration Bits</b> |                               |           |                              |           |           |           |           |           |
|   | 0                             | 0         | Schmitt trigger input mode   |           |           |           |           |           |
|   | 0                             | 1         | Alternative function (T2OUT) |           |           |           |           |           |
|   | 1                             | 0         | Alternative function (AD3)   |           |           |           |           |           |
|   | 1                             | 1         | Push-pull output mode        |           |           |           |           |           |
| <b>.5– .4 P0.2/AD2 Configuration Bits</b> |                               |           |                              |           |           |           |           |           |
|   | 0                             | 0         | Schmitt trigger input mode   |           |           |           |           |           |
|   | 0                             | 1         | Not used                     |           |           |           |           |           |
|   | 1                             | 0         | Alternative function (AD2)   |           |           |           |           |           |
|   | 1                             | 1         | Push-pull output mode        |           |           |           |           |           |
| <b>.3– .2 P0.1/AD1 Configuration Bits</b> |                               |           |                              |           |           |           |           |           |
|   | 0                             | 0         | Schmitt trigger input mode   |           |           |           |           |           |
|   | 0                             | 1         | Not used                     |           |           |           |           |           |
|   | 1                             | 0         | Alternative function (AD1)   |           |           |           |           |           |
|   | 1                             | 1         | Push-pull output mode        |           |           |           |           |           |
| <b>.1– .0 P0.0/AD0 Configuration Bits</b> |                               |           |                              |           |           |           |           |           |
|   | 0                             | 0         | Schmitt trigger input mode   |           |           |           |           |           |
|   | 0                             | 1         | Alternative function (BUZ)   |           |           |           |           |           |
|   | 1                             | 0         | Alternative function (AD0)   |           |           |           |           |           |
|   | 1                             | 1         | Push-pull output mode        |           |           |           |           |           |

| Bit Identifier  | .7  | .6                        | .5  | .4  | .3  | .2  | .1  | .0  |
|-----------------|---|---------------------------|-----|-----|-----|-----|-----|-----|
| nRESET Value    | 0   | 0                         | 0   | 0   | 0   | 0   | 0   | 0   |
| Read/Write      | R/W                                       | R/W                       | R/W | R/W | R/W | R/W | R/W | R/W |
| Addressing Mode | Register addressing mode only             |                           |     |     |     |     |     |     |
| <b>.7</b>       | <b>P0.7's Pull-up Resistor Enable Bit</b> |                           |     |     |     |     |     |     |
|                 | 0   | Disables pull-up resistor |     |     |     |     |     |     |
|                 | 1   | Enables pull-up resistor  |     |     |     |     |     |     |
| <b>.6</b>       | <b>P0.6's Pull-up Resistor Enable Bit</b> |                           |     |     |     |     |     |     |
|                 | 0   | Disables pull-up resistor |     |     |     |     |     |     |
|                 | 1   | Enables pull-up resistor  |     |     |     |     |     |     |
| <b>.5</b>       | <b>P0.5's Pull-up Resistor Enable Bit</b> |                           |     |     |     |     |     |     |
|                 | 0   | Disables pull-up resistor |     |     |     |     |     |     |
|                 | 1   | Enables pull-up resistor  |     |     |     |     |     |     |
| <b>.4</b>       | <b>P0.4's Pull-up Resistor Enable Bit</b> |                           |     |     |     |     |     |     |
|                 | 0   | Disables pull-up resistor |     |     |     |     |     |     |
|                 | 1   | Enables pull-up resistor  |     |     |     |     |     |     |
| <b>.3</b>       | <b>P0.3's Pull-up Resistor Enable Bit</b> |                           |     |     |     |     |     |     |
|                 | 0   | Disables pull-up resistor |     |     |     |     |     |     |
|                 | 1   | Enables pull-up resistor  |     |     |     |     |     |     |
| <b>.2</b>       | <b>P0.2's Pull-up Resistor Enable Bit</b> |                           |     |     |     |     |     |     |
|                 | 0   | Disables pull-up resistor |     |     |     |     |     |     |
|                 | 1   | Enables pull-up resistor  |     |     |     |     |     |     |
| <b>.1</b>       | <b>P0.1's Pull-up Resistor Enable Bit</b> |                           |     |     |     |     |     |     |
|                 | 0   | Disables pull-up resistor |     |     |     |     |     |     |
|                 | 1   | Enables pull-up resistor  |     |     |     |     |     |     |
| <b>.0</b>       | <b>P0.0's Pull-up Resistor Enable Bit</b> |                           |     |     |     |     |     |     |
|                 | 0   | Disables pull-up resistor |     |     |     |     |     |     |
|                 | 1   | Enables pull-up resistor  |     |     |     |     |     |     |

**NOTE:** A pull-up resistor of port 0 is automatically disabled only when the corresponding pin is selected as push-pull output or alternative function.

| Bit Identifier   | .7                            | .6  | .5   | .4  | .3  | .2  | .1  | .0  |
|--|-------------------------------|-----|--|-----|-----|-----|-----|-----|
| nRESET Value   | 0                             | 0   | 0  | 0   | 0   | 0   | 0   | 0   |
| Read/Write   | R/W                           | R/W | R/W  | R/W | R/W | R/W | R/W | R/W |
| Addressing Mode  | Register addressing mode only |     |  |     |     |     |     |     |
| <b>.7– .6 P0.3 (INT3) External Interrupt Configuration Bit</b> |                               |     |  |     |     |     |     |     |
|  | 0                             | 0   | Disables interrupt                                     |     |     |     |     |     |
|  | 0                             | 1   | Enables interrupt; interrupt on falling edge           |     |     |     |     |     |
|  | 1                             | 0   | Enables interrupt; interrupt on rising edge            |     |     |     |     |     |
|  | 1                             | 1   | Enables interrupt; interrupt on rising or falling edge |     |     |     |     |     |
| <b>.5– .4 P0.2 (INT2) External Interrupt Configuration Bit</b> |                               |     |  |     |     |     |     |     |
|  | 0                             | 0   | Disables interrupt                                     |     |     |     |     |     |
|  | 0                             | 1   | Enables interrupt; interrupt on falling edge           |     |     |     |     |     |
|  | 1                             | 0   | Enables interrupt; interrupt on rising edge            |     |     |     |     |     |
|  | 1                             | 1   | Enables interrupt; interrupt on rising or falling edge |     |     |     |     |     |
| <b>.3– .2 P0.1 (INT1) External Interrupt Configuration Bit</b> |                               |     |  |     |     |     |     |     |
|  | 0                             | 0   | Disables interrupt                                     |     |     |     |     |     |
|  | 0                             | 1   | Enables interrupt; interrupt on falling edge           |     |     |     |     |     |
|  | 1                             | 0   | Enables interrupt; interrupt on rising edge            |     |     |     |     |     |
|  | 1                             | 1   | Enables interrupt; interrupt on rising or falling edge |     |     |     |     |     |
| <b>.1– .0 P0.0 (INT0) External Interrupt Configuration Bit</b> |                               |     |  |     |     |     |     |     |
|  | 0                             | 0   | Disables interrupt                                     |     |     |     |     |     |
|  | 0                             | 1   | Enables interrupt; interrupt on falling edge           |     |     |     |     |     |
|  | 1                             | 0   | Enables interrupt; interrupt on rising edge            |     |     |     |     |     |
|  | 1                             | 1   | Enables interrupt; interrupt on rising or falling edge |     |     |     |     |     |

| Bit Identifier                                    | .7                            | .6  | .5                          | .4  | .3  | .2  | .1  | .0  |
|---|-------------------------------|-----|-----------------------------|-----|-----|-----|-----|-----|
| nRESET Value                                      | 0                             | 0   | 0                           | 0   | 0   | 0   | 0   | 0   |
| Read/Write  | R/W                           | R/W | R/W                         | R/W | R/W | R/W | R/W | R/W |
| Addressing Mode                                   | Register addressing mode only |     |                             |     |     |     |     |     |
| <b>.7– .6 P1.7 Configuration Bits</b>             |                               |     |                             |     |     |     |     |     |
|   | 0                             | 0   | Input mode                  |     |     |     |     |     |
|   | 0                             | 1   | Input mode; pull-up         |     |     |     |     |     |
|   | 1                             | 0   | Alternative function (ADC9) |     |     |     |     |     |
|   | 1                             | 1   | Push-pull output mode       |     |     |     |     |     |
| <b>.5– .4 P1.6 Configuration Bits</b>             |                               |     |                             |     |     |     |     |     |
|   | 0                             | 0   | Input mode                  |     |     |     |     |     |
|   | 0                             | 1   | Input mode; pull-up         |     |     |     |     |     |
|   | 1                             | 0   | Alternative function (ADC8) |     |     |     |     |     |
|   | 1                             | 1   | Push-pull output mode       |     |     |     |     |     |
| <b>.3– .2 P1.5/VLC3 (NOTE) Configuration Bits</b> |                               |     |                             |     |     |     |     |     |
|   | 0                             | 0   | Input mode                  |     |     |     |     |     |
|   | 0                             | 1   | Input mode; pull-up         |     |     |     |     |     |
|   | 1                             | 0   | Not available               |     |     |     |     |     |
|   | 1                             | 1   | Push-pull output mode       |     |     |     |     |     |
| <b>.1– .0 P1.4/VLC2 (NOTE) Configuration Bits</b> |                               |     |                             |     |     |     |     |     |
|   | 0                             | 0   | Input mode                  |     |     |     |     |     |
|   | 0                             | 1   | Input mode; pull-up         |     |     |     |     |     |
|   | 1                             | 0   | Not available               |     |     |     |     |     |
|   | 1                             | 1   | Push-pull output mode       |     |     |     |     |     |

**NOTE:** Refer to LCON Register in LCD chapter 15 for more information.



|                        |  |           |                       |           |           |           |           |           |
|------------------------|--|-----------|-----------------------|-----------|-----------|-----------|-----------|-----------|
| <b>Bit Identifier</b>  | <b>.7</b>                                  | <b>.6</b> | <b>.5</b>             | <b>.4</b> | <b>.3</b> | <b>.2</b> | <b>.1</b> | <b>.0</b> |
| <b>nRESET Value</b>    | 0  | 0         | 0                     | 0         | 0         | 0         | 0         | 0         |
| <b>Read/Write</b>      | R/W  | R/W       | R/W                   | R/W       | R/W       | R/W       | R/W       | R/W       |
| <b>Addressing Mode</b> | Register addressing mode only              |           |                       |           |           |           |           |           |
| <b>.7– .6</b>          | <b>P1.3/VLC1 (NOTE) Configuration Bits</b> |           |                       |           |           |           |           |           |
|                        | 0  | 0         | Input mode            |           |           |           |           |           |
|                        | 0  | 1         | Input mode; pull-up   |           |           |           |           |           |
|                        | 1  | 0         | Not available         |           |           |           |           |           |
|                        | 1  | 1         | Push-pull output mode |           |           |           |           |           |
| <b>.5– .4</b>          | <b>P1.2/VLC0 (NOTE) Configuration Bits</b> |           |                       |           |           |           |           |           |
|                        | 0  | 0         | Input mode            |           |           |           |           |           |
|                        | 0  | 1         | Input mode; pull-up   |           |           |           |           |           |
|                        | 1  | 0         | Not available         |           |           |           |           |           |
|                        | 1  | 1         | Push-pull output mode |           |           |           |           |           |
| <b>.3– .2</b>          | <b>P1.1/CB (NOTE) Configuration Bits</b>   |           |                       |           |           |           |           |           |
|                        | 0  | 0         | Input mode            |           |           |           |           |           |
|                        | 0  | 1         | Input mode; pull-up   |           |           |           |           |           |
|                        | 1  | 0         | Not available         |           |           |           |           |           |
|                        | 1  | 1         | Push-pull output mode |           |           |           |           |           |
| <b>.1– .0</b>          | <b>P1.0/CA (NOTE) Configuration Bits</b>   |           |                       |           |           |           |           |           |
|                        | 0  | 0         | Input mode            |           |           |           |           |           |
|                        | 0  | 1         | Input mode; pull-up   |           |           |           |           |           |
|                        | 1  | 0         | Not available         |           |           |           |           |           |
|                        | 1  | 1         | Push-pull output mode |           |           |           |           |           |

**NOTE:** Refer to LCON register in LCD Chapter 15 for more information.

| Bit Identifier                                  | .7                            | .6  | .5                                | .4  | .3  | .2  | .1  | .0  |
|---|-------------------------------|-----|-----------------------------------|-----|-----|-----|-----|-----|
| nRESET Value                                    | 0                             | 0   | 0                                 | 0   | 0   | 0   | 0   | 0   |
| Read/Write                                      | R/W                           | R/W | R/W                               | R/W | R/W | R/W | R/W | R/W |
| Addressing Mode                                 | Register addressing mode only |     |                                   |     |     |     |     |     |
| <b>.7– .6 P2.7/SEG5/COM7 Configuration Bits</b> |                               |     |                                   |     |     |     |     |     |
|   | 0                             | 0   | Input mode                        |     |     |     |     |     |
|   | 0                             | 1   | Input mode; pull-up               |     |     |     |     |     |
|   | 1                             | 0   | Alternative function (LCD signal) |     |     |     |     |     |
|   | 1                             | 1   | Push-pull output mode             |     |     |     |     |     |
| <b>.5– .4 P2.6/SEG4/COM6 Configuration Bits</b> |                               |     |                                   |     |     |     |     |     |
|   | 0                             | 0   | Input mode                        |     |     |     |     |     |
|   | 0                             | 1   | Input mode; pull-up               |     |     |     |     |     |
|   | 1                             | 0   | Alternative function (LCD signal) |     |     |     |     |     |
|   | 1                             | 1   | Push-pull output mode             |     |     |     |     |     |
| <b>.3– .2 P2.5/SEG3/COM5 Configuration Bits</b> |                               |     |                                   |     |     |     |     |     |
|   | 0                             | 0   | Input mode                        |     |     |     |     |     |
|   | 0                             | 1   | Input mode; pull-up               |     |     |     |     |     |
|   | 1                             | 0   | Alternative function (LCD signal) |     |     |     |     |     |
|   | 1                             | 1   | Push-pull output mode             |     |     |     |     |     |
| <b>.1– .0 P2.4/SEG2/COM4 Configuration Bits</b> |                               |     |                                   |     |     |     |     |     |
|   | 0                             | 0   | Input mode                        |     |     |     |     |     |
|   | 0                             | 1   | Input mode; pull-up               |     |     |     |     |     |
|   | 1                             | 0   | Alternative function (LCD signal) |     |     |     |     |     |
|   | 1                             | 1   | Push-pull output mode             |     |     |     |     |     |

| Bit Identifier                                  | .7                            | .6  | .5                                | .4  | .3  | .2  | .1  | .0  |
|---|-------------------------------|-----|-----------------------------------|-----|-----|-----|-----|-----|
| nRESET Value                                    | 0                             | 0   | 0                                 | 0   | 0   | 0   | 0   | 0   |
| Read/Write                                      | R/W                           | R/W | R/W                               | R/W | R/W | R/W | R/W | R/W |
| Addressing Mode                                 | Register addressing mode only |     |                                   |     |     |     |     |     |
| <b>.7– .6 P2.3/SEG1/COM3 Configuration Bits</b> |                               |     |                                   |     |     |     |     |     |
|   | 0                             | 0   | Input mode                        |     |     |     |     |     |
|   | 0                             | 1   | Input mode; pull-up               |     |     |     |     |     |
|   | 1                             | 0   | Alternative function (LCD signal) |     |     |     |     |     |
|   | 1                             | 1   | Push-pull output mode             |     |     |     |     |     |
| <b>.5– .4 P2.2/SEG0/COM2 Configuration Bits</b> |                               |     |                                   |     |     |     |     |     |
|   | 0                             | 0   | Input mode                        |     |     |     |     |     |
|   | 0                             | 1   | Input mode; pull-up               |     |     |     |     |     |
|   | 1                             | 0   | Alternative function (LCD signal) |     |     |     |     |     |
|   | 1                             | 1   | Push-pull output mode             |     |     |     |     |     |
| <b>.3– .2 P2.1/COM1 Configuration Bits</b>      |                               |     |                                   |     |     |     |     |     |
|   | 0                             | 0   | Input mode                        |     |     |     |     |     |
|   | 0                             | 1   | Input mode; pull-up               |     |     |     |     |     |
|   | 1                             | 0   | Alternative function (LCD signal) |     |     |     |     |     |
|   | 1                             | 1   | Push-pull output mode             |     |     |     |     |     |
| <b>.1– .0 P2.0/COM0 Configuration Bits</b>      |                               |     |                                   |     |     |     |     |     |
|   | 0                             | 0   | Input mode                        |     |     |     |     |     |
|   | 0                             | 1   | Input mode; pull-up               |     |     |     |     |     |
|   | 1                             | 0   | Alternative function (LCD signal) |     |     |     |     |     |
|   | 1                             | 1   | Push-pull output mode             |     |     |     |     |     |

| Bit Identifier  | .7                            | .6  | .5   | .4  | .3  | .2  | .1  | .0  |
|---|-------------------------------|-----|--|-----|-----|-----|-----|-----|
| nRESET Value  | 0                             | 0   | 0  | 0   | 0   | 0   | 0   | 0   |
| Read/Write  | R/W                           | R/W | R/W  | R/W | R/W | R/W | R/W | R/W |
| Addressing Mode   | Register addressing mode only |     |  |     |     |     |     |     |
| <b>.7– .6 P3.7/INT7/T1OUT/T1CAP/SEG13 Configuration Bits</b>    |                               |     |  |     |     |     |     |     |
|   | 0                             | 0   | Schmitt trigger input mode (T1CAP)           |     |     |     |     |     |
|   | 0                             | 1   | Alternative function (T1OUT)                 |     |     |     |     |     |
|   | 1                             | 0   | Alternative function (LCD signal)            |     |     |     |     |     |
|   | 1                             | 1   | Output mode                                  |     |     |     |     |     |
| <b>.5– .4 P3.6/INT6/T1CLK/SEG12/SCL Configuration Bits</b>      |                               |     |  |     |     |     |     |     |
|   | 0                             | 0   | Schmitt trigger input mode (T1CLK)           |     |     |     |     |     |
|   | 0                             | 1   | Alternative function (IIC signal SCL) (NOTE) |     |     |     |     |     |
|   | 1                             | 0   | Alternative function (LCD signal)            |     |     |     |     |     |
|   | 1                             | 1   | Output mode                                  |     |     |     |     |     |
| <b>.3– .2 P3.5/INT5/SDA /SEG11/ T2CLK Configuration Bits</b>    |                               |     |  |     |     |     |     |     |
|   | 0                             | 0   | Schmitt trigger input mode (T2CLK)           |     |     |     |     |     |
|   | 0                             | 1   | Alternative function (IIC signal SDA) (NOTE) |     |     |     |     |     |
|   | 1                             | 0   | Alternative function (LCD signal)            |     |     |     |     |     |
|   | 1                             | 1   | Output mode                                  |     |     |     |     |     |
| <b>.1– .0 P3.4/INT4/ SEG10/ T2OUT/ T2CAP Configuration Bits</b> |                               |     |  |     |     |     |     |     |
|   | 0                             | 0   | Schmitt trigger input mode (T2CAP)           |     |     |     |     |     |
|   | 0                             | 1   | Alternative function (T2OUT)                 |     |     |     |     |     |
|   | 1                             | 0   | Alternative function (LCD signal)            |     |     |     |     |     |
|   | 1                             | 1   | Output mode                                  |     |     |     |     |     |

**NOTE:** If you want to use IIC open drain type, set PNE3.5 and PNE3.6 to "1".

4.1.30 P3CONL-Port 3 Control Register Low Byte (E9H, BANK1)

| Bit Identifier                                   | .7                            | .6  | .5                                | .4  | .3  | .2  | .1  | .0  |
|--|-------------------------------|-----|-----------------------------------|-----|-----|-----|-----|-----|
| nRESET Value                                     | 0                             | 0   | 0                                 | 0   | 0   | 0   | 0   | 0   |
| Read/Write                                       | R/W                           | R/W | R/W                               | R/W | R/W | R/W | R/W | R/W |
| Addressing Mode                                  | Register addressing mode only |     |                                   |     |     |     |     |     |
| <b>.7– .6 P3.3/NSS/SEG9 Configuration Bits</b>   |                               |     |                                   |     |     |     |     |     |
|  | 0                             | 0   | Schmitt trigger input mode        |     |     |     |     |     |
|  | 0                             | 1   | Alternative function (NSS)        |     |     |     |     |     |
|  | 1                             | 0   | Alternative function (LCD signal) |     |     |     |     |     |
|  | 1                             | 1   | Output mode                       |     |     |     |     |     |
| <b>.5– .4 P3.2/ SCK/SEG8 Configuration Bits</b>  |                               |     |                                   |     |     |     |     |     |
|  | 0                             | 0   | Schmitt trigger input mode        |     |     |     |     |     |
|  | 0                             | 1   | Alternative function (SCK)        |     |     |     |     |     |
|  | 1                             | 0   | Alternative function (LCD signal) |     |     |     |     |     |
|  | 1                             | 1   | Output mode                       |     |     |     |     |     |
| <b>.3– .2 P3.1/MOSI/SEG7 Configuration Bits</b>  |                               |     |                                   |     |     |     |     |     |
|  | 0                             | 0   | Schmitt trigger input mode        |     |     |     |     |     |
|  | 0                             | 1   | Alternative function (MOSI)       |     |     |     |     |     |
|  | 1                             | 0   | Alternative function (LCD signal) |     |     |     |     |     |
|  | 1                             | 1   | Output mode                       |     |     |     |     |     |
| <b>.1– .0 P3.0/ MISO/SEG6 Configuration Bits</b> |                               |     |                                   |     |     |     |     |     |
|  | 0                             | 0   | Schmitt trigger input mode        |     |     |     |     |     |
|  | 0                             | 1   | Alternative function (MISO)       |     |     |     |     |     |
|  | 1                             | 0   | Alternative function (LCD signal) |     |     |     |     |     |
|  | 1                             | 1   | Output mode                       |     |     |     |     |     |

4.1.31 P3INT-Port 3 Interrupt Control Register (EBH, BANK1)

| Bit Identifier   | .7                            | .6  | .5   | .4  | .3  | .2  | .1  | .0  |
|--|-------------------------------|-----|--|-----|-----|-----|-----|-----|
| nRESET Value   | 0                             | 0   | 0  | 0   | 0   | 0   | 0   | 0   |
| Read/Write   | R/W                           | R/W | R/W  | R/W | R/W | R/W | R/W | R/W |
| Addressing Mode  | Register addressing mode only |     |  |     |     |     |     |     |
| <b>.7– .6 P3.7 (INT7) External Interrupt Configuration Bit</b> |                               |     |  |     |     |     |     |     |
|  | 0                             | 0   | Disables interrupt                                     |     |     |     |     |     |
|  | 0                             | 1   | Enables interrupt; interrupt on falling edge           |     |     |     |     |     |
|  | 1                             | 0   | Enables interrupt; interrupt on rising edge            |     |     |     |     |     |
|  | 1                             | 1   | Enables interrupt; interrupt on rising or falling edge |     |     |     |     |     |
| <b>.5– .4 P3.6 (INT6) External Interrupt Configuration Bit</b> |                               |     |  |     |     |     |     |     |
|  | 0                             | 0   | Disables interrupt                                     |     |     |     |     |     |
|  | 0                             | 1   | Enables interrupt; interrupt on falling edge           |     |     |     |     |     |
|  | 1                             | 0   | Enables interrupt; interrupt on rising edge            |     |     |     |     |     |
|  | 1                             | 1   | Enables interrupt; interrupt on rising or falling edge |     |     |     |     |     |
| <b>.3– .2 P3.5 (INT5) External Interrupt Configuration Bit</b> |                               |     |  |     |     |     |     |     |
|  | 0                             | 0   | Disables interrupt                                     |     |     |     |     |     |
|  | 0                             | 1   | Enables interrupt; interrupt on falling edge           |     |     |     |     |     |
|  | 1                             | 0   | Enables interrupt; interrupt on rising edge            |     |     |     |     |     |
|  | 1                             | 1   | Enables interrupt; interrupt on rising or falling edge |     |     |     |     |     |
| <b>.1– .0 P3.4 (INT4) External Interrupt Configuration Bit</b> |                               |     |  |     |     |     |     |     |
|  | 0                             | 0   | Disables interrupt                                     |     |     |     |     |     |
|  | 0                             | 1   | Enables interrupt; interrupt on falling edge           |     |     |     |     |     |
|  | 1                             | 0   | Enables interrupt; interrupt on rising edge            |     |     |     |     |     |
|  | 1                             | 1   | Enables interrupt; interrupt on rising or falling edge |     |     |     |     |     |

4.1.32 P3PUR-Port 3 Pull-Up Resistor Enable Register (ECH, BANK1)

| Bit Identifier                            | .7                            | .6                        | .5  | .4  | .3  | .2  | .1  | .0  |
|---|-------------------------------|---------------------------|-----|-----|-----|-----|-----|-----|
| nRESET Value                              | 0                             | 0                         | 0   | 0   | 0   | 0   | 0   | 0   |
| Read/Write                                | R/W                           | R/W                       | R/W | R/W | R/W | R/W | R/W | R/W |
| Addressing Mode                           | Register addressing mode only |                           |     |     |     |     |     |     |
| <b>.7</b>                                 |                               |                           |     |     |     |     |     |     |
| <b>P3.7's Pull-up Resistor Enable Bit</b> |                               |                           |     |     |     |     |     |     |
|   | 0                             | Disables pull-up resistor |     |     |     |     |     |     |
|   | 1                             | Enables pull-up resistor  |     |     |     |     |     |     |
| <b>.6</b>                                 |                               |                           |     |     |     |     |     |     |
| <b>P3.6's Pull-up Resistor Enable Bit</b> |                               |                           |     |     |     |     |     |     |
|   | 0                             | Disables pull-up resistor |     |     |     |     |     |     |
|   | 1                             | Enables pull-up resistor  |     |     |     |     |     |     |
| <b>.5</b>                                 |                               |                           |     |     |     |     |     |     |
| <b>P3.5's Pull-up Resistor Enable Bit</b> |                               |                           |     |     |     |     |     |     |
|   | 0                             | Disables pull-up resistor |     |     |     |     |     |     |
|   | 1                             | Enables pull-up resistor  |     |     |     |     |     |     |
| <b>.4</b>                                 |                               |                           |     |     |     |     |     |     |
| <b>P3.4's Pull-up Resistor Enable Bit</b> |                               |                           |     |     |     |     |     |     |
|   | 0                             | Disables pull-up resistor |     |     |     |     |     |     |
|   | 1                             | Enables pull-up resistor  |     |     |     |     |     |     |
| <b>.3</b>                                 |                               |                           |     |     |     |     |     |     |
| <b>P3.3's Pull-up Resistor Enable Bit</b> |                               |                           |     |     |     |     |     |     |
|   | 0                             | Disables pull-up resistor |     |     |     |     |     |     |
|   | 1                             | Enables pull-up resistor  |     |     |     |     |     |     |
| <b>.2</b>                                 |                               |                           |     |     |     |     |     |     |
| <b>P3.2's Pull-up Resistor Enable Bit</b> |                               |                           |     |     |     |     |     |     |
|   | 0                             | Disables pull-up resistor |     |     |     |     |     |     |
|   | 1                             | Enables pull-up resistor  |     |     |     |     |     |     |
| <b>.1</b>                                 |                               |                           |     |     |     |     |     |     |
| <b>P3.1's Pull-up Resistor Enable Bit</b> |                               |                           |     |     |     |     |     |     |
|   | 0                             | Disables pull-up resistor |     |     |     |     |     |     |
|   | 1                             | Enables pull-up resistor  |     |     |     |     |     |     |
| <b>.0</b>                                 |                               |                           |     |     |     |     |     |     |
| <b>P3.0's Pull-up Resistor Enable Bit</b> |                               |                           |     |     |     |     |     |     |
|   | 0                             | Disables pull-up resistor |     |     |     |     |     |     |
|   | 1                             | Enables pull-up resistor  |     |     |     |     |     |     |



**NOTE:** A pull-up resistor of port 3 is automatically disabled only when the corresponding pin is selected as push-pull output or alternative function



4.1.33 P4CONH-Port 4 Control Register High Byte (EEH, BANK1)

| Bit Identifier                                   | .7                            | .6  | .5                                | .4  | .3  | .2  | .1  | .0  |
|--|-------------------------------|-----|-----------------------------------|-----|-----|-----|-----|-----|
| nRESET Value                                     | 0                             | 0   | 0                                 | 0   | 0   | 0   | 0   | 0   |
| Read/Write                                       | R/W                           | R/W | R/W                               | R/W | R/W | R/W | R/W | R/W |
| Addressing Mode                                  | Register addressing mode only |     |                                   |     |     |     |     |     |
| <b>.7– .6 P4.7/RXD0/SEG21 Configuration Bits</b> |                               |     |                                   |     |     |     |     |     |
|  | 0                             | 0   | Input mode (RXD0)                 |     |     |     |     |     |
|  | 0                             | 1   | Alternative function (RXD0 out)   |     |     |     |     |     |
|  | 1                             | 0   | Alternative function (LCD signal) |     |     |     |     |     |
|  | 1                             | 1   | Output mode                       |     |     |     |     |     |
| <b>.5– .4 P4.6/TXD0/SEG20 Configuration Bits</b> |                               |     |                                   |     |     |     |     |     |
|  | 0                             | 0   | Input mode                        |     |     |     |     |     |
|  | 0                             | 1   | Alternative function (TXD0)       |     |     |     |     |     |
|  | 1                             | 0   | Alternative function (LCD signal) |     |     |     |     |     |
|  | 1                             | 1   | Output mode                       |     |     |     |     |     |
| <b>.3– .2 P4.5/RXD1/SEG19 Configuration Bits</b> |                               |     |                                   |     |     |     |     |     |
|  | 0                             | 0   | Input mode (RXD1)                 |     |     |     |     |     |
|  | 0                             | 1   | Alternative function (RXD1 out)   |     |     |     |     |     |
|  | 1                             | 0   | Alternative function (LCD signal) |     |     |     |     |     |
|  | 1                             | 1   | Output mode                       |     |     |     |     |     |
| <b>.1– .0 P4.4/TXD1/SEG18 Configuration Bits</b> |                               |     |                                   |     |     |     |     |     |
|  | 0                             | 0   | Input mode                        |     |     |     |     |     |
|  | 0                             | 1   | Alternative function (TXD1)       |     |     |     |     |     |
|  | 1                             | 0   | Alternative function (LCD signal) |     |     |     |     |     |
|  | 1                             | 1   | Output mode                       |     |     |     |     |     |

4.1.34 P4CONL-Port 4 Control Register Low Byte (EFH, BANK1)

| Bit Identifier  | .7                            | .6  | .5                                | .4  | .3  | .2  | .1  | .0  |
|---|-------------------------------|-----|-----------------------------------|-----|-----|-----|-----|-----|
| nRESET Value  | 0                             | 0   | 0                                 | 0   | 0   | 0   | 0   | 0   |
| Read/Write  | R/W                           | R/W | R/W                               | R/W | R/W | R/W | R/W | R/W |
| Addressing Mode   | Register addressing mode only |     |                                   |     |     |     |     |     |
| <b>.7– .6 P4.3/TAOUT/TACAP/SEG17 Configuration Bits</b> |                               |     |                                   |     |     |     |     |     |
|   | 0                             | 0   | Input mode (TACAP)                |     |     |     |     |     |
|   | 0                             | 1   | Alternative function (TAOUT)      |     |     |     |     |     |
|   | 1                             | 0   | Alternative function (LCD signal) |     |     |     |     |     |
|   | 1                             | 1   | Output mode                       |     |     |     |     |     |
| <b>.5– .4 P4.2/TACLK/SEG16 Configuration Bits</b>       |                               |     |                                   |     |     |     |     |     |
|   | 0                             | 0   | Input mode (TACLK)                |     |     |     |     |     |
|   | 0                             | 1   | Not available                     |     |     |     |     |     |
|   | 1                             | 0   | Alternative function (LCD signal) |     |     |     |     |     |
|   | 1                             | 1   | Output mode                       |     |     |     |     |     |
| <b>.3– .2 P4.1/TBOUT/SEG15 Configuration Bits</b>       |                               |     |                                   |     |     |     |     |     |
|   | 0                             | 0   | Input mode                        |     |     |     |     |     |
|   | 0                             | 1   | Alternative function (TBOUT)      |     |     |     |     |     |
|   | 1                             | 0   | Alternative function (LCD signal) |     |     |     |     |     |
|   | 1                             | 1   | Output mode                       |     |     |     |     |     |
| <b>.1– .0 P4.0/T0OUT/SEG14 Configuration Bits</b>       |                               |     |                                   |     |     |     |     |     |
|   | 0                             | 0   | Input mode                        |     |     |     |     |     |
|   | 0                             | 1   | Alternative function (T0OUT)      |     |     |     |     |     |
|   | 1                             | 0   | Alternative function (LCD signal) |     |     |     |     |     |
|   | 1                             | 1   | Output mode                       |     |     |     |     |     |

4.1.35 P4PUR-Port 4 Pull-Up Resistor Enable Register (EDH, BANK1)

| Bit Identifier  | .7                            | .6  | .5  | .4  | .3  | .2  | .1  | .0  |
|-----------------|-------------------------------|---|-----|-----|-----|-----|-----|-----|
| nRESET Value    | 0                             | 0   | 0   | 0   | 0   | 0   | 0   | 0   |
| Read/Write      | R/W                           | R/W                                       | R/W | R/W | R/W | R/W | R/W | R/W |
| Addressing Mode | Register addressing mode only |   |     |     |     |     |     |     |
| <b>.7</b>       |                               |   |     |     |     |     |     |     |
|                 |                               | <b>P4.7's Pull-up Resistor Enable Bit</b> |     |     |     |     |     |     |
|                 | 0                             | Disables pull-up resistor                 |     |     |     |     |     |     |
|                 | 1                             | Enables pull-up resistor                  |     |     |     |     |     |     |
| <b>.6</b>       |                               |   |     |     |     |     |     |     |
|                 |                               | <b>P4.6's Pull-up Resistor Enable Bit</b> |     |     |     |     |     |     |
|                 | 0                             | Disables pull-up resistor                 |     |     |     |     |     |     |
|                 | 1                             | Enables pull-up resistor                  |     |     |     |     |     |     |
| <b>.5</b>       |                               |   |     |     |     |     |     |     |
|                 |                               | <b>P4.5's Pull-up Resistor Enable Bit</b> |     |     |     |     |     |     |
|                 | 0                             | Disables pull-up resistor                 |     |     |     |     |     |     |
|                 | 1                             | Enables pull-up resistor                  |     |     |     |     |     |     |
| <b>.4</b>       |                               |   |     |     |     |     |     |     |
|                 |                               | <b>P4.4's Pull-up Resistor Enable Bit</b> |     |     |     |     |     |     |
|                 | 0                             | Disables pull-up resistor                 |     |     |     |     |     |     |
|                 | 1                             | Enables pull-up resistor                  |     |     |     |     |     |     |
| <b>.3</b>       |                               |   |     |     |     |     |     |     |
|                 |                               | <b>P4.3's Pull-up Resistor Enable Bit</b> |     |     |     |     |     |     |
|                 | 0                             | Disables pull-up resistor                 |     |     |     |     |     |     |
|                 | 1                             | Enables pull-up resistor                  |     |     |     |     |     |     |
| <b>.2</b>       |                               |   |     |     |     |     |     |     |
|                 |                               | <b>P4.2's Pull-up Resistor Enable Bit</b> |     |     |     |     |     |     |
|                 | 0                             | Disables pull-up resistor                 |     |     |     |     |     |     |
|                 | 1                             | Enables pull-up resistor                  |     |     |     |     |     |     |
| <b>.1</b>       |                               |   |     |     |     |     |     |     |
|                 |                               | <b>P4.1's Pull-up Resistor Enable Bit</b> |     |     |     |     |     |     |
|                 | 0                             | Disables pull-up resistor                 |     |     |     |     |     |     |
|                 | 1                             | Enables pull-up resistor                  |     |     |     |     |     |     |
| <b>.0</b>       |                               |   |     |     |     |     |     |     |
|                 |                               | <b>P4.0's Pull-up Resistor Enable Bit</b> |     |     |     |     |     |     |
|                 | 0                             | Disables pull-up resistor                 |     |     |     |     |     |     |
|                 | 1                             | Enables pull-up resistor                  |     |     |     |     |     |     |



**NOTE:** A pull-up resistor of port 4 is automatically disabled only when the corresponding pin is selected as push-pull output or alternative function

4.1.36 PNE3-Port 3 N-Channel Open-Drain Mode Register (EAH, BANK1)

| Bit Identifier  | .7                                      | .6                     | .5  | .4  | .3  | .2  | .1  | .0  |
|-----------------|---|------------------------|-----|-----|-----|-----|-----|-----|
| nRESET Value    | 0                                       | 0                      | 0   | 0   | 0   | 0   | 0   | 0   |
| Read/Write      | R/W                                     | R/W                    | R/W | R/W | R/W | R/W | R/W | R/W |
| Addressing Mode | Register addressing mode only           |                        |     |     |     |     |     |     |
| <b>.7</b>       |   |                        |     |     |     |     |     |     |
|                 | <b>P3.7's Output Mode Selection Bit</b> |                        |     |     |     |     |     |     |
|                 | 0                                       | Push-pull output mode  |     |     |     |     |     |     |
|                 | 1                                       | Open-drain output mode |     |     |     |     |     |     |
| <b>.6</b>       |   |                        |     |     |     |     |     |     |
|                 | <b>P3.6's Output Mode Selection Bit</b> |                        |     |     |     |     |     |     |
|                 | 0                                       | Push-pull output mode  |     |     |     |     |     |     |
|                 | 1                                       | Open-drain output mode |     |     |     |     |     |     |
| <b>.5</b>       |   |                        |     |     |     |     |     |     |
|                 | <b>P3.5's Output Mode Selection Bit</b> |                        |     |     |     |     |     |     |
|                 | 0                                       | Push-pull output mode  |     |     |     |     |     |     |
|                 | 1                                       | Open-drain output mode |     |     |     |     |     |     |
| <b>.4</b>       |   |                        |     |     |     |     |     |     |
|                 | <b>P3.4's Output Mode Selection Bit</b> |                        |     |     |     |     |     |     |
|                 | 0                                       | Push-pull output mode  |     |     |     |     |     |     |
|                 | 1                                       | Open-drain output mode |     |     |     |     |     |     |
| <b>.3</b>       |   |                        |     |     |     |     |     |     |
|                 | <b>P3.3's Output Mode Selection Bit</b> |                        |     |     |     |     |     |     |
|                 | 0                                       | Push-pull output mode  |     |     |     |     |     |     |
|                 | 1                                       | Open-drain output mode |     |     |     |     |     |     |
| <b>.2</b>       |   |                        |     |     |     |     |     |     |
|                 | <b>P3.2's Output Mode Selection Bit</b> |                        |     |     |     |     |     |     |
|                 | 0                                       | Push-pull output mode  |     |     |     |     |     |     |
|                 | 1                                       | Open-drain output mode |     |     |     |     |     |     |
| <b>.1</b>       |   |                        |     |     |     |     |     |     |
|                 | <b>P3.1's Output Mode Selection Bit</b> |                        |     |     |     |     |     |     |
|                 | 0                                       | Push-pull output mode  |     |     |     |     |     |     |
|                 | 1                                       | Open-drain output mode |     |     |     |     |     |     |
| <b>.0</b>       |   |                        |     |     |     |     |     |     |
|                 | <b>P3.0's Output Mode Selection Bit</b> |                        |     |     |     |     |     |     |
|                 | 0                                       | Push-pull output mode  |     |     |     |     |     |     |
|                 | 1                                       | Open-drain output mode |     |     |     |     |     |     |

4.1.37 PNE4-Port 4 N-Channel Open-Drain Mode Register (F0H, BANK1)

| Bit Identifier  | .7                                      | .6                     | .5  | .4  | .3  | .2  | .1  | .0  |
|-----------------|---|------------------------|-----|-----|-----|-----|-----|-----|
| nRESET Value    | 0                                       | 0                      | 0   | 0   | 0   | 0   | 0   | 0   |
| Read/Write      | R/W                                     | R/W                    | R/W | R/W | R/W | R/W | R/W | R/W |
| Addressing Mode | Register addressing mode only           |                        |     |     |     |     |     |     |
| <b>.7</b>       |   |                        |     |     |     |     |     |     |
|                 | <b>P4.7's Output Mode Selection Bit</b> |                        |     |     |     |     |     |     |
|                 | 0                                       | Push-pull output mode  |     |     |     |     |     |     |
|                 | 1                                       | Open-drain output mode |     |     |     |     |     |     |
| <b>.6</b>       |   |                        |     |     |     |     |     |     |
|                 | <b>P4.6's Output Mode Selection Bit</b> |                        |     |     |     |     |     |     |
|                 | 0                                       | Push-pull output mode  |     |     |     |     |     |     |
|                 | 1                                       | Open-drain output mode |     |     |     |     |     |     |
| <b>.5</b>       |   |                        |     |     |     |     |     |     |
|                 | <b>P4.5's Output Mode Selection Bit</b> |                        |     |     |     |     |     |     |
|                 | 0                                       | Push-pull output mode  |     |     |     |     |     |     |
|                 | 1                                       | Open-drain output mode |     |     |     |     |     |     |
| <b>.4</b>       |   |                        |     |     |     |     |     |     |
|                 | <b>P4.4's Output Mode Selection Bit</b> |                        |     |     |     |     |     |     |
|                 | 0                                       | Push-pull output mode  |     |     |     |     |     |     |
|                 | 1                                       | Open-drain output mode |     |     |     |     |     |     |
| <b>.3</b>       |   |                        |     |     |     |     |     |     |
|                 | <b>P4.3's Output Mode Selection Bit</b> |                        |     |     |     |     |     |     |
|                 | 0                                       | Push-pull output mode  |     |     |     |     |     |     |
|                 | 1                                       | Open-drain output mode |     |     |     |     |     |     |
| <b>.2</b>       |   |                        |     |     |     |     |     |     |
|                 | <b>P4.2's Output Mode Selection Bit</b> |                        |     |     |     |     |     |     |
|                 | 0                                       | Push-pull output mode  |     |     |     |     |     |     |
|                 | 1                                       | Open-drain output mode |     |     |     |     |     |     |
| <b>.1</b>       |   |                        |     |     |     |     |     |     |
|                 | <b>P4.1's Output Mode Selection Bit</b> |                        |     |     |     |     |     |     |
|                 | 0                                       | Push-pull output mode  |     |     |     |     |     |     |
|                 | 1                                       | Open-drain output mode |     |     |     |     |     |     |
| <b>.0</b>       |   |                        |     |     |     |     |     |     |
|                 | <b>P4.0's Output Mode Selection Bit</b> |                        |     |     |     |     |     |     |
|                 | 0                                       | Push-pull output mode  |     |     |     |     |     |     |
|                 | 1                                       | Open-drain output mode |     |     |     |     |     |     |

| Bit Identifier  | .7  | .6   | .5  | .4  | .3  | .2  | .1  | .0  |
|-----------------|---|--|-----|-----|-----|-----|-----|-----|
| nRESET Value    | 0   | 0  | 0   | 0   | 0   | 0   | 0   | 0   |
| Read/Write      | R/W   | R/W  | R/W | R/W | R/W | R/W | R/W | R/W |
| Addressing Mode | Register addressing mode only                     |  |     |     |     |     |     |     |
| <b>.7</b>       | <b>P3.7 (INT7) External Interrupt Pending Bit</b> |  |     |     |     |     |     |     |
|                 | 0   | Interrupt request is not pending; (when read) pending bit clear when write 0 |     |     |     |     |     |     |
|                 | 1   | Interrupt request is pending (when read)                                     |     |     |     |     |     |     |
| <b>.6</b>       | <b>P3.6 (INT6) External Interrupt Pending Bit</b> |  |     |     |     |     |     |     |
|                 | 0   | Interrupt request is not pending; (when read) pending bit clear when write 0 |     |     |     |     |     |     |
|                 | 1   | Interrupt request is pending (when read)                                     |     |     |     |     |     |     |
| <b>.5</b>       | <b>P3.5 (INT5) External Interrupt Pending Bit</b> |  |     |     |     |     |     |     |
|                 | 0   | Interrupt request is not pending; (when read) pending bit clear when write 0 |     |     |     |     |     |     |
|                 | 1   | Interrupt request is pending (when read)                                     |     |     |     |     |     |     |
| <b>.4</b>       | <b>P3.4 (INT4) External Interrupt Pending Bit</b> |  |     |     |     |     |     |     |
|                 | 0   | Interrupt request is not pending; (when read) pending bit clear when write 0 |     |     |     |     |     |     |
|                 | 1   | Interrupt request is pending (when read)                                     |     |     |     |     |     |     |
| <b>.3</b>       | <b>P0.3 (INT3) External Interrupt Pending Bit</b> |  |     |     |     |     |     |     |
|                 | 0   | Interrupt request is not pending; (when read) pending bit clear when write 0 |     |     |     |     |     |     |
|                 | 1   | Interrupt request is pending (when read)                                     |     |     |     |     |     |     |
| <b>.2</b>       | <b>P0.2 (INT2) External Interrupt Pending Bit</b> |  |     |     |     |     |     |     |
|                 | 0   | Interrupt request is not pending; (when read) pending bit clear when write 0 |     |     |     |     |     |     |
|                 | 1   | Interrupt request is pending (when read)                                     |     |     |     |     |     |     |
| <b>.1</b>       | <b>P0.1 (INT1) External Interrupt Pending Bit</b> |  |     |     |     |     |     |     |
|                 | 0   | Interrupt request is not pending; (when read) pending bit clear when write 0 |     |     |     |     |     |     |
|                 | 1   | Interrupt request is pending (when read)                                     |     |     |     |     |     |     |
| <b>.0</b>       | <b>P0.0 (INT0) External Interrupt Pending Bit</b> |  |     |     |     |     |     |     |
|                 | 0   | Interrupt request is not pending; (when read) pending bit clear when write 0 |     |     |     |     |     |     |
|                 | 1   | Interrupt request is pending (when read)                                     |     |     |     |     |     |     |

| Bit Identifier   | .7                            | .6  | .5  | .4                             | .3                  | .2  | .1  | .0  |
|--|-------------------------------|-----|-----|--------------------------------|---------------------|-----|-----|-----|
| nRESET Value   | 0                             | 0   | 0   | 0                              | 0                   | 0   | 0   | 0   |
| Read/Write   | R/W                           | R/W | R/W | R/W                            | R/W                 | R/W | R/W | R/W |
| Addressing Mode  | Register addressing mode only |     |     |                                |                     |     |     |     |
| <b>.7– .4 Destination Register Page Selection Bits</b> |                               |     |     |                                |                     |     |     |     |
|  | 0                             | 0   | 0   | 0                              | Destination: page 0 |     |     |     |
|  | 0                             | 0   | 0   | 1                              | Destination: page 1 |     |     |     |
|  | 0                             | 0   | 1   | 0                              | Destination: page 2 |     |     |     |
|  | 0                             | 0   | 1   | 1                              | Destination: page 3 |     |     |     |
|  | 0                             | 1   | 0   | 0                              | Destination: page 4 |     |     |     |
|  | 0                             | 1   | 0   | 1                              | Destination: page 5 |     |     |     |
|  | 0                             | 1   | 1   | 0                              | Destination: page 6 |     |     |     |
|  | 0                             | 1   | 1   | 1                              | Destination: page 7 |     |     |     |
|  | 1                             | 0   | 0   | 0                              | Destination: page 8 |     |     |     |
|  | Others                        |     |     | Not used for the S3F8S19/F8S15 |                     |     |     |     |
| <b>.3– .0 Source Register Page Selection Bits</b>      |                               |     |     |                                |                     |     |     |     |
|  | 0                             | 0   | 0   | 0                              | Source: page 0      |     |     |     |
|  | 0                             | 0   | 0   | 1                              | Source: page 1      |     |     |     |
|  | 0                             | 0   | 1   | 0                              | Source: page 2      |     |     |     |
|  | 0                             | 0   | 1   | 1                              | Source: page 2      |     |     |     |
|  | 0                             | 1   | 0   | 0                              | Source: page 4      |     |     |     |
|  | 0                             | 1   | 0   | 1                              | Source: page 5      |     |     |     |
|  | 0                             | 1   | 1   | 0                              | Source: page 6      |     |     |     |
|  | 0                             | 1   | 1   | 1                              | Source: page 7      |     |     |     |
|  | 1                             | 0   | 0   | 0                              | Source: page 8      |     |     |     |
|  | Others                        |     |     | Not used for the S3F8S19/F8S15 |                     |     |     |     |

**NOTE:**

1. In S3F8S19/F8S15 microcontroller, the internal register file is configured as 9 pages (Pages 0-7, 8). The pages 0-7 are used for general purpose register file.
2. /it uses page 8 of S3F8S19/F8S15 for LCD data register (30H–45H).



| Bit Identifier  | .7                                   | .6   | .5 | .4 | .3 | .2  | .1  | .0  |
|-----------------|--------------------------------------|--|----|----|----|-----|-----|-----|
| Read/Write      | –                                    | –  | –  | –  | –  | R/W | R/W | R/W |
| Addressing Mode | Register addressing mode only        |  |    |    |    |     |     |     |
| .7– .3          | Not used for S3F8S19/F8S15           |  |    |    |    |     |     |     |
| .2              | <b>nReset pin Indicating Bit</b>     |  |    |    |    |     |     |     |
|                 | 0                                    | nReset pin does not generate reset (when read) |    |    |    |     |     |     |
|                 | 1                                    | nReset pin generates reset (when it reads)     |    |    |    |     |     |     |
| .1              | <b>Watchdog Reset Indicating Bit</b> |  |    |    |    |     |     |     |
|                 | 0                                    | Watch dog does not generate reset (when read)  |    |    |    |     |     |     |
|                 | 1                                    | Watch dog generates reset (when it reads)      |    |    |    |     |     |     |
| .0              | <b>LVR Indicating Bit</b>            |  |    |    |    |     |     |     |
|                 | 0                                    | LVR does not generate reset (when it reads)    |    |    |    |     |     |     |
|                 | 1                                    | LVR generates reset (when it reads)            |    |    |    |     |     |     |

| State of RESETID Depends on Reset Source |    |    |    |    |    |     |     |     |
|--|----|----|----|----|----|-----|-----|-----|
|  | .7 | .6 | .5 | .4 | .3 | .2  | .1  | .0  |
| LVR                                      | –  | –  | –  | –  | –  | 0   | 0   | 1   |
| WDT, or nReset pin                       | –  | –  | –  | –  | –  | (3) | (3) | (2) |

**NOTE:**

1. To clear an indicating register, write "0" to indicate flag bit. By writing "1" to a reset the indicating flag (RESETID.0-1, RESETID.2) has no effect.
2. Not affected by any other reset.
3. Bits corresponding to sources that are active at the time of reset will be set.



| Bit Identifier                          | .7                            | .6                 | .5  | .4  | .3  | .2  | .1  | .0  |
|---|-------------------------------|--------------------|-----|-----|-----|-----|-----|-----|
| nRESET Value                            | 0                             | 1                  | 0   | 0   | 0   | 0   | 0   | 0   |
| Read/Write                              | R/W                           | R/W                | R/W | R/W | R/W | R/W | R/W | R/W |
| Addressing Mode                         | Register addressing mode only |                    |     |     |     |     |     |     |
| <b>.7</b>                               |                               |                    |     |     |     |     |     |     |
| <b>Ring Oscillator (OSC) Enable Bit</b> |                               |                    |     |     |     |     |     |     |
|   | 0                             | Disables Ring OSC. |     |     |     |     |     |     |
|   | 1                             | Enables Ring OSC.  |     |     |     |     |     |     |
| <b>.6– .0</b>                           |                               |                    |     |     |     |     |     |     |
| <b>Not Used.</b>                        |                               |                    |     |     |     |     |     |     |

| Bit Identifier  | .7  | .6  | .5  | .4  | .3  | .2 | .1 | .0 |
|-----------------|---|-----|-----|-----|-----|----|----|----|
| nRESET Value    | 1   | 1   | 0   | 0   | 0   | –  | –  | –  |
| Read/Write      | R/W   | R/W | R/W | R/W | R/W | –  | –  | –  |
| Addressing Mode | Register addressing only  |     |     |     |     |    |    |    |
| <b>.7– .3</b>   | <b>Register Pointer 0 Address Value</b>   |     |     |     |     |    |    |    |
|                 | <p>Register pointer 0 can independently point to one of the 256-byte working register areas in the register file.</p> <p>By using the register pointers RP0 and RP1, you can select two 8-byte register slices at a time as active working register space. After a reset, RP0 points to address C0H in register set 1 by selecting the 8-byte working register slice C0H–C7H.</p> |     |     |     |     |    |    |    |
| <b>.2– .0</b>   | <b>Not used for the S3F8S19/F8S15</b>   |     |     |     |     |    |    |    |

#### 4.1.43 RP1-Register Pointer 1 (D7H, SET1)

| Bit Identifier  | .7  | .6  | .5  | .4  | .3  | .2 | .1 | .0 |
|-----------------|---|-----|-----|-----|-----|----|----|----|
| nRESET Value    | 1   | 1   | 0   | 0   | 1   | –  | –  | –  |
| Read/Write      | R/W   | R/W | R/W | R/W | R/W | –  | –  | –  |
| Addressing Mode | Register addressing only  |     |     |     |     |    |    |    |
| <b>.7– .3</b>   | <b>Register Pointer 1 Address Value</b>   |     |     |     |     |    |    |    |
|                 | <p>Register pointer 1 can independently point to one of the 256-byte working register areas in the register file.</p> <p>By using the register pointers RP0 and RP1, you can select two 8-byte register slices at a time as active working register space. After a reset, RP1 points to address C8H in register set 1 by selecting the 8-byte working register slice C8H–CFH.</p> |     |     |     |     |    |    |    |
| <b>.2– .0</b>   | <b>Not used for the S3F8S19/F8S15</b>   |     |     |     |     |    |    |    |

| Bit Identifier   | .7                       | .6  | .5  | .4  | .3  | .2  | .1  | .0  |
|--|--------------------------|-----|-----|-----|-----|-----|-----|-----|
| nRESET Value   | x                        | x   | x   | x   | x   | x   | x   | x   |
| Read/Write   | R/W                      | R/W | R/W | R/W | R/W | R/W | R/W | R/W |
| Addressing Mode  | Register addressing only |     |     |     |     |     |     |     |
| <b>.7– .0</b>  |                          |     |     |     |     |     |     |     |
| <b>Stack Pointer Address (High Byte)</b>   |                          |     |     |     |     |     |     |     |
| The high-byte stack pointer value is the upper eight bits of the 16-bit stack pointer address (SP15–SP8). The lower byte of the stack pointer value is located in register SPL (D9H). The SP value is undefined following a reset. |                          |     |     |     |     |     |     |     |

#### 4.1.45 SPL-Stack Pointer Low Byte (D9H, SET1)

| Bit Identifier   | .7                       | .6  | .5  | .4  | .3  | .2  | .1  | .0  |
|--|--------------------------|-----|-----|-----|-----|-----|-----|-----|
| nRESET Value   | x                        | x   | x   | x   | x   | x   | x   | x   |
| Read/Write   | R/W                      | R/W | R/W | R/W | R/W | R/W | R/W | R/W |
| Addressing Mode  | Register addressing only |     |     |     |     |     |     |     |
| <b>.7– .0</b>  |                          |     |     |     |     |     |     |     |
| <b>Stack Pointer Address (Low Byte)</b>  |                          |     |     |     |     |     |     |     |
| The low-byte stack pointer value is the lower eight bits of the 16-bit stack pointer address (SP7–SP0). The upper byte of the stack pointer value is located in register SPH (D8H). The SP value is undefined following a reset. |                          |     |     |     |     |     |     |     |

| Bit Identifier | .7  | .6                                  | .5       | .4  | .3  | .2  | .1  | .0  |
|----------------|---|-------------------------------------|----------|-----|-----|-----|-----|-----|
| RESET Value    | 0   | 0                                   | 0        | 0   | 0   | 0   | 0   | 0   |
| Read/Write     | R/W   | R/W                                 | R/W      | R/W | R/W | R/W | R/W | R/W |
| <b>.7</b>      | <b>Serial Peripheral Interface (SPI) Interrupt Enable/Disable Bit</b> |                                     |          |     |     |     |     |     |
|                | 0   | Disables SPI Interrupt              |          |     |     |     |     |     |
|                | 1   | Enables SPI Interrupt               |          |     |     |     |     |     |
| <b>.6</b>      | <b>SPI Enable Bit</b>   |                                     |          |     |     |     |     |     |
|                | 0   | Disables SPI                        |          |     |     |     |     |     |
|                | 1   | Enables SPI                         |          |     |     |     |     |     |
| <b>.5</b>      | <b>Data Order Selection Bit</b>                                       |                                     |          |     |     |     |     |     |
|                | 0   | Least Significant Bit (LSB) First   |          |     |     |     |     |     |
|                | 1   | Most Significant Bit (MSB) First    |          |     |     |     |     |     |
| <b>.4</b>      | <b>Master/Slave Mode Selection Bit</b>                                |                                     |          |     |     |     |     |     |
|                | 0   | Slave Mode                          |          |     |     |     |     |     |
|                | 1   | Master Mode                         |          |     |     |     |     |     |
| <b>.3</b>      | <b>Clock Polarity Bit</b>   |                                     |          |     |     |     |     |     |
|                | 0   | Clock Low when idle                 |          |     |     |     |     |     |
|                | 1   | Clock High when idle                |          |     |     |     |     |     |
| <b>.2</b>      | <b>Clock Phase Bit</b>  |                                     |          |     |     |     |     |     |
|                | 0   | Sample on the leading edge of SPCK  |          |     |     |     |     |     |
|                | 1   | Sample on the trailing edge of SPCK |          |     |     |     |     |     |
| <b>.1– .0</b>  | <b>SPCK Rate Selection Bit</b>  |                                     |          |     |     |     |     |     |
|                | 0   | 0                                   | fosc/4   |     |     |     |     |     |
|                | 0   | 1                                   | fosc/16  |     |     |     |     |     |
|                | 1   | 0                                   | fosc/64  |     |     |     |     |     |
|                | 1   | 1                                   | fosc/256 |     |     |     |     |     |

| Bit Identifier                    | .7 | .6                         | .5 | .4 | .3 | .2 | .1 | .0  |
|-----------------------------------|----|----------------------------|----|----|----|----|----|-----|
| RESET Value                       | 0  | 0                          | 0  | –  | –  | –  | –  | 0   |
| Read/Write                        | R  | R                          | R  | –  | –  | –  | –  | R/W |
| <b>.7</b>                         |    |                            |    |    |    |    |    |     |
| <b>SPI Interrupt Pending Bit</b>  |    |                            |    |    |    |    |    |     |
|                                   | 0  | No pending                 |    |    |    |    |    |     |
|                                   | 1  | Interrupt pending          |    |    |    |    |    |     |
| <b>.6</b>                         |    |                            |    |    |    |    |    |     |
| <b>Write Collision Bit</b>        |    |                            |    |    |    |    |    |     |
|                                   | 0  | No write collision         |    |    |    |    |    |     |
|                                   | 1  | Write collision            |    |    |    |    |    |     |
| <b>.5</b>                         |    |                            |    |    |    |    |    |     |
| <b>Mode Fault Bit</b>             |    |                            |    |    |    |    |    |     |
|                                   | 0  | No Mode fault              |    |    |    |    |    |     |
|                                   | 1  | Mode fault                 |    |    |    |    |    |     |
| <b>.4– .1</b>                     |    |                            |    |    |    |    |    |     |
| <b>Not used for S3F8S19/F8S15</b> |    |                            |    |    |    |    |    |     |
|                                   | 0  | Slave Mode                 |    |    |    |    |    |     |
|                                   | 1  | Master Mode                |    |    |    |    |    |     |
| <b>.0</b>                         |    |                            |    |    |    |    |    |     |
| <b>Double SPI Speed Bit</b>       |    |                            |    |    |    |    |    |     |
|                                   | 0  | Single                     |    |    |    |    |    |     |
|                                   | 1  | Double when in Master Mode |    |    |    |    |    |     |

#### 4.1.48 STPCON-STOP Mode Control Register (FBH, BANK1)

| Bit Identifier          | .7          | .6  | .5  | .4                        | .3  | .2  | .1  | .0  |
|-------------------------|-------------|-----|-----|---------------------------|-----|-----|-----|-----|
| RESET Value             | 0           | 0   | 0   | 0                         | 0   | 0   | 0   | 0   |
| Read/Write              | R/W         | R/W | R/W | R/W                       | R/W | R/W | R/W | R/W |
| <b>.7– .0</b>           |             |     |     |                           |     |     |     |     |
| <b>Stop Control Bit</b> |             |     |     |                           |     |     |     |     |
|                         | 10100101    |     |     | Enables STOP instruction  |     |     |     |     |
|                         | Other value |     |     | Disables STOP instruction |     |     |     |     |

**NOTE:**

1. Before executing the STOP instruction, set this STPCON register as "10100101b".
2. When STOPCON register is not set to #0A5H value, if you use STOP instruction, PC is changed to reset address.

| Bit Identifier                                     | .7  | .6                          | .5  | .4  | .3  | .2  | .1  | .0  |
|--|-----|-----------------------------|-----|-----|-----|-----|-----|-----|
| RESET Value  | 0   | –                           | 0   | –   | 0   | 0   | 0   | 0   |
| Read/Write   | R/W | R/W                         | R/W | R/W | R/W | R/W | R/W | R/W |
| <b>.7</b>  |     |                             |     |     |     |     |     |     |
| <b>STOP Wake-up Timer Enable bit</b>               |     |                             |     |     |     |     |     |     |
|  | 0   | Disables STOP Wake-up Timer |     |     |     |     |     |     |
|  | 1   | Enables STOP Wake-up Timer  |     |     |     |     |     |     |
| <b>.6</b>  |     |                             |     |     |     |     |     |     |
| <b>Not used</b>                                    |     |                             |     |     |     |     |     |     |
| <b>.5</b>  |     |                             |     |     |     |     |     |     |
| <b>STOP Wake-up Timer Interrupt Enable bit</b>     |     |                             |     |     |     |     |     |     |
|  | 0   | Disables Interrupt          |     |     |     |     |     |     |
|  | 1   | Enables Interrupt           |     |     |     |     |     |     |
| <b>.4</b>  |     |                             |     |     |     |     |     |     |
| <b>Not used</b>                                    |     |                             |     |     |     |     |     |     |
| <b>.3– .0</b>                                      |     |                             |     |     |     |     |     |     |
| <b>STOP Wake-up Timer pre-scalar bits (SWTPSB)</b> |     |                             |     |     |     |     |     |     |
| $SWTCLK = F_{CLK} / (2^{SWTPSB[3-0]})$             |     |                             |     |     |     |     |     |     |

**NOTE:**

1. Prescaler values (SWTPSB) higher than 12 are NOT valid.
2. Retain bits .6 and .4 as default value "0".

| Bit Identifier  | .7   | .6                                 | .5 | .4   | .3  | .2  | .1  | .0  |
|-----------------|--|------------------------------------|----|------|-----|-----|-----|-----|
| nRESET Value    | –  | –                                  | –  | x    | x   | x   | 0   | 0   |
| Read/Write      | –  | –                                  | –  | R/W  | R/W | R/W | R/W | R/W |
| Addressing Mode | Register addressing mode only                      |                                    |    |      |     |     |     |     |
| .7– .5          | Not used for the S3F8S19/F8S15                     |                                    |    |      |     |     |     |     |
| .4– .2          | Fast Interrupt Level Selection Bits <sup>(1)</sup> |                                    |    |      |     |     |     |     |
|                 | 0  | 0                                  | 0  | IRQ0 |     |     |     |     |
|                 | 0  | 0                                  | 1  | IRQ1 |     |     |     |     |
|                 | 0  | 1                                  | 0  | IRQ2 |     |     |     |     |
|                 | 0  | 1                                  | 1  | IRQ3 |     |     |     |     |
|                 | 1  | 0                                  | 0  | IRQ4 |     |     |     |     |
|                 | 1  | 0                                  | 1  | IRQ5 |     |     |     |     |
|                 | 1  | 1                                  | 0  | IRQ6 |     |     |     |     |
|                 | 1  | 1                                  | 1  | IRQ7 |     |     |     |     |
| .1              | Fast Interrupt Enable Bit <sup>(2)</sup>           |                                    |    |      |     |     |     |     |
|                 | 0  | Disables fast interrupt processing |    |      |     |     |     |     |
|                 | 1  | Enables fast interrupt processing  |    |      |     |     |     |     |
| .0              | Global Interrupt Enable Bit <sup>(3)</sup>         |                                    |    |      |     |     |     |     |
|                 | 0  | Disables all interrupt processing  |    |      |     |     |     |     |
|                 | 1  | Enables all interrupt processing   |    |      |     |     |     |     |

**NOTE:**

1. You can select only one interrupt level at a time for fast interrupt processing.
2. Setting SYM.1 to "1" enables fast interrupt processing for the interrupt level that SYM.2-SYM.4 currently selects.
3. After a reset, enable global interrupt processing by executing an EI instruction (not by writing a "1" to SYM.0).



| Bit Identifier | .7  | .6   | .5  | .4  | .3  | .2  | .1  | .0  |
|----------------|---|--|---|-----|-----|-----|-----|-----|
| RESET Value    | 0   | 0  | 0   | 0   | 0   | 0   | 0   | 0   |
| Read/Write     | R/W   | R/W  | R/W   | R/W | R/W | R/W | R/W | R/W |
| <b>.7– .6</b>  | <b>Timer A Operating Mode Selection Bits</b>      |  |   |     |     |     |     |     |
|                | 0   | 0  | Interval mode (TAOUT mode)  |     |     |     |     |     |
|                | 0   | 1  | Capture mode (capture on rising edge, counter running, Overflow (OVF) occurs) |     |     |     |     |     |
|                | 1   | 0  | Capture mode (capture on falling edge, counter running, OVF occurs)           |     |     |     |     |     |
|                | 1   | 1  | PWM mode (OVF interrupt can occur)  |     |     |     |     |     |
| <b>.5</b>      | <b>Timer A Counter Clear Bit</b>                  |  |   |     |     |     |     |     |
|                | 0   | No effect  |   |     |     |     |     |     |
|                | 1   | Clears the timer A counter (After clearing, returns to zero) |   |     |     |     |     |     |
| <b>.4</b>      | <b>Timer A Start/Stop Bit</b>                     |  |   |     |     |     |     |     |
|                | 0   | Stops Timer A  |   |     |     |     |     |     |
|                | 1   | Starts Timer A   |   |     |     |     |     |     |
| <b>.3</b>      | <b>Timer A Match/Capture Interrupt Enable Bit</b> |  |   |     |     |     |     |     |
|                | 0   | Disables interrupt   |   |     |     |     |     |     |
|                | 1   | Enables interrupt  |   |     |     |     |     |     |
| <b>.2</b>      | <b>Timer A Overflow Interrupt Enable Bit</b>      |  |   |     |     |     |     |     |
|                | 0   | Disables interrupt   |   |     |     |     |     |     |
|                | 1   | Enables interrupt  |   |     |     |     |     |     |
| <b>.1</b>      | <b>Timer A Match Interrupt pending Bit</b>        |  |   |     |     |     |     |     |
|                | 0   | No interrupt pending (Clears pending bit when write)         |   |     |     |     |     |     |
|                | 1   | Interrupt pending  |   |     |     |     |     |     |
| <b>.0</b>      | <b>Timer A Overflow Interrupt pending Bit</b>     |  |   |     |     |     |     |     |
|                | 0   | No interrupt pending (Clears pending bit when write)         |   |     |     |     |     |     |
|                | 1   | Interrupt pending  |   |     |     |     |     |     |

| Bit Identifier   | .7  | .6                               | .5 | .4 | .3  | .2  | .1  | .0  |
|--|-----|----------------------------------|----|----|-----|-----|-----|-----|
| RESET Value  | 0   | –                                | –  | –  | 0   | 0   | 0   | 0   |
| Read/Write   | R/W | –                                | –  | –  | R/W | R/W | R/W | R/W |
| <b>.7</b>  |     |                                  |    |    |     |     |     |     |
| <b>Timer A clock source selection</b>  |     |                                  |    |    |     |     |     |     |
|  | 0   | Internal clock source            |    |    |     |     |     |     |
|  | 1   | External clock source from TACLK |    |    |     |     |     |     |
| <b>.6– .5</b>  |     |                                  |    |    |     |     |     |     |
| <b>Not used for S3F8S19/F8S15</b>  |     |                                  |    |    |     |     |     |     |
| <b>.3– .0</b>  |     |                                  |    |    |     |     |     |     |
| <b>Timer A pre-scalar bits</b>   |     |                                  |    |    |     |     |     |     |
| TAPS = TA clock/(2 <sup>TAPS[3-0]</sup> ) Pre-scalar values higher than 12 are invalid |     |                                  |    |    |     |     |     |     |

| Bit Identifier                                      | .7                            | .6  | .5   | .4  | .3  | .2  | .1  | .0  |
|---|-------------------------------|---|--|-----|-----|-----|-----|-----|
| nRESET Value  | 0                             | 0   | 0  | 0   | 0   | 0   | 0   | 0   |
| Read/Write  | R/W                           | R/W   | R/W  | R/W | R/W | R/W | R/W | R/W |
| Addressing Mode                                     | Register addressing mode only |   |  |     |     |     |     |     |
| <b>.7– .5</b> Not used for S3F8S19/F8S15            |                               |   |  |     |     |     |     |     |
| <b>.4– .3</b> Timer B Interrupt Time Selection Bits |                               |   |  |     |     |     |     |     |
|   | 0                             | 0   | Generates after it borrows data0           |     |     |     |     |     |
|   | 0                             | 1   | Generates after it borrows data1           |     |     |     |     |     |
|   | 1                             | 0   | Generates after it borrows data0 and data1 |     |     |     |     |     |
|   | 1                             | 1   | Not available                              |     |     |     |     |     |
| <b>.2</b> Timer B Start/Stop Bit                    |                               |   |  |     |     |     |     |     |
|   | 0                             | Disables timer B  |  |     |     |     |     |     |
|   | 1                             | Enables timer B   |  |     |     |     |     |     |
| <b>.1</b> Timer B Mode Selection Bit                |                               |   |  |     |     |     |     |     |
|   | 0                             | One-shot mode   |  |     |     |     |     |     |
|   | 1                             | Repeat mode   |  |     |     |     |     |     |
| <b>.0</b> Timer B Output Flip-flop Control Bit      |                               |   |  |     |     |     |     |     |
|   | 0                             | TBOF is low (TBPWM: low level for data0, high level for data1)  |  |     |     |     |     |     |
|   | 1                             | TBOF is high (TBPWM: high level for data0, low level for data1) |  |     |     |     |     |     |

| Bit Identifier   | .7                            | .6  | .5   | .4  | .3  | .2  | .1  | .0  |
|--|-------------------------------|---|--|-----|-----|-----|-----|-----|
| RESET Value  | 0                             | 0   | 0  | 0   | 0   | 0   | 0   | 0   |
| Read/Write   | R/W                           | R/W                                       | R/W  | R/W | R/W | R/W | R/W | R/W |
| Addressing Mode  | Register addressing mode only |   |  |     |     |     |     |     |
| <b>.7 – .6 Emergency detection pin selection bits: ( rising edge)</b>                                  |                               |   |  |     |     |     |     |     |
|  | 0                             | 0   | Generates after it borrows data0           |     |     |     |     |     |
|  | 0                             | 1   | Generates after it borrows data1           |     |     |     |     |     |
|  | 1                             | 0   | Generates after it borrows data0 and data1 |     |     |     |     |     |
|  | 1                             | 1   | Not available                              |     |     |     |     |     |
| <b>.5– .4 Trigger source selection bits:</b>   |                               |   |  |     |     |     |     |     |
|  | 0                             | 0   | P00  |     |     |     |     |     |
|  | 0                             | 1   | P01  |     |     |     |     |     |
|  | 1                             | 0   | P02  |     |     |     |     |     |
|  | 1                             | 1   | P03  |     |     |     |     |     |
| <b>.3– .2 INTX pin valid edge selection Bits:</b>  |                               |   |  |     |     |     |     |     |
|  | 0                             | 0   | Falling edge                               |     |     |     |     |     |
|  | 0                             | 1   | Rising edge                                |     |     |     |     |     |
|  | 1                             | X   | Both falling and rising edge               |     |     |     |     |     |
| <b>.1 Timer B trigger control by H/W or S/W:</b>   |                               |   |  |     |     |     |     |     |
|  | 0                             | Hardware control (external input trigger) |  |     |     |     |     |     |
|  | 1                             | Software control (internal trigger)       |  |     |     |     |     |     |
| <b>.0 Timer B trigger control by software:<br/>(write only, automatically cleared after write "1")</b> |                               |   |  |     |     |     |     |     |
|  | 0                             | Does not trigger one-shot pulse           |  |     |     |     |     |     |
|  | 1                             | Triggers one-shot pulse                   |  |     |     |     |     |     |

| Bit Identifier                                | .7  | .6  | .5                                 | .4  | .3  | .2  | .1  | .0  |
|---|-----|---|------------------------------------|-----|-----|-----|-----|-----|
| RESET Value                                   | 0   | 0   | 0                                  | 0   | 0   | 0   | 0   | 0   |
| Read/Write                                    | R/W | R/W   | R/W                                | R/W | R/W | R/W | R/W | R/W |
| <b>.7– .6</b>                                 |     |   |                                    |     |     |     |     |     |
| <b>Timer 0 Operating Mode Selection Bits</b>  |     |   |                                    |     |     |     |     |     |
|   | 0   | 0   | Interval mode (TAOUT mode)         |     |     |     |     |     |
|   | 0   | 1   | Not used for S3F8S19/F8S15         |     |     |     |     |     |
|   | 1   | 0   | Not used for S3F8S19/F8S15         |     |     |     |     |     |
|   | 1   | 1   | PWM mode (OVF interrupt can occur) |     |     |     |     |     |
| <b>.5</b>                                     |     |   |                                    |     |     |     |     |     |
| <b>Timer 0 Counter Clear Bit</b>              |     |   |                                    |     |     |     |     |     |
|   | 0   | No effect   |                                    |     |     |     |     |     |
|   | 1   | Clears the timer A counter (After clearing, return to zero) |                                    |     |     |     |     |     |
| <b>.4</b>                                     |     |   |                                    |     |     |     |     |     |
| <b>Timer 0 Start/Stop Bit</b>                 |     |   |                                    |     |     |     |     |     |
|   | 0   | Stops Timer A   |                                    |     |     |     |     |     |
|   | 1   | Starts Timer A  |                                    |     |     |     |     |     |
| <b>.3</b>                                     |     |   |                                    |     |     |     |     |     |
| <b>Timer 0 Match Interrupt Enable Bit</b>     |     |   |                                    |     |     |     |     |     |
|   | 0   | Disables interrupt  |                                    |     |     |     |     |     |
|   | 1   | Enables interrupt   |                                    |     |     |     |     |     |
| <b>.2</b>                                     |     |   |                                    |     |     |     |     |     |
| <b>Timer 0 Overflow Interrupt Enable Bit</b>  |     |   |                                    |     |     |     |     |     |
|   | 0   | Disables interrupt  |                                    |     |     |     |     |     |
|   | 1   | Enables interrupt   |                                    |     |     |     |     |     |
| <b>.1</b>                                     |     |   |                                    |     |     |     |     |     |
| <b>Timer 0 Match Interrupt Pending Bit</b>    |     |   |                                    |     |     |     |     |     |
|   | 0   | No interrupt pending (Clears pending bit when write)        |                                    |     |     |     |     |     |
|   | 1   | Interrupt pending   |                                    |     |     |     |     |     |
| <b>.0</b>                                     |     |   |                                    |     |     |     |     |     |
| <b>Timer 0 Overflow Interrupt Pending Bit</b> |     |   |                                    |     |     |     |     |     |
|   | 0   | No interrupt pending (Clears pending bit when write)        |                                    |     |     |     |     |     |
|   | 1   | Interrupt pending   |                                    |     |     |     |     |     |



| Bit Identifier   | .7 | .6 | .5 | .4 | .3  | .2  | .1  | .0  |
|--|----|----|----|----|-----|-----|-----|-----|
| RESET Value  | –  | –  | –  | –  | 0   | 0   | 0   | 0   |
| Read/Write   | –  | –  | –  | –  | R/W | R/W | R/W | R/W |
| <b>.7– .5</b> Not used for S3F8S19/F8S15   |    |    |    |    |     |     |     |     |
| <b>.3– .0</b> Timer 0 pre-scalar bits  |    |    |    |    |     |     |     |     |
| T0PS = T0 clock/(2 <sup>T0PS[3-0]</sup> ) Pre-scalar values higher than 12 are invalid |    |    |    |    |     |     |     |     |

| Bit Identifier | .7  | .6   | .5  | .4  | .3  | .2  | .1  | .0  |
|----------------|---|--|---|-----|-----|-----|-----|-----|
| RESET Value    | 0   | 0  | 0   | 0   | 0   | 0   | 0   | 0   |
| Read/Write     | R/W   | R/W  | R/W   | R/W | R/W | R/W | R/W | R/W |
| <b>.7– .6</b>  | <b>Timer 1 Operating Mode Selection Bits</b>      |  |   |     |     |     |     |     |
|                | 0   | 0  | Interval mode (T1OUT mode)  |     |     |     |     |     |
|                | 0   | 1  | Capture mode (capture on rising edge, counter running, OVF occurs)  |     |     |     |     |     |
|                | 1   | 0  | Capture mode (capture on falling edge, counter running, OVF occurs) |     |     |     |     |     |
|                | 1   | 1  | PWM mode (OVF interrupt can occur)                                  |     |     |     |     |     |
| <b>.5</b>      | <b>Timer 1 Counter Clear Bit</b>                  |  |   |     |     |     |     |     |
|                | 0   | No effect  |   |     |     |     |     |     |
|                | 1   | Clears the timer A counter (After clearing, returns to zero) |   |     |     |     |     |     |
| <b>.4</b>      | <b>Timer 1 Start/Stop Bit</b>                     |  |   |     |     |     |     |     |
|                | 0   | Stops Timer 1  |   |     |     |     |     |     |
|                | 1   | Starts Timer 1   |   |     |     |     |     |     |
| <b>.3</b>      | <b>Timer 1 Match/Capture Interrupt Enable Bit</b> |  |   |     |     |     |     |     |
|                | 0   | Disables interrupt   |   |     |     |     |     |     |
|                | 1   | Enables interrupt  |   |     |     |     |     |     |
| <b>.2</b>      | <b>Timer 1 Overflow Interrupt Enable Bit</b>      |  |   |     |     |     |     |     |
|                | 0   | Disables interrupt   |   |     |     |     |     |     |
|                | 1   | Enables interrupt  |   |     |     |     |     |     |
| <b>.1</b>      | <b>Timer 1 Match Interrupt Pending Bit</b>        |  |   |     |     |     |     |     |
|                | 0   | No interrupt pending (Clears pending bit when write)         |   |     |     |     |     |     |
|                | 1   | Interrupt pending  |   |     |     |     |     |     |
| <b>.0</b>      | <b>Timer 1 Overflow Interrupt Pending Bit</b>     |  |   |     |     |     |     |     |
|                | 0   | No interrupt pending (Clears pending bit when write)         |   |     |     |     |     |     |
|                | 1   | Interrupt pending  |   |     |     |     |     |     |

| Bit Identifier   | .7  | .6                               | .5 | .4 | .3  | .2  | .1  | .0  |
|--|-----|----------------------------------|----|----|-----|-----|-----|-----|
| RESET Value  | 0   | –                                | –  | –  | 0   | 0   | 0   | 0   |
| Read/Write   | R/W | –                                | –  | –  | R/W | R/W | R/W | R/W |
| <b>.7</b>  |     |                                  |    |    |     |     |     |     |
| <b>Timer 1 clock source selection</b>  |     |                                  |    |    |     |     |     |     |
|  | 0   | Internal clock source            |    |    |     |     |     |     |
|  | 1   | External clock source from T1CLK |    |    |     |     |     |     |
| <b>.6– .5</b>  |     |                                  |    |    |     |     |     |     |
| <b>Not used for S3F8S19/F8S15</b>  |     |                                  |    |    |     |     |     |     |
| <b>.3– .0</b>  |     |                                  |    |    |     |     |     |     |
| <b>Timer 1 pre-scalar bits</b>   |     |                                  |    |    |     |     |     |     |
| T1PS = T1 clock/(2 <sup>T1PS[3-0]</sup> ) Pre-scalar values higher than 12 are invalid |     |                                  |    |    |     |     |     |     |



| Bit Identifier | .7  | .6   | .5  | .4  | .3  | .2  | .1  | .0  |
|----------------|---|--|---|-----|-----|-----|-----|-----|
| RESET Value    | 0   | 0  | 0   | 0   | 0   | 0   | 0   | 0   |
| Read/Write     | R/W   | R/W  | R/W   | R/W | R/W | R/W | R/W | R/W |
| <b>.7– .6</b>  | <b>Timer 2 Operating Mode Selection Bits</b>      |  |   |     |     |     |     |     |
|                | 0   | 0  | Interval mode (T2OUT mode)  |     |     |     |     |     |
|                | 0   | 1  | Capture mode (capture on rising edge, counter running, OVF occurs)  |     |     |     |     |     |
|                | 1   | 0  | Capture mode (capture on falling edge, counter running, OVF occurs) |     |     |     |     |     |
|                | 1   | 1  | PWM mode (OVF interrupt can occur)                                  |     |     |     |     |     |
| <b>.5</b>      | <b>Timer 2 Counter Clear Bit</b>                  |  |   |     |     |     |     |     |
|                | 0   | No effect  |   |     |     |     |     |     |
|                | 1   | Clears the timer A counter (After clearing, returns to zero) |   |     |     |     |     |     |
| <b>.4</b>      | <b>Timer 2 Start/Stop Bit</b>                     |  |   |     |     |     |     |     |
|                | 0   | Stops Timer 1  |   |     |     |     |     |     |
|                | 1   | Starts Timer 1   |   |     |     |     |     |     |
| <b>.3</b>      | <b>Timer 2 Match/Capture Interrupt Enable Bit</b> |  |   |     |     |     |     |     |
|                | 0   | Disables interrupt   |   |     |     |     |     |     |
|                | 1   | Enables interrupt  |   |     |     |     |     |     |
| <b>.2</b>      | <b>Timer 2 Overflow Interrupt Enable Bit</b>      |  |   |     |     |     |     |     |
|                | 0   | Disables interrupt   |   |     |     |     |     |     |
|                | 1   | Enables interrupt  |   |     |     |     |     |     |
| <b>.1</b>      | <b>Timer 2 Match Interrupt pending Bit</b>        |  |   |     |     |     |     |     |
|                | 0   | No interrupt pending (Clears pending bit when write)         |   |     |     |     |     |     |
|                | 1   | Interrupt pending  |   |     |     |     |     |     |
| <b>.0</b>      | <b>Timer 2 Overflow Interrupt pending Bit</b>     |  |   |     |     |     |     |     |
|                | 0   | No interrupt pending (Clears pending bit when write)         |   |     |     |     |     |     |
|                | 1   | Interrupt pending  |   |     |     |     |     |     |

| Bit Identifier  | .7  | .6                               | .5 | .4 | .3  | .2  | .1  | .0  |
|---|-----|----------------------------------|----|----|-----|-----|-----|-----|
| RESET Value   | 0   | –                                | –  | –  | 0   | 0   | 0   | 0   |
| Read/Write  | R/W | –                                | –  | –  | R/W | R/W | R/W | R/W |
| <b>.7</b>   |     |                                  |    |    |     |     |     |     |
| <b>Timer 2 clock source selection</b>   |     |                                  |    |    |     |     |     |     |
|   | 0   | Internal clock source            |    |    |     |     |     |     |
|   | 1   | External clock source from T2CLK |    |    |     |     |     |     |
| <b>.6– .5</b>   |     |                                  |    |    |     |     |     |     |
| <b>Not used for S3F8S19/F8S15</b>   |     |                                  |    |    |     |     |     |     |
| <b>.3– .0</b>   |     |                                  |    |    |     |     |     |     |
| <b>Timer 2 pre-scalar bits</b>  |     |                                  |    |    |     |     |     |     |
| T2PS = T2 clock/ ( $2^{T2PS[3-0]}$ ) Pre-scalar values higher than 12 are invalid |     |                                  |    |    |     |     |     |     |

| Bit Identifier  | .7  | .6  | .5  | .4  | .3  | .2  | .1  | .0  |
|---|---|---|---|-----|-----|-----|-----|-----|
| nRESET Value  | 0   | 0   | 0   | 0   | 0   | 0   | 0   | 0   |
| Read/Write  | R/W   | R/W   | R/W   | R/W | R/W | R/W | R/W | R/W |
| Addressing Mode   | Register addressing mode only   |   |   |     |     |     |     |     |
| <b>.7– .6      UART 0 Mode Selection Bits</b>                                   |   |   |   |     |     |     |     |     |
|   | 0   | 0   | Mode 0: Shift register ( $f_{xx}/(16 \times (BR0DATA + 1))$ ) |     |     |     |     |     |
|   | 0   | 1   | Mode 1: 8-bit UART ( $f_{xx}/(16 \times (BR0DATA + 1))$ )     |     |     |     |     |     |
|   | 1   | 0   | Mode 2: 9-bit UART ( $f_{xx}/16$ )                            |     |     |     |     |     |
|   | 1   | 1   | Mode 3: 9-bit UART ( $f_{xx}/(16 \times (BR0DATA + 1))$ )     |     |     |     |     |     |
| <b>.5      Multiprocessor Communication Enable Bit (for Modes 2 and 3 Only)</b> |   |   |   |     |     |     |     |     |
|   | 0   | Disables  |   |     |     |     |     |     |
|   | 1   | Enables   |   |     |     |     |     |     |
| <b>.4      Serial Data Receive Enable Bit</b>                                   |   |   |   |     |     |     |     |     |
|   | 0   | Disables  |   |     |     |     |     |     |
|   | 1   | Enables   |   |     |     |     |     |     |
| <b>.3      TB8 (Only when UART0CONL.7 = 0)</b>                                  |   |   |   |     |     |     |     |     |
|   | Location of the ninth data bit to be transmitted in Universal Asynchronous Receiver/Transmitter (UART) 0 mode 2 or 3 ("0" or "1") |   |   |     |     |     |     |     |
|   | NOTE: When UART0CONL.7 = 1, this bit is "don't care".   |   |   |     |     |     |     |     |
| <b>.2      RB8 (Only when UART0CONL.7 = 0)</b>                                  |   |   |   |     |     |     |     |     |
|   | Location of the ninth data bit to be received in UART 0 mode 2 or 3 ("0" or "1")  |   |   |     |     |     |     |     |
|   | Note: When UART0CONL.7 = 1, this bit is "don't care".   |   |   |     |     |     |     |     |
| <b>.1      UART 0 Receive Interrupt Enable Bit</b>                              |   |   |   |     |     |     |     |     |
|   | 0   | Disables Rx interrupt   |   |     |     |     |     |     |
|   | 1   | Enables Rx interrupt  |   |     |     |     |     |     |
| <b>.0      UART 0 Receive Interrupt Pending Bit</b>                             |   |   |   |     |     |     |     |     |
|   | 0   | No interrupt pending (when read), Clears pending bit (when write) |   |     |     |     |     |     |
|   | 1   | Interrupt is pending (when read)                                  |   |     |     |     |     |     |

|                        |  |   |           |           |           |           |           |           |
|------------------------|--|---|-----------|-----------|-----------|-----------|-----------|-----------|
| <b>Bit Identifier</b>  | <b>.7</b>  | <b>.6</b>   | <b>.5</b> | <b>.4</b> | <b>.3</b> | <b>.2</b> | <b>.1</b> | <b>.0</b> |
| <b>nRESET Value</b>    | 0  | 0   | 0         | 0         | 0         | 0         | 0         | 0         |
| <b>Read/Write</b>      | R/W  | R/W   | R/W       | R/W       | R/W       | R/W       | R/W       | R/W       |
| <b>Addressing Mode</b> | Register addressing mode only  |   |           |           |           |           |           |           |
| <b>.7</b>              | <b>UART 0 Transmit Parity-bit Auto-Generation Enable Bit</b>               |   |           |           |           |           |           |           |
|                        | 0  | Disables parity-bit auto-generation                               |           |           |           |           |           |           |
|                        | 1  | Enables parity-bit auto-generation                                |           |           |           |           |           |           |
| <b>.6</b>              | <b>UART 0 Transmit Parity-bit Selection Bit (for Modes 2 and 3 ONLY)</b>   |   |           |           |           |           |           |           |
|                        | 0  | Even parity-bit   |           |           |           |           |           |           |
|                        | 1  | Odd parity-bit  |           |           |           |           |           |           |
|                        | NOTE: When UART0CONL.7 = 0, this bit is "don't care".                      |   |           |           |           |           |           |           |
| <b>.5</b>              | <b>UART 0 Receive Parity-bit Selection Bit (for Modes 2 and 3 Only)</b>    |   |           |           |           |           |           |           |
|                        | 0  | Even parity-bit check   |           |           |           |           |           |           |
|                        | 1  | Odd parity-bit check  |           |           |           |           |           |           |
|                        | NOTE: When UART0CONL.7 = 0, this bit is "don't care".                      |   |           |           |           |           |           |           |
| <b>.4</b>              | <b>UART 0 Receive Parity-bit Error Status Bit (for Modes 2 and 3 Only)</b> |   |           |           |           |           |           |           |
|                        | 0  | No parity-bit error   |           |           |           |           |           |           |
|                        | 1  | Parity-bit error  |           |           |           |           |           |           |
|                        | NOTE: When UART0CONL.7 = 0, this bit is "don't care".                      |   |           |           |           |           |           |           |
| <b>.3– .2</b>          | <b>UART 0 Clock Selection Bits</b>   |   |           |           |           |           |           |           |
|                        | 0  | 0   | fxx/8     |           |           |           |           |           |
|                        | 0  | 1   | fxx/4     |           |           |           |           |           |
|                        | 1  | 0   | fxx/2     |           |           |           |           |           |
|                        | 1  | 1   | fxx/1     |           |           |           |           |           |
| <b>.1</b>              | <b>Uart 0 Transmit Interrupt Enable Bit</b>                                |   |           |           |           |           |           |           |
|                        | 0  | Disables Tx interrupt   |           |           |           |           |           |           |
|                        | 1  | Enables Tx interrupt  |           |           |           |           |           |           |
| <b>.0</b>              | <b>Uart 0 Transmit Interrupt Pending Bit</b>                               |   |           |           |           |           |           |           |
|                        | 0  | No interrupt pending (when read), clears pending bit (when write) |           |           |           |           |           |           |
|                        | 1  | Interrupt is pending (when read)                                  |           |           |           |           |           |           |

| Bit Identifier  | .7  | .6  | .5  | .4  | .3  | .2  | .1  | .0  |
|---|---|---|---|-----|-----|-----|-----|-----|
| nRESET Value  | 0   | 0   | 0   | 0   | 0   | 0   | 0   | 0   |
| Read/Write  | R/W   | R/W   | R/W   | R/W | R/W | R/W | R/W | R/W |
| Addressing Mode   | Register addressing mode only   |   |   |     |     |     |     |     |
| <b>.7– .6      UART 1 Mode Selection Bits</b>                                   |   |   |   |     |     |     |     |     |
|   | 0   | 0   | Mode 0: Shift register ( $f_{xx}/(16 \times (BR0DATA + 1))$ ) |     |     |     |     |     |
|   | 0   | 1   | Mode 1: 8-bit UART( $f_{xx}/(16 \times (BR0DATA + 1))$ )      |     |     |     |     |     |
|   | 1   | 0   | Mode 2: 9-bit UART( $f_{xx}/16$ )                             |     |     |     |     |     |
|   | 1   | 1   | Mode 3: 9-bit UART( $f_{xx}/(16 \times (BR0DATA + 1))$ )      |     |     |     |     |     |
| <b>.5      Multiprocessor Communication Enable Bit (for Modes 2 and 3 Only)</b> |   |   |   |     |     |     |     |     |
|   | 0   | Disables  |   |     |     |     |     |     |
|   | 1   | Enables   |   |     |     |     |     |     |
| <b>.4      Serial Data Receive Enable Bit</b>                                   |   |   |   |     |     |     |     |     |
|   | 0   | Disables  |   |     |     |     |     |     |
|   | 1   | Enables   |   |     |     |     |     |     |
| <b>.3      TB8 (Only when UART1CONL.7 = 0)</b>                                  |   |   |   |     |     |     |     |     |
|   | Location of the ninth data bit to be transmitted in UART 0 mode 2 or 3 ("0" or "1") |   |   |     |     |     |     |     |
|   | NOTE: When UART0CONL.7 = 1, this bit is "don't care".                               |   |   |     |     |     |     |     |
| <b>.2      RB8 (Only when UART1CONL.7 = 0)</b>                                  |   |   |   |     |     |     |     |     |
|   | Location of the ninth data bit to be received in UART 0 mode 2 or 3 ("0" or "1")    |   |   |     |     |     |     |     |
|   | NOTE: When UART0CONL.7 = 1, this bit is "don't care".                               |   |   |     |     |     |     |     |
| <b>.1      Uart 1 Receive Interrupt Enable Bit</b>                              |   |   |   |     |     |     |     |     |
|   | 0   | Disables Rx interrupt   |   |     |     |     |     |     |
|   | 1   | Enables Rx interrupt  |   |     |     |     |     |     |
| <b>.0      Uart 1 Receive Interrupt Pending Bit</b>                             |   |   |   |     |     |     |     |     |
|   | 0   | No interrupt pending (when read), clears pending bit (when write) |   |     |     |     |     |     |
|   | 1   | Interrupt is pending (when read)                                  |   |     |     |     |     |     |

4.1.64 UART1CONL-UART 1 Control Register Low Byte (05H, PAGE8)

| Bit Identifier   | .7                            | .6  | .5    | .4  | .3  | .2  | .1  | .0  |
|--|-------------------------------|---|-------|-----|-----|-----|-----|-----|
| nRESET Value   | 0                             | 0   | 0     | 0   | 0   | 0   | 0   | 0   |
| Read/Write   | R/W                           | R/W   | R/W   | R/W | R/W | R/W | R/W | R/W |
| Addressing Mode  | Register addressing mode only |   |       |     |     |     |     |     |
| <b>.7</b>  |                               |   |       |     |     |     |     |     |
| <b>UART 1 Transmit Parity-bit Auto-Generation Enable Bit</b>               |                               |   |       |     |     |     |     |     |
|  | 0                             | Disables parity-bit auto-generation                               |       |     |     |     |     |     |
|  | 1                             | Enables parity-bit auto-generation                                |       |     |     |     |     |     |
| <b>.6</b>  |                               |   |       |     |     |     |     |     |
| <b>UART 1 Transmit Parity-bit Selection Bit (for Modes 2 and 3 Only)</b>   |                               |   |       |     |     |     |     |     |
|  | 0                             | Even parity-bit   |       |     |     |     |     |     |
|  | 1                             | Odd parity-bit  |       |     |     |     |     |     |
| NOTE: When UART1CONL.7 = 0, this bit is "don't care".                      |                               |   |       |     |     |     |     |     |
| <b>.5</b>  |                               |   |       |     |     |     |     |     |
| <b>UART 1 Receive Parity-bit Selection Bit (for Modes 2 and 3 Only)</b>    |                               |   |       |     |     |     |     |     |
|  | 0                             | Even parity-bit check   |       |     |     |     |     |     |
|  | 1                             | Odd parity-bit check  |       |     |     |     |     |     |
| NOTE: When UART1CONL.7 = 0, this bit is "don't care".                      |                               |   |       |     |     |     |     |     |
| <b>.4</b>  |                               |   |       |     |     |     |     |     |
| <b>UART 1 Receive Parity-bit Error Status Bit (for Modes 2 and 3 Only)</b> |                               |   |       |     |     |     |     |     |
|  | 0                             | No parity-bit error   |       |     |     |     |     |     |
|  | 1                             | Parity-bit error  |       |     |     |     |     |     |
| NOTE: When UART1CONL.7 = 0, this bit is "don't care".                      |                               |   |       |     |     |     |     |     |
| <b>.3– .2</b>  |                               |   |       |     |     |     |     |     |
| <b>UART 1 Clock Selection Bits</b>   |                               |   |       |     |     |     |     |     |
|  | 0                             | 0   | fxx/8 |     |     |     |     |     |
|  | 0                             | 1   | fxx/4 |     |     |     |     |     |
|  | 1                             | 0   | fxx/2 |     |     |     |     |     |
|  | 1                             | 1   | fxx/1 |     |     |     |     |     |
| <b>.1</b>  |                               |   |       |     |     |     |     |     |
| <b>Uart 1 Transmit Interrupt Enable Bit</b>                                |                               |   |       |     |     |     |     |     |
|  | 0                             | Disables Tx interrupt   |       |     |     |     |     |     |
|  | 1                             | Enables Tx interrupt  |       |     |     |     |     |     |
| <b>.0</b>  |                               |   |       |     |     |     |     |     |
| <b>Uart 1 Transmit Interrupt Pending Bit</b>                               |                               |   |       |     |     |     |     |     |
|  | 0                             | No interrupt pending (when read), clears pending bit (when write) |       |     |     |     |     |     |
|  | 1                             | Interrupt is pending (when read)                                  |       |     |     |     |     |     |

4.1.65 WTCN-Watch Timer Control Register (FAH, BANK0)

| Bit Identifier                           | .7                            | .6   | .5                                     | .4  | .3  | .2  | .1  | .0  |
|--|-------------------------------|--|--|-----|-----|-----|-----|-----|
| nRESET Value                             | 0                             | 0  | 0                                      | 0   | 0   | 0   | 0   | 0   |
| Read/Write                               | R/W                           | R/W  | R/W                                    | R/W | R/W | R/W | R/W | R/W |
| Addressing Mode                          | Register addressing mode only |  |  |     |     |     |     |     |
| <b>.7</b>                                |                               |  |  |     |     |     |     |     |
| <b>Watch Timer Clock Selection Bit</b>   |                               |  |  |     |     |     |     |     |
|  | 0                             | Selects main clock divided by 128 (fx/128)                                   |  |     |     |     |     |     |
|  | 1                             | Selects sub clock (fxt)  |  |     |     |     |     |     |
| <b>.6</b>                                |                               |  |  |     |     |     |     |     |
| <b>Watch Timer Interrupt Enable Bit</b>  |                               |  |  |     |     |     |     |     |
|  | 0                             | Disables watch timer interrupt   |  |     |     |     |     |     |
|  | 1                             | Enables watch timer interrupt  |  |     |     |     |     |     |
| <b>.5– .4</b>                            |                               |  |  |     |     |     |     |     |
| <b>Buzzer Signal Selection Bits</b>      |                               |  |  |     |     |     |     |     |
|  | 0                             | 0  | 0.5 kHz                                |     |     |     |     |     |
|  | 0                             | 1  | 1.0 kHz                                |     |     |     |     |     |
|  | 1                             | 0  | 2.0 kHz                                |     |     |     |     |     |
|  | 1                             | 1  | 4.0 kHz                                |     |     |     |     |     |
| <b>.3– .2</b>                            |                               |  |  |     |     |     |     |     |
| <b>Watch Timer Speed Selection Bits</b>  |                               |  |  |     |     |     |     |     |
|  | 0                             | 0  | Sets watch timer interrupt to 0.5 s    |     |     |     |     |     |
|  | 0                             | 1  | Sets watch timer interrupt to 0.25 s   |     |     |     |     |     |
|  | 1                             | 0  | Sets watch timer interrupt to 0.125 s  |     |     |     |     |     |
|  | 1                             | 1  | Sets watch timer interrupt to 1.995 ms |     |     |     |     |     |
| <b>.1</b>                                |                               |  |  |     |     |     |     |     |
| <b>Watch Timer Enable Bit</b>            |                               |  |  |     |     |     |     |     |
|  | 0                             | Disables watch timer. Clears frequency dividing circuits                     |  |     |     |     |     |     |
|  | 1                             | Enables watch timer  |  |     |     |     |     |     |
| <b>.0</b>                                |                               |  |  |     |     |     |     |     |
| <b>Watch Timer Interrupt Pending Bit</b> |                               |  |  |     |     |     |     |     |
|  | 0                             | Interrupt request is not pending; (when read) pending bit clear when write 0 |  |     |     |     |     |     |
|  | 1                             | Interrupt request is pending (when read)                                     |  |     |     |     |     |     |

# 5

## Interrupt Structure

### 5.1 Overview

The S3C8/S3F8-series interrupt structure has three basic components:

- Levels
- Vectors
- Sources

The SAM8RC CPU recognizes up to eight interrupt levels and supports up to 128 interrupt vectors. When a specific interrupt level has multiple vector addresses, the vector priorities are established in hardware. A vector address can be assigned to one or more sources.

#### 5.1.1 Levels

Interrupt levels are the main unit for interrupt priority assignment and recognition. All peripherals and Input/Output (I/O) blocks can issue interrupt requests. Alternatively, the peripheral and I/O operations are interrupt-driven. There are eight possible interrupt levels: IRQ0–IRQ7, also called level 0–level 7. Each interrupt level directly corresponds to an interrupt request number (IRQn). The total number of interrupt levels used in the interrupt structure varies from device to device. The S3F8S19/F8S15 microcontroller interrupt structure recognizes eight interrupt levels.

The interrupt level numbers 0 through 7 do not necessarily indicate the relative priority of the levels. They are just identifiers for the interrupt levels that are recognized by the CPU. The settings in the interrupt priority register (IPR) determine the relative priority of different interrupt levels. Interrupt group and subgroup logic that IPR settings control enables you to define more complex priority relationships between different levels.

#### 5.1.2 Vectors

Each interrupt level can have one or more interrupt vectors, or it may have no vector address assigned at all. The maximum number of vectors that can be supported for a given level is 128 (The actual number of vectors used for S3C8/S3F8-series devices is always much smaller). If an interrupt level has multiple vector addresses, the vector priorities are set in hardware. The S3F8S19/F8S15 microcontroller uses 26 vectors.



### 5.1.3 Sources

A source is any peripheral that generates an interrupt. A source can be an external pin or a counter overflow. Each vector can have several interrupt sources. In S3F8S19/F8S15 microcontroller interrupt structure; there are 26 possible interrupt sources, which mean every source has its own vector.

When a service routine starts, the respective pending bit should be either cleared automatically by hardware or cleared "manually" by software. The characteristics of the pending mechanism of source determine which method would be used to clear its respective pending bit.

### 5.2 Interrupt Types

The three components of the S3C8/S3F8 interrupt structure described before-levels, vectors, and sources-are combined. It combines them to determine the interrupt structure of an individual device and to make full use of its available interrupt logic. There are three possible combinations of interrupt structure components, called interrupt types 1, 2, and 3. The types differ in the number of vectors and interrupt sources that it assigns to each level (Refer to [Figure 5-1](#) for more information):

- Type 1: One level (IRQn) + one vector (V<sub>1</sub>) + one source (S<sub>1</sub>)
- Type 2: One level (IRQn) + one vector (V<sub>1</sub>) + multiple sources (S<sub>1</sub> – S<sub>n</sub>)
- Type 3: One level (IRQn) + multiple vectors (V<sub>1</sub> – V<sub>n</sub>) + multiple sources (S<sub>1</sub> – S<sub>n</sub>, S<sub>n+1</sub> – S<sub>n+m</sub>)

In the S3F8S19/F8S15 microcontroller, two interrupt types are implemented.

[Figure 5-1](#) illustrates the interrupt types of S3C8/S3F8-Series.

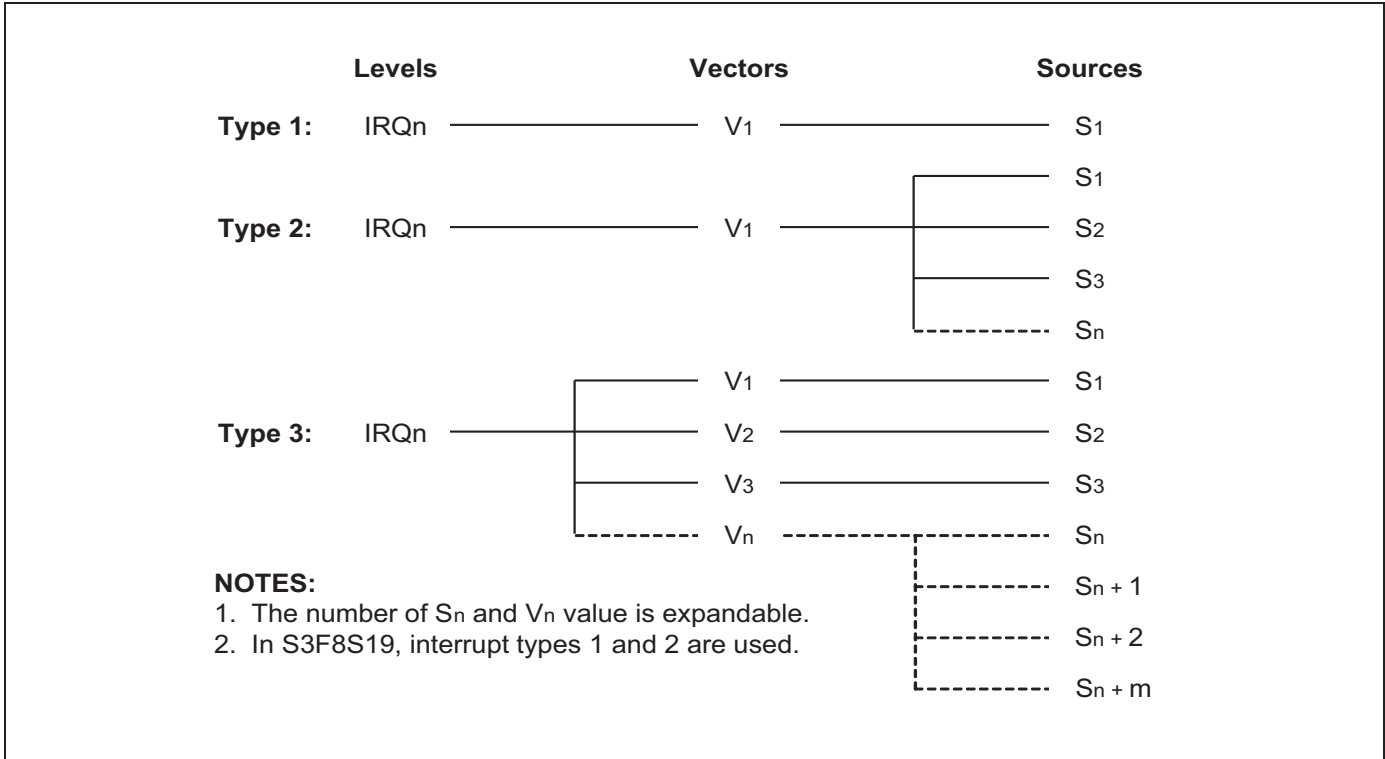


Figure 5-1 S3C8/S3F8-Series Interrupt Types

### 5.3 S3F8S19/F8S15 Interrupt Structure

The S3F8S19/F8S15 microcontroller supports 26 interrupt sources. Every interrupt source has a corresponding interrupt address. Eight interrupt levels are recognized by the CPU in this device-specific interrupt structure, as illustrated in [Figure 5-2](#).

When multiple interrupt levels are active, the interrupt priority register (IPR) determines the order in which contending interrupts are to be serviced. If multiple interrupts occur within the same interrupt level, the interrupt with the lowest vector address is usually processed first (The relative priorities of multiple interrupts within a single level are fixed in hardware).

When the CPU grants an interrupt request, interrupt processing starts. All other interrupts are disabled and the program counter value and status flags are pushed to stack. The starting address of the service routine is fetched from the appropriate vector address (plus the next 8-bit value to concatenate the full 16-bit address) and the service routine is executed.

[Figure 5-2](#) illustrates the S3F8S19/F8S15 interrupt structure.

| LEVEL  | VECTOR | SOURCE                         | RESET/CLEAR  |
|--------|--------|--------------------------------|--------------|
| nRESET | 100H   | Basic Timer overflow           | H / W        |
|        | CCH    | STW Timer                      | S / W        |
| IRQ0   | CEH    | Timer A match/capture          | S / W        |
|        | D0H    | Timer A overflow               | H / W, S / W |
| IRQ1   | D2H    | Timer B match                  | H / W        |
| IRQ2   | D4H    | Timer 0 match                  | S / W        |
|        | D6H    | Timer 0 overflow               | H / W, S / W |
| IRQ3   | D8H    | Timer 1 match/capture          | S / W        |
|        | DAH    | Timer 1 overflow               | H / W, S / W |
|        | DCH    | Timer 2 match/capture          | S / W        |
| IRQ4   | DEH    | Timer 2 overflow               | H / W, S / W |
|        | E0H    | LVD interrupt                  | H / W        |
|        | E2H    | Watch timer overflow           | S / W        |
|        | E4H    | SPI Interrupt                  | H / W, S / W |
| IRQ5   | E6H    | IIC transmit/receive interrupt | S / W        |
|        | E8H    | UART0 data transmit            | S / W        |
|        | EAH    | UART0 data receive             | S / W        |
|        | ECH    | UART1 data transmit            | S / W        |
|        | EEH    | UART1 data receive             | S / W        |
| IRQ6   | F0H    | P0.0 External Interrupt        | S / W        |
|        | F2H    | P0.1 External Interrupt        | S / W        |
|        | F4H    | P0.2 External Interrupt        | S / W        |
|        | F6H    | P0.3 External Interrupt        | S / W        |
| IRQ7   | F8H    | P3.4 External Interrupt        | S / W        |
|        | FAH    | P3.5 External Interrupt        | S / W        |
|        | FCH    | P3.6 External Interrupt        | S / W        |
|        | FEH    | P3.7 External Interrupt        | S / W        |

**Figure 5-2 S3F8S19/F8S15 Interrupt Structure**

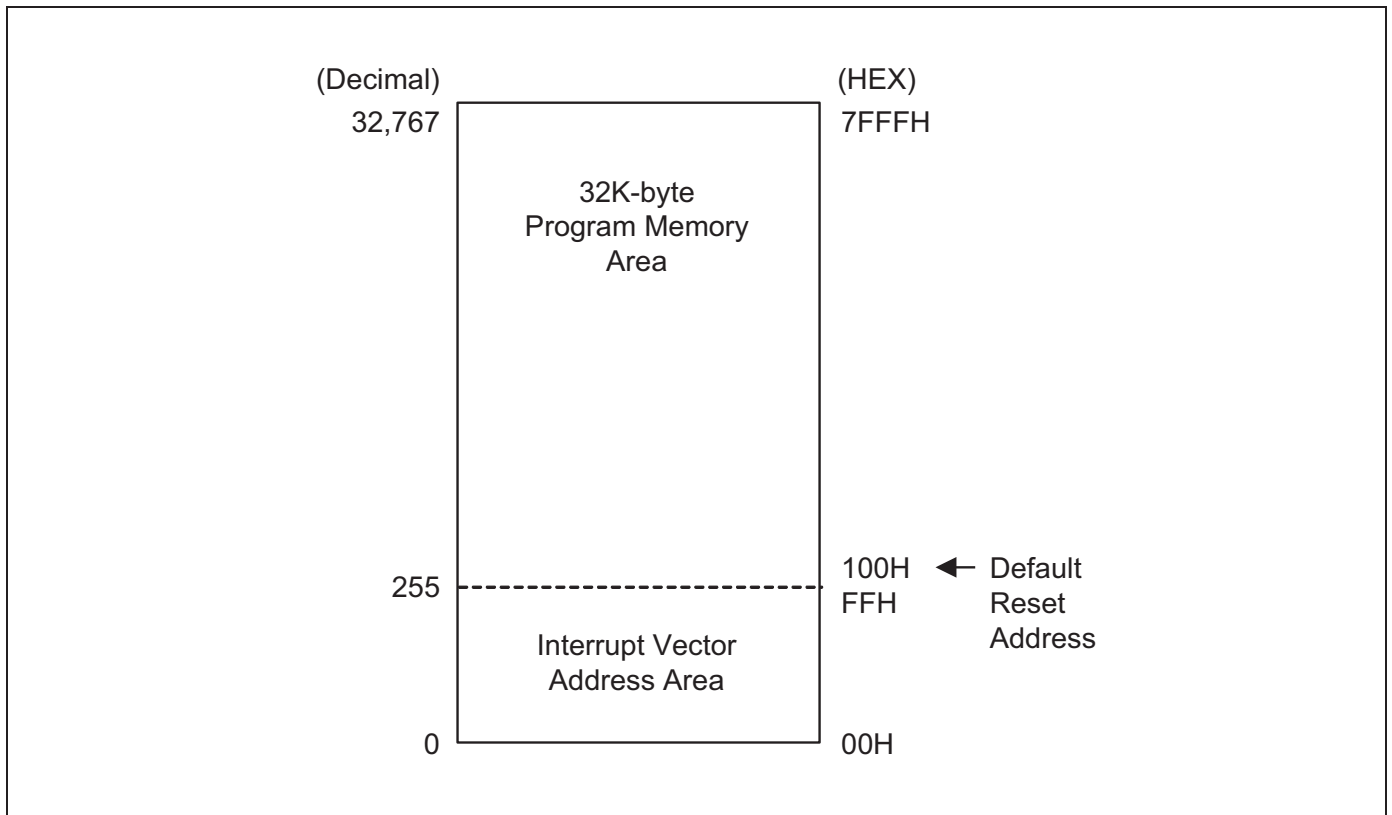
### 5.3.1 Interrupt Vector Addresses

All interrupt vector addresses for the S3F8S19/F8S15 interrupt structure is stored in the vector address area of the first 256 bytes of the program memory (ROM).

You can allocate unused locations in the vector address area as normal program memory. If you do so, ensure not to overwrite any of the stored vector addresses.

The default program reset address in the ROM is 0100H.

[Figure 5-3](#) illustrates the ROM vector address area.



**Figure 5-3 ROM Vector Address Area**

### 5.3.2 Enable/Disable Interrupt Instructions (EI, DI)

Executing the Enable Interrupts (EI) instruction globally enables the interrupt structure. All interrupts are then serviced as they occur according to the established priorities.

**NOTE:** The system initialization routine executed after a reset should always contain an EI instruction to globally enable the interrupt structure.

During the normal operation, you can execute the Disable Interrupt (DI) instruction at any time to globally disable interrupt processing. The EI and DI instructions change the value of bit 0 in the system mode register (SYM) register.

## 5.4 System-Level Interrupt Control Registers

In addition to the control registers for specific interrupt sources, there are four system-level registers control interrupt processing. They are:

- The interrupt mask register, IMR, enables (un-masks) or disables (masks) interrupt levels.
- The interrupt priority register, IPR, controls the relative priorities of interrupt levels.
- The interrupt request register, IRQ, contains interrupt pending flags for each interrupt level (as opposed to each interrupt source).
- The system mode register, SYM, enables or disables global interrupt processing (SYM settings also enable fast interrupts and control the activity of external interface, if implemented).

[Table 5-1](#) describes the interrupt control register.

**Table 5-1 Interrupt Control Register Overview**

| Control Register            | ID  | R/W | Function Description   |
|-----------------------------|-----|-----|--|
| Interrupt mask register     | IMR | R/W | Bit settings in the IMR register enables or disables processing of interrupt for each of the eight interrupt levels: IRQ0–IRQ7.  |
| Interrupt priority register | IPR | R/W | Controls the relative processing priorities of the interrupt levels. The eight levels of S3F8S19/F8S15 are organized into three groups: A, B and C. Group A is IRQ0 and IRQ1, group B is IRQ2, IRQ3 and IRQ4, and group C is IRQ5, IRQ6, and IRQ7. |
| Interrupt request register  | IRQ | R   | This register contains a request pending bit for each interrupt level.   |
| System mode register        | SYM | R/W | This register enables/disables fast interrupt processing, and dynamic global interrupt processing.   |

**NOTE:** All interrupts must be disabled before IMR register is changed to any value. Using DI instruction is recommended.

## 5.5 Interrupt Processing Control Points

Interrupt processing can therefore be controlled in two ways:

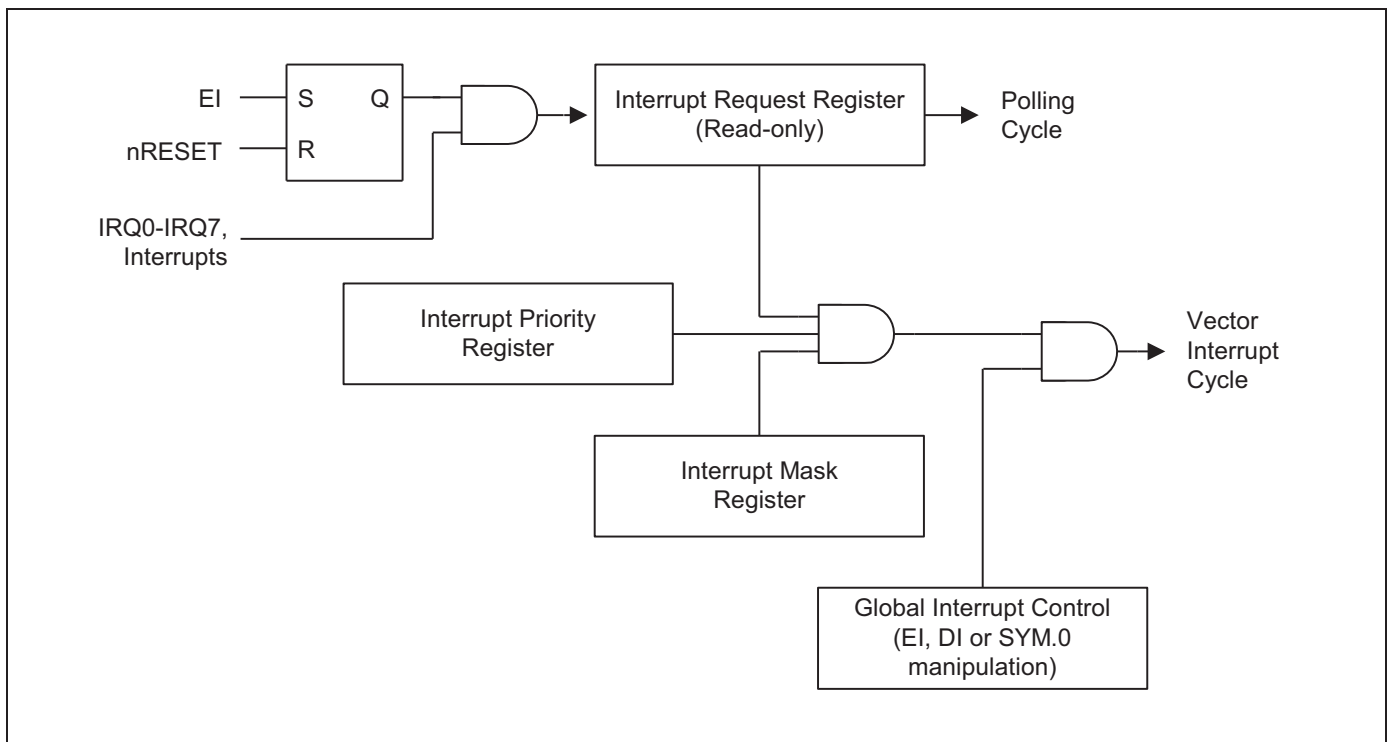
- globally
- specific interrupt level and source

The system-level control points in the interrupt structure are:

- Global interrupt enable and disable (by EI and DI instructions or by direct manipulation of SYM.0)
- Interrupt level enable/disable settings (IMR register)
- Interrupt level priority settings (IPR register)
- Interrupt source enable/disable settings in the corresponding peripheral control registers

**NOTE:** While writing an application program that handles interrupt processing, ensure to include the necessary register file address (register pointer) information.

[Figure 5-4](#) illustrates the interrupt function diagram.



**Figure 5-4** Interrupt Function Diagram

## 5.6 Peripheral Interrupt Control Registers

For each interrupt source there is one or more corresponding peripheral control registers that enable you to control the interrupt generated by the related peripheral (Refer to [Table 5-2](#) for more information).

[Table 5-2](#) lists the interrupt source control and data registers.

**Table 5-2 Interrupt Source Control and Data Registers**

| Interrupt Source   | Interrupt Level | Register (s)  | Location (s)   |
|--|-----------------|---|--|
| Timer A overflow<br>Timer A match/capture<br>Stop Wake up Timer                          | IRQ0            | TACON<br>TAPS<br>TADATA<br>TACNT<br>SWTCON  | E2H, BANK0<br>E3H, BANK0<br>E1H, BANK0<br>E0H, BANK0<br>10H, PAGE8   |
| Timer B match  | IRQ1            | TBCON<br>TBDATA0H<br>TBDATA0L<br>TBDATA1H<br>TBDATA1L<br>TBTRG  | 11H, PAGE8<br>12H, PAGE8<br>13H, PAGE8<br>14H, PAGE8<br>15H, PAGE8<br>16H, PAGE8   |
| Timer 0 overflow<br>Timer 0 match/capture  | IRQ2            | T0CON<br>T0DATAH<br>T0DATAL<br>T0CNTH<br>T0CNTL<br>T0PS   | ECH, BANK0<br>EAH, BANK0<br>EBH, BANK0<br>E8H, BANK0<br>E9H, BANK0<br>EDH, BANK0   |
| Timer 1 overflow<br>Timer 1 match/capture<br>Timer 2 overflow<br>Timer 2 match/capture   | IRQ3            | T1CON<br>T1DATAH<br>T1DATAL<br>T1CNTH<br>T1CNTL<br>T1PS T2CON<br>T2DATAH<br>T2DATAL<br>T2CNTH<br>T2CNTL<br>T2PS | F2H, BANK0<br>F0H, BANK0<br>F1H, BANK0<br>EEH, BANK0<br>EFH, BANK0<br>F3H, BANK0<br>F8H, BANK0<br>F6H, BANK0<br>F7H, BANK0<br>F4H, BANK0<br>F5H, BANK0<br>F9H, BANK0 |
| LVD Interrupt<br>Watch Timer overflow<br>SPI Interrupt<br>IIC transmit/receive Interrupt | IRQ4            | LVDCON<br>WTCON<br>SPICCON<br>SPISTAT<br>SPIDATA<br>ICCR<br>ICSR  | FEH, BANK1<br>FAH, BANK0<br>F7H, BANK1<br>F8H, BANK1<br>F9H, BANK1<br>0CH, PAGE8<br>0DH, PAGE8   |

| Interrupt Source   | Interrupt Level | Register (s)                                | Location (s)   |
|--|-----------------|---|--|
|  |                 | IDSR<br>IAR                                 | 0EH, PAGE8<br>0FH, PAGE8                             |
| UART0 data transmit<br>UART0 data receive<br>UART1 data transmit<br>UART1 data receive | IRQ5            | UART0CONH<br>UART0CONL<br>UDATA0<br>BRDATA0 | 00H, PAGE8<br>01H, PAGE8<br>02H, PAGE8<br>03H, PAGE8 |
| P0.0 External Interrupt  | IRQ6            | P0CONL<br>P0INT<br>PINTPND                  | E1H, BANK1<br>E3H, BANK1<br>F6H, BANK1               |
| P0.1 External Interrupt  |                 |   |  |
| P0.2 External Interrupt  |                 |   |  |
| P0.3 External Interrupt  |                 |   |  |
| P3.4 External Interrupt  | IRQ7            | P3CONH<br>P3INT<br>PINTPND                  | E8H, BANK1<br>EBH, BANK1<br>F6H, BANK1               |
| P3.5 External Interrupt  |                 |   |  |
| P3.6 External Interrupt  |                 |   |  |
| P3.7 External Interrupt  |                 |   |  |

**NOTE:** If an interrupt is un-masked (Enables interrupt level) in the IMR register, a DI instruction should be executed before clearing the pending bit or changing the enable bit of the corresponding interrupt.



### 5.7 System Mode Register (SYM)

The system mode register, SYM (DEH, Set1), is used to globally enable and disable interrupt processing and to control fast interrupt processing (Refer to [Figure 5-5](#) for more information).

A reset clears SYM.1 and SYM.0 to "0". The 3-bit value for fast interrupt level selection, SYM.4-SYM.2, is undetermined.

The instructions EI and DI enables and disables global interrupt processing, respectively, by modifying the bit 0 values of the SYM register. To enable interrupt processing an Enable Interrupt (EI) instruction must be included in the initialization routine, which follows a reset operation. Although you can manipulate SYM.0 directly to enable and disable interrupts during the normal operation, use EI and DI instructions for this purpose.

[Figure 5-5](#) illustrates the system mode register (SYM).

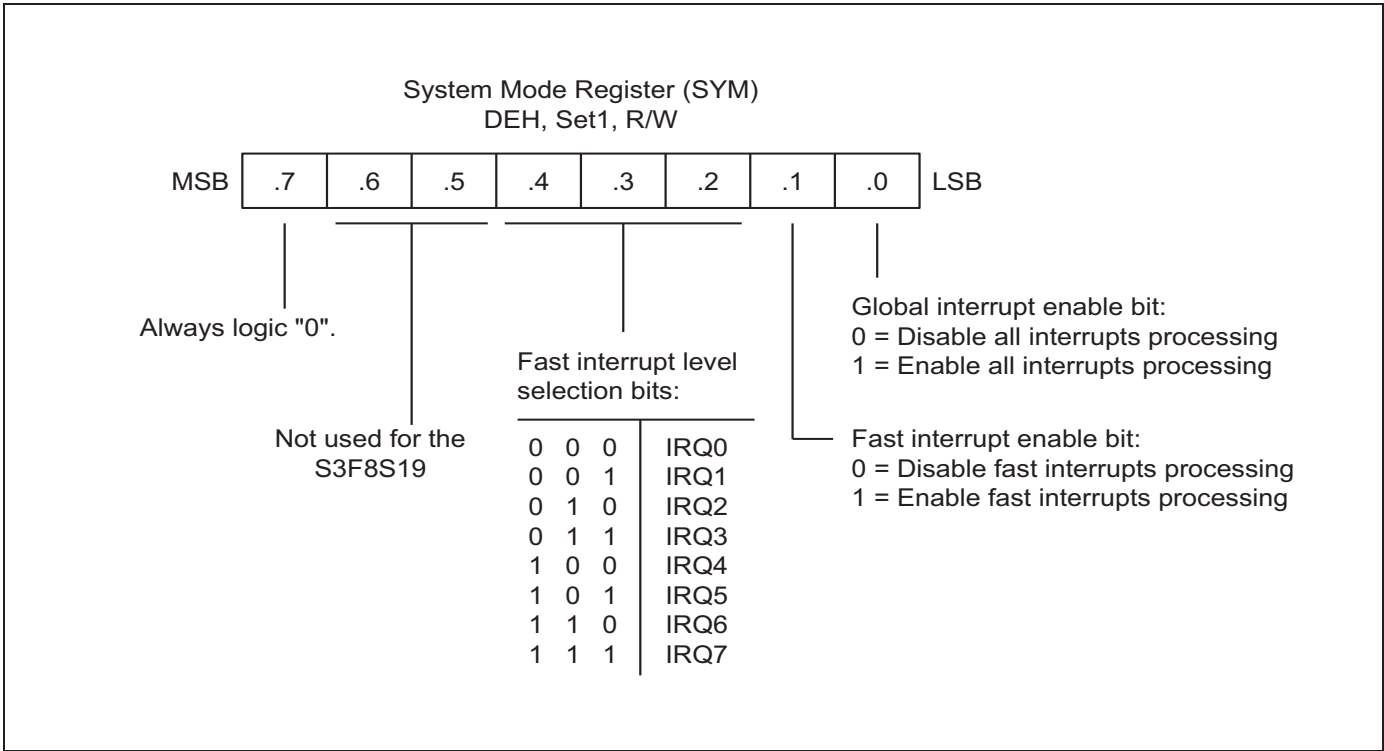


Figure 5-5 System Mode Register (SYM)

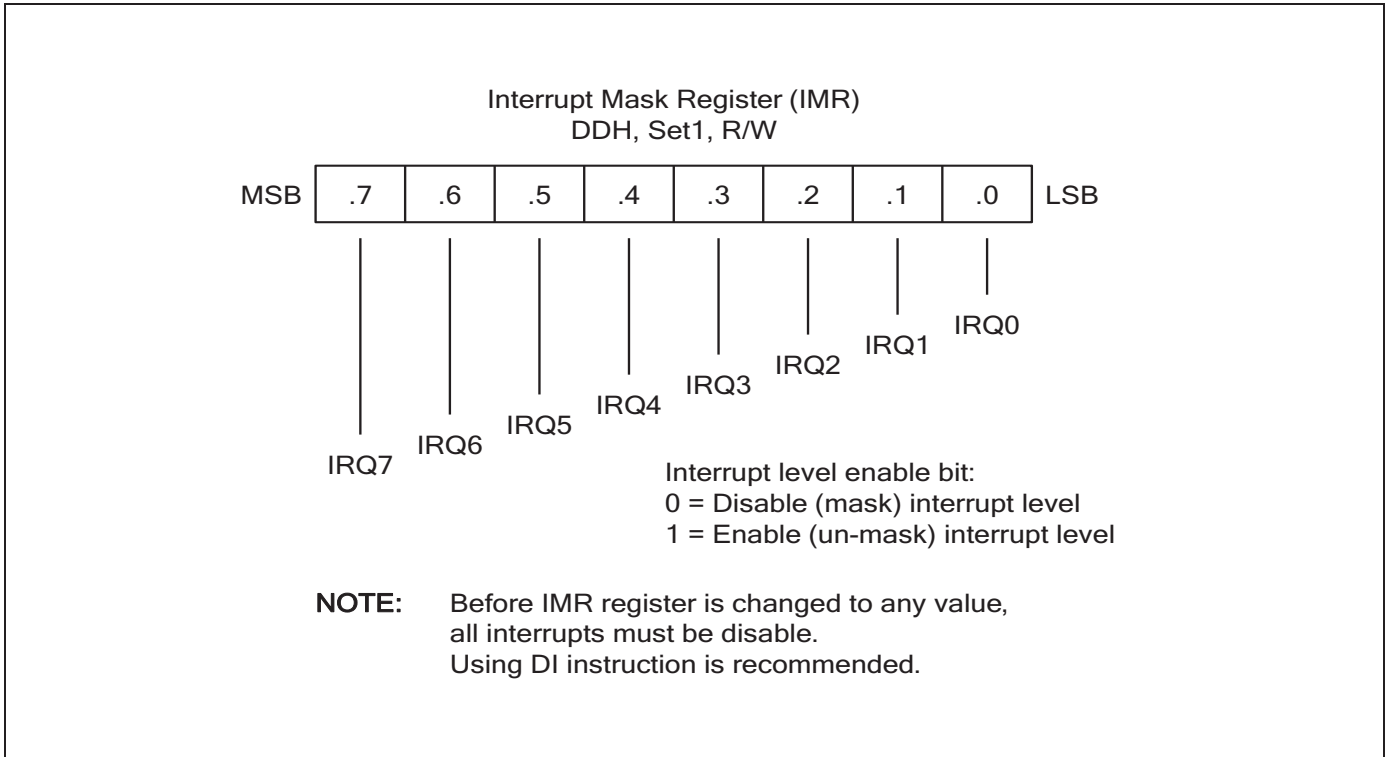
### 5.8 Interrupt Mask Register (IMR)

The interrupt mask register, IMR (DDH, Set1) is used to enable or disable interrupt processing for individual interrupt levels. After a reset, all IMR bit values are undetermined and therefore be written to their required settings by the initialization routine.

Each IMR bit corresponds to a specific interrupt level: bit 1 to IRQ1, bit 2 to IRQ2 and so on. When the IMR bit of an interrupt level is cleared to "0", interrupt processing for that level is disabled (masks). When you set a level's IMR bit to "1", interrupt processing for the level is enabled (does not mask).

The IMR register is mapped to register location DDH, Set1. Bit values can be read and written by instructions using the register addressing mode.

*Figure 5-6* illustrates the interrupt mask register (IMR).



**Figure 5-6** Interrupt Mask Register (IMR)

## 5.9 Interrupt Priority Register

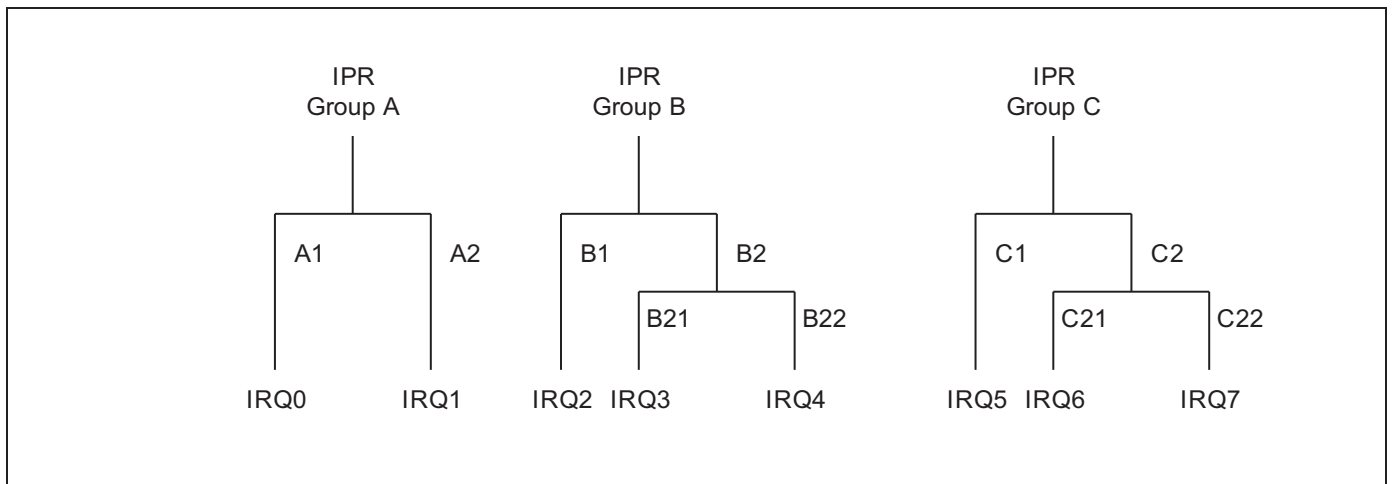
The interrupt priority register, IPR (FFH, Set1, Bank0), is used to set the relative priorities of the interrupt levels in the interrupt structure of microcontroller. After a reset, all IPR bit values are undetermined and therefore be written to their required settings by the initialization routine.

When multiple interrupt sources are active, the source with the highest priority level is serviced first. If two sources belong to the same interrupt level, the source with the lower vector address usually has the priority (This priority is fixed in hardware).

To support programming of the relative interrupt level priorities, they are organized into groups and subgroups by the interrupt logic. Note that these groups (and subgroups) are used only by IPR logic for the IPR register priority definitions (Refer to [Figure 5-7](#) for more information).

- Group A    IRQ0, IRQ1
- Group B    IRQ2, IRQ3, IRQ4
- Group C    IRQ5, IRQ6, IRQ7

[Figure 5-7](#) illustrates the interrupt request priority groups.



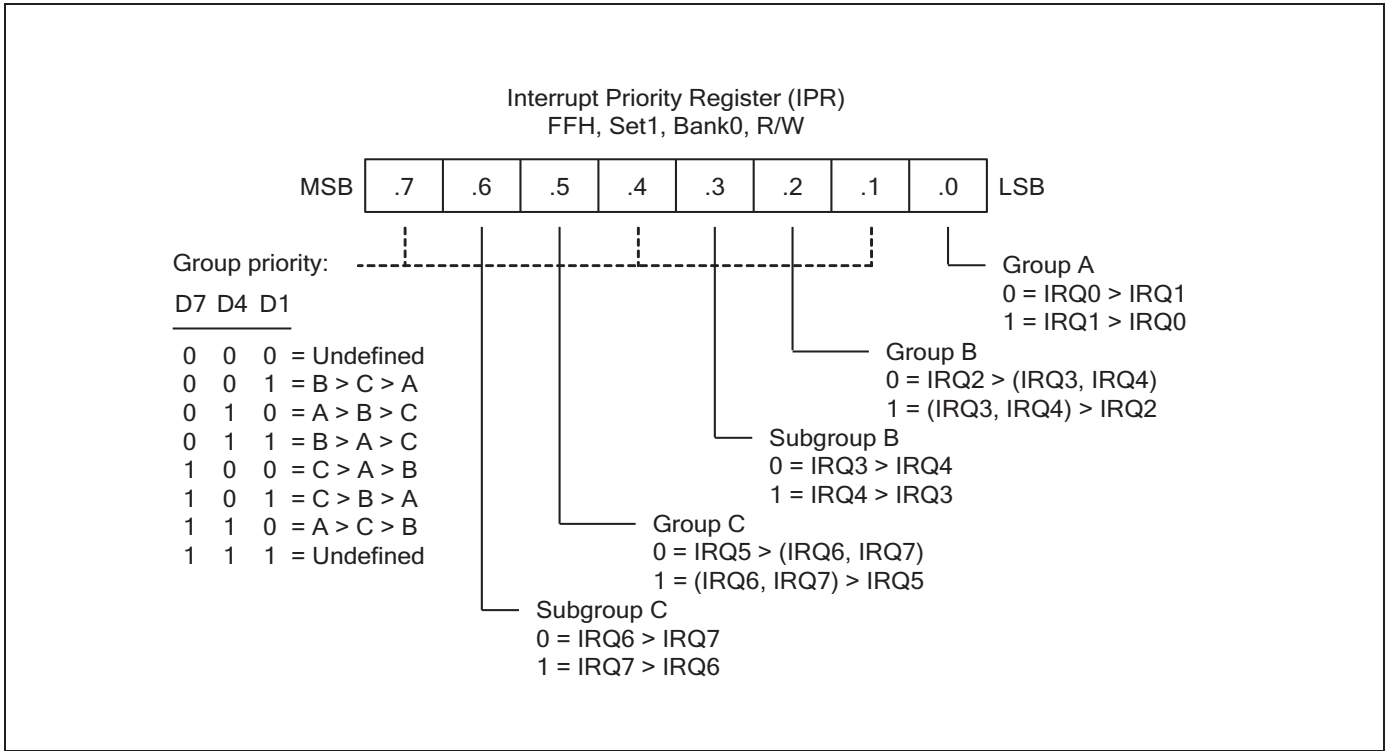
**Figure 5-7    Interrupt Request Priority Groups**

In [Figure 5-8](#), IPR.7, IPR.4 and IPR.1 controls the relative priority of interrupt groups A, B, and C. For example, the setting "001B" for these bits would select the group relationship B > C > A. The setting "101B" would select the relationship C > B > A.

The functions of the other IPR bit settings are:

- IPR.5 controls the relative priorities of group C interrupts.
- Interrupt group C includes a sub-group that has an additional priority relationship among the interrupt levels 5, 6, and 7. IPR.6 defines the subgroup C relationship. IPR.5 controls the interrupt group C.
- IPR.0 controls the relative priority setting of IRQ0 and IRQ1 interrupts.

[Figure 5-8](#) illustrates the interrupt priority register (IPR).



**Figure 5-8 Interrupt Priority Register (IPR)**

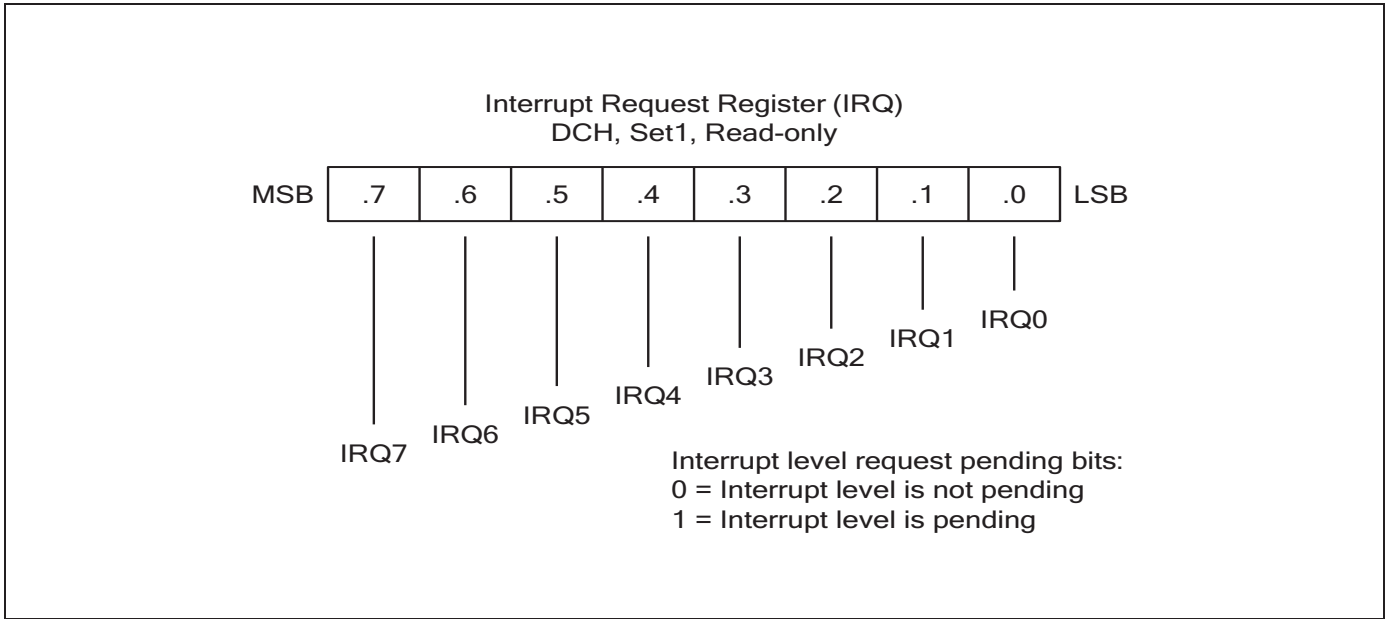
### 5.10 Interrupt Request Register (IRQ)

You can poll bit values in the interrupt request register, IRQ (DCH, Set1), to monitor interrupt request status for all levels in the interrupt structure of microcontroller. Each bit corresponds to the interrupt level of the same number: bit 0 to IRQ0, bit 1 to IRQ1, and so on. A "0" indicates that no interrupt request is currently being issued for that level. A "1" indicates that an interrupt request has been generated for that level.

IRQ bit values are read-only addressable using register addressing mode. You can read (test) the contents of the IRQ register at any time using bit or byte addressing to determine the current interrupt request status of specific interrupt levels. After a reset, all IRQ status bits are cleared to "0".

You can poll IRQ register values even if a DI instruction has been executed (that is, if global interrupt processing is disabled). When an interrupt occurs while the interrupt structure is disabled, the CPU will not service it. However you can, still detect the interrupt request by polling the IRQ register. In this way, you can determine which events occurred while the interrupt structure was globally disabled.

*Figure 5-9* illustrates the interrupt control register (IRQ).



**Figure 5-9** Interrupt Request Register (IRQ)

## 5.11 Interrupt Pending Function Types

This section includes:

- Overview
- Pending bits cleared automatically by hardware
- Pending bits cleared by the service routine

### 5.11.1 Overview

There are two types of interrupt pending bits:

- one type that is automatically cleared by hardware after the interrupt service routine is acknowledged and executed
- the other that must be cleared in the interrupt service routine

### 5.11.2 Pending Bits Cleared Automatically by Hardware

For interrupt pending bits that are cleared automatically by hardware, interrupt logic sets the corresponding pending bit to "1" when a request occurs. It then issues an IRQ pulse to inform the CPU that an interrupt is waiting to be serviced. The CPU acknowledges the interrupt source by sending an IACK, executes the service routine, and clears the pending bit to "0". This type of pending bit is not mapped and cannot, therefore, be read or written by application software.

In S3F8S19/F8S15 interrupt structure, Timer A, Timer 0, Timer 1, Timer 2 overflow interrupts, Timer B match interrupt and LVD interrupt belong to this category of interrupts in which pending bits can be cleared automatically by hardware.

### 5.11.3 Pending Bits Cleared by the Service Routine

The second type of pending bit is the one that should be cleared by program software. The service routine should clear the appropriate pending bit before a return-from-interrupt subroutine (IRET) occurs. To do this, a "0" must be written to the corresponding pending bit location in the mode of source or control register.

## 5.12 Interrupt Source Polling Sequence

The interrupt request polling and servicing sequence is:

1. A source generates an interrupt request by setting the interrupt request bit to "1".
2. The CPU polling procedure identifies a pending condition for that source.
3. The CPU verifies the interrupt level of source.
4. The CPU generates an interrupt acknowledge signal.
5. Interrupt logic determines the vector address of interrupt.
6. The service routine starts and the source's pending bit is cleared to "0" (by hardware or by software).
7. The CPU continues polling for interrupt requests.

### 5.12.1 Interrupt Service Routines

Before an interrupt request is serviced, the following conditions must be met:

- Interrupt processing must be globally enabled (EI, SYM.0 = "1")
- The interrupt level must be enabled (IMR register)
- The interrupt level should have the highest priority if more than one level is currently requesting service
- The interrupt must be enabled at the source of interrupt (peripheral control register)

When all the above conditions are met, the interrupt request is acknowledged at the end of the instruction cycle. The CPU then initiates an interrupt machine cycle that completes the processing sequence listed here:

1. Resets (clear to "0") the interrupt enable bit in the SYM register (SYM.0) to disable all subsequent interrupts.
2. Saves the program counter (PC) and status flags to the system stack.
3. Branches to the interrupt vector to fetch the address of the service routine.
4. Passes control to the interrupt service routine.

When the interrupt service routine is completed, the CPU issues an Interrupt Return (IRET). The IRET restores the PC and status flags, setting SYM.0 to "1". It allows the CPU to process the next interrupt request.

### 5.12.2 Generating Interrupt Vector Addresses

The interrupt vector area in the ROM (00H–FFH) contains the addresses of interrupt service routines that correspond to each level in the interrupt structure. Vectored interrupt processing follows this sequence:

1. Push the low-byte of program counter value to the stack.
2. Push the high-byte of program counter value to the stack.
3. Push the FLAG register values to the stack.
4. Fetch the high-byte address of service routine from the vector location.
5. Fetch the low-byte address of service routine from the vector location.
6. Branch to the service routine specified by the concatenated 16-bit vector address.

**NOTE:** A 16-bit vector address always begins at an even-numbered ROM address within the range of 00H–FFH.

### 5.12.3 Nesting of Vectored Interrupts

It is possible to nest a higher-priority interrupt request while it services a lower-priority request.

To do this, you should follow these steps:

1. Push the current 8-bit interrupt mask register (IMR) value to the stack (PUSH IMR).
2. Load the IMR register with a new mask value that enables only the higher priority interrupt.
3. Execute an EI instruction to enable interrupt processing (a higher priority interrupt will be processed if it occurs).
4. When the lower-priority interrupt service routine ends, execute DI, restore the IMR to its original value by returning the previous mask value from the stack (POP IMR).
5. Execute an IRET.

Depending on the application, you may be able to simplify the procedure above to some extent.

### 5.12.4 Instruction Pointer

The instruction pointer (IP) is adopted by all the S3C8/S3F8-series microcontrollers to control the optional high-speed interrupt processing feature called fast interrupts. The IP consists of register pair DAH and DBH. The names of IP registers are IPH (high byte, IP15–IP8) and IPL (low byte, IP7–IP0).



### 5.12.5 Fast Interrupt Processing

The feature called fast interrupt processing enables an interrupt within a given level to be completed in approximately 6 clock cycles rather than the usual 16 clock cycles. To select a specific interrupt level for fast interrupt processing, you should write the appropriate 3-bit value to SYM.4–SYM.2. Then, to enable fast interrupt processing for the selected level, you should set SYM.1 to "1".

Two other system registers support fast interrupt processing:

- The instruction pointer (IP) that contains the starting address of the service routine (and later used to swap the program counter)
- When a fast interrupt occurs, the contents of the FLAGS register are stored in an unmapped, dedicated register called FLAGS' ("FLAGS prime").

**NOTE:** For the S3F8S19/F8S15 microcontroller, the service routines for any one of the eight interrupt levels: IRQ0–IRQ7, can be selected for fast interrupt processing.

### 5.12.6 Procedure for Initiating Fast Interrupts

To initiate fast interrupt processing:

1. Load the start address of the service routine into the IP.
2. Load the interrupt level number (IRQn) into the fast interrupt selection field (SYM.4–SYM.2).
3. Write a "1" to the fast interrupt enable bit in the SYM register.

### 5.12.7 Fast Interrupt Service Routine

When an interrupt occurs in the level selected for fast interrupt processing, these events occur:

1. The contents of the instruction pointer and the PC are swapped.
2. The FLAG register values are written to the FLAGS' ("FLAGS prime") register.
3. The fast interrupt status bit in the FLAGS register is set.
4. The interrupt is serviced.
5. Assuming that the fast interrupt status bit is set, when the fast interrupt service routine ends, the instruction pointer and PC values are swapped back.
6. The content of FLAGS' ("FLAGS prime") is copied automatically back to the FLAGS register.
7. The fast interrupt status bit in FLAGS is cleared automatically.

### **5.12.8 Relationship to Interrupt Pending Bit Types**

As described previously, there are two types of interrupt pending bits: One type that is automatically cleared by hardware after the interrupt service routine is acknowledged and executed. The other that must be cleared by the application program's interrupt service routine. You can select fast interrupt processing for interrupts with either type of pending condition clear function - by hardware or by software.

### **5.13 Programming Guidelines**

The only way to enable/disable a fast interrupt is to set/clear the fast interrupt enable bit in the SYM register, SYM.1. Executing an EI or DI instruction globally enables or disables all interrupt processing, including fast interrupts. If you use fast interrupts, ensure to load the IP with a new start address when the fast interrupt service routine ends. Refer to IRET instruction in chapter 6 for more information.

# 6 Instruction Set

## 6.1 Overview

The SAM8RC instruction set supports large register files that are typical of most SAM8 microcontrollers. There are 78 instructions.

The powerful data manipulation capabilities and features of the instruction set are:

- Supports a full complement of 8-bit arithmetic and logic operations that includes multiplication and division
- No special I/O instructions (I/O control/data registers are mapped directly into the register file)
- Includes decimal adjustment in binary-coded decimal (BCD) operations
- 16-bit (word) data can be incremented and decremented
- Provides flexible instructions for bit addressing, rotate, and shift operations

### 6.1.1 Data Types

The SAM8 CPU performs operations on bits, bytes, BCD digits, and two-byte words. Bits in the register file can be set, cleared, complemented, and tested. Bits within a byte are numbered from 7 to 0, where bit 0 is the least significant (right-most) bit.

### 6.1.2 Register Addressing

To access an individual register, an 8-bit address in the range 0-255 or the 4-bit address of a working register is specified. Paired registers can be used to construct 16-bit data or 16-bit program memory or data memory addresses. Refer to Chapter 2 "Address Spaces" for more information about register addressing.

### 6.1.3 Addressing Modes

There are seven explicit addressing modes, namely:

- Register (R)
- Indirect Register (IR)
- Indexed (X)
- Direct (DA)
- Relative (RA)
- Immediate (IM)
- Indirect (IA)

Refer to Chapter 3 "Addressing Modes" for more information on these addressing modes.

Figure 6-1 describes the Instruction Group summary.

**Table 6-1 Instruction Group Summary**

| Mnemonic                       | Operands | Instruction                                  |
|--------------------------------|----------|--|
| <b>Load Instructions</b>       |          |  |
| CLR                            | dst      | Clear  |
| LD                             | dst, src | Load   |
| LDB                            | dst, src | Load bit                                     |
| LDE                            | dst, src | Load external data memory                    |
| LDC                            | dst, src | Load program memory                          |
| LDED                           | dst, src | Load external data memory and decrement      |
| LDCD                           | dst, src | Load program memory and decrement            |
| LDEI                           | dst, src | Load external data memory and increment      |
| LDCI                           | dst, src | Load program memory and increment            |
| LDEPD                          | dst, src | Load external data memory with pre-decrement |
| LDCPD                          | dst, src | Load program memory with pre-decrement       |
| LDEPI                          | dst, src | Load external data memory with pre-increment |
| LDCPI                          | dst, src | Load program memory with pre-increment       |
| LDW                            | dst, src | Load word                                    |
| POP                            | dst      | Pop from stack                               |
| POPUD                          | dst, src | Pop user stack (Decrementing)                |
| POPUI                          | dst, src | Pop user stack (Incrementing)                |
| PUSH                           | Src      | Push to stack                                |
| PUSHUD                         | dst, src | Push user stack (Decrementing)               |
| PUSHUI                         | dst, src | Push user stack (Incrementing)               |
| <b>Arithmetic Instructions</b> |          |  |
| ADC                            | dst, src | Add with carry                               |
| ADD                            | dst, src | Add  |
| CP                             | dst, src | Compare                                      |
| DA                             | dst      | Decimal adjust                               |
| DEC                            | dst      | Decrement                                    |
| DECW                           | dst      | Decrement word                               |
| DIV                            | dst, src | Divide                                       |
| INC                            | dst      | Increment                                    |
| INCW                           | dst      | Increment word                               |
| MULT                           | dst, src | Multiply                                     |
| SBC                            | dst, src | Subtract with carry                          |
| SUB                            | dst, src | Subtract                                     |

| Mnemonic                             | Operands | Instruction                              |
|--------------------------------------|----------|--|
| <b>Logic Instructions</b>            |          |  |
| AND                                  | dst, src | Logical AND                              |
| COM                                  | dst      | Complement                               |
| OR                                   | dst, src | Logical OR                               |
| XOR                                  | dst, src | Logical exclusive OR                     |
| <b>Program Control Instructions</b>  |          |  |
| BTJRF                                | dst, src | Bit test and jump relative on false      |
| BTJRT                                | dst, src | Bit test and jump relative on true       |
| CALL                                 | dst      | Call procedure                           |
| CPIJE                                | dst, src | Compare, increment and jump on equal     |
| CPIJNE                               | dst, src | Compare, increment and jump on non-equal |
| DJNZ                                 | r, dst   | Decrement register and jump on non-zero  |
| ENTER                                | –        | Enter                                    |
| EXIT                                 | –        | Exit                                     |
| IRET                                 | –        | Interrupt return                         |
| JP                                   | cc, dst  | Jump on condition code                   |
| JP                                   | dst      | Jump unconditional                       |
| JR                                   | cc, dst  | Jump relative on condition code          |
| NEXT                                 | –        | Next                                     |
| RET                                  | –        | Return                                   |
| WFI                                  | –        | Wait for interrupt                       |
| <b>Bit Manipulation Instructions</b> |          |  |
| BAND                                 | dst, src | Bit AND                                  |
| BCP                                  | dst, src | Bit compare                              |
| BITC                                 | dst      | Bit complement                           |
| BITR                                 | dst      | Bit reset                                |
| BITS                                 | dst      | Bit set                                  |
| BOR                                  | dst, src | Bit OR                                   |
| BXOR                                 | dst, src | Bit XOR                                  |
| TCM                                  | dst, src | Test complement under mask               |
| TM                                   | dst, src | Test under mask                          |
| <b>Rotate and Shift Instructions</b> |          |  |
| RL                                   | dst      | Rotate left                              |
| RLC                                  | dst      | Rotate left through carry                |
| RR                                   | dst      | Rotate right                             |
| RRC                                  | dst      | Rotate right through carry               |
| SRA                                  | dst      | Shift right arithmetic                   |

| Mnemonic                        | Operands | Instruction            |
|---------------------------------|----------|------------------------|
| SWAP                            | dst      | Swap nibbles           |
| <b>CPU Control Instructions</b> |          |                        |
| CCF                             | –        | Complement carry flag  |
| DI                              | –        | Disable interrupts     |
| EI                              | –        | Enable interrupts      |
| IDLE                            | –        | Enter Idle mode        |
| NOP                             | –        | No operation           |
| RCF                             | –        | Reset carry flag       |
| SB0                             | –        | Set bank 0             |
| SB1                             | –        | Set bank 1             |
| SCF                             | –        | Set carry flag         |
| SRP                             | src      | Set register pointers  |
| SRP0                            | src      | Set register pointer 0 |
| SRP1                            | src      | Set register pointer 1 |
| STOP                            | –        | Enter Stop mode        |

### 6.2 Flags Register

The flags register (FLAGS) contains 8 bits that describe the current status of CPU operations. Four of these bits, FLAGS.7–FLAGS.4, can be tested and used with conditional jump instructions; two others FLAGS.3 and FLAGS.2 are used for BCD arithmetic.

FLAGS also contain a bit to indicate the status of fast interrupt processing (FLAGS.1) and a bank address status bit (FLAGS.0) to indicate whether bank 0 or bank 1 is currently being addressed. FLAGS can be set or reset by instructions as long as its outcome does not affect the FLAGS, such as, Load instruction.

Logical and arithmetic instructions such as, AND, OR, XOR, ADD, and SUB can affect the FLAGS. For example, the AND instruction updates the Zero, Sign and Overflow flags on the basis of outcome of the AND instruction. When the AND instruction uses the FLAGS as the destination, two writes occur simultaneously to the FLAGS that produces an unpredictable result.

Figure 6-1 illustrates the system Flags register (FLAGS).

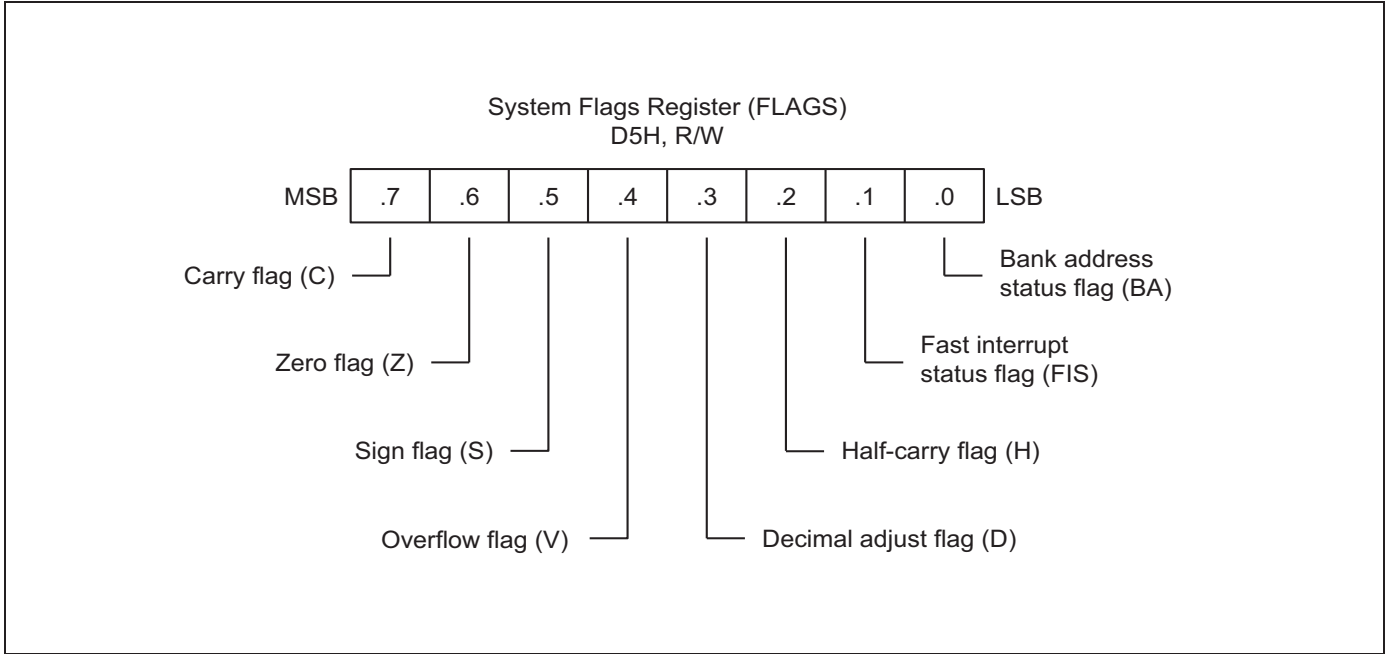


Figure 6-1 System Flags Register (FLAGS)

## 6.3 Flag Descriptions

### Carry Flag (FLAGS.7)

- C** The C flag is set to "1" when the result from an arithmetic operation generates carry-out from or borrow to the bit 7 position (MSB). After rotate and shift operations, it contains the last value shifted out of the specified register. Program instructions can set, clear, or complement the carry flag.

### Zero Flag (FLAGS.6)

- Z** For arithmetic and logic operations, the Z flag is set to "1" if the result of the operation is zero. For operations that test register bits, and for shift and rotate operations, the Z flag is set to "1" when the result is logic zero.

### Sign Flag (FLAGS.5)

- S** Following arithmetic, logic, rotate, or shift operations, the sign bit identifies the state of the MSB of the result. A logic zero indicates a positive number and a logic one indicates a negative number.

### Overflow Flag (FLAGS.4)

- V** The V flag is set to "1" when the result of a two's-complement operation is greater than + 127 or less than -128. It also clears to "0" following logic operations.

### Decimal Adjust Flag (FLAGS.3)

- D** The DA bit is used to specify what type of instruction that it executed last during BCD operations so that a subsequent decimal adjust operation can execute correctly. Usually, programmers cannot access DA and cannot use as a test condition.

### Half-Carry Flag (FLAGS.2)

- H** The H bit is set to "1" whenever an addition generates a carry-out of bit 3, or when a subtraction borrows out of bit 4. It is used by the Decimal Adjust (DA) instruction to convert the binary result of a previous addition or subtraction into the correct decimal (BCD) result. A program seldom accesses the H flag.

### Fast Interrupt Status Flag (FLAGS.1)

- FIS** The FIS bit is set during a fast interrupt cycle and resets during the Interrupt Return (IRET) following interrupt servicing. When set, it inhibits all interrupts and causes the fast interrupt return to be executed when the IRET instruction is executed.

### Bank Address Flag (FLAGS.0)

- BA** The BA flag indicates which register bank it currently selects in the set 1 area of the internal register file, bank 0 or bank 1. The BA flag is cleared to "0" (select bank 0) when you execute the SB0 instruction and is set to "1" (select bank 1) when you execute the SB1 instruction.



## 6.4 Instruction Set Notation

[Table 6-2](#) describes the Flag Notation conventions.

**Table 6-2 Flag Notation Conventions**

| Flag | Description                           |
|------|---------------------------------------|
| C    | Carry flag                            |
| Z    | Zero flag                             |
| S    | Sign flag                             |
| V    | Overflow flag                         |
| D    | Decimal-adjust flag                   |
| H    | Half-carry flag                       |
| 0    | Cleared to logic zero                 |
| 1    | Set to logic one                      |
| *    | Set or cleared according to operation |
| –    | Value is unaffected                   |
| x    | Value is undefined                    |

[Table 6-3](#) describes the Instruction Set symbols.

**Table 6-3 Instruction Set Symbols**

| Symbol | Description                                  |
|--------|--|
| dst    | Destination operand                          |
| src    | Source operand                               |
| @      | Indirect register address prefix             |
| PC     | Program counter                              |
| IP     | Instruction pointer                          |
| FLAGS  | Flags register (D5H)                         |
| RP     | Register pointer                             |
| #      | Immediate operand or register address prefix |
| H      | Hexadecimal number suffix                    |
| D      | Decimal number suffix                        |
| B      | Binary number suffix                         |
| opc    | Opcode                                       |

[Table 6-4](#) describes the Instruction Notation conventions.

**Table 6-4 Instruction Notation Conventions**

| Notation | Description  | Actual Operand Range   |
|----------|--|--|
| cc       | Condition code   | Refer to the list of condition codes in <a href="#">Table 6-7</a> for more information.                            |
| r        | Working register only                                    | Rn (n = 0–15)  |
| rb       | Bit (b) of working register                              | Rn.b (n = 0–15, b = 0–7)   |
| r0       | Bit 0 (LSB) of working register                          | Rn (n = 0–15)  |
| rr       | Working register pair                                    | RRp (p = 0, 2, 4, ..., 14)   |
| R        | Register or working register                             | reg or Rn (reg = 0–255, n = 0–15)  |
| Rb       | Bit "b" of register or working register                  | reg.b (reg = 0–255, b = 0–7)   |
| RR       | Register pair or working register pair                   | reg or RRp (reg = 0–254, even number only, where p = 0, 2, ..., 14)  |
| IA       | Indirect addressing mode                                 | addr (addr = 0–254, even number only)  |
| Ir       | Indirect working register only                           | @ Rn (n = 0–15)  |
| IR       | Indirect register or indirect working register           | @ Rn or @ reg (reg = 0–255, n = 0–15)  |
| Irr      | Indirect working register pair only                      | @ RRp (p = 0, 2, ..., 14)  |
| IRR      | Indirect register pair or indirect working register pair | @ RRp or @ reg (reg = 0–254, even only, where p = 0, 2, ..., 14)   |
| X        | Indexed addressing mode                                  | # reg [Rn] (reg = 0–255, n = 0–15)   |
| XS       | Indexed (short offset) addressing mode                   | # addr [RRp] (addr = range –128 to +127, where p = 0, 2, ..., 14)  |
| xl       | Indexed (long offset) addressing mode                    | # addr [RRp] (addr = range 0–65535, where p = 0, 2, ..., 14)   |
| da       | Direct addressing mode                                   | addr (addr = range 0–65535)  |
| ra       | Relative addressing mode                                 | addr (addr = number in the range + 127 to – 128 that is an offset relative to the address of the next instruction) |
| im       | Immediate addressing mode                                | # data (data = 0–255)  |
| iml      | Immediate (long) addressing mode                         | # data (data = range 0–65535)  |

Table 6-5 lists the Opcode quick reference (0–7).

Table 6-5 Opcode Quick Reference (0–7)

| OPCODE Map         |   |             |               |                       |                   |                 |                  |                 |                     |
|--------------------|---|-------------|---------------|-----------------------|-------------------|-----------------|------------------|-----------------|---------------------|
| Lower Nibble (Hex) |   |             |               |                       |                   |                 |                  |                 |                     |
| –                  | – | 0           | 1             | 2                     | 3                 | 4               | 5                | 6               | 7                   |
| U                  | 0 | DEC<br>R1   | DEC<br>IR1    | ADD<br>r1, r2         | ADD<br>r1, lrr2   | ADD<br>R2, R1   | ADD<br>IR2, R1   | ADD<br>R1, IM   | BOR<br>r0–Rb        |
| P                  | 1 | RLC<br>R1   | RLC<br>IR1    | ADC<br>r1, r2         | ADC<br>r1, lrr2   | ADC<br>R2, R1   | ADC<br>IR2, R1   | ADC<br>R1, IM   | BCP<br>r1.b, R2     |
| P                  | 2 | INC<br>R1   | INC<br>IR1    | SUB<br>r1, r2         | SUB<br>r1, lrr2   | SUB<br>R2, R1   | SUB<br>IR2, R1   | SUB<br>R1, IM   | BXOR<br>r0–Rb       |
| E                  | 3 | JP<br>IRR1  | SRP/0/1<br>IM | SBC<br>r1, r2         | SBC<br>r1, lrr2   | SBC<br>R2, R1   | SBC<br>IR2, R1   | SBC<br>R1, IM   | BTJR<br>r2.b, RA    |
| R                  | 4 | DA<br>R1    | DA<br>IR1     | OR<br>r1, r2          | OR<br>r1, lrr2    | OR<br>R2, R1    | OR<br>IR2, R1    | OR<br>R1, IM    | LDB<br>r0–Rb        |
| –                  | 5 | POP<br>R1   | POP<br>IR1    | AND<br>r1, r2         | AND<br>r1, lrr2   | AND<br>R2, R1   | AND<br>IR2, R1   | AND<br>R1, IM   | BITC<br>r1.b        |
| N                  | 6 | COM<br>R1   | COM<br>IR1    | TCM<br>r1, r2         | TCM<br>r1, lrr2   | TCM<br>R2, R1   | TCM<br>IR2, R1   | TCM<br>R1, IM   | BAND<br>r0–Rb       |
| I                  | 7 | PUSH<br>R2  | PUSH<br>IR2   | TM<br>r1, r2          | TM<br>r1, lrr2    | TM<br>R2, R1    | TM<br>IR2, R1    | TM<br>R1, IM    | BIT<br>r1.b         |
| B                  | 8 | DECW<br>RR1 | DECW<br>IR1   | PUSHUD<br>IR1, R2     | PUSHUI<br>IR1, R2 | MULT<br>R2, RR1 | MULT<br>IR2, RR1 | MULT<br>IM, RR1 | LD<br>r1, x, r2     |
| B                  | 9 | RL<br>R1    | RL<br>IR1     | POPUD<br>IR2, R1      | POPUI<br>IR2, R1  | DIV<br>R2, RR1  | DIV<br>IR2, RR1  | DIV<br>IM, RR1  | LD<br>r2, x, r1     |
| L                  | A | INCW<br>RR1 | INCW<br>IR1   | CP<br>r1, r2          | CP<br>r1, lrr2    | CP<br>R2, R1    | CP<br>IR2, R1    | CP<br>R1, IM    | LDC<br>r1, lrr2, xL |
| E                  | B | CLR<br>R1   | CLR<br>IR1    | XOR<br>r1, r2         | XOR<br>r1, lrr2   | XOR<br>R2, R1   | XOR<br>IR2, R1   | XOR<br>R1, IM   | LDC<br>r2, lrr2, xL |
| –                  | C | RRC<br>R1   | RRC<br>IR1    | CPIJE<br>lr, r2, RA   | LDC<br>r1, lrr2   | LDW<br>RR2, RR1 | LDW<br>IR2, RR1  | LDW<br>RR1, IML | LD<br>r1, lrr2      |
| H                  | D | SRA<br>R1   | SRA<br>IR1    | CPIJNE<br>lrr, r2, RA | LDC<br>r2, lrr1   | CALL<br>IA1     | –                | LD<br>IR1, IM   | LD<br>lrr1, r2      |
| E                  | E | RR<br>R1    | RR<br>IR1     | LDCD<br>r1, lrr2      | LDCI<br>r1, lrr2  | LD<br>R2, R1    | LD<br>R2, IR1    | LD<br>R1, IM    | LDC<br>r1, lrr2, xs |
| X                  | F | SWAP<br>R1  | SWAP<br>IR1   | LDCPD<br>r2, lrr1     | LDCPI<br>r2, lrr1 | CALL<br>IRR1    | LD<br>IR2, R1    | CALL<br>DA1     | LDC<br>r2, lrr1, xs |

Table 6-6 lists the Opcode Quick references (8–F).

Table 6-6 Opcode Quick Reference (8–F)

| OPCODE Map         |   |              |              |                |              |              |              |           |       |
|--------------------|---|--------------|--------------|----------------|--------------|--------------|--------------|-----------|-------|
| Lower Nibble (Hex) |   |              |              |                |              |              |              |           |       |
| –                  | – | 8            | 9            | A              | B            | C            | D            | E         | F     |
| U                  | 0 | LD<br>r1, R2 | LD<br>r2, R1 | DJNZ<br>r1, RA | JR<br>cc, RA | LD<br>r1, IM | JP<br>cc, DA | INC<br>r1 | NEXT  |
| P                  | 1 | ↓            | ↓            | ↓              | ↓            | ↓            | ↓            | ↓         | ENTER |
| P                  | 2 | –            | –            | –              | –            | –            | –            | –         | EXIT  |
| E                  | 3 | –            | –            | –              | –            | –            | –            | –         | WFI   |
| R                  | 4 | –            | –            | –              | –            | –            | –            | –         | SB0   |
|                    | 5 | –            | –            | –              | –            | –            | –            | –         | SB1   |
| N                  | 6 | –            | –            | –              | –            | –            | –            | –         | IDLE  |
| I                  | 7 | ↓            | ↓            | ↓              | ↓            | ↓            | ↓            | ↓         | STOP  |
| B                  | 8 | –            | –            | –              | –            | –            | –            | –         | DI    |
| B                  | 9 | –            | –            | –              | –            | –            | –            | –         | EI    |
| L                  | A | –            | –            | –              | –            | –            | –            | –         | RET   |
| E                  | B | –            | –            | –              | –            | –            | –            | –         | IRET  |
|                    | C | –            | –            | –              | –            | –            | –            | –         | RCF   |
| H                  | D | ↓            | ↓            | ↓              | ↓            | ↓            | ↓            | ↓         | SCF   |
| E                  | E | –            | –            | –              | –            | –            | –            | –         | CCF   |
| X                  | F | LD<br>r1, R2 | LD<br>r2, R1 | DJNZ<br>r1, RA | JR<br>cc, RA | LD<br>r1, IM | JP<br>cc, DA | INC<br>r1 | NOP   |

## 6.5 Condition Codes

The opcode of a conditional jump always contains a 4-bit field called the condition code (cc). This specifies under which conditions it is to execute the jump. For example, a conditional jump with the condition code for "equal" after a compare operation only jumps if the two operands are equal.

The carry (C), zero (Z), sign (S) and overflow (V) flags are used to control the operation of conditional jump instructions.

[Table 6-7](#) describes the conditional codes.

**Table 6-7 Condition Codes**

| Binary      | Mnemonic | Description                    | Flags Set             |
|-------------|----------|--------------------------------|-----------------------|
| 0000        | F        | Always false                   | –                     |
| 1000        | T        | Always true                    | –                     |
| 0111 (NOTE) | C        | Carry                          | C = 1                 |
| 1111 (NOTE) | NC       | No carry                       | C = 0                 |
| 0110 (NOTE) | Z        | Zero                           | Z = 1                 |
| 1110 (NOTE) | NZ       | Not zero                       | Z = 0                 |
| 1101        | PL       | Plus                           | S = 0                 |
| 0101        | MI       | Minus                          | S = 1                 |
| 0100        | OV       | Overflow                       | V = 1                 |
| 1100        | NOV      | No overflow                    | V = 0                 |
| 0110 (NOTE) | EQ       | Equal                          | Z = 1                 |
| 1110 (NOTE) | NE       | Not equal                      | Z = 0                 |
| 1001        | GE       | Greater than or equal          | (S XOR V) = 0         |
| 0001        | LT       | Less than                      | (S XOR V) = 1         |
| 1010        | GT       | Greater than                   | (Z OR (S XOR V)) = 0  |
| 0010        | LE       | Less than or equal             | (Z OR (S XOR V)) = 1  |
| 1111 (NOTE) | UGE      | Unsigned greater than or equal | C = 0                 |
| 0111 (NOTE) | ULT      | Unsigned less than             | C = 1                 |
| 1011        | UGT      | Unsigned greater than          | (C = 0 AND Z = 0) = 1 |
| 0011        | ULE      | Unsigned less than or equal    | (C OR Z) = 1          |

### NOTE:

1. It indicates condition codes that are related to two different mnemonics but that tests the same flag. For example, Z and EQ are true if the zero flag (Z) is set, but after an ADD instruction, Z may be used; after a CP instruction, however, EQ may be used.
2. For operations involving unsigned numbers, the special condition codes UGE, ULT, UGT, and ULE must be used.

## 6.6 Instruction Descriptions

This section describes information and programming examples for each instruction in the SAM8 instruction set. It arranges information in a consistent format for improved readability and for fast referencing.

It includes the information listed in each instruction description:

- Instruction name (mnemonic)
- Full instruction name
- Source/destination format of the instruction operand
- Shorthand notation of the operation of information
- Textual description of the effect of instruction
- Specific flag settings affected by the instruction
- Detailed description of the format of instruction, execution time, and addressing mode(s)
- Programming example(s) that explains how to use the instruction

### 6.6.1 ADC-Add with Carry

**ADC** dst, src

**Operation:**  $dst \leftarrow dst + src + c$

The source operand, along with the setting of the carry flag, is added to the destination operand and the sum is stored in the destination. The contents of the source are unaffected. Two's-complement addition is performed. In multiple precision arithmetic, this instruction permits the carry from the addition of low-order operands to be carried into the addition of high-order operands.

- Flags:**
- C:** Sets if there is a carry from the most significant bit of the result; otherwise it clears.
  - Z:** Sets if the result is "0"; otherwise it clears.
  - S:** Sets if the result is negative; otherwise it clears.
  - V:** Sets if arithmetic overflow occurs, that is, if both operands are of the same sign and the result is of the opposite sign; otherwise it clears.
  - D:** Always clears to "0".
  - H:** Sets if there is a carry from the most significant bit of the low-order four bits of the result; otherwise it clears.

**Format:**

|     |           | Bytes | Cycles | Opcode<br>(Hex) | Addr Mode<br>dst | src |
|-----|-----------|-------|--------|-----------------|------------------|-----|
| opc | dst   src | 2     | 4      | 12              | r                | r   |
|     |           |       | 6      | 13              | r                | lr  |
| opc | src       | dst   | 3      | 6               | R                | R   |
|     |           |       |        | 6               | 15               | R   |
| opc | dst       | src   | 3      | 6               | R                | IM  |

**Examples:** Given: R1 = 10H, R2 = 03H, C flag = "1", register 01H = 20H, register 02H = 03H, and register 03H = 0AH:

```

ADC   R1, R2      →   R1 = 14H, R2 = 03H
ADC   R1, @R2     →   R1 = 1BH, R2 = 03H
ADC   01H, 02H    →   Register 01H = 24H, register 02H = 03H
ADC   01H, @02H   →   Register 01H = 2BH, register 02H = 03H
ADC   01H, #11H   →   Register 01H = 32H
    
```

In the first example, destination register R1 contains the value 10H, the carry flag is set to "1", and the source working register R2 contains the value 03H. The statement "ADC R1, R2" adds 03H and the carry flag value ("1") to the destination value 10H by leaving 14H in register R1.

### 6.6.2 ADD-Add

**ADD** dst, src

**Operation:** dst ← dst + src

The source operand is added to the destination operand and the sum is stored in the destination. The contents of the source are unaffected. Two's-complement addition is performed.

- Flags:**
- C:** Sets if there is a carry from the most significant bit of the result; cleared otherwise.
  - Z:** Sets if the result is "0"; cleared otherwise.
  - S:** Sets if the result is negative; cleared otherwise.
  - V:** Sets if arithmetic overflow occurs, that is, if both operands are of the same sign and the result is of the opposite sign; cleared otherwise.
  - D:** Always cleared to "0".
  - H:** Sets if a carry from the low-order nibble occurs.

**Format:**

|     |           | Bytes | Cycles | Opcode (Hex) | Addr Mode | dst | src |
|-----|-----------|-------|--------|--------------|-----------|-----|-----|
| opc | dst   src | 2     | 4      | 02           | r         | r   |     |
|     |           |       | 6      | 03           | r         | lr  |     |
| opc | src       | 3     | 6      | 04           | R         | R   |     |
|     |           |       | 6      | 05           | R         | IR  |     |
| opc | dst       | 3     | 6      | 06           | R         |     | IM  |

**Examples:** Given: R1 = 12H, R2 = 03H, register 01H = 21H, register 02H = 03H, register 03H = 0AH:

```

ADD R1, R2      → R1 = 15H, R2 = 03H
ADD R1, @R2     → R1 = 1CH, R2 = 03H
ADD 01H, 02H   → Register 01H = 24H, register 02H = 03H
ADD 01H, @02H  → Register 01H = 2BH, register 02H = 03H
ADD 01H, #25H  → Register 01H = 46H
    
```

In the first example, destination working register R1 contains 12H and the source working register R2 contains 03H. The statement "ADD R1, R2" adds 03H to 12H by leaving the value 15H in register R1.



### 6.6.3 AND-Logical AND

**AND** dst, src

**Operation:** dst ← dst AND src

The source operand is logically ANDed with the destination operand. The result is stored in the destination. The AND operation results in a "1" bit being stored whenever the corresponding bits in the two operands are both logic ones; otherwise a "0" bit value is stored. The contents of the source are unaffected.

- Flags:**
- C:** Does not affect.
  - Z:** Sets if the result is "0"; cleared otherwise.
  - S:** Sets if the result bit 7 is set; cleared otherwise.
  - V:** Always cleared to "0".
  - D:** Does not affect.
  - H:** Does not affect.

**Format:**

|     |           | Bytes | Cycles | Opcode<br>(Hex) | Addr Mode<br>dst | src |
|-----|-----------|-------|--------|-----------------|------------------|-----|
| opc | dst   src | 2     | 4      | 52              | r                | r   |
|     |           |       | 6      | 53              | r                | lr  |
| opc | src       | 3     | 6      | 54              | R                | R   |
|     |           |       | 6      | 55              | R                | IR  |
| opc | dst       | 3     | 6      | 56              | R                | IM  |

**Examples:** Given: R1 = 12H, R2 = 03H, register 01H = 21H, register 02H = 03H, register 03H = 0AH:

- AND R1, R2 → R1 = 02H, R2 = 03H
- AND R1, @R2 → R1 = 02H, R2 = 03H
- AND 01H, 02H → Register 01H = 01H, register 02H = 03H
- AND 01H, @02H → Register 01H = 00H, register 02H = 03H
- AND 01H, #25H → Register 01H = 21H

In the first example, destination working register R1 contains the value 12H and the source working register R2 contains 03H. The statement "AND R1, R2" logically ANDs the source operand 03H with the destination operand value 12H by leaving the value 02H in register R1.

### 6.6.4 BAND-Bit AND

**BAND** dst, src.b

**BAND** dst.b, src

**Operation:** dst (0) ← dst (0) AND src (b)  
or  
dst (b) ← dst (b) AND src (0)

The specified bit of the source (or the destination) is logically ANDed with the zero bit (LSB) of the destination (or source). The resultant bit is stored in the specified bit of the destination. No other bits of the destination are affected. The source is unaffected.

- Flags:**
- C:** Does not affect.
  - Z:** Set if the result is "0"; cleared otherwise.
  - S:** Clears to "0".
  - V:** Does not define.
  - D:** Does not define.
  - H:** Does not define.

**Format:**

|     |             |     | Bytes | Cycles | Opcode<br>(Hex) | Addr Mode<br>dst src |
|-----|-------------|-----|-------|--------|-----------------|----------------------|
| opc | dst   b   0 | src | 3     | 6      | 67              | r0 Rb                |
| opc | src   b   1 | dst | 3     | 6      | 67              | Rb r0                |

**NOTE:** In the second byte of the 3 byte instruction formats, the destination (or source) address is 4 bits, the bit address "b" is 3 bits, and the LSB address value is 1 bit in length.

**Examples:** Given: R1 = 07H and register 01H = 05H:

BAND R1, 01H.1 → R1 = 06H, register 01H = 05H  
 BAND 01H.1, R1 → Register 01H = 05H, R1 = 07H

In the first example, source register 01H contains the value 05H (00000101B) and destination working register R1 contains 07H (00000111B). The statement "BAND R1, 01H.1" ANDs the bit 1 value of the source register ("0") with the bit 0 value of register R1 (destination) by leaving the value 06H (00000110B) in register R1.

### 6.6.5 BCP-Bit Compare

**BCP** dst, src.b

**Operation:** dst (0)-src (b)

The specified bit of the source is compared to (subtracts from) bit zero (LSB) of the destination. The zero flag is set when the bits are the same; otherwise it clears. The comparison does not affect the contents of both operands.

- Flags:**
- C:** Does not affect.
  - Z:** Sets if two bits are similar; otherwise it clears.
  - S:** Clears to "0".
  - V:** Does not define.
  - D:** Does not define.
  - H:** Does not define.

**Format:**

|     |             |     | Bytes | Cycles | Opcode<br>(Hex) | Addr Mode<br>dst src |
|-----|-------------|-----|-------|--------|-----------------|----------------------|
| opc | dst   b   0 | src | 3     | 6      | 17              | r0 Rb                |

**NOTE:** In the second byte of the instruction format, the destination address is 4 bits, the bit address "b" is 3 bits, and the LSB address value is 1 bit in length.

**Example:** Given: R1 = 07H and register 01H = 01H:

BCP R1, 01H.1 → R1 = 07H, register 01H = 01H

If destination working register R1 contains the value 07H (00000111B) and the source register 01H contains the value 01H (00000001B), the statement "BCP R1, 01H.1" compares 1 one of the source register (01H) and bit 0 of the destination register (R1). As the bit values are not identical, the zero flag bit (Z) is cleared in the FLAGS (0D5H).

### 6.6.6 BITC-Bit Complement

**BITC**            dst.b

**Operation:**    dst (b) ← NOT dst (b)

This instruction complements the specified bit within the destination without affecting any other bits in the destination.

- Flags:**
- C:**     Does not affect.
  - Z:**     Sets if the result is "0"; Otherwise clears.
  - S:**     Clears to "0".
  - V:**     Does not define.
  - D:**     Does not define.
  - H:**     Does not define.

**Format:**

|     |             | Bytes | Cycles | Opcode<br>(Hex) | Addr Mode<br>dst |
|-----|-------------|-------|--------|-----------------|------------------|
| opc | dst   b   0 | 2     | 4      | 57              | rb               |

**NOTE:** In the second byte of the instruction format, the destination address is 4 bits, the bit address "b" is 3 bits, and the LSB address value is 1 bit in length.

**Example:**     Given: R1 = 07H

BITC    R1.1    →     R1 = 05H

If working register R1 contains the value 07H (00000111B), the statement "BITC R1.1" complements bit one of the destination and leaves the value 05H (00000101B) in register R1. Because the result of the complement is not "0", the zero flag (Z) in the FLAGS (0D5H) is cleared.

### 6.6.7 BITR-Bit Reset

**BITR** dst.b

**Operation:** dst (b) ← 0

The BITR instruction clears the specified bit within the destination without affecting any other bits in the destination.

**Flags:** Does not affect .

**Format:**

|     |             | Bytes | Cycles | Opcode<br>(Hex) | Addr Mode |
|-----|-------------|-------|--------|-----------------|-----------|
| opc | dst   b   0 | 2     | 4      | 77              | dst<br>rb |

**NOTE:** In the second byte of the instruction format, the destination address is 4 bits, the bit address "b" is 3 bits, and the LSB address value is 1 bit in length.

**Example:** Given: R1 = 07H:

BITR R1.1 → R1 = 05H

When the value of working register R1 is 07H (00000111B), the statement "BITR R1.1" clears bit1 of the destination register R1 by leaving the value 05H (00000101B).

### 6.6.8 BITS-Bit Set

**BITS** dst.b

**Operation:** dst (b) ← 1

The BITS instruction sets the specified bit within the destination without affecting any other bits in the destination.

**Flags:** No flags are affected.

**Format:**

|     |             | Bytes | Cycles | Opcode<br>(Hex) | Addr Mode |
|-----|-------------|-------|--------|-----------------|-----------|
|     |             |       |        |                 | dst       |
| opc | dst   b   1 | 2     | 4      | 77              | rb        |

**NOTE:** In the second byte of the instruction format, the destination address is 4 bits, the bit address "b" is 3 bits, and the LSB address value is 1 bit in length.

**Example:** Given: R1 = 07H:

`BITS R1.3 → R1 = 0FH`

If working register R1 contains the value 07H (00000111B), the statement "BITS R1.3" sets bit 3 of the destination register R1 to "1" by leaving the value 0FH (00001111B).

### 6.6.9 BOR-Bit OR

**BOR** dst, src.b

**BOR** dst.b,src

**Operation:** dst (0) ← dst (0) OR src (b)

or

dst (b) ← dst (b) OR src (0)

The specified bit of the source (or the destination) is logically ORed with bit zero (LSB) of the destination (or the source). The resulting bit value is stored in the specified bit of the destination. No other bits of the destination are affected. The source is unaffected.

- Flags:**
- C:** Does not affect.
  - Z:** Sets if the result is "0"; otherwise it clears.
  - S:** Clears to "0".
  - V:** Does not affect.
  - D:** Does not affect.
  - H:** Does not affect.

#### Format:

|     |             |     | Bytes | Cycles | Opcode<br>(Hex) | Addr Mode<br>dst | src |
|-----|-------------|-----|-------|--------|-----------------|------------------|-----|
| opc | dst   b   0 | src | 3     | 6      | 07              | r0               | Rb  |
| opc | src   b   1 | dst | 3     | 6      | 07              | Rb               | r0  |

**NOTE:** In the second byte of the 3 byte instruction formats, the destination (or source) address is 4 bits, the bit address "b" is 3 bits, and the LSB address value is 1 bit.

**Examples:** Given: R1 = 07H and register 01H = 03H:

```
BOR R1, 01H.1 → R1 = 07H, register 01H = 03H
BOR 01H.2, R1 → Register 01H = 07H, R1 = 07H
```

In the first example, destination working register R1 contains the value 07H (00000111B) and source register 01H the value 03H (00000011B). The statement "BOR R1, 01H.1" logically ORs bit 1 of register 01H (source) with bit 0 of R1 (destination). This leaves the same value (07H) in working register R1.

In the second example, destination register 01H contains the value 03H (00000011B) and the source working register R1 the value 07H (00000111B). The statement "BOR 01H.2, R1" logically ORs bit 2 of register 01H (destination) with bit 0 of R1 (source). This leaves the value 07H in register 01H.

### 6.6.10 BTJRF-Bit Test, Jump Relative on False

**BTJRF** dst, src.b

**Operation:** If src (b) is a "0", then  $PC \leftarrow PC + dst$

The specified bit within the source operand is tested. If it is a "0", the relative address is added to the program counter and control passes to the statement whose address is now in the PC; otherwise, the instruction following the BTJRF instruction is executed.

**Flags:** Does not affect any flags.

**Format:**

| (NOTE) |             |     | Bytes | Cycles | Opcode<br>(Hex) | Addr Mode<br>dst | src |
|--------|-------------|-----|-------|--------|-----------------|------------------|-----|
| opc    | src   b   0 | dst | 3     | 10     | 37              | RA               | rb  |

**NOTE:** In the second byte of the instruction format, the source address is 4 bits, the bit address "b" is 3 bits, and the LSB address value is 1 bit in length.

**Example:** Given: R1 = 07H:

```
BTJRF SKIP, R1.3 → PC jumps to SKIP location
```

If working register R1 contains the value 07H (00000111B), the statement "BTJRF SKIP, R1.3" tests bit 3. As it is "0", the relative address is added to the PC and the PC jumps to the memory location pointed to the SKIP. (Ensure that the memory location must be within the allowed range of + 127 to 128.)



### 6.6.11 BTJRT-Bit Test, Jump Relative on True

**BTJRT** dst, src.b

**Operation:** If src (b) is a "1", then  $PC \leftarrow PC + dst$

The specified bit within the source operand is tested. If it is a "1", the relative address is added to the program counter and control passes to the statement whose address is now in the PC; otherwise, the instruction following the BTJRT instruction is executed.

**Flags:** Does not affect any flags.

**Format:**

| (NOTE) |             |     | Bytes | Cycles | Opcode<br>(Hex) | Addr Mode<br>dst | src |
|--------|-------------|-----|-------|--------|-----------------|------------------|-----|
| opc    | src   b   1 | dst | 3     | 10     | 37              | RA               | rb  |

**NOTE:** In the second byte of the instruction format, the source address is 4 bits, the bit address "b" is 3 bits, and the LSB address value is 1 bit in length.

**Example:** Given: R1 = 07H:

```
BTJRT SKIP, R1.1
```

If working register R1 contains the value 07H (00000111B), the statement "BTJRT SKIP, R1.1" tests bit 1 in the source register (R1). As it is a "1", the relative address is added to the PC and the PC jumps to the memory location pointed to by the SKIP. (Ensure that the memory location must be within the allowed range of + 127 to 128.)

### 6.6.12 BXOR-Bit XOR

**BXOR** dst, src.b

**BXOR** dst.b, src

**Operation:** dst (0) ← dst (0) XOR src (b)

or

dst (b) ← dst (b) XOR src (0)

The specified bit of the source (or the destination) is logically exclusive-ORed with bit zero (LSB) of the destination (or source). The result bit is stored in the specified bit of the destination. It does not affect other bits of destination. It does not affect the source.

- Flags:**
- C:** Does not affect.
  - Z:** Set if the result is "0"; otherwise it clears.
  - S:** Clears to "0".
  - V:** Does not define.
  - D:** Does not affect.
  - H:** Does not affect.

#### Format:

|     |             |     | Bytes | Cycles | Opcode<br>(Hex) | Addr Mode<br>dst | src |
|-----|-------------|-----|-------|--------|-----------------|------------------|-----|
| opc | dst   b   0 | src | 3     | 6      | 27              | r0               | Rb  |
| opc | src   b   1 | dst | 3     | 6      | 27              | Rb               | r0  |

**NOTE:** In the second byte of the 3 byte instruction formats, the destination (or source) address is four bits, the bit address 'b' is three bits, and the LSB address value is one bit in length.

**Examples:** Given: R1 = 07H (00000111B) and register 01H = 03H (00000011B):

```
BXOR R1, 01H.1 → R = 06H, register 01H = 03H
BXOR 01H.2, R1 → Register 01H = 07H, R1 = 07H
```

In the first example, destination working register R1 has the value 07H (00000111B) and source register 01H has the value 03H (00000011B). The statement "BXOR R1, 01H.1" exclusive-ORs bit 1 of register 01H (source) with bit 0 of R1 (destination). The result bit value is stored in bit 0 of R1, changing its value from 07H to 06H. It does not affect the value of source register 01H.

### 6.6.13 CALL-Call Procedure

**CALL**           dst

**Operation:**    SP    ←    SP-1  
                   @SP ←    PCL  
                   SP    ←    SP-1  
                   @SP ←    PCH  
                   PC    ←    dst

The current contents of the program counter are pushed onto the top of the stack. The program counter value used is the address of the first instruction following the CALL instruction. The specified destination address is then loaded into the program counter and points to the first instruction of a procedure. At the end of the procedure the return instruction (RET) can be used to return to the original program flow. RET pops the top of the stack back into the program counter.

**Flags:**        Does not affect any flags.

**Format:**

|     |     | Bytes | Cycles | Opcode<br>(Hex) | Addr Mode<br>dst |
|-----|-----|-------|--------|-----------------|------------------|
| opc | dst | 3     | 14     | F6              | DA               |
| opc | dst | 2     | 12     | F4              | IRR              |
| opc | dst | 2     | 14     | D4              | IA               |

**Examples:**    Given: R0 = 35H, R1 = 21H, PC = 1A47H, and SP = 0002H:

```
CALL  3521H  →      SP = 0000H
                        (Memory locations 0000H = 1AH, 0001H = 4AH, where
                        4AH is the address that follows the instruction.)
CALL  @RR0   →      SP = 0000H (0000H = 1AH, 0001H = 49H)
CALL  #40H   →      SP = 0000H (0000H = 1AH, 0001H = 49H)
```

In the first example, when the program counter value is 1A47H and the stack pointer contains the value 0002H, the statement "CALL 3521H" pushes the current PC value onto the top of the stack. The stack pointer now points to memory location 0000H. The PC is then loaded with the value 3521H, the address of the first instruction in the program sequence to be executed.

If the contents of the program counter and stack pointer are similar in the first example, the statement "CALL @RR0" produces the same result except that the 49H is stored in stack location 0001H (because the two-byte instruction format was used). The PC is then loaded with the value 3521H, the address of the first instruction in the program sequence to be executed. Assuming that the contents of the program counter and stack pointer are the same as in the first example, when the program address 0040H contains 35H and program address 0041H contains 21H, the statement "CALL #40H" produces the same result as in the second example.

### 6.6.14 CCF-Complement Carry Flag

#### CCF

**Operation:**  $C \leftarrow \text{NOT } C$

Complements the carry flag (C). When C = "1", the value of the carry flag is changed to logic zero; if C = "0", the value of the carry flag is changed to logic one.

**Flags:** **C:** Complements.

Does not affect any other flags.

#### Format:

|     | Bytes | Cycles | Opcode<br>(Hex) |
|-----|-------|--------|-----------------|
| opc | 1     | 4      | EF              |

**Example:** Given: The carry flag = "0":

CCF

When the carry flag = "0", the CCF instruction complements it in the FLAGS register (0D5H), changing its value from logic zero to logic one.

### 6.6.15 CLR-Clear

**CLR** dst

**Operation:** dst ← "0"

Clears the destination location to "0".

**Flags:** Does not affect any other flags..

**Format:**

|     |     | Bytes | Cycles | Opcode<br>(Hex) | Addr Mode<br>dst |
|-----|-----|-------|--------|-----------------|------------------|
| opc | dst | 2     | 4      | B0              | R                |
|     |     |       | 4      | B1              | IR               |

**Examples:** Given: Register 00H = 4FH, register 01H = 02H, and register 02H = 5EH:

```
CLR 00H → Register 00H = 00H
CLR @01H → Register 01H = 02H, register 02H = 00H
```

In Register (R) addressing mode, the statement "CLR 00H" clears the destination register 00H value to 00H. In the second example, the statement "CLR @01H" uses Indirect Register (IR) addressing mode to clear the 02H register value to 00H.

### 6.6.16 COM-Complement

**COM**            dst

**Operation:**    dst ← NOT dst

Complements the contents of the destination location (one's complement); all "1s" are changed to "0s", and vice-versa.

- Flags:**
- C:**     Does not affect.
  - Z:**     Set if the result is "0"; cleared otherwise.
  - S:**     Set if the result bit 7 is set; cleared otherwise.
  - V:**     Always reset to "0".
  - D:**     Does not affect.
  - H:**     Does not affect.

**Format:**

|     |     | Bytes | Cycles | Opcode<br>(Hex) | Addr Mode<br>dst |
|-----|-----|-------|--------|-----------------|------------------|
| opc | dst | 2     | 4      | 60              | R                |
|     |     |       | 4      | 61              | IR               |

**Examples:**    Given: R1 = 07H and register 07H = 0F1H:

```
COM    R1        →     R1 = 0F8H
COM    @R1      →     R1 = 07H, register 07H = 0EH
```

In the first example, destination working register R1 contains the value 07H (00000111B). The statement "COM R1" complements all the bits in R1: it changes all logic ones to logic zeros, and vice-versa, leaving the value 0F8H (11111000B).

In the second example, it uses Indirect Register (IR) addressing mode to complement the value of destination register 07H (11110001B) by leaving the new value 0EH (00001110B).

### 6.6.17 CP-Compare

**CP** dst, src

**Operation:** dst-src

The source operand is compared to (subtract from) the destination operand, and it sets the appropriate flags accordingly. The contents of both operands are unaffected by the comparison.

- Flags:**
- C:** Sets if a "borrow" occurs (src > dst); otherwise it clears.
  - Z:** Sets if the result is "0"; otherwise it clears.
  - S:** Sets if the result is negative; otherwise it clears.
  - V:** Sets if arithmetic overflow occurred; otherwise it clears.
  - D:** Does not affect.
  - H:** Does not affect.

**Format:**

|     |           | Bytes | Cycles | Opcode<br>(Hex) | Addr Mode<br>dst | src |
|-----|-----------|-------|--------|-----------------|------------------|-----|
| opc | dst   src | 2     | 4      | A2              | r                | r   |
|     |           |       | 6      | A3              | r                | lr  |
| opc | src       | 3     | 6      | A4              | R                | R   |
|     |           |       | 6      | A5              | R                | IR  |
| opc | dst       | 3     | 6      | A6              | R                | IM  |

- Examples:**
- Given: R1 = 02H and R2 = 03H:  

```
CP    R1, R2 → Set the C and S flags
```

Destination working register R1 contains the value 02H and source register R2 contains the value 03H. The statement "CP R1, R2" subtracts the R2 value (source/subtrahend) from the R1 value (destination/minuend). As a "borrow" occurs and the difference is negative, C and S are "1".

- Given: R1 = 05H and R2 = 0AH:  

```
CP    R1, R2
JP    UGE, SKIP
INC   R1
SKIP  LD    R3, R1
```

In this example, destination working register R1 contains the value 05H which is less than the contents of the source working register R2 (0AH). The statement "CP R1, R2" generates C = "1". The JP instruction does not jump to the SKIP location. After the statement "LD R3, R1" executes, the value 06H remains in working register R3.

### 6.6.18 CPIJE-Compare, Increment, and Jump on Equal

**CPIJE** dst, src, RA

**Operation:** If dst-src = "0", PC ← PC + RA

Ir ← Ir + 1

The source operand is compared to (subtracts from) the destination operand. When the result is "0", the relative address is added to the program counter and the control passes to the statement whose address is now in the program counter. Otherwise, the instruction immediately following the CPIJE instruction is executed. In either case, the source pointer is incremented by one before the next instruction is executed.

**Flags:** Does not affect any flags.

**Format:**

|     |     |     |    | Bytes | Cycles | Opcode<br>(Hex) | Addr Mode<br>dst | src |
|-----|-----|-----|----|-------|--------|-----------------|------------------|-----|
| opc | src | dst | RA | 3     | 12     | C2              | r                | Ir  |

**NOTE:** Execution time is 18 cycles if the jump is taken or 16 cycles if it is not taken.

**Example:** Given: R1 = 02H, R2 = 03H, and register 03H = 02H:

```
CPIJE R1, @R2, SKIP → R2 = 04H, PC jumps to SKIP location
```

In this example, working register R1 contains the value 02H, working register R2 contains the value 03H, and register 03 contains 02H. The statement "CPIJE R1, @R2, SKIP" compares the @R2 value 02H (00000010B) to 02H (00000010B). As the result of the comparison is equal, the relative address is added to the PC and the PC then jumps to the memory location that SKIP points to. The source register (R2) is incremented by one, leaving a value of 04H. (Ensure that the memory location is within the allowed range of + 127 to – 128.)



### 6.6.19 CPIJNE-Compare, Increment, and Jump on Non-Equal

**CPIJNE** dst, src, RA

**Operation:** If dst-src "0", PC ← PC + RA

Ir ← Ir + 1

The source operand is compared to (subtracts from) the destination operand. When the result is not "0", the relative address is added to the program counter and control passes to the statement whose address is now in the program counter; otherwise the instruction following the CPIJNE instruction is executed. In either case the source pointer is incremented by one before the next instruction.

**Flags:** Does not affect any flags.

**Format:**

|     |     |     |    | Bytes | Cycles | Opcode<br>(Hex) | Addr Mode<br>dst | src |
|-----|-----|-----|----|-------|--------|-----------------|------------------|-----|
| opc | src | dst | RA | 3     | 12     | D2              | r                | Ir  |

**NOTE:** Execution time is 18 cycles if the jump is taken or 16 cycles if it is not taken.

**Example:** Given: R1 = 02H, R2 = 03H, and register 03H = 04H:

CPIJNE R1, @R2, SKIP → R2 = 04H, PC jumps to SKIP location

Working register R1 contains the value 02H, working register R2 (the source pointer) the value 03H, and general register 03 contains the value 04H. The statement "CPIJNE R1, @R2, SKIP" subtracts 04H (00000100B) from 02H (00000010B). As the result of the comparison is non-equal, the relative address is added to the PC and the PC then jumps to the memory location that SKIP points to. The source pointer register (R2) is also incremented by one, leaving a value of 04H. (Ensure that the memory location is within the allowed range of + 127 to – 128.)

### 6.6.20 DA-Decimal Adjust

**DA**            dst

**Operation:**    dst ← DA dst

The destination operand is adjusted to form two 4-bit BCD digits after an addition or subtraction operation. For addition (ADD, ADC) or subtraction (SUB, SBC), the following table indicates the operation that it performs (The operation is undefined if the destination operand was not the result of a valid addition or subtraction of BCD digits):

| Instruction | Carry Before DA | Bits 4–7 Value (Hex) | H Flag Before DA | Bits 0–3 Value (Hex) | Number Added to Byte | Carry After DA |
|-------------|-----------------|----------------------|------------------|----------------------|----------------------|----------------|
| –           | 0               | 0–9                  | 0                | 0–9                  | 00                   | 0              |
| –           | 0               | 0–8                  | 0                | A–F                  | 06                   | 0              |
| –           | 0               | 0–9                  | 1                | 0–3                  | 06                   | 0              |
| ADD         | 0               | A–F                  | 0                | 0–9                  | 60                   | 1              |
| ADC         | 0               | 9–F                  | 0                | A–F                  | 66                   | 1              |
| –           | 0               | A–F                  | 1                | 0–3                  | 66                   | 1              |
| –           | 1               | 0–2                  | 0                | 0–9                  | 60                   | 1              |
| –           | 1               | 0–2                  | 0                | A–F                  | 66                   | 1              |
| –           | 1               | 0–3                  | 1                | 0–3                  | 66                   | 1              |
| –           | 0               | 0–9                  | 0                | 0–9                  | 00 = – 00            | 0              |
| SUB         | 0               | 0–8                  | 1                | 6–F                  | FA = – 06            | 0              |
| SBC         | 1               | 7–F                  | 0                | 0–9                  | A0 = – 60            | 1              |
| –           | 1               | 6–F                  | 1                | 6–F                  | 9A = – 66            | 1              |

**Flags:**        **C:**    Sets if there was a carry from the most significant bit; otherwise it clears (see table).

**Z:**            Sets if result is "0"; otherwise it clears.

**S:**            Sets if result bit 7 is set; otherwise it clears.

**V:**            Does not define.

**D:**            Does not affect.

**H:**            Does not affect.

**Format:**

|            |  | Bytes | Cycles | Opcode (Hex) | Addr Mode |
|------------|--|-------|--------|--------------|-----------|
| opc    dst |  | 2     | 4      | 40           | R         |
|            |  |       | 4      | 41           | IR        |

### 6.6.21 DA-Decimal Adjust

**DA** (Continued)

**Example:** Given: Working register R0 contains the value 15 (BCD), working register R1 contains 27 (BCD), and address 27H contains 46 (BCD):

```
ADD    R1, R0 ; C ← "0", H ← "0", Bits 4-7 = 3, bits 0-3 = C, R1 ← 3CH
DA     R1     ; R1 ← 3CH + 06
```

If addition is performed by using the BCD values 15 and 27, the result should be 42. However, the sum is incorrect, however, when the binary representations are added in the destination location by using standard binary arithmetic:

```
  0 0 0 1 0 1 0 1  15
+ 0 0 1 0 0 1 1 1  27
  0 0 1 1 1 1 0 0  =   3CH
```

The DA instruction adjusts this result so that the correct BCD representation is obtained:

```
  0 0 1 1 1 1 0 0
+ 0 0 0 0 0 1 1 0
  0 1 0 0 0 0 1 0  =   42
```

Assuming the same values provided previously, the statements

```
SUB    27H, R0 ; C ← "0", H ← "0", Bits 4-7 = 3, bits 0-3 = 1
DA     @R1     ; @R1 ← 31-0
```

Leave the value 31 (BCD) in address 27H (@R1).

### 6.6.22 DEC-Decrement

**DEC**            dst

**Operation:**    dst ← dst-1

The contents of the destination operand are decremented by one.

- Flags:**
- C:**    Does not affect.
  - Z:**    Sets if the result is "0"; otherwise it clears.
  - S:**    Sets if result is negative; otherwise it clears.
  - V:**    Sets if arithmetic overflow occurred; otherwise it clears.
  - D:**    Does not affect.
  - H:**    Does not affect.

**Format:**

|     |     | Bytes | Cycles | Opcode<br>(Hex) | Addr Mode<br>dst |
|-----|-----|-------|--------|-----------------|------------------|
| opc | dst | 2     | 4      | 00              | R                |
|     |     |       | 4      | 01              | IR               |

**Examples:**    Given: R1 = 03H and register 03H = 10H:

```
DEC   R1      →   R1 = 02H
DEC   @R1     →   Register 03H = 0FH
```

In the first example, if working register R1 contains the value 03H, the statement "DEC R1" decrements the hexadecimal value by 1, leaving the value 02H. In the second example, the statement "DEC @R1" decrements the value 10H contained in the destination register 03H by 1, leaving the value 0FH.

### 6.6.23 DECW-Decrement Word

**DECW**          dst

**Operation:**    dst ← dst-1

The contents of the destination location (which must be an even address) and the operand following that location are treated as a single 16-bit value that is decremented by one.

- Flags:**
- C:**     Does not affect.
  - Z:**     Sets if the result is "0"; otherwise it clears.
  - S:**     Sets if the result is negative; otherwise it clears.
  - V:**     Sets if arithmetic overflow occurred; otherwise it clears.
  - D:**     Does not affect.
  - H:**     Does not affect.

**Format:**

|     |     | Bytes | Cycles | Opcode<br>(Hex) | Addr Mode<br>dst |
|-----|-----|-------|--------|-----------------|------------------|
| opc | dst | 2     | 8      | 80              | RR               |
|     |     |       | 8      | 81              | IR               |

**Examples:**     Given: R0 = 12H, R1 = 34H, R2 = 30H, register 30H = 0FH, and register 31H = 21H:

```
DECW  RR0    →    R0 = 12H, R1 = 33H
DECW  @R2    →    Register 30H = 0FH, register 31H = 20H
```

In the first example, destination register R0 contains the value 12H and register R1 contains the value 34H. The statement "DECW RR0" addresses R0 and the next operand R1 as a 16-bit word and decrements the value of R1 by1, leaving the value 33H.

**NOTE:** A system malfunction may occur if you use a Zero flag (FLAGS.6) result together with a DECW instruction. To avoid this problem, that you should use DECW as shown in this example:

```
LOOP:  DECW   RR0
        LD     R2, R1
        OR     R2, R0
        JR     NZ, LOOP
```

### 6.6.24 DI-Disable Interrupts

#### DI

**Operation:** SYM (0) ← 0

Bit zero of the system mode control register, SYM.0, is cleared to "0" by globally disabling all interrupt processing. Interrupt requests continues to set their respective interrupt pending bits, however the CPU does not service them when it disables the interrupt processing.

**Flags:** Does not affect any flags.

#### Format:

|     | Bytes | Cycles | Opcode<br>(Hex) |
|-----|-------|--------|-----------------|
| opc | 1     | 4      | 8F              |

**Example:** Given: SYM = 01H:

DI

When the value of the SYM register is 01H, the statement "DI" leaves the new value 00H in the register and clears SYM.0 to "0" by disabling the interrupt processing.

Before changing IMR, interrupt pending and interrupt source control register, ensure that it is in the DI state.

### 6.6.25 DIV-Divide (Unsigned)

**DIV** dst, src

**Operation:** dst ÷ src

dst (UPPER) ← REMAINDER

dst (LOWER) ← QUOTIENT

The source operand (8 bits) divides the destination operand (16 bits). The quotient (8 bits) is stored in the lower half of the destination. The remainder (8 bits) is stored in the upper half of the destination. When the quotient is  $\geq 2^8$ , the numbers that it stores in the upper and lower halves of the destination for quotient and remainder are incorrect. Both operands are treated as unsigned integers.

**Flags:** **C:** Sets if the V flag is set and quotient is between  $2^8$  and  $2^9 - 1$ ; otherwise it clears.

**Z:** Set if divisor or quotient = "0"; otherwise it clears.

**S:** Sets if MSB of quotient = "1"; otherwise it clears.

**V:** Sets if quotient is  $\geq 2^8$  or if divisor = "0"; otherwise it clears.

**D:** Does not affect.

**H:** Does not affect.

**Format:**

|     |     |     | Bytes | Cycles | Opcode<br>(Hex) | Addr Mode<br>dst | src |
|-----|-----|-----|-------|--------|-----------------|------------------|-----|
| opc | src | dst | 3     | 26/10  | 94              | RR               | R   |
|     |     |     |       | 26/10  | 95              | RR               | IR  |
|     |     |     |       | 26/10  | 96              | RR               | IM  |

**NOTE:** Execution takes 10 cycles if the divide-by-zero is attempted; otherwise it takes 26 cycles.

**Examples:** Given: R0 = 10H, R1 = 03H, R2 = 40H, register 40H = 80H:

```
DIV RR0, R2      → R0 = 03H, R1 = 40H
DIV RR0, @R2     → R0 = 03H, R1 = 20H
DIV RR0, #20H    → R0 = 03H, R1 = 80H
```

In the first example, destination working register pair RR0 contains the values 10H (R0) and 03H (R1), and register R2 contains the value 40H. The statement "DIV RR0, R2" divides the 16-bit RR0 value by the 8-bit value of the R2 (source) register. After the DIV instruction, R0 contains the value 03H and R1 contains 40H. The 8-bit remainder is stored in the upper-half of the destination register RR0 (R0) and the quotient in the lower-half (R1).

### 6.6.26 DJNZ-Decrement and Jump if Non-Zero

**DJNZ**            r, dst

**Operation:**     $r \leftarrow r-1$

If  $r \neq 0$ ,  $PC \leftarrow PC + dst$

The working register being used as a counter is decremented. If the contents of the register are not logic zero after decrementing, the relative address is added to the program counter and control passes to the statement whose address is now in the PC. The range of the relative address is + 127 to – 128 and the original value of the PC is taken to be the address of the instruction byte after the DJNZ statement.

**NOTE:** In case of using DJNZ instruction, the working register that it uses as a counter should be set at one of locations 0C0H to 0CFH with SRP, SRP0, or SRP1 instruction.

**Flags:**            Does not affect any flags.

**Format:**

|         |     | Bytes | Cycles                        | Opcode<br>(Hex)  | Addr Mode<br>dst |
|---------|-----|-------|-------------------------------|------------------|------------------|
| r   opc | dst | 2     | 8 (Jump taken)<br>8 (No jump) | rA<br>r = 0 to F | RA               |

**Example:**        Given: R1 = 02H and LOOP is the label of a relative address:

```
SRP     #0C0H
DJNZ    R1, LOOP
```

DJNZ is typically used to control a "loop" of instructions. In many cases, a label is used as the destination operand instead of a numeric relative address value. In the example, working register R1 contains the value 02H, and LOOP is the label for a relative address.

The statement "DJNZ R1, LOOP" decrements register R1 by one by leaving the value 01H. As the contents of R1 after the decrement are non-zero, the jump is taken to the relative address that the LOOP label specifies.



### 6.6.27 EI-Enable Interrupts

#### EI

**Operation:** SYM (0) ← 1

An EI instruction sets bit 0 of the system mode register, SYM.0 to "1". This enables interrupts to be serviced as they occur (assuming they have highest priority). If the pending bit of an interrupt is set while interrupt processing was disabled (by executing a DI instruction), it will be serviced when you execute the EI instruction.

**Flags:** Does not affect any flags.

#### Format:

|     | Bytes | Cycles | Opcode<br>(Hex) |
|-----|-------|--------|-----------------|
| opc | 1     | 4      | 9F              |

**Example:** Given: SYM = 00H:

EI

If the SYM register contains the value 00H, that is, if interrupts are currently disabled, the statement "EI" sets the SYM register to 01H by enabling all interrupts. (SYM.0 is the enable bit for global interrupt processing.)

### 6.6.28 ENTER-Enter

#### ENTER

**Operation:**

|     |   |        |
|-----|---|--------|
| SP  | ← | SP-2   |
| @SP | ← | IP     |
| IP  | ← | PC     |
| PC  | ← | @IP    |
| IP  | ← | IP + 2 |

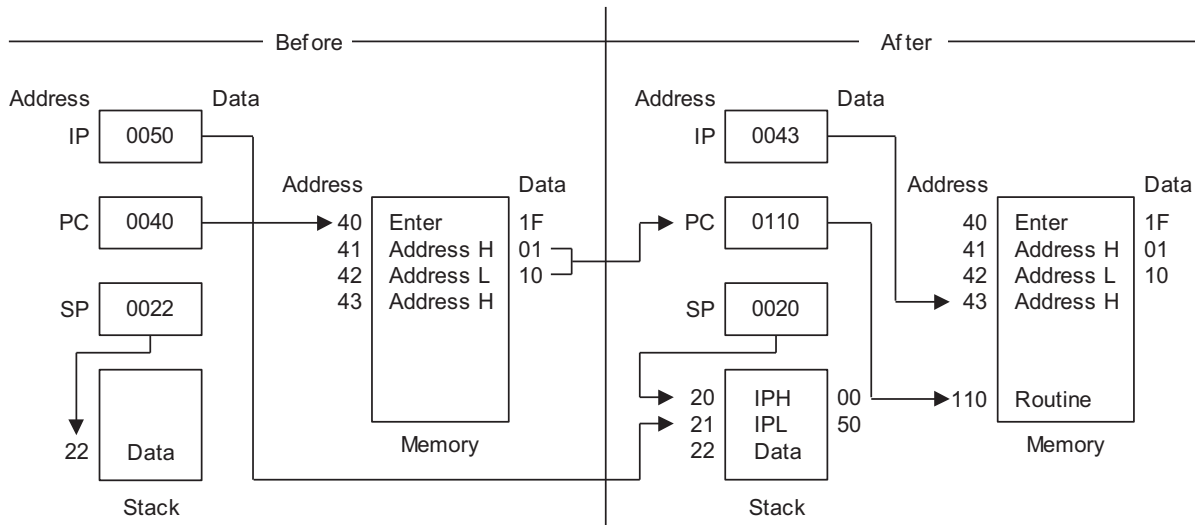
This instruction is useful when implementing threaded-code languages. The contents of the instruction pointer are pushed to the stack. The program counter (PC) value is then written to the instruction pointer. The program memory word that is pointed to by the instruction pointer is loaded into the PC, and the instruction pointer is incremented by two.

**Flags:** Does not affect any flags.

**Format:**

|     | Bytes | Cycles | Opcode<br>(Hex) |
|-----|-------|--------|-----------------|
| opc | 1     | 14     | 1F              |

**Example:** The diagram below shows one example of how to use an ENTER statement.



6.6.29 EXIT-Exit

EXIT

**Operation:**

|    |   |        |
|----|---|--------|
| IP | ← | @SP    |
| SP | ← | SP + 2 |
| PC | ← | @IP    |
| IP | ← | IP + 2 |

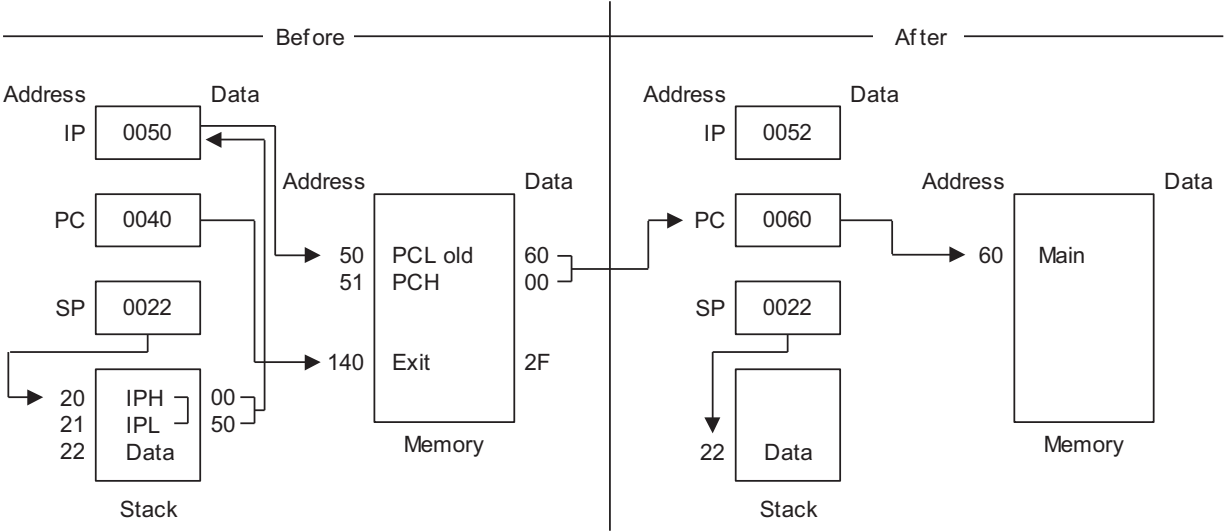
This instruction is useful when implementing threaded-code languages. The stack value is popped and loaded into the instruction pointer. The program memory word that is pointed to by the instruction pointer is then loaded into the program counter, and the instruction pointer is incremented by two.

**Flags:** Does not affect any flags.

**Format:**

| opc | Bytes | Cycles              | Opcode (Hex) |
|-----|-------|---------------------|--------------|
|     | 1     | 14 (Internal stack) | 2F           |
|     |       | 16 (Internal stack) |              |

**Example:** The diagram below shows one example of how to use an EXIT statement.





6.6.30 IDLE-Idle Operation

IDLE

Operation:

The IDLE instruction stops the CPU clock while allowing system clock oscillation to continue. An Interrupt request (IRQ) or external reset operation release idle.

Flags: Does not affect any flags.

Format:

|  | Bytes | Cycles | Opcode (Hex) | Addr Mode dst | src |
|--|-------|--------|--------------|---------------|-----|
| <div style="border: 1px solid black; padding: 2px; display: inline-block;">opc</div> | 1     | 4      | 6F           |               |     |

Example: The instruction

IDLE

Stops the CPU clock but not the system clock.

### 6.6.31 INC-Increment

**INC**            dst

**Operation:**    dst ← dst + 1

The contents of the destination operand are incremented by one.

- Flags:**
- C:**    Does not affect.
  - Z:**    Set if the result is "0"; otherwise it clears.
  - S:**    Set if the result is negative; otherwise it clears.
  - V:**    Set if arithmetic overflow occurred; otherwise it clears.
  - D:**    Does not affect.
  - H:**    Does not affect.

**Format:**

|              |  | Bytes | Cycles | Opcode (Hex) | Addr Mode |
|--------------|--|-------|--------|--------------|-----------|
| dst   opc    |  | 1     | 4      | rE           | r         |
|              |  |       |        | r = 0 to F   |           |
| opc      dst |  | 2     | 4      | 20           | R         |
|              |  |       | 4      | 21           | IR        |

**Examples:**    Given: R0 = 1BH, register 00H = 0CH, and register 1BH = 0FH:

```
INC  R0    →    R0 = 1CH
INC  00H   →    Register 00H = 0DH
INC  @R0   →    R0 = 1BH, register 01H = 10H
```

In the first example, if destination working register R0 contains the value 1BH, the statement "INC R0" leaves the value 1CH in that same register.

The next example shows the effect an INC instruction has on register 00H, assuming that it contains the value 0CH.

In the third example, INC is used in Indirect Register (IR) addressing mode to increment the value of register 1BH from 0FH to 10H.

### 6.6.32 INCW-Increment Word

**INCW**            dst

**Operation:**    dst ← dst + 1

It treats the contents of the destination (which must be an even address) and the byte following that location as a single 16-bit value. This value is incremented by one.

- Flags:**
- C:**     Does not affect.
  - Z:**     Set if the result is "0"; otherwise it clears.
  - S:**     Set if the result is negative; otherwise it clears.
  - V:**     Set if arithmetic overflow occurred; otherwise it clears.
  - D:**     Does not affect.
  - H:**     Does not affect.

**Format:**

|     |     | Bytes | Cycles | Opcode<br>(Hex) | Addr Mode<br>dst |
|-----|-----|-------|--------|-----------------|------------------|
| opc | dst | 2     | 8      | A0              | RR               |
|     |     |       | 8      | A1              | IR               |

**Examples:**     Given: R0 = 1AH, R1 = 02H, register 02H = 0FH, and register 03H = 0FFH:

```
INCW  RR0  →   R0 = 1AH, R1 = 03H
INCW  @R1  →   Register 02H = 10H, register 03H = 00H
```

In the first example, the working register pair RR0 contains the value 1AH in register R0 and 02H in register R1. The statement "INCW RR0" increments the 16-bit destination by one, leaving the value 03H in register R1. In the second example, the statement "INCW @R1" uses Indirect Register (IR) addressing mode to increment the contents of general register 03H from 0FFH to 00H and register 02H from 0FH to 10H.

**NOTE:** A system malfunction may occur if you use a Zero (Z) flag (FLAGS.6) result together with an INCW instruction. To avoid this problem, you should use INCW as shown :

```
LOOP:  INCW  RR0
        LD   R2, R1
        OR   R2, R0
        JR   NZ, LOOP
```

### 6.6.33 IRET-Interrupt Return

**IRET**            IRET (Normal)            IRET (Fast)

**Operation:**     $FLAGS \leftarrow @SPPC \leftrightarrow IP$   
 $SP \leftarrow SP + 1$              $FLAGS \leftarrow FLAGS$   
 $PC \leftarrow @SP$              $FIS \leftarrow 0$   
 $SP \leftarrow SP + 2$   
 $SYM(0) \leftarrow 1$

This instruction is used at the end of an interrupt service routine. It restores the flag register and the program counter. It also re-enables global interrupts. A "normal IRET" is executed only if the fast interrupt status bit (FIS, bit one of the FLAGS register, 0D5H) is cleared (= "0"). If a fast interrupt occurred, IRET clears the FIS bit that was set at the beginning of the service routine.

**Flags:**            Restores all flags to their original settings (that is, the settings before the interrupt occurs).

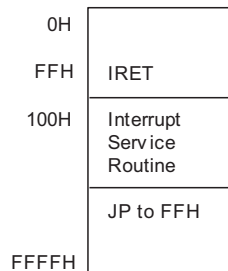
**Format:**

| IRET (Normal) | Bytes | Cycles                                     | Opcode (Hex) |
|---------------|-------|--|--------------|
| opc           | 1     | 10 (Internal stack)<br>12 (Internal stack) | BF           |

| IRET (Fast) | Bytes | Cycles | Opcode (Hex) |
|-------------|-------|--------|--------------|
| opc         | 1     | 6      | BF           |

**Example:** In the figure below, the instruction pointer is initially loaded with 100H in the main program before interrupts are enabled. When an interrupt occurs, the program counter and instruction pointer are swapped. This causes the PC to jump to address 100H and the IP to keep the return address. The last instruction in the service routine normally is a jump to IRET at address FFH. This causes the instruction pointer to be loaded with 100H "again" and the program counter to jump back to the main program. Now, the next interrupt can occur and the IP is still correct at 100H.



**NOTE:** In this fast interrupt example in the figure above, if the last instruction is not a jump to IRET, you must pay attention to the order of the last two instructions. The IRET cannot be immediately preceded by a clearing of the interrupt status (as with a reset of the IPR register).

### 6.6.34 JP-Jump

**JP** cc, dst (Conditional)

**JP** dst (Unconditional)

**Operation:** If cc is true, PC ← dst

The conditional JUMP instruction transfers program control to the destination address when the condition that condition code (cc) specifies is true; otherwise, the instruction following the JP instruction is executed. The unconditional JP simply replaces the contents of the PC with the contents of the specified register pair. Control then passes to the statement addressed by the PC.

**Flags:** Does not affect any flags.

**Format:** (1)

|          |     | Bytes | Cycles | Opcode<br>(Hex) | Addr Mode<br>dst |
|----------|-----|-------|--------|-----------------|------------------|
| (2)      |     |       |        |                 |                  |
| cc   opc | dst | 3     | 8      | ccD             | DA               |
|          |     |       |        | cc = 0 to F     |                  |
| opc      | dst | 2     | 8      | 30              | IRR              |

**NOTE:**

1. You can use the 3 byte format for a conditional jump and the 2 byte format for an unconditional jump.
2. In the first byte of the three-byte instruction format (conditional jump), the condition code and the opcode are both four bits.

**Examples:** Given: The carry flag (C) = "1", register 00 = 01H, and register 01 = 20H:

```
JP    C, LABEL_W    →    LABEL_W = 1000H, PC = 1000H
JP    @00H          →    PC = 0120H
```

The first example shows a conditional JP. Assuming that you can set the carry flag to "1", the statement

"JP C, LABEL\_W" replaces the contents of the PC with the value 1000H and transfers control to that location. Had the carry flag not been set, control would then have passed to the statement immediately to the next JP instruction.

The second example shows an unconditional JP. The statement "JP@00" replaces the contents of the PC with the contents of the register pair 00H and 01H by leaving the value 0120H.



### 6.6.35 JR-Jump Relative

**JR** cc, dst

**Operation:** If cc is true,  $PC \leftarrow PC + dst$

When the condition specified by the condition code (cc) is true, the relative address is added to the program counter and control passes to the statement whose address is now in the program counter; otherwise, the instruction following the JR instruction is executed. (Refer to the list of condition codes for more information).

The range of the relative address is + 127, – 128, and the original value of the program counter is taken to be the address of the first instruction byte following the JR statement.

**Flags:** Does not affect any flags.

**Format:**

| (NOTE)      |     | Bytes | Cycles | Opcode<br>(Hex) | Addr Mode<br>dst |
|-------------|-----|-------|--------|-----------------|------------------|
| cc   opc    | dst | 2     | 6      | ccB             | RA               |
| cc = 0 to F |     |       |        |                 |                  |

**NOTE:** In the first byte of the 2 byte instruction format, the condition code and the opcode are each four bits.

**Example:** Given: The carry flag = "1" and LABEL\_X = 1FF7H:

JR C, LABEL\_X → PC = 1FF7H

If you set the carry flag (that is, if the condition code is true), the statement "JR C, LABEL\_X" passes control to the statement whose address is currently in the PC. Otherwise, the program instruction following the JR would be executed.

### 6.6.36 LD-Load

**LD** dst, src

**Operation:** dst ← src

The contents of the source are loaded into the destination. The source's contents are unaffected.

**Flags:** Does not affect any flags.

**Format:**

|           |           | Bytes | Cycles | Opcode<br>(Hex) | Addr Mode<br>dst | src  |            |
|-----------|-----------|-------|--------|-----------------|------------------|------|------------|
| dst   opc | src       | 2     | 4      | rC              | r                | IM   |            |
|           |           |       | 4      | r8              | r                | R    |            |
| src   opc | dst       | 2     | 4      | r9              | R                | r    |            |
|           |           |       |        |                 |                  |      | r = 0 to F |
| opc       | dst   src | 2     | 4      | C7              | r                | lr   |            |
|           |           |       | 4      | D7              | lr               | r    |            |
| opc       | src       | 3     | 6      | E4              | R                | R    |            |
|           |           |       | 6      | E5              | R                | IR   |            |
| opc       | dst       | 3     | 6      | E6              | R                | IM   |            |
|           |           |       | 6      | D6              | IR               | IM   |            |
| opc       | src       | dst   | 3      | 6               | F5               | IR   | R          |
| opc       | dst   src | x     | 3      | 6               | 87               | r    | x[r]       |
| opc       | src   dst | x     | 3      | 6               | 97               | x[r] | r          |

### 6.6.37 LD-Load

**LD** (Continued)

**Examples:** Given: R0 = 01H, R1 = 0AH, register 00H = 01H, register 01H = 20H, register 02H = 02H, LOOP = 30H and register 3AH = 0FFH:

|    |               |   |   |
|----|---------------|---|---|
| LD | R0, #10H      | → | R0 = 10H  |
| LD | R0, 01H       | → | R0 = 20H, register 01H = 20H                              |
| LD | 01H, R0       | → | Register 01H = 01H, R0 = 01H                              |
| LD | R1, @R0       | → | R1 = 20H, R0 = 01H  |
| LD | @R0, R1       | → | R0 = 01H, R1 = 0AH, register 01H = 0AH                    |
| LD | 00H, 01H      | → | Register 00H = 20H, register 01 = 20H                     |
| LD | 02H,@00H      | → | Register 02H = 20H, register 00H = 01H                    |
| LD | 00H, #0AH     | → | Register 00H = 0AH  |
| LD | @00H, #10H    | → | Register 00H = 01H, register 01H = 10H                    |
| LD | @0H, 02H      | → | Register 00H = 01H, register 01H = 02, register 02H = 02H |
| LD | R0, #LOOP[R1] | → | R0 = 0FFH, R1 = 0AH                                       |
| LD | #LOOP[R0],R1  | → | Register 31H = 0AH, R0 = 01H, R1 = 0AH                    |

### 6.6.38 LDB-Load Bit

**LDB** dst, src.b

**LDB** dst.b, src

**Operation:** dst (0) ← src (b)

or

dst (b) ← src (0)

The specified bit of the source is loaded into bit zero (LSB) of the destination, or bit 0 of the source is loaded into the specified bit of the destination. No other bits of the destination are affected. The source is unaffected.

**Flags:** Does not affect any flags.

**Format:**

|     |             |     | Bytes | Cycles | Opcode<br>(Hex) | Addr Mode<br>dst | src |
|-----|-------------|-----|-------|--------|-----------------|------------------|-----|
| opc | dst   b   0 | src | 3     | 6      | 47              | r0               | Rb  |
| opc | src   b   1 | dst | 3     | 6      | 47              | Rb               | r0  |

**NOTE:** In the second byte of the instruction formats, the destination (or source) address is 4 bits, the bit address 'b' is 3 bits, and the LSB address value is 1-bit in length.

**Examples:** Given: R0 = 06H and general register 00H = 05H:

```
LDB R0, 00H.2 → R0 = 07H, register 00H = 05H
LDB 00H.0, R0 → R0 = 06H, register 00H = 04H
```

In the first example, destination working register R0 contains the value 06H and the source general register 00H the value 05H. The statement "LD R0,00H.2" loads the bit two value of the 00H register into bit zero of the R0 register by leaving the value 07H in register R0.

In the second example, 00H is the destination register. The statement "LD 00H.0,R0" loads bit zero of register R0 to the specified bit (bit zero) of the destination register by leaving 04H in general register 00H.

### 6.6.39 LDC/LDE-Load Memory

**LDC/LDE** dst, src

**Operation:** dst ← src

This instruction loads a byte from program or data memory into a working register or vice-versa. The source values are unaffected. LDC refers to program memory and LDE to data memory. The assembler makes "lrr" or "rr" values an even number for program memory and odd an od number for data memory.

**Flags:** Does not affect any flags.

**Format:**

|     |  | Bytes           | Cycles          | Opcode<br>(Hex) | Addr Mode<br>dst | src |     |            |            |         |
|-----|--|-----------------|-----------------|-----------------|------------------|-----|-----|------------|------------|---------|
| 1.  | <table border="1"><tr><td>opc</td><td>dst   src</td></tr></table>  | opc             | dst   src       | 2               | 10               | C3  | r   | lrr        |            |         |
| opc | dst   src  |                 |                 |                 |                  |     |     |            |            |         |
| 2.  | <table border="1"><tr><td>opc</td><td>src   dst</td></tr></table>  | opc             | src   dst       | 2               | 10               | D3  | lrr | r          |            |         |
| opc | src   dst  |                 |                 |                 |                  |     |     |            |            |         |
| 3.  | <table border="1"><tr><td>opc</td><td>dst   src</td><td>XS</td></tr></table>                                     | opc             | dst   src       | XS              | 3                | 12  | E7  | r          | XS<br>[rr] |         |
| opc | dst   src  | XS              |                 |                 |                  |     |     |            |            |         |
| 4.  | <table border="1"><tr><td>opc</td><td>src   dst</td><td>XS</td></tr></table>                                     | opc             | src   dst       | XS              | 3                | 12  | F7  | XS<br>[rr] | r          |         |
| opc | src   dst  | XS              |                 |                 |                  |     |     |            |            |         |
| 5.  | <table border="1"><tr><td>opc</td><td>dst   src</td><td>XL<sub>L</sub></td><td>XL<sub>H</sub></td></tr></table>  | opc             | dst   src       | XL <sub>L</sub> | XL <sub>H</sub>  | 4   | 14  | A7         | r          | XL [rr] |
| opc | dst   src  | XL <sub>L</sub> | XL <sub>H</sub> |                 |                  |     |     |            |            |         |
| 6.  | <table border="1"><tr><td>opc</td><td>src   dst</td><td>XL<sub>L</sub></td><td>XL<sub>H</sub></td></tr></table>  | opc             | src   dst       | XL <sub>L</sub> | XL <sub>H</sub>  | 4   | 14  | B7         | XL [rr]    | r       |
| opc | src   dst  | XL <sub>L</sub> | XL <sub>H</sub> |                 |                  |     |     |            |            |         |
| 7.  | <table border="1"><tr><td>opc</td><td>dst   0000</td><td>DA<sub>L</sub></td><td>DA<sub>H</sub></td></tr></table> | opc             | dst   0000      | DA <sub>L</sub> | DA <sub>H</sub>  | 4   | 14  | A7         | r          | DA      |
| opc | dst   0000   | DA <sub>L</sub> | DA <sub>H</sub> |                 |                  |     |     |            |            |         |
| 8.  | <table border="1"><tr><td>opc</td><td>src   0000</td><td>DA<sub>L</sub></td><td>DA<sub>H</sub></td></tr></table> | opc             | src   0000      | DA <sub>L</sub> | DA <sub>H</sub>  | 4   | 14  | B7         | DA         | r       |
| opc | src   0000   | DA <sub>L</sub> | DA <sub>H</sub> |                 |                  |     |     |            |            |         |
| 9.  | <table border="1"><tr><td>opc</td><td>dst   0001</td><td>DA<sub>L</sub></td><td>DA<sub>H</sub></td></tr></table> | opc             | dst   0001      | DA <sub>L</sub> | DA <sub>H</sub>  | 4   | 14  | A7         | r          | DA      |
| opc | dst   0001   | DA <sub>L</sub> | DA <sub>H</sub> |                 |                  |     |     |            |            |         |
| 10. | <table border="1"><tr><td>opc</td><td>src   0001</td><td>DA<sub>L</sub></td><td>DA<sub>H</sub></td></tr></table> | opc             | src   0001      | DA <sub>L</sub> | DA <sub>H</sub>  | 4   | 14  | B7         | DA         | r       |
| opc | src   0001   | DA <sub>L</sub> | DA <sub>H</sub> |                 |                  |     |     |            |            |         |

**NOTE:**

1. The source (src) or working register pair [rr] for formats 5 and 6 cannot use register pair 0-1.
2. For formats 3 and 4, the destination address "XS[rr]" and the source address "XS[rr]" are 1 byte each.
3. For formats 5 and 6, the destination address "XL[rr]" and the source address "XL[rr]" are 2 byte each.
4. The DA and r source values for formats 7 and 8 are used to address program memory. You can use the second set of values, used in formats 9 and 10, to address data memory.

### 6.6.40 LDC/LDE-Load Memory

**LDC/LDE** (Continued)

**Examples:** Given: R0 = 11H, R = 34H, R2 = 01H, R3 = 04H; Program memory locations 0103H = 4FH, 0104H = 1A, 0105H = 6DH, and 1104H = 88H. External data memory locations 0103H = 5FH, 0104H = 2AH, 0105H = 7DH, and 1104H = 98H:

```

LDC    R0,@RR2      ; R0 ← contents of program memory location 0104H
                    ; R0 = 1AH, R2 = 01H, R3 = 04H
LDE    R0,@RR2      ; R0 ← contents of external data memory location 0104H
                    ; R0 = 2AH, R2 = 01H, R3 = 04H
LDC (NOTE) @RR2, R0 ; 11H (contents of R0) is loaded into program memory
                    ; Location 0104H (RR2,)
                    ; Working registers R0, R2, R3 → no change
LDE    @RR2, R      ; 11H (contents of R0) is loaded into external data memory
                    ; Location 0104H (RR2),
                    ; Working registers R0, R2, R3 → no change
LDC    R0, #01H[RR2] ; R0 ← contents of program memory location 0105H
                    ; (01H + RR2),
                    ; R0 = 6DH, R2 = 01H, R3 = 04H
LDE    R0, #01H[RR2] ; R0 ← contents of external data memory location 0105H
                    ; (01H + RR2), R0 = 7DH, R2 = 01H, R3 = 04H
LDC (NOTE) #01H[RR2],R0; 11H (contents of R0) is loaded into program memory location
                    ; 0105H (01H + 0104H)
LDE#01H[RR2],R0    ; 11H (contents of R0) is loaded into external data memory
                    ; Location 0105H (01H + 0104H)
LDC    R0, #1000H[RR2]; R0 ← contents of program memory location 1104H
                    ; (1000H + 0104H), R0 = 88H, R2 = 01H, R3 = 04H
LDE    R0, #1000H[RR2]; R0 contents of external data memory location 1104H
                    ; (1000H + 0104H), R0 = 98H, R2 = 01H, R3 = 04H
LDC    R0, 1104H     ; R0 contents of program memory location 1104H, R0 = 88H
LDE    R0, 1104H     ; 0 ← contents of external data memory location 1104H,
                    ; R0 = 98H
LDC (NOTE) 1105H, R0 ; 11H (contents of R0) is loaded into program memory location
                    ; 1105H, (1105H) ← 11H
LDE    1105H, R0    ; 11H (contents of R0) is loaded into external data memory
                    ; Location 1105H, (1105H) ← 11H

```

**NOTE:** Masked ROM type devices do not support these instructions.

### 6.6.41 LDCD/LDED-Load Memory and Decrement

**LDCD/LDED** dst, src

**Operation:** dst ← src

rr ← rr – 1

You can use these instructions for user stacks or block transfers of data from program or data memory to the register file. A working register pair addresses specifies the address of the memory location. The contents of the source location are loaded into the destination location. The memory address is then decremented. The contents of the source are unaffected.

LDCD and LDED refer to external data memory respectively. The assembler makes "lrr" an even number for program memory and an odd number for data memory.

**Flags:** Does not affect any flags.

**Format:**

|     |           | Bytes | Cycles | Opcode<br>(Hex) | Addr Mode<br>dst | src |
|-----|-----------|-------|--------|-----------------|------------------|-----|
| opc | dst   src | 2     | 10     | E2              | r                | lrr |

**Examples:** Given: R6 = 10H, R7 = 33H, R8 = 12H, program memory location 1033H = 0CDH, and external data memory location 1033H = 0DDH:

LDCD R8, @RR6 ; 0CDH (contents of program memory location 1033H) is loaded  
; into R8 and RR6 is decremented by one  
; R8 = 0CDH, R6 = 10H, R7 = 32H (RR6 ← RR6 – 1)

LDED R8, @RR6 ; 0DDH (contents of data memory location 1033H) is loaded  
; into R8 and RR6 is decremented by one (RR6 ← RR6 – 1)  
; R8 = 0DDH, R6 = 10H, R7 = 32H

### 6.6.42 LDCI/LDEI-Load Memory and Increment

**LDCI/LDEI**     dst, src

**Operation:**     dst ← src

rr ← rr + 1

You can use these instructions for user stacks or block transfers of data from program or data memory to the register file. A working register pair specifies the address of the memory location. The contents of the source location are loaded into the destination location. The memory address is then incremented automatically. The contents of the source are unaffected.

LDCI and LDEI refer to external data memory respectively. The assembler makes "lrr" even for program memory and odd for data memory.

**Flags:**            Does not affect any flags.

**Format:**

|     |           | Bytes | Cycles | Opcode<br>(Hex) | Addr Mode<br>dst | src |
|-----|-----------|-------|--------|-----------------|------------------|-----|
| opc | dst   src | 2     | 10     | E3              | r                | lrr |

**Examples:**     Given: R6 = 10H, R7 = 33H, R8 = 12H, program memory locations 1033H = 0CDH and 1034H = 0C5H; external data memory locations 1033H = 0DDH and 1034H = 0D5H:

```
LDCI   R8,@RR6           ; 0CDH (contents of program memory location 1033H) is loaded
                          ; into R8 and RR6 is incremented by one (RR6 ← RR6 + 1)
                          ; R8 = 0CDH, R6 = 10H, R7 = 34H
```

```
LDEI   R8,@RR6           ; 0DDH (contents of data memory location 1033H) is loaded
                          ; into R8 and RR6 is incremented by one (RR6 ← RR6 + 1)
                          ; R8 = 0DDH, R6 = 10H, R7 = 34H
```



### 6.6.43 LDCPD/LDEPD-Load Memory with Pre-Decrement

**LDCPD/  
LDEPD**      dst, src

**Operation:**     $rr \leftarrow rr - 1$   
  
                    $dst \leftarrow src$

You can use these instructions for block transfers of data from program or data memory from the register file. A working register pair specifies the address of the memory location. It decrements the address of the memory location. The contents of the source location are then loaded into the destination location. The contents of the source are unaffected.

LDCPD and LDEPD refer to external data memory respectively. The assembler makes "lrr" an even number for program memory and an odd number for external data memory.

**Flags:**            Does not affect any flags.

**Format:**

|     |           | Bytes | Cycles | Opcode<br>(Hex) | Addr Mode<br>dst | src |
|-----|-----------|-------|--------|-----------------|------------------|-----|
| opc | src   dst | 2     | 14     | F2              | lrr              | r   |

**Examples:**      Given: R0 = 77H, R6 = 30H and R7 = 00H:

```
LDCPD  @RR6, R0      ; (RR6 ← RR6 - 1)
                       ; 77H (contents of R0) is loaded into program memory location
                       ; 2FFFH (3000H - 1H)
                       ; R0 = 77H, R6 = 2FH, R7 = 0FFH

LDEPD  @RR6, R0      ; (RR6 ← RR6 - 1)
                       ; 77H (contents of R0) is loaded into external data memory
                       ; location 2FFFH (3000H - 1H)
                       ; R0 = 77H, R6 = 2FH, R7 = 0FFH
```

### 6.6.44 LDCPI/LDEPI-Load Memory with Pre-Increment

**LDCPI/  
LDEPI**      dst, src

**Operation:**     $rr \leftarrow rr + 1$   
  
                   $dst \leftarrow src$

You can use these instructions for block transfers of data from program or data memory from the register file. A working register pair specifies the address of the memory location. It increments the address of the memory location. The contents of the source location are loaded into the destination location. The contents of the source are unaffected.

LDCPI refers to program memory and LDEPI refers to external data memory. The assembler makes "lrr" an even number for program memory and an odd number for data memory.

**Flags:**            Does not affect any flags.

**Format:**

|     |           | Bytes | Cycles | Opcode<br>(Hex) | Addr Mode<br>dst | src |
|-----|-----------|-------|--------|-----------------|------------------|-----|
| opc | src   dst | 2     | 14     | F3              | lrr              | r   |

**Examples:**      Given: R0 = 7FH, R6 = 21H and R7 = 0FFH:

```

LDCPI  @RR6, R0      ;      (RR6 ← RR6 + 1)
                          ;      7FH (contents of R0) is loaded into program memory
                          ;      Location 2200H (21FFH + 1H)
                          ;      R0 = 7FH, R6 = 22H, R7 = 00H

LDEPI  @RR6, R0      ;      (RR6 ← RR6 + 1)
                          ;      7FH (contents of R0) is loaded into external data memory
                          ;      Location 2200H (21FFH + 1H)
                          ;      R0 = 7FH, R6 = 22H, R7 = 00H
    
```

### 6.6.45 LDW-Load Word

**LDW** dst, src

**Operation:** dst ← src

The contents of the source (a word) are loaded into the destination. The contents of the source are unaffected.

**Flags:** Does not affect any flags.

**Format:**

|     |     |     | Bytes | Cycles | Opcode<br>(Hex) | Addr Mode<br>dst | src |
|-----|-----|-----|-------|--------|-----------------|------------------|-----|
| opc | src | dst | 3     | 8      | C4              | RR               | RR  |
|     |     |     |       | 8      | C5              | RR               | IR  |
| opc | dst | src | 4     | 8      | C6              | RR               | IML |

**Examples:** Given: R4 = 06H, R5 = 1CH, R6 = 05H, R7 = 02H, register 00H = 1AH, register 01H = 02H, register 02H = 03H, and register 03H = 0FH:

```
LDW  RR6, RR4    →  R6 = 06H, R7 = 1CH, R4 = 06H, R5 = 1CH
LDW  00H, 02H    →  Register 00H = 03H, register 01H = 0FH,
                    register 02H = 03H, register 03H = 0FH

LDW  RR2, @R7    →  R2 = 03H, R3 = 0FH,
LDW  04H, @01H   →  Register 04H = 03H, register 05H = 0FH
LDW  RR6, #1234H →  R6 = 12H, R7 = 34H
LDW  02H, #0FEDH →  Register 02H = 0FH, register 03H = 0EDH
```

In the second example, the statement "LDW 00H,02H" loads the contents of the source word 02H, 03H into the destination word 00H, 01H. This leaves the value 03H in general register 00H and the value 0FH in register 01H.

The other examples show how to use the LDW instruction with various addressing modes and formats.

### 6.6.46 MULT-Multiply (Unsigned)

**MULT** dst, src

**Operation:** dst ← dst × src

The source operand (8 bits) multiplies the 8-bit destination operand (even register of the register pair) It stores the product (16 bits) in the register pair that destination address specifies.

- Flags:**
- C:** Set if result is > 255; otherwise it clears.
  - Z:** Set if the result is "0"; otherwise it clears.
  - S:** Set if MSB of the result is a "1"; otherwise it clears.
  - V:** Cleared.
  - D:** Does not affect.
  - H:** Does not affect.

**Format:**

|     |     |     | Bytes | Cycles | Opcode<br>(Hex) | Addr Mode<br>dst | src |
|-----|-----|-----|-------|--------|-----------------|------------------|-----|
| opc | src | dst | 3     | 22     | 84              | RR               | R   |
|     |     |     |       | 22     | 85              | RR               | IR  |
|     |     |     |       | 22     | 86              | RR               | IM  |

**Examples:** Given: Register 00H = 20H, register 01H = 03H, register 02H = 09H, register 03H = 06H:

```
MULT 00H, 02H    → Register 00H = 01H, register 01H = 20H, register 02H = 09H
MULT 00H, @01H   → Register 00H = 00H, register 01H = 0C0H
MULT 00H, #30H   → Register 00H = 06H, register 01H = 00H
```

In the first example, the statement "MULT 00H, 02H" multiplies the 8-bit destination operand (in the register 00H of the register pair 00H, 01H) by the source register 02H operand (09H). The 16-bit product, 0120H, is stored in the register pair 00H, 01H.

6.6.47 NEXT-Next

NEXT

Operation: PC ← @ IP

IP ← IP + 2

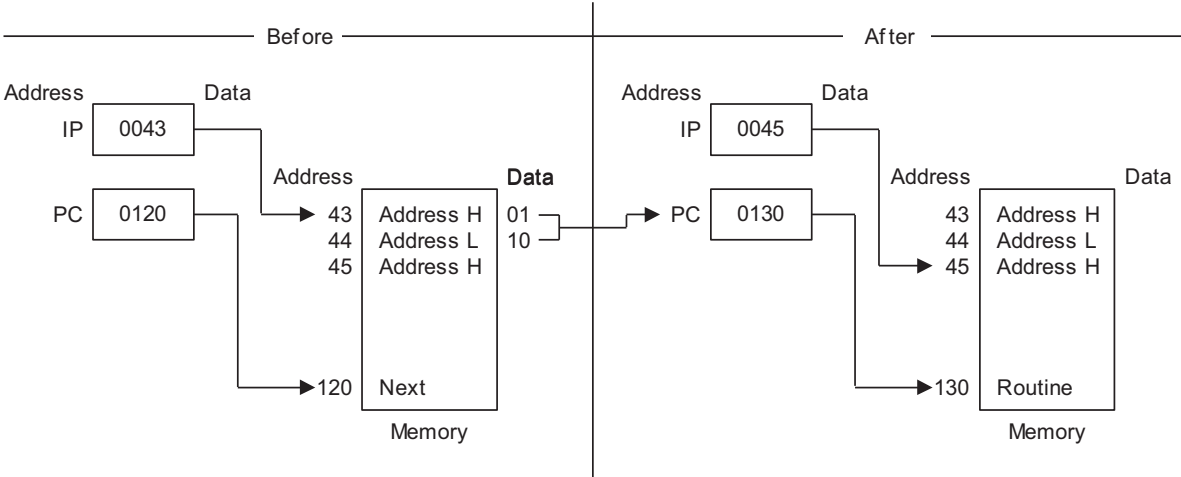
The NEXT instruction is useful when implementing threaded-code languages. The program memory word that is pointed to by the instruction pointer is loaded into the program counter. The instruction pointer is then incremented by two.

Flags: Does not affect any flags.

Format:

|     | Bytes | Cycles | Opcode (Hex) |
|-----|-------|--------|--------------|
| opc | 1     | 10     | 0F           |

Example: The following diagram shows one example of how to use the NEXT instruction.



### 6.6.48 NOP-No Operation

#### NOP

**Operation:** No action is performed when the CPU executes this instruction. Typically, one or more NOPs are executed in sequence in order to effect a timing delay of variable duration.

**Flags:** Does not affect any flags.

#### Format:

|   | Bytes | Cycles | Opcode<br>(Hex) |    |
|---|-------|--------|-----------------|----|
| <table border="1"><tr><td>opc</td></tr></table> | opc   | 1      | 4               | FF |
| opc   |       |        |                 |    |

**Example:** When the instruction  
NOP  
is encountered in a program, operation does not occur. Instead, there is a delay in instruction execution time.

### 6.6.49 OR-Logical OR

**OR** dst, src

**Operation:** dst ← dst OR src

The source operand is logically ORed with the destination operand and the result is stored in the destination. The contents of the source are unaffected. The OR operation results in a "1" being stored whenever either of the corresponding bits in the two operands is a "1"; otherwise it stores a "0".

- Flags:**
- C:** Does not affect.
  - Z:** Set if the result is "0"; otherwise it clears.
  - S:** Set if the result bit 7 is set; otherwise it clears.
  - V:** Always cleared to "0".
  - D:** Does not affect.
  - H:** Does not affect.

**Format:**

|     |           |     | Bytes | Cycles | Opcode<br>(Hex) | Addr Mode<br>dst | src |
|-----|-----------|-----|-------|--------|-----------------|------------------|-----|
| opc | dst   src |     | 2     | 4      | 42              | r                | r   |
|     |           |     |       | 6      | 43              | r                | lr  |
| opc | src       | dst | 3     | 6      | 44              | R                | R   |
|     |           |     |       | 6      | 45              | R                | IR  |
| opc | dst       | src | 3     | 6      | 46              | R                | IM  |

**Examples:** Given: R0 = 15H, R1 = 2AH, R2 = 01H, register 00H = 08H, register 01H = 37H, and register 08H = 8AH:

```

OR    R0, R1      →    R0 = 3FH, R1 = 2AH
OR    R0, @R2     →    R0 = 37H, R2 = 01H, register 01H = 37H
OR    00H, 01H    →    Register 00H = 3FH, register 01H = 37H
OR    01H, @00H   →    Register 00H = 08H, register 01H = 0BFH
OR    00H, #02H   →    Register 00H = 0AH
    
```

In the first example, when working register R0 contains the value 15H and register R1 contains the value 2AH, the statement "OR R0, R1" logical-ORs the R0 and R1 register contents and stores the result (3FH) in destination register R0.

The other examples show the use of the logical OR instruction with the various addressing modes and formats.

### 6.6.50 POP-Pop from Stack

**POP** dst

**Operation:** dst ← @SP

SP ← SP + 1

The contents of the location addressed by the stack pointer are loaded into the destination. The stack pointer is then incremented by one.

**Flags:** No flags affected.

**Format:**

|     |     | Bytes | Cycles | Opcode<br>(Hex) | Addr Mode<br>dst |
|-----|-----|-------|--------|-----------------|------------------|
| opc | dst | 2     | 8      | 50              | R                |
|     |     |       | 8      | 51              | IR               |

**Examples:** Given: Register 00H = 01H, register 01H = 1BH, SPH (0D8H) = 00H, SPL (0D9H) = 0FBH and stack register 0FBH = 55H:

POP 00H → Register 00H = 55H, SP = 00FCH

POP @00H → Register 00H = 01H, register 01H = 55H, SP = 00FCH

In the first example, general register 00H contains the value 01H. The statement "POP 00H" loads the contents of location 00FBH (55H) into destination register 00H and then increments the stack pointer by one. Register 00H then contains the value 55H and the SP points to location 00FCH.



### 6.6.51 POPUD-Pop User Stack (Decrementing)

**POPUD** dst, src

**Operation:** dst ← src

IR ← IR – 1

You can use this instruction for user-defined stacks in the register file. It loads the contents of the register file location that the user stack pointer addresses into the destination. The user stack pointer is then decremented.

**Flags:** Does not affect any flags.

**Format:**

|     |     |     | Bytes | Cycles | Opcode<br>(Hex) | Addr Mode<br>dst | src |
|-----|-----|-----|-------|--------|-----------------|------------------|-----|
| opc | src | dst | 3     | 8      | 92              | R                | IR  |

**Example:** Given: Register 00H = 42H (user stack pointer register), register 42H = 6FH, and register 02H = 70H:

POPUD 02H, @00H → Register 00H = 41H, register 02H = 6FH, register 42H = 6FH

If general register 00H contains the value 42H and register 42H contains the value 6FH, the statement "POPUD 02H, @00H" loads the contents of register 42H into the destination register 02H. The user stack pointer is then decremented by one by leaving the value 41H.

### 6.6.52 POPUI-Pop User Stack (Incrementing)

**POPUI** dst, src

**Operation:** dst ← src

IR ← IR + 1

You can use the POPUI instruction for user-defined stacks in the register file. The contents of the register file location addressed by the user stack pointer are loaded into the destination. The user stack pointer is then incremented.

**Flags:** Does not affect any flags.

**Format:**

|     |     |     | Bytes | Cycles | Opcode<br>(Hex) | Addr Mode<br>dst | src |
|-----|-----|-----|-------|--------|-----------------|------------------|-----|
| opc | src | dst | 3     | 8      | 93              | R                | IR  |

**Example:** Given: Register 00H = 01H and register 01H = 70H:

POPUI 02H, @00H → Register 00H = 02H, register 01H = 70H, register 02H = 70H

If general register 00H contains the value 01H and register 01H the value 70H, the statement "POPUI 02H, @00H" loads the value 70H into the destination general register 02H. Then, it increments the user stack pointer (register 00H) by one, changing its value from 01H to 02H.

### 6.6.53 PUSH-Push to Stack

**PUSH**            src

**Operation:**     $SP \leftarrow SP - 1$

$@SP \leftarrow src$

A PUSH instruction decrements the stack pointer value and loads the contents of the source (src) into the location The decremented stack pointer addresses the location. The operation then adds the new value to the top of the stack.

**Flags:**            Does not affect any flags.

**Format:**

|     |     | Bytes | Cycles                                   | Opcode<br>(Hex) | Addr Mode<br>dst |
|-----|-----|-------|--|-----------------|------------------|
| opc | src | 2     | 8 (Internal clock)<br>8 (External clock) | 70              | R                |
|     |     |       | 8 (Internal clock)<br>8 (External clock) | 71              | IR               |

**Examples:**        Given: Register 40H = 4FH, register 4FH = 0AAH, SPH = 00H and SPL = 00H:

PUSH    40H        →        Register 40H = 4FH, stack register 0FFH = 4FH,  
SPH = 0FFH, SPL = 0FFH

PUSH    @40H      →        Register 40H = 4FH, register 4FH = 0AAH, stack register  
0FFH = 0AAH, SPH = 0FFH, SPL = 0FFH

In the first example, when the stack pointer contains the value 0000H, and general register 40H contains the value 4FH, the statement "PUSH 40H" decrements the stack pointer from 0000 to 0FFFFH. It then loads the contents of register 40H into location 0FFFFH and adds this new value to the top of the stack.

### 6.6.54 PUSHUD-Push User Stack (Decrementing)

**PUSHUD** dst, src

**Operation:**  $IR \leftarrow IR - 1$

$dst \leftarrow src$

You can use this instruction to address user-defined stacks in the register file. PUSHUD decrements the user stack pointer and loads the contents of the source into the register. The decremented stack pointer addresses the register.

**Flags:** Does not affect any flags.

**Format:**

|     |     |     | Bytes | Cycles | Opcode<br>(Hex) | Addr Mode<br>dst | src |
|-----|-----|-----|-------|--------|-----------------|------------------|-----|
| opc | dst | src | 3     | 8      | 82              | IR               | R   |

**Example:** Given: Register 00H = 03H, register 01H = 05H, and register 02H = 1AH:

`PUSHUD @00H, 01H` → Register 00H = 02H, register 01H = 05H, register 02H = 05H

If the user stack pointer (register 00H, for example) contains the value 03H, the statement "PUSHUD @00H, 01H" decrements the user stack pointer by one by leaving the value 02H. It then loads the 01H register value, 05H, into the register. The decremented user stack pointer addresses the register.

### 6.6.55 PUSHUI-Push User Stack (Incrementing)

**PUSHUI** dst, src

**Operation:** IR ← IR + 1

dst ← src

You can use this instruction for user-defined stacks in the register file. PUSHUI increments the user stack pointer and then loads the contents of the source into the register location. The incremented user stack pointer addresses the register location.

**Flags:** Does not affect any flags.

**Format:**

|     |     |     | Bytes | Cycles | Opcode<br>(Hex) | Addr Mode<br>dst | src |
|-----|-----|-----|-------|--------|-----------------|------------------|-----|
| opc | dst | src | 3     | 8      | 83              | IR               | R   |

**Example:** Given: Register 00H = 03H, register 01H = 05H, and register 04H = 2AH:

PUSHUI @00H, 01H → Register 00H = 04H, register 01H = 05H, register 04H = 05H

If the user stack pointer (register 00H, for example) contains the value 03H, the statement "PUSHUI @00H, 01H" increments the user stack pointer by one by leaving the value 04H. It then loads the 01H register value, 05H, into the location. The incremented user stack pointer addresses the location.

### 6.6.56 RCF-Reset Carry Flag

**RCF** RCF

**Operation:**  $C \leftarrow 0$

The carry flag is cleared to logic zero, regardless of its previous value.

**Flags:** **C:** Cleared to "0".

Does not affect any other flags.

**Format:**

|     | Bytes | Cycles | Opcode<br>(Hex) |
|-----|-------|--------|-----------------|
| opc | 1     | 4      | CF              |

**Example:** Given:  $C = "1"$  or  $"0"$ :

The instruction RCF clears the carry flag (C) to logic zero.

### 6.6.57 RET-Return

#### RET

**Operation:** PC ← @SP

SP ← SP + 2

Normally, you can use the RET instruction to return to the previously executing procedure at the end of a procedure. A CALL instruction enters the procedure. The contents of the location that the stack pointer addresses are popped into the program counter. The next statement that is executed is the one that the new program counter value addresses.

**Flags:** Does not affect any flags.

#### Format:

|     | Bytes | Cycles                                    | Opcode (Hex) |
|-----|-------|---|--------------|
| opc | 1     | 8 (Internal stack)<br>10 (Internal stack) | AF           |

**Example:** Given: SP = 00FCH, (SP) = 101AH, and PC = 1234:

**RET** → PC = 101AH, SP = 00FEH

The statement "RET" pops the contents of stack pointer location 00FCH (10H) into the high byte of the program counter. The stack pointer then pops the value in location 00FEH (1AH) into the low byte of PC and it executes the instruction at location 101AH. The stack pointer now points to memory location 00FEH.

### 6.6.58 RL-Rotate Left

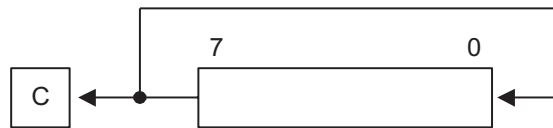
**RL**            dst

**Operation:**     $C \leftarrow \text{dst}(7)$

$\text{dst}(0) \leftarrow \text{dst}(7)$

$\text{dst}(n + 1) \leftarrow \text{dst}(n), n = 0-6$

The contents of the destination operand are rotated left one bit position. The initial value of bit 7 is moved to the bit zero (LSB) position and also replaces the carry flag.



- Flags:**
- C:** Set if the bit rotated from the most significant bit position (bit 7) was "1".
  - Z:** Set if the result is "0"; otherwise it clears.
  - S:** Set if the result bit 7 is set; otherwise it clears.
  - V:** Set if arithmetic overflow occurred; otherwise it clears.
  - D:** Does not affect.
  - H:** Does not affect.

**Format:**

|     |     | Bytes | Cycles | Opcode (Hex) | Addr Mode |
|-----|-----|-------|--------|--------------|-----------|
| opc | dst | 2     | 4      | 90           | R         |
|     |     |       | 4      | 91           | IR        |

**Examples:**    Given: Register 00H = 0AAH, register 01H = 02H and register 02H = 17H:

RL    00H    →    Register 00H = 55H, C = "1"  
 RL    @01H    →    Register 01H = 02H, register 02H = 2EH, C = "0"

In the first example, when general register 00H contains the value 0AAH (10101010B), the statement "RL 00H" rotates the 0AAH value left one bit position by leaving the new value 55H (01010101B) and setting the carry and overflow flags.



### 6.6.59 RLC-Rotate Left Through Carry

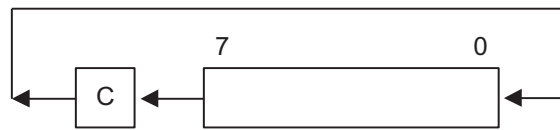
**RLC**            dst

**Operation:**    dst (0) ← C

C ← dst (7)

dst (n + 1) ← dst (n), n = 0-6

The contents of the destination operand with the carry flag are rotated left one bit position. The initial value of bit 7 replaces the carry flag (C); the initial value of the carry flag replaces bit zero.



- Flags:**
- C:** Sets if the bit rotated from the most significant bit position (bit 7) was "1".
  - Z:** Sets if the result is "0"; otherwise it clears.
  - S:** Sets if the result bit 7 is set; otherwise it clears.
  - V:** Sets if arithmetic overflow occurred, that is, if the sign of the destination changed during rotation; otherwise it clears.
  - D:** Does not affect.
  - H:** Does not affect.

**Format:**

|     |     | Bytes | Cycles | Opcode (Hex) | Addr Mode |
|-----|-----|-------|--------|--------------|-----------|
| opc | dst | 2     | 4      | 10           | R         |
|     |     |       | 4      | 11           | IR        |

**Examples:**    Given: Register 00H = 0AAH, register 01H = 02H, and register 02H = 17H, C = "0":

```
RLC 00H            Register 00H = 54H, C = "1"
RLC @01H           Register 01H = 02H, register 02H = 2EH, C = "0"
```

In the first example, when general register 00H has the value 0AAH (10101010B), the statement "RLC 00H" rotates 0AAH 1 bit position to the left. The initial value of bit 7 sets the carry flag and the initial value of the C flag replaces bit 0 of register 00H by leaving the value 55H (01010101B). The MSB of register 00H resets the carry flag to "1" and sets the overflow flag.

### 6.6.60 RR-Rotate Right

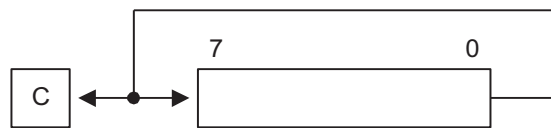
**RR** dst

**Operation:**  $C \leftarrow \text{dst}(0)$

$\text{dst}(7) \leftarrow \text{dst}(0)$

$\text{dst}(n) \leftarrow \text{dst}(n + 1), n = 0-6$

The contents of the destination operand are rotated right one bit position. The initial value of bit zero (LSB) is moved to bit 7 (MSB) and also replaces the carry flag (C).



- Flags:**
- C:** Sets if the bit rotated from the least significant bit position (bit zero) was "1".
  - Z:** Sets if the result is "0"; otherwise it clears.
  - S:** Sets if the result bit 7 is set; otherwise it clears.
  - V:** Sets if arithmetic overflow occurred, that is, if the sign of the destination changed during rotation; otherwise it clears.
  - D:** Does not affect.
  - H:** Does not affect.

**Format:**

|     |     | Bytes | Cycles | Opcode<br>(Hex) | Addr Mode<br>dst |
|-----|-----|-------|--------|-----------------|------------------|
| opc | dst | 2     | 4      | E0              | R                |
|     |     |       | 4      | E1              | IR               |

**Examples:** Given: Register 00H = 31H, register 01H = 02H, and register 02H = 17H:

```
RR    00H           Register 00H = 98H, C = "1"
RR    @01H         Register 01H = 02H, register 02H = 8BH, C = "1"
```

In the first example, when general register 00H contains the value 31H (00110001B), the statement "RR 00H" rotates this value one bit position to the right. It moves the initial value of bit zero to bit 7 by leaving the new value 98H (10011000B) in the destination register. The initial bit zero also resets the C flag to "1" and the sign flag and overflow flag are also set to "1".

### 6.6.61 RRC-Rotate Right through Carry

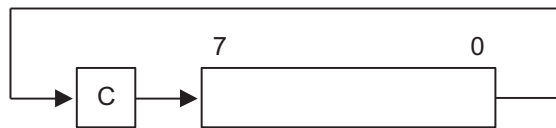
**RRC** dst

**Operation:** dst (7) ← C

C ← dst (0)

dst (n) ← dst (n + 1), n = 0-6

The contents of the destination operand and the carry flag are rotated right one bit position. The initial value of bit zero (LSB) replaces the carry flag; the initial value of the carry flag replaces bit 7 (MSB).



- Flags:**
- C:** Sets if the bit rotated from the least significant bit position (bit zero) was "1".
  - Z:** Sets if the result is "0" otherwise it clears.
  - S:** Sets if the result bit 7 is set; otherwise it clears.
  - V:** Sets if arithmetic overflow occurred, that is, if the sign of the destination changed during rotation; otherwise it clears.
  - D:** Does not affect.
  - H:** Does not affect.

**Format:**

|     |     | Bytes | Cycles | Opcode<br>(Hex) | Addr Mode<br>dst |
|-----|-----|-------|--------|-----------------|------------------|
| opc | dst | 2     | 4      | C0              | R                |
|     |     |       | 4      | C1              | IR               |

**Examples:** Given: Register 00H = 55H, register 01H = 02H, register 02H = 17H, and C = "0":

RRC 00H Register 00H = 2AH, C = "1"

RRC @01H Register 01H = 02H, register 02H = 0BH, C = "1"

In the first example, when general register 00H contains the value 55H (01010101B), the statement "RRC 00H" rotates this value 1 bit position to the right. The initial value of bit 0 ("1") replaces the carry flag and the initial value of the C flag ("1") replaces bit 7. This leaves the new value 2AH (00101010B) in destination register 00H. The sign flag and overflow flag are both cleared to "0".



6.6.62 SB0-Select Bank 0

**SB0**

**Operation:** BANK ← 0

The SB0 instruction clears the bank address flag in the FLAGS (FLAGS.0) to logic 0 by selecting the bank 0 register addressing in the set 1 area of the register file.

**Flags:** Does not affect any flags.

**Format:**

|   | Bytes | Cycles | Opcode<br>(Hex) |    |
|---|-------|--------|-----------------|----|
| <table border="1"><tr><td>opc</td></tr></table> | opc   | 1      | 4               | 4F |
| opc   |       |        |                 |    |

**Example:** The statement  
SB0

clears FLAGS.0 to "0" by selecting the bank 0 register addressing.

### 6.6.63 SB1-Select Bank 1

#### SB1

**Operation:** BANK ← 1

The SB1 instruction sets the bank address flag in the FLAGS (FLAGS.0) to logic one by selecting bank 1 register addressing in the set 1 area of the register file. (It does not implement bank 1 in some KS88-series microcontrollers.)

**Flags:** Does not affect any flags.

#### Format:

|     | Bytes | Cycles | Opcode<br>(Hex) |
|-----|-------|--------|-----------------|
| opc | 1     | 4      | 5F              |

**Example:** The statement

SB1

sets FLAGS.0 to "1" by selecting the bank 1 register addressing, when implemented.

### 6.6.64 SBC-Subtract With Carry

**SBC** dst, src

**Operation:** dst ← dst - src - c

The source operand, along with the current value of the carry flag, is subtracted from the destination operand and the result is stored in the destination. The contents of the source are unaffected. You can perform subtraction by adding the two's-complement of the source operand to the destination operand. In multiple precision arithmetic, this instruction permits the carry ("borrow") from the subtraction of the low-order operands to be subtracted from the subtraction of high-order operands.

- Flags:**
- C:** Sets if a borrow occurred (src > dst); otherwise it clears.
  - Z:** Sets if the result is "0"; otherwise it clears.
  - S:** Sets if the result is negative; otherwise it clears.
  - V:** Sets if arithmetic overflow occurred, that is, if the operands were of opposite sign and the sign of the result is the same as the sign of the source; otherwise it clears.
  - D:** Always set to "1".
  - H:** Clears when there is a carry from the most significant bit of the low-order four bits of the result; set otherwise, indicating a "borrow".

**Format:**

|  |     |           | Bytes | Cycles | Opcode (Hex) | Addr Mode | dst | src |   |    |
|--|-----|-----------|-------|--------|--------------|-----------|-----|-----|---|----|
| <table border="1" style="display: inline-table; vertical-align: middle;"> <tr> <td style="padding: 5px;">opc</td> <td style="padding: 5px;">dst   src</td> </tr> </table>                              | opc | dst   src |       |        | 2            | 4         | 32  | r   | r |    |
|  | opc | dst   src |       |        |              |           |     |     |   |    |
|  | 6   | 33        | r     | lr     |              |           |     |     |   |    |
| <table border="1" style="display: inline-table; vertical-align: middle;"> <tr> <td style="padding: 5px;">opc</td> <td style="padding: 5px;">src</td> <td style="padding: 5px;">dst</td> </tr> </table> | opc | src       | dst   |        |              | 3         | 6   | 34  | R | R  |
|  | opc | src       | dst   |        |              |           |     |     |   |    |
|  | 6   | 35        | R     | IR     |              |           |     |     |   |    |
| <table border="1" style="display: inline-table; vertical-align: middle;"> <tr> <td style="padding: 5px;">opc</td> <td style="padding: 5px;">dst</td> <td style="padding: 5px;">src</td> </tr> </table> | opc | dst       | src   |        |              | 3         | 6   | 36  | R | IM |
| opc  | dst | src       |       |        |              |           |     |     |   |    |

**Examples:** Given: R1 = 10H, R2 = 03H, C = "1", register 01H = 20H, register 02H = 03H, and register 03H = 0AH:

```

SBC   R1, R2           R1 = 0CH, R2 = 03H
SBC   R1, @R2         R1 = 05H, R2 = 03H, register 03H = 0AH
SBC   01H, 02H       Register 01H = 1CH, register 02H = 03H
SBC   01H, @02H      Register 01H = 15H, register 02H = 03H, register 03H = 0AH
SBC   01H, #8AH      Register 01H = 95H; C, S, and V = "1"
    
```

In the first example, when working register R1 contains the value 10H and register R2 the value 03H, the statement "SBC R1, R2" subtracts the source value (03H) and the C flag value ("1") from the destination (10H) and then stores the result (0CH) in register R1.

### 6.6.65 SCF-Set Carry Flag

#### SCF

**Operation:**  $C \leftarrow 1$

The carry flag (C) is set to logic one, regardless of its previous value.

**Flags:** **C:** Set to "1".

Does not affect any other flags.

#### Format:

|   | Bytes | Cycles | Opcode<br>(Hex) |    |
|---|-------|--------|-----------------|----|
| <table border="1"><tr><td>opc</td></tr></table> | opc   | 1      | 4               | DF |
| opc   |       |        |                 |    |

**Example:** The statement

SCF

sets the carry flag to logic 1.

### 6.6.66 SRA-Shift Right Arithmetic

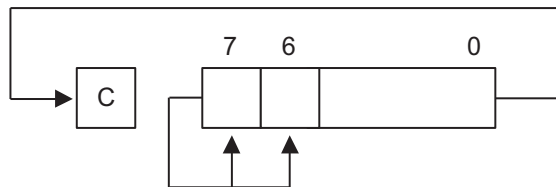
**SRA**            dst

**Operation:**    dst (7) ← dst (7)

C ← dst (0)

dst (n) ← dst (n + 1), n = 0-6

An arithmetic shift-right of one bit position is performed on the destination operand. Bit zero (the LSB) replaces the carry flag. The value of bit 7 (the sign bit) is unchanged and is shifted into bit position 6.



- Flags:**
- C:** Sets if the bit shifted from the LSB position (bit zero) was "1".
  - Z:** Sets if the result is "0"; otherwise it clears.
  - S:** Sets if the result is negative; otherwise it clears.
  - V:** Always cleared to "0".
  - D:** Does not affect.
  - H:** Does not affect.

**Format:**

|     |     | Bytes | Cycles | Opcode<br>(Hex) | Addr Mode<br>dst |
|-----|-----|-------|--------|-----------------|------------------|
| opc | dst | 2     | 4      | D0              | R                |
|     |     |       | 4      | D1              | IR               |

**Examples:**    Given: Register 00H = 9AH, register 02H = 03H, register 03H = 0BCH, and C = "1":

SRA    00H                    Register 00H = 0CD, C = "0"

SRA    @02H                  Register 02H = 03H, register 03H = 0DEH, C = "0"

In the first example, when general register 00H contains the value 9AH (10011010B), the statement "SRA 00H" shifts the bit values in register 00H right 1 bit position. Bit zero ("0") clears the C flag and bit 7 ("1") is then shifted into the bit 6 position (bit 7 does not change). This leaves the value 0CDH (11001101B) in destination register 00H.



### 6.6.67 SRP/SRP0/SRP1-Set Register Pointer

**SRP** src

**SRP0** src

**SRP1** src

**Operation:**

|                                      |           |            |
|--------------------------------------|-----------|------------|
| If src (1) = 1 and src (0) = 0 then: | RP0 (3–7) | src (3–7)  |
| If src (1) = 0 and src (0) = 1 then: | RP1 (3–7) | src (3–7)  |
| If src (1) = 0 and src (0) = 0 then: | RP0 (4–7) | src (4–7), |
|                                      | RP0 (3)   | 0          |
|                                      | RP1 (4–7) | src (4–7), |
|                                      | RP1 (3)   | 1          |

The source data bits 1 and 0 (LSB) determine whether to write one or both of the register pointers, RP0 and RP1. Bits 3–7 of the selected register pointer are written unless both register pointers are selected. RP0.3 is then cleared to logic zero and RP1.3 is set to logic one.

**Flags:** Does not affect any flags.

**Format:**

|     |     | Bytes | Cycles | Opcode<br>(Hex) | Addr Mode<br>src |
|-----|-----|-------|--------|-----------------|------------------|
| opc | src | 2     | 4      | 31              | IM               |

**Examples:** The statement

SRP # 40H

Sets register pointer 0 (RP0) at location 0D6H to 40H and register pointer 1 (RP1) at location 0D7H to 48H.

The statement "SRP0 #50H" sets RP0 to 50H, and the statement "SRP1 #68H" sets RP1 to 68H.

### 6.6.68 STOP-Stop Operation

#### STOP

#### Operation:

The STOP instruction stops both the CPU and system clock and causes the microcontroller to enter Stop mode. During Stop mode, the contents of on-chip CPU registers, peripheral registers, and I/O port control and data registers are retained. An external reset operation or external interrupts release the Stop mode. For the reset operation, the RESET pin must be held to Low level until the required oscillation stabilization interval has elapsed.

**Flags:** Does not affect any flags.

#### Format:

|     | Bytes | Cycles | Opcode<br>(Hex) | Addr Mode<br>dst | src |
|-----|-------|--------|-----------------|------------------|-----|
| opc | 1     | 4      | 7F              | -                | -   |

**Example:** The statement

STOP

Halts all microcontroller operations.

### 6.6.69 SUB-Subtract

**SUB** dst, src

**Operation:** dst ← dst-src

The source operand is subtracted from the destination operand and the result is stored in the destination. The contents of the source are unaffected. Subtraction is performed by adding the two's complement of the source operand to the destination operand.

- Flags:**
- C:** Sets if a "borrow" occurred; otherwise it clears.
  - Z:** Sets if the result is "0"; otherwise it clears.
  - S:** Sets if the result is negative; otherwise it clears.
  - V:** Sets if arithmetic overflow occurred, that is, if the operands were of opposite signs and sign of the result is of the same as the sign of the source operand; otherwise it clears.
  - D:** Always set to "1".
  - H:** Clears if there is a carry from the most significant bit of the low-order four bits of the result; set otherwise indicating a "borrow".

**Format:**

|  |     | Bytes     | Cycles | Opcode (Hex) | Addr Mode | dst | src |   |   |    |
|--|-----|-----------|--------|--------------|-----------|-----|-----|---|---|----|
| <table border="1" style="display: inline-table; vertical-align: middle;"> <tr> <td style="padding: 5px;">opc</td> <td style="padding: 5px;">dst   src</td> </tr> </table>                              | opc | dst   src |        | 2            | 4         | 22  |     | r | r |    |
|  | opc | dst   src |        |              |           |     |     |   |   |    |
|  |     |           | 6      | 23           |           | r   | lr  |   |   |    |
| <table border="1" style="display: inline-table; vertical-align: middle;"> <tr> <td style="padding: 5px;">opc</td> <td style="padding: 5px;">src</td> <td style="padding: 5px;">dst</td> </tr> </table> | opc | src       | dst    |              | 3         | 6   | 24  |   | R | R  |
|  | opc | src       | dst    |              |           |     |     |   |   |    |
|  |     |           | 6      | 25           |           | R   | IR  |   |   |    |
| <table border="1" style="display: inline-table; vertical-align: middle;"> <tr> <td style="padding: 5px;">opc</td> <td style="padding: 5px;">dst</td> <td style="padding: 5px;">src</td> </tr> </table> | opc | dst       | src    |              | 3         | 6   | 26  |   | R | IM |
| opc  | dst | src       |        |              |           |     |     |   |   |    |

**Examples:** Given: R1 = 12H, R2 = 03H, register 01H = 21H, register 02H = 03H, register 03H = 0AH:

|     |           |   |
|-----|-----------|---|
| SUB | R1, R2    | R1 = 0FH, R2 = 03H                          |
| SUB | R1, @R2   | R1 = 08H, R2 = 03H                          |
| SUB | 01H, 02H  | Register 01H = 1EH, register 02H = 03H      |
| SUB | 01H, @02H | Register 01H = 17H, register 02H = 03H      |
| SUB | 01H, #90H | Register 01H = 91H; C, S, and V = "1"       |
| SUB | 01H, #65H | Register 01H = 0BCH; C and S = "1", V = "0" |

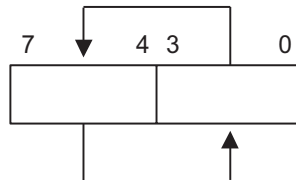
In the first example, when working register R1 contains the value 12H and when register R2 contains the value 03H, the statement "SUB R1, R2" subtracts the source value (03H) from the destination value (12H) and stores the result (0FH) in destination register R1.

### 6.6.70 SWAP-Swap Nibbles

**SWAP** dst

**Operation:** dst (0-3) ↔ dst (4-7)

The contents of the lower four bits and upper four bits of the destination operand are swapped.



- Flags:**
- C:** Does not define.
  - Z:** Sets if the result is "0"; otherwise it clears.
  - S:** Sets if the result bit 7 is set; otherwise it clears.
  - V:** Does not define.
  - D:** Does not affect.
  - H:** Does not affect.

**Format:**

|     |     | Bytes | Cycles | Opcode<br>(Hex) | Addr Mode<br>dst |
|-----|-----|-------|--------|-----------------|------------------|
| opc | dst | 2     | 4      | F0              | R                |
|     |     |       | 4      | F1              | IR               |

**Examples:** Given: Register 00H = 3EH, register 02H = 03H, and register 03H = 0A4H:

```
SWAP 00H      Register 00H = 0E3H
SWAP @02H     Register 02H = 03H, register 03H = 4AH
```

In the first example, when general register 00H contains the value 3EH (00111110B), the statement "SWAP 00H" swaps the lower and upper four bits (nibbles) in the 00H register by leaving the value 0E3H (11100011B).

### 6.6.71 TCM-Test Complement under Mask

**TCM** dst, src

**Operation:** (NOT dst) AND src

This instruction tests selected bits in the destination operand for a logic 1 value. You can specify the bits to be tested by setting a "1" bit in the corresponding position of the source operand (mask). The TCM statement complements the destination operand, which is then ANDed with the source mask. You can verify the zero (Z) flag to determine the result. The destination and source operands are unaffected.

- Flags:**
- C:** Does not affect.
  - Z:** Sets if the result is "0"; otherwise it clears.
  - S:** Sets if the result bit 7 is set; otherwise it clears.
  - V:** Always clears to "0".
  - D:** Does not affect.
  - H:** Does not affect.

**Format:**

|  |     | Bytes     | Cycles | Opcode<br>(Hex) | Addr Mode<br>dst | src |   |    |
|--|-----|-----------|--------|-----------------|------------------|-----|---|----|
| <table border="1" style="margin: auto;"> <tr> <td style="padding: 2px 10px;">opc</td> <td style="padding: 2px 10px;">dst   src</td> </tr> </table>                                   | opc | dst   src | 2      | 4               | 62               | r   | r |    |
|  | opc | dst   src |        |                 |                  |     |   |    |
| 6  | 63  | r         | lr     |                 |                  |     |   |    |
| <table border="1" style="margin: auto;"> <tr> <td style="padding: 2px 10px;">opc</td> <td style="padding: 2px 10px;">src</td> <td style="padding: 2px 10px;">dst</td> </tr> </table> | opc | src       | dst    | 3               | 6                | 64  | R | R  |
|  | opc | src       | dst    |                 |                  |     |   |    |
| 6  | 65  | R         | IR     |                 |                  |     |   |    |
| <table border="1" style="margin: auto;"> <tr> <td style="padding: 2px 10px;">opc</td> <td style="padding: 2px 10px;">dst</td> <td style="padding: 2px 10px;">src</td> </tr> </table> | opc | dst       | src    | 3               | 6                | 66  | R | IM |
| opc  | dst | src       |        |                 |                  |     |   |    |

**Examples:** Given: R0 = 0C7H, R1 = 02H, R2 = 12H, register 00H = 2BH, register 01H = 02H, and register 02H = 23H:

|     |           |  |
|-----|-----------|--|
| TCM | R0, R1    | R0 = 0C7H, R1 = 02H, Z = "1"   |
| TCM | R0, @R1   | R0 = 0C7H, R1 = 02H, register 02H = 23H, Z = "0"                       |
| TCM | 00H, 01H  | Register 00H = 2BH, register 01H = 02H, Z = "1"                        |
| TCM | 00H, @01H | Register 00H = 2BH, register 01H = 02H,<br>register 02H = 23H, Z = "1" |
| TCM | 00H, #34  | Register 00H = 2BH, Z = "0"  |

In the first example, when working register R0 contains the value 0C7H (11000111B) and register R1 the value 02H (00000010B), the statement "TCM R0, R1" tests bit 1 in the destination register for a "1" value. Because the mask value corresponds to the test bit, the Z flag is set to logic 1 and can be tested to determine the result of the TCM operation.

### 6.6.72 TM-Test under Mask

**TM** dst, src

**Operation:** dst AND src

This instruction tests selected bits in the destination operand for a logic 0 value. The bits to be tested are specified by setting a "1" bit in the corresponding position of the source operand (mask), which is ANDed with the destination operand. The zero (Z) flag can then be checked to determine the result. The destination and source operands are unaffected.

- Flags:**
- C:** Does not affect.
  - Z:** Set if the result is "0"; otherwise it clears.
  - S:** Set if the result bit 7 is set; otherwise it clears.
  - V:** Always reset to "0".
  - D:** Does not affect.
  - H:** Does not affect.

**Format:**

|     |           | Bytes | Cycles | Opcode<br>(Hex) | Addr Mode<br>dst | src |
|-----|-----------|-------|--------|-----------------|------------------|-----|
| opc | dst   src | 2     | 4      | 72              | r                | r   |
|     |           |       | 6      | 73              | r                | lr  |
| opc | src       | 3     | 6      | 74              | R                | R   |
|     |           |       | 6      | 75              | R                | IR  |
| opc | dst       | 3     | 6      | 76              | R                | IM  |

**Examples:** Given: R0 = 0C7H, R1 = 02H, R2 = 18H, register 00H = 2BH, register 01H = 02H, and register 02H = 23H:

|    |           |  |
|----|-----------|--|
| TM | R0, R1    | R0 = 0C7H, R1 = 02H, Z = "0"   |
| TM | R0, @R1   | R0 = 0C7H, R1 = 02H, register 02H = 23H, Z = "0"                       |
| TM | 00H, 01H  | Register 00H = 2BH, register 01H = 02H, Z = "0"                        |
| TM | 00H, @01H | Register 00H = 2BH, register 01H = 02H,<br>register 02H = 23H, Z = "0" |
| TM | 00H, #54H | Register 00H = 2BH, Z = "1"  |

In the first example when working register R0 contains the value 0C7H (11000111B) and register R1 the value 02H (00000010B), the statement "TM R0, R1" tests bit 1 in the destination register for a "0" value. Because the mask value does not match the test bit, the Z flag is cleared to logic 0 and can be tested to determine the result of the TM operation.

6.6.73 WFI-Wait for Interrupt

WFI

Operation:

The CPU is effectively halted until an interrupt occurs, except that DMA transfers can still take place during this wait state. The WFI status can be released by an internal interrupt that includes a fast interrupt.

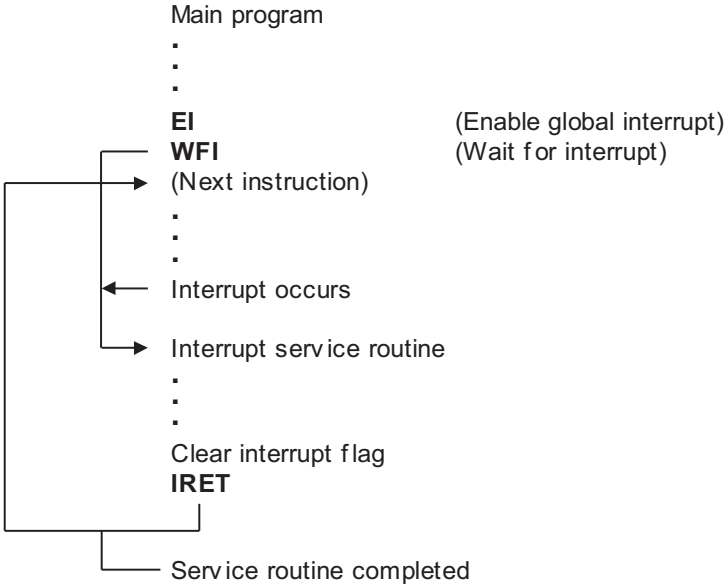
Flags: Does not affect any flags.

Format:

|     | Bytes | Cycles | Opcode (Hex) |
|-----|-------|--------|--------------|
| opc | 1     | 4n     | 3F           |

NOTE: (N = 1, 2, 3...)

Example: The following sample program structure shows the sequence of operations that follow a "WFI" statement:



### 6.6.74 XOR-Logical Exclusive OR

**XOR** dst, src

**Operation:** dst ← dst XOR src

The source operand is logically exclusive-ORed with the destination operand and the result is stored in the destination. The exclusive-OR operation results in a "1" bit being stored whenever the corresponding bits in the operands are different; otherwise, it stores a "0" bit.

- Flags:**
- C:** Does not affect.
  - Z:** Sets if the result is "0"; otherwise it clears.
  - S:** Sets if the result bit 7 is set; otherwise it clears.
  - V:** Always reset to "0".
  - D:** Does not affect.
  - H:** Does not affect.

**Format:**

|     |           | Bytes | Cycles | Opcode (Hex) | Addr Mode dst | src |
|-----|-----------|-------|--------|--------------|---------------|-----|
| opc | dst   src | 2     | 4      | B2           | r             | r   |
|     |           |       | 6      | B3           | r             | lr  |
| opc | src       | 3     | 6      | B4           | R             | R   |
|     |           |       | 6      | B5           | R             | IR  |
| opc | dst       | 3     | 6      | B6           | R             | IM  |

**Examples:** Given: R0 = 0C7H, R1 = 02H, R2 = 18H, register 00H = 2BH, register 01H = 02H, and register 02H = 23H:

|     |           |  |
|-----|-----------|--|
| XOR | R0, R1    | R0 = 0C5H, R1 = 02H  |
| XOR | R0, @R1   | R0 = 0E4H, R1 = 02H, register 02H = 23H                    |
| XOR | 00H, 01H  | Register 00H = 29H, register 01H = 02H                     |
| XOR | 00H, @01H | Register 00H = 08H, register 01H = 02H, register 02H = 23H |
| XOR | 00H, #54H | Register 00H = 7FH   |

R1  
R1 value with

In the first example when working register R0 contains the value 0C7H and when register contains the value 02H, the statement "XOR R0, R1" logically exclusive-ORs the the R0 value and stores the result (0C5H) in the destination register R0.



# 7

## Clock Circuit

### 7.1 Overview

By smart option (3FH.2–.0 in ROM), you can select internal RC oscillator, external RC oscillator, or external oscillator. An internal RC oscillator source provides a typical 8 MHz, 4 MHz, 1 MHz or 0.5 MHz depending on smart option.

An external RC oscillation source provides a typical 4 MHz clock for S3F8S19/F8S15. An internal capacitor supports the RC oscillator circuit. An external crystal or ceramic oscillation source provides a maximum 12 MHz clock. The XIN and XOUT pins connect the oscillation source to the on-chip clock circuit. [Figure 7-1](#), [Figure 7-2](#), and [Figure 7-3](#) illustrate simplified external RC oscillator and crystal/ceramic oscillator circuits.

### 7.2 System Clock Circuit

The components of system clock circuit are:

- External crystal, ceramic resonator, RC oscillation source, or an external clock source
- Free running Ring oscillator can work in stop mode
- Oscillator stop and wake-up functions
- Programmable frequency divider for the CPU clock (f<sub>xx</sub> divided by 1, 2, 8 or 16)
- System clock control register, CLKCON
- Oscillator control register, OSCCON and STOP control register, STPCON
- Ring oscillator control register, ROSCCON

[Figure 7-1](#) illustrates the main oscillator circuit (RC Oscillator with Internal Capacitor).

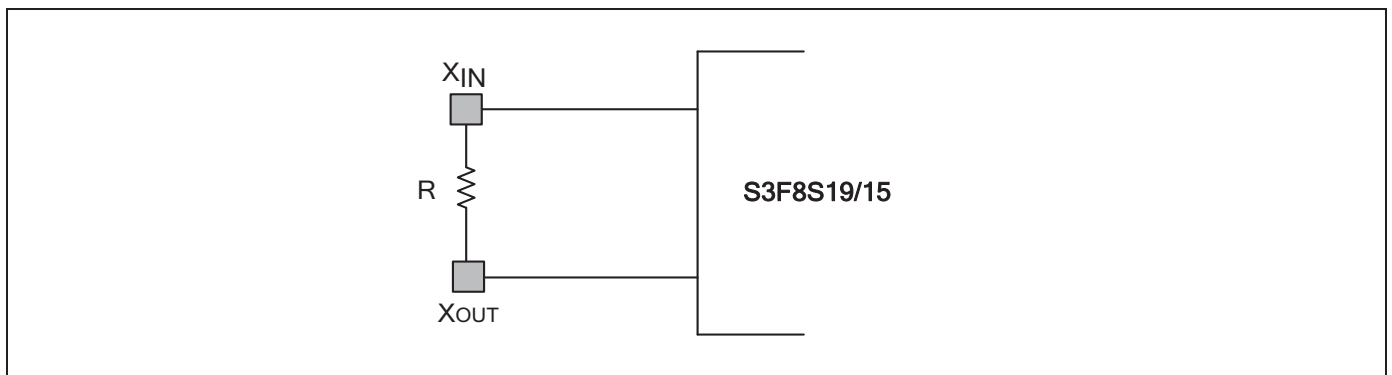


Figure 7-1 Main Oscillator Circuit (RC Oscillator with Internal Capacitor)

Figure 7-2 illustrates the main oscillator circuit (Crystal/Ceramic Oscillator).

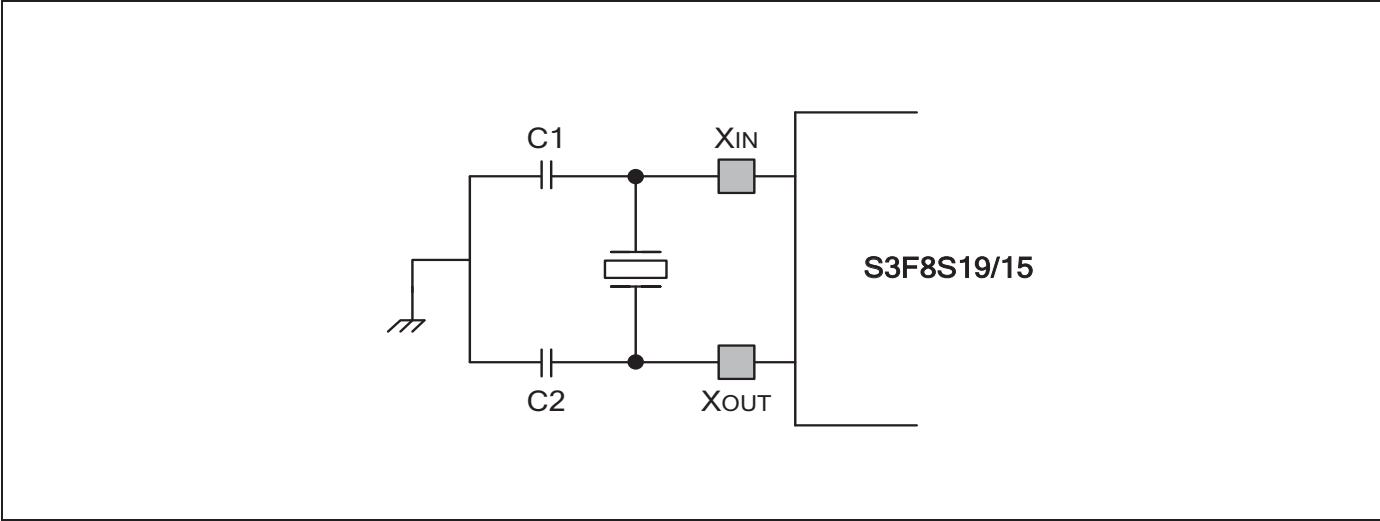


Figure 7-2 Main Oscillator Circuit (Crystal/Ceramic Oscillator)

Figure 7-3 illustrates the sub-system oscillator circuit.

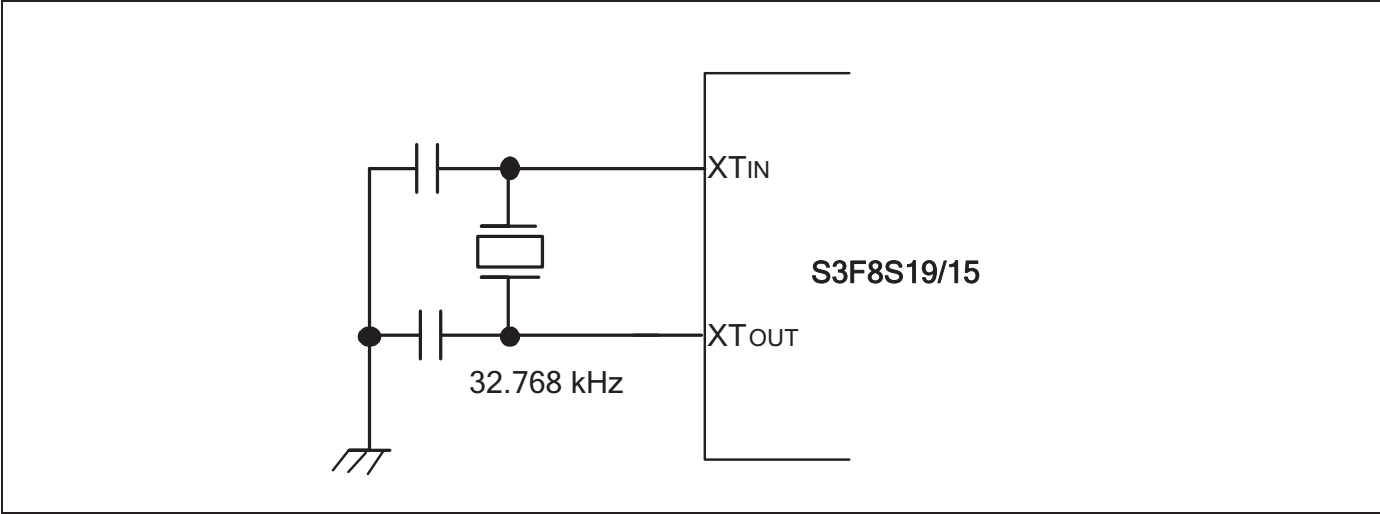


Figure 7-3 Sub-System Oscillator Circuit (Crystal Oscillator)

### 7.3 C2.Clock Status during Power-Down Modes

The two power-down modes, Stop mode and IDLE mode, affect clock oscillation as:

- In Stop mode, the main oscillator "freezes", halting the CPU and peripherals. The contents of the register file and current system register values are retained. A reset operation or an external interrupt with RC-delay noise filter releases stop mode and starts oscillator (for S3F8S19/F8S15, INTO–INT7).
- In Idle mode, the internal clock signal is gated off to the CPU, but not to interrupt control and the timer. The current CPU status is preserved, including stack pointer, program counter, and flags. Data in the register file is retained. Idle mode is released by a reset or by an interrupt (external or internally-generated).

### 7.4 System Clock Control Register (CLKCON)

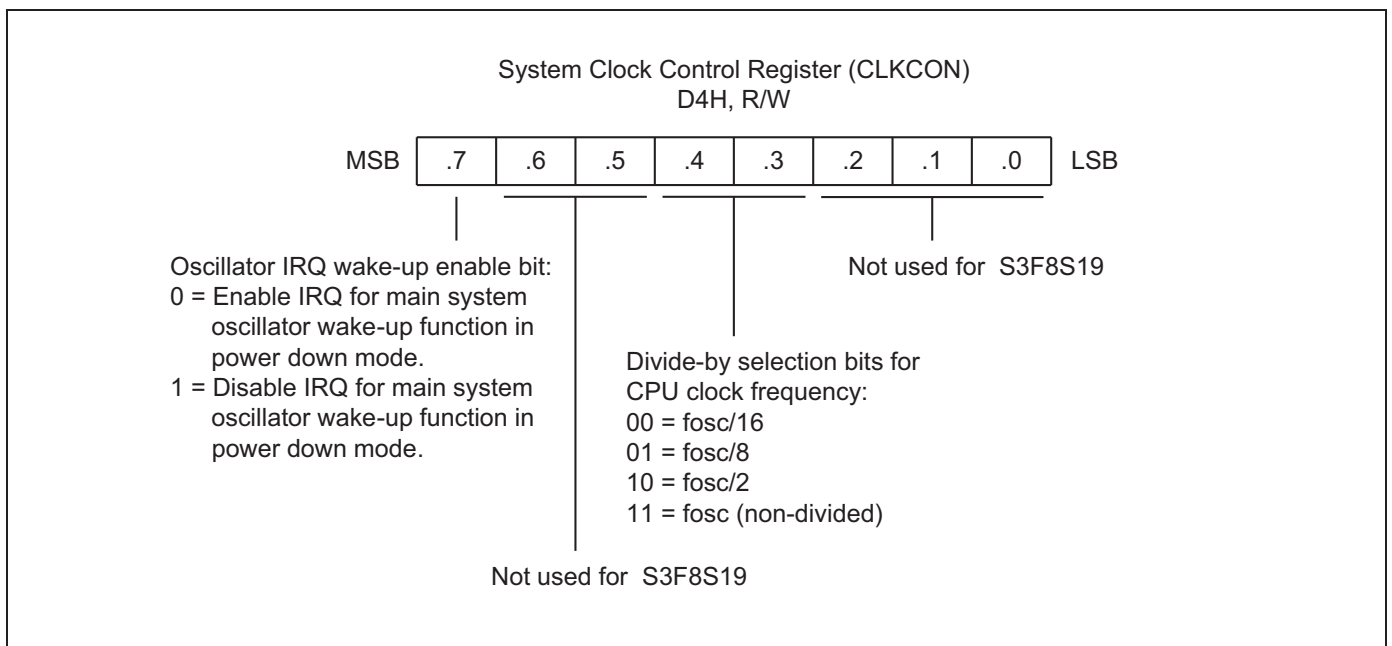
The system clock control register, CLKCON, is located in location D4H. It is Read/Write addressable and its functions are:

- Oscillator Interrupt request (IRQ) wake-up function enable/disable (CLKCON.7)
- Oscillator frequency divide-by value: non-divided, 2, 8 or 16 (CLKCON.4 and CLKCON.3)

The CLKCON register controls whether or not an external interrupt can be used to trigger a Stop mode release (this is called the "IRQ wake-up" function). The IRQ wake-up enable bit is CLKCON.7.

After a reset, the external interrupt oscillator wake-up function is enabled, and the  $f_{OSC}/16$  (the slowest clock speed) is selected as the CPU clock. If required, you can then increase the CPU clock speed to  $f_{OSC}$ ,  $f_{OSC}/2$  or  $f_{OSC}/8$ .

[Figure 7-4](#) illustrates the system clock control register.



**Figure 7-4 System Clock Control Register (CLKCON)**

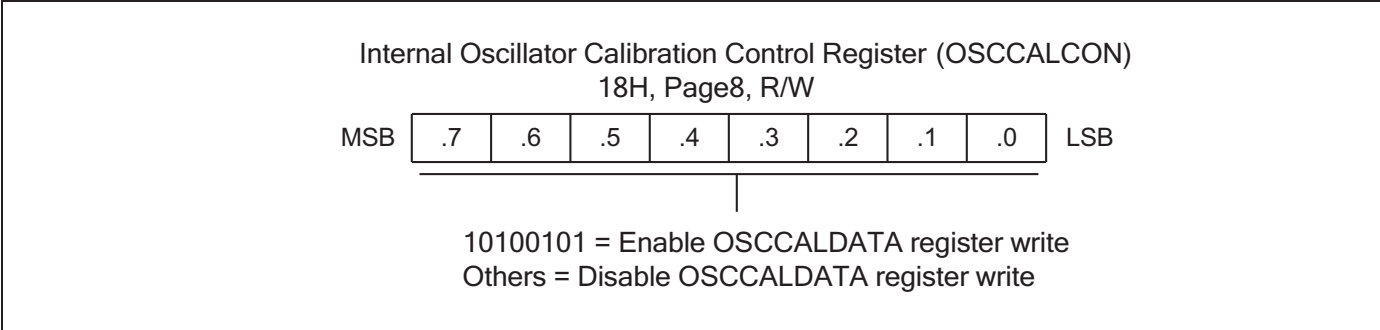
### 7.5 Internal Oscillator Calibration Control Register (OSCCALCON)

The internal oscillator calibration control register, OSCCALCON, is located in location 18H, on page8. It is Read/Write addressable and its functions are:

- Enables/disables OSCCALDATA register written.

After a reset, the OSCCALDATA register written is disabled, because the value of OSCCALCON is "other values". If required, you can write the OSCCALDATA register by setting the value of OSCCALCON to "10100101B".

*Figure 7-5* illustrates the internal oscillator calibration control register.



**Figure 7-5 Internal Oscillator Calibration Control Register (OSCCALCON)**



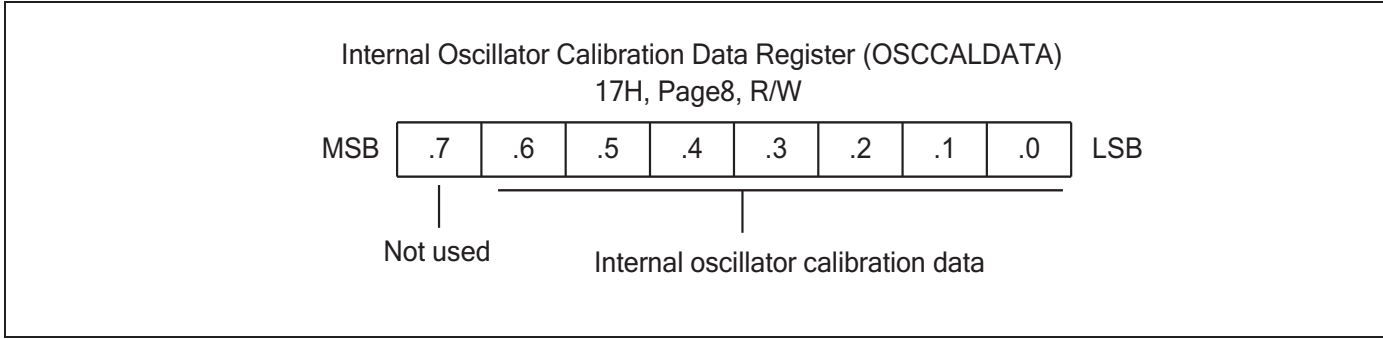
**7.6 Internal Oscillator Calibration Data Register (OSCCALDATA)**

The internal oscillator calibration data register, OSCCALDATA, is located in location 17H, on page8. It is Read/Write addressable and its functions are:

- Calibrate the internal oscillator

After a reset, a factory calibrated value is loaded to OSCCALDATA register. This value is factory calibrated at VDD = 5 V, 25oC. If used under different condition, you can calibrate the internal oscillator by writing different values to OSCCALDATA register. Setting the OSCCALDATA register to a lower value (minimum 0x00), results a higher frequency. While setting the OSCCALDATA register to a higher value (maximum 0x7F), results a lower frequency. Note that, before writing the OSCCALDATA register, the OSCCALCON register should be set to "10100101" to enable OSCCALDATA register data written.

[Figure 7-6](#) illustrates the internal oscillator calibration data register.



**Figure 7-6 Internal Oscillator Calibration Data Register (OSCCALDATA)**

### 7.7 Oscillator Control Register (OSCCON)

The oscillator control register, OSCCON, is located in set 1, bank 0, at address FBH.

It is Read/Write addressable and its functions are:

- System clock selection
- Main oscillator control
- Sub oscillator control

OSCCON.0 register settings selects Main clock or Sub clock as system clock.

After a reset, Main clock is selected for system clock because the reset value of OSCCON.0 is "0".

The main oscillator can be stopped or run by setting OSCCON.3.

The sub oscillator can be stopped or run by setting OSCCON.2.

[Figure 7-7](#) illustrates the oscillator control register.

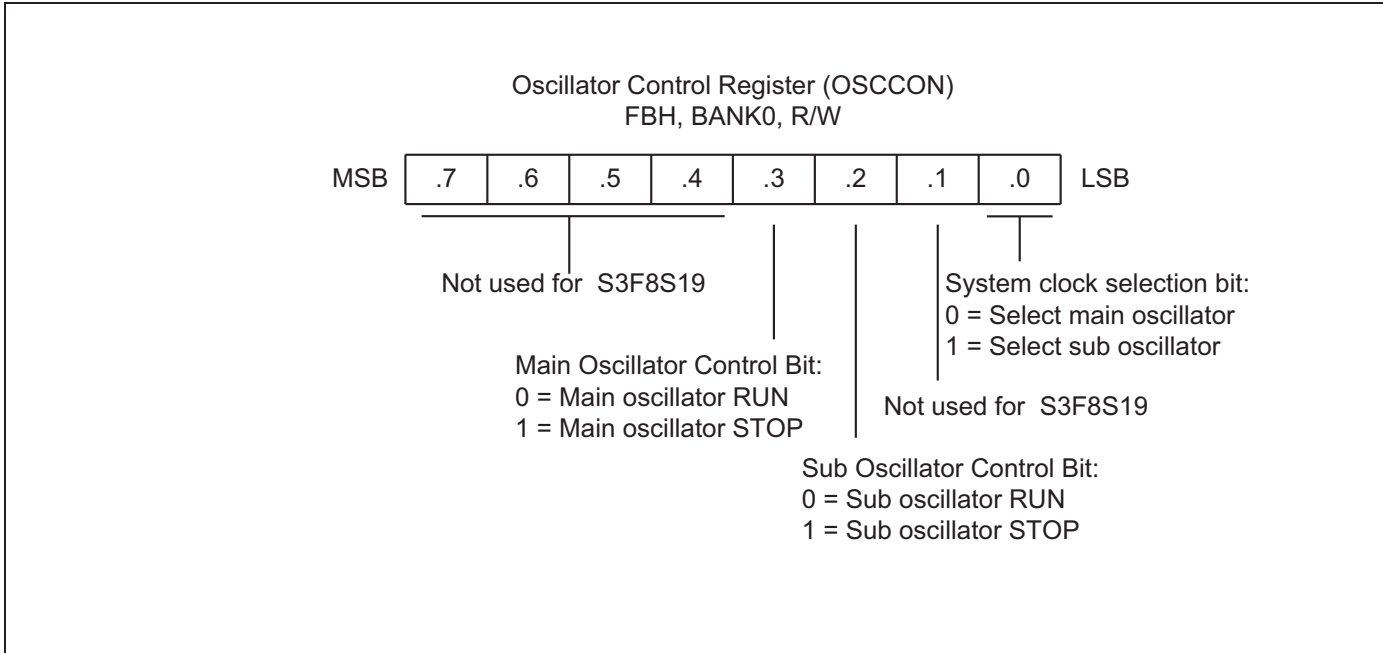


Figure 7-7 Oscillator Control Register (OSCCON)

## 7.8 Switching the CPU Clock

Data loading in the oscillator control register, OSCCON, determines whether a main or a sub clock is selected as the CPU clock. It also determines how this frequency is to be divided by setting CLKCON. This makes it possible to switch dynamically between main and sub clocks and to modify operating frequencies.

OSCCON.0 selects the main clock (fx) or the sub clock (fxt) for the CPU clock. OSCCON .3 starts or stops main clock oscillation, and OSCCON.2 starts or stops sub clock oscillation. CLKCON.4– .3 controls the frequency divider circuit, and divides the selected fxx clock by 1, 2, 8 and 16.

For example, you are using the default CPU clock (normal operating mode and a main clock of fx/16) and you want to switch from the main clock (fx) to a sub clock (fxt) and to stop the main clock. To do this, you need to set CLKCON.4-.3 to "11", OSCCON.0 to "1" and OSCCON.3 to "1" simultaneously. This switches the clock from fx to fxt and stops main clock oscillation.

The following steps must be taken to switch from a sub clock to the main clock are:

- Set OSCCON.3 to "0" to enable main clock oscillation
- After a certain number of machine cycles have elapsed, select the main clock by setting OSCCON.0 to "0"

[Example 7-1](#) shows the switching of CPU clock.

### Example 7-1 Switching the CPU clock

```
1. This example shows how to change from the main clock to the sub clock:
MA2SUB      LD      OSCCON, #09H          ; Switches to the sub clock
                                           ; Stop the main clock oscillation
                                           RET
2. This example shows how to change from sub clock to main clock:
SUB2MA      AND     OSCCON, #07H          ; Start the main clock oscillation
           CALL    DLY16                 ; Delay 16 ms
           AND     OSCCON, #06H          ; Switch to the main clock
           RET
DLY16       SRP     #0C0H
           LD      R0, #20H
DEL         NOP
           DJNZ   R0, DEL
           RET
```

## 7.9 Ring Oscillator Control Register (ROSCCON)

The Ring oscillator control register, ROSCCON, is located in Bank 1, at address FFH. It is Read/Write addressable and its functions are:

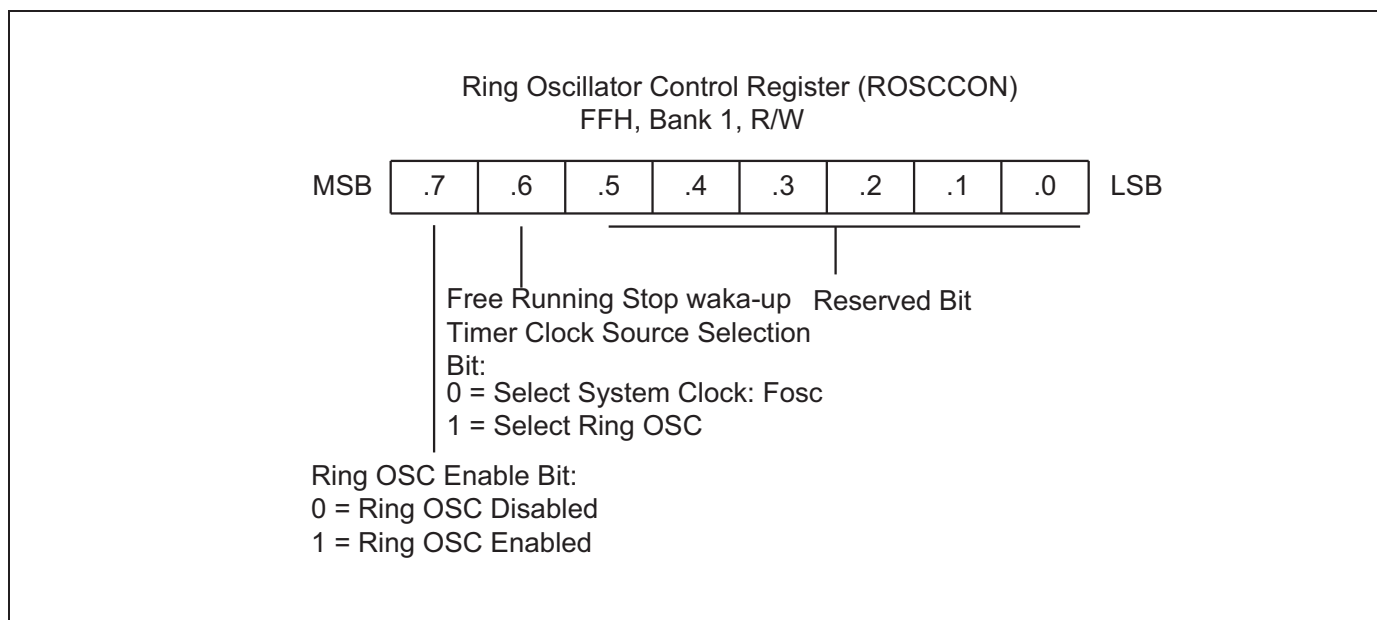
- Timer 1 clock source selection bit
- Ring oscillator enable bit

ROSCCON.6 register settings select system clock or Ring oscillator as Stop wake-up timer clock source.

After a reset, system clock is selected for Stop wake-up timer clock source because the reset value of ROSCCON.6 is "0".

The Ring oscillator can be stopped or run by setting ROSCCON.7.

[Figure 7-8](#) illustrates the ring oscillator control register.



**Figure 7-8 Ring Oscillator Control Register (ROSCCON)**



## 7.10 Stop Control Register (STPCON)

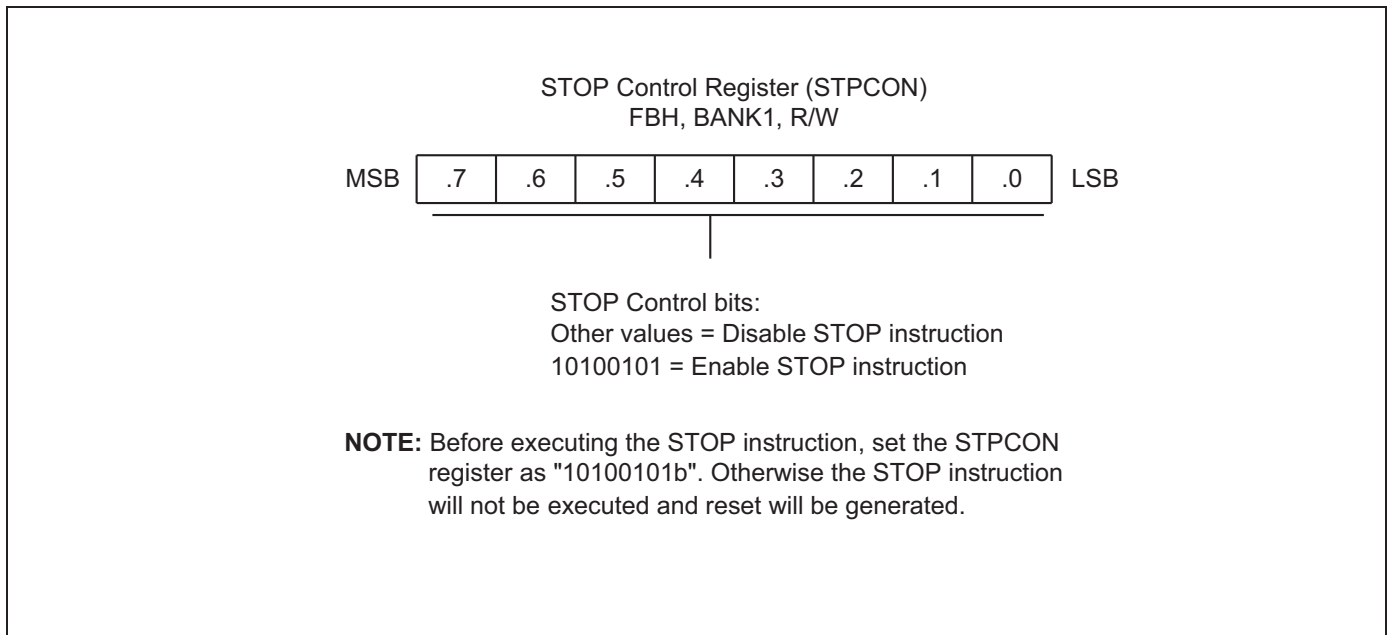
The STOP control register, STPCON, is located in the bank 1 of set1, address F8H. It is Read/Write addressable and its function are:

- Enable/Disable STOP instruction

After a reset, the STOP instruction is disabled, because the value of STPCON is "other values".

If required, you can use the STOP instruction by setting the value of STPCON to "10100101B".

[Figure 7-9](#) illustrates the STOP control register.



**Figure 7-9 STOP Control Register (STPCON)**

Figure 7-10 illustrates the system clock circuit diagram.

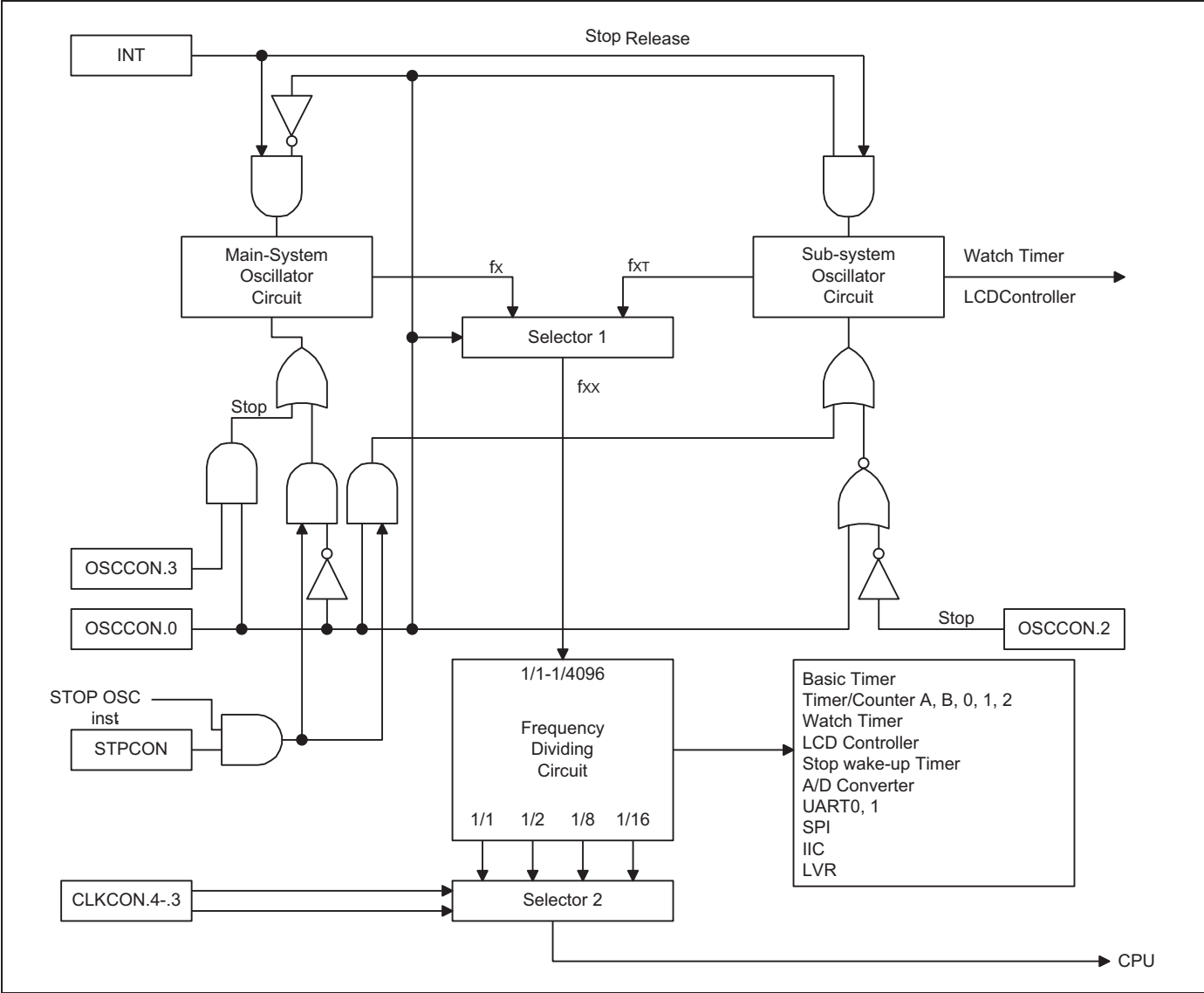


Figure 7-10 System Clock Circuit Diagram

# 8 RESET and Power-Down

## 8.1 Overview

By using smart option (3FH.7 in ROM), you can select internal RESET (Low Voltage Reset (LVR)) or external RESET.

You can reset the S3F8S19/F8S15 by using:

- External power-on-reset
- External nRESET input pin pulled low
- Digital watchdog peripheral timing out
- LVR

During an external power-on reset, the voltage at  $V_{DD}$  is High level and the nRESET pin is forced to Low level. The nRESET signal is an input through a Schmitt trigger circuit where it is then synchronized to CPU clock. This brings the S3F8S19/F8S15 into a known operating status. To ensure correct start-up, take care that you do not release nRESET signal before the  $V_{DD}$  level is sufficient to allow MCU operation at the chosen frequency.

The nRESET pin must be held as Low level for a minimum time interval after the power supply enters within tolerance to allow time for internal CPU clock oscillation to stabilize.

When a reset occurs during normal operation (with both  $V_{DD}$  and nRESET at High level), the signal at the nRESET pin is forced Low and the Reset operation starts. All system and peripheral control registers are then set to their default hardware Reset values (Refer to [Table 8-1](#) for more information).

The MCU provides a watchdog timer function to ensure graceful recovery from software malfunction. If watchdog timer is not refreshed before an end-of-counter condition (overflow) is reached, the internal reset will be activated.

The on-chip Low Voltage, Reset features static Reset when supply voltage is below a reference value (Type 1.9, 2.3, 3.0, 3.9 V). Owing to this feature, external reset circuit can be removed while keeping the application safety. As long as the supply voltage is below the reference value, there is an internal and static RESET. The MCU can start only when the supply voltage rises over the reference value.

When you calculate power consumption, ensure that a static current of LVR circuit should be added a CPU operating current in any operating modes such as Stop, Idle, and normal RUN mode.

Figure 8-1 illustrates the low voltage reset circuit.

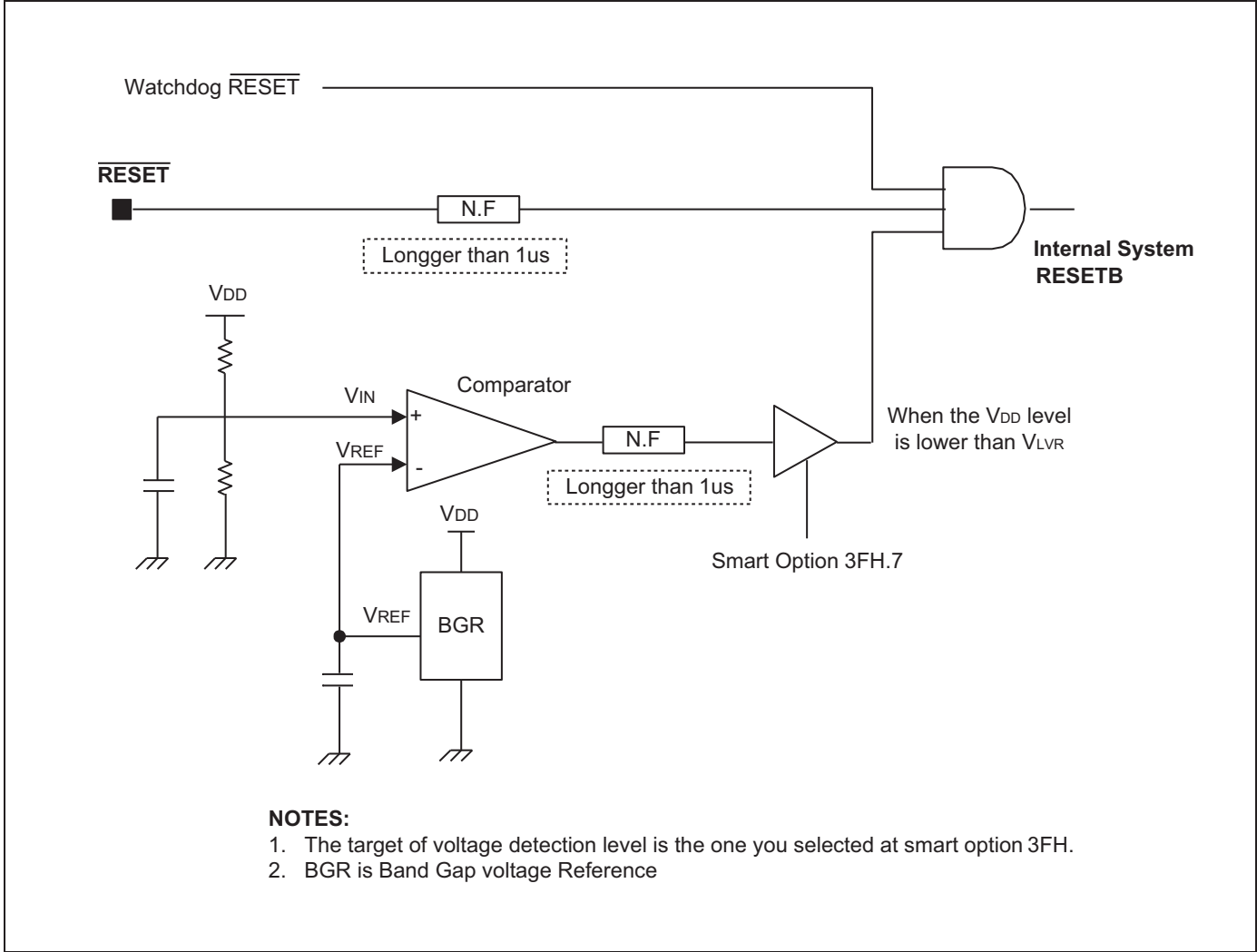


Figure 8-1 Low Voltage Reset Circuit

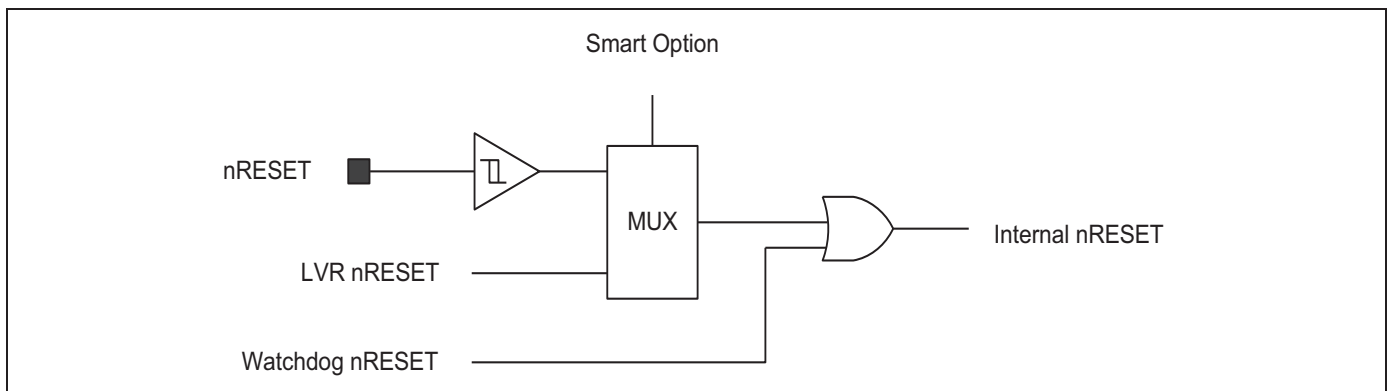
**NOTE:** To program the duration of the oscillation stabilization interval, you should make the appropriate settings to the basic timer control register, BTCON, before entering Stop mode. Also, if you do not want to use the basic timer watchdog function, which causes a system reset if a basic timer counter overflow occurs, you can disable it by writing "1010B" to the upper nibble of BTCON.

### 8.1.1 MCU Initialization Sequence

The sequences of events that occur during a Reset operation are:

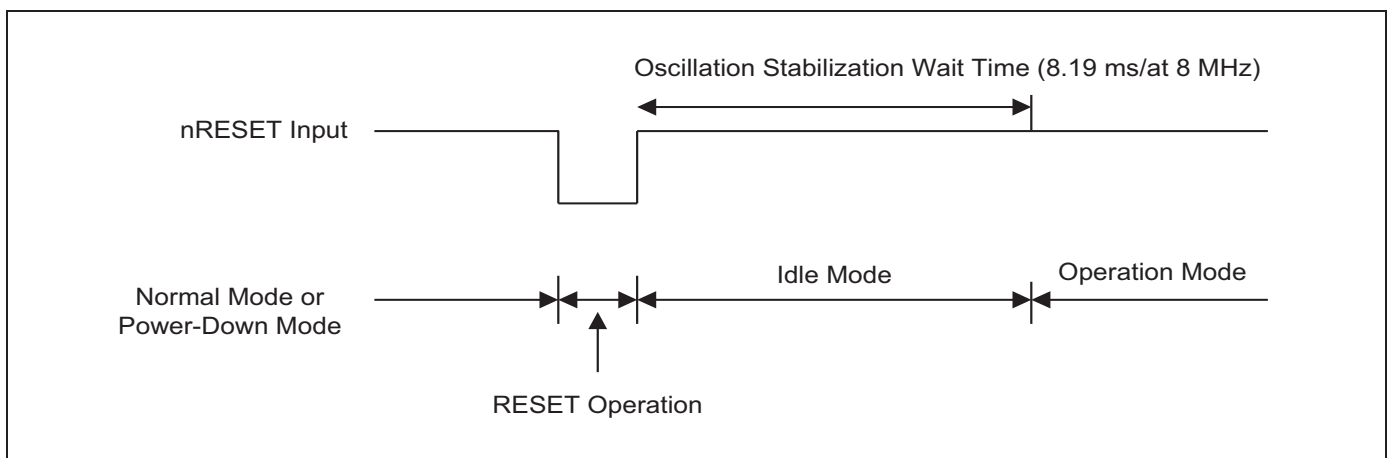
- All interrupts are disabled.
- The watchdog function (basic timer) is enabled.
- Ports 0–4 are set to input mode
- Peripheral control and data registers reset their initial values (Refer [Table 8-1](#) for more information).
- The program counter is loaded with the ROM reset address, 0100H or other values set by smart option.
- When the programmed oscillation stabilization time interval elapses, the address stored in the first and second bytes of RESET address in ROM is fetched and executed.

[Figure 8-2](#) illustrates the block diagram of reset.



**Figure 8-2 Reset Block Diagram**

[Figure 8-3](#) illustrates the timing for S3F8S19/F8S15 after reset.



**Figure 8-3 Timing for S3F8S19/F8S15 After RESET**

## 8.2 Power-Down Modes

This section includes:

- Stop Mode
- Using RESET to release Stop mode
- Using an external interrupt to release stop mode

### 8.2.1 Stop Mode

Stop mode is invoked by the instruction STOP (opcode 7FH). In Stop mode, the operation of the CPU and all peripherals is halted. That is, the on-chip main oscillator stops and the supply current is reduced to less than 2  $\mu$ A when LVR (Low Voltage Reset) is enabled. All system functions are halted when the clock "freezes", but data stored in the internal register file is retained. Stop mode can be released by using one of these methods:

- nRESET signal
- External interrupt

**NOTE:** Before executing the STOP instruction, STPCON register must be set to "10100101B".

### 8.2.2 Using RESET to Release Stop Mode

Stop mode is released when the nRESET signal is released and returns to High level. All system and peripheral control registers are then reset to their default values and the contents of all data registers are retained. A Reset operation automatically selects a slow clock ( $f_x/16$ ) because CLKCON.3 and CLKCON.4 are cleared to "00B". After the oscillation stabilization interval elapses, the CPU executes the system initialization routine by fetching the 16-bit address stored in the first and second bytes of RESET address (configured by smart option) in ROM.

### 8.2.3 Using an External Interrupt to Release Stop Mode

External interrupts with an RC-delay noise filter circuit can be used to release Stop mode (Clock-related external interrupts cannot be used). External interrupts INT0–INT7 in the S3F8S19/F8S15 interrupt structure meet this criterion.

Note that when Stop mode is released by an external interrupt, values in system and peripheral control registers does not change. When you use an interrupt to release Stop mode, the CLKCON.3 and CLKCON.4 register values remain do no change and the currently selected clock value is used. Thus you can also program the duration of the oscillation stabilization interval by putting the appropriate value to BTCON register before entering Stop mode.

The external interrupt is serviced when the Stop mode release occurs. After an Interrupt Return (IRET) from the service routine, the instruction immediately following the one that initiated Stop mode is executed.

### 8.3 IDLE Mode

Idle mode is invoked by the instruction IDLE (opcode 6FH). In Idle mode, CPU operations are halted while select peripherals remain active. During Idle mode, the internal clock signal is gated off to the CPU, but not to interrupt logic and timer/counters. Port pins retain the mode (input or output) they had at the time IDLE mode was entered.

There are two methods to release idle mode:

1. Execute a Reset. All system and peripheral control registers are reset to their default values and the contents of all data registers are retained. The Reset automatically selects a slow clock ( $f_{xx}/16$ ) because CLKCON.3 and CLKCON.4 are cleared to "00B". If interrupts are masked, a Reset is the only way to release idle mode.
2. Activate any enabled interrupt, causing idle mode to be released. When you use an interrupt to release idle mode, the CLKCON.3 and CLKCON.4 register values remain do not change, and the currently selected clock value is used. The interrupt is then serviced. After an IRET from the service routine, the instruction immediately following the one that initiated idle mode is executed.

**NOTE:**

1. Only external interrupts that are not clock-related can be used to release stop mode. However, to release Idle mode, any type of interrupt (that is, internal or external) can be used.
2. Before you enter the STOP or IDLE mode, ADC must be disabled. Otherwise, STOP or IDLE current will be increased significantly.

## 8.4 Hardware Reset Values

The reset values for CPU and system registers, peripheral control registers, and peripheral data registers following a reset operation.

The following notation is used to represent reset values:

- A "1" or a "0" show the reset bit value as logic one or logic zero, respectively.
- An "x" means that the bit value is undefined after a reset.
- A dash ("-") means that the bit is either not used or not mapped, but read 0 is the bit value.

[Table 8-1](#) lists the S3F8S19/F8S15 set1 register values after RESET.

**Table 8-1 S3F8S19/F8S15 Set1 Register Values after RESET**

| Register Name                           | Mnemonic | Address |     | R/W | nRESET Value(bit) |   |   |   |   |   |   |   |   |
|---|----------|---------|-----|-----|-------------------|---|---|---|---|---|---|---|---|
|   |          | Decimal | Hex |     | 7                 | 6 | 5 | 4 | 3 | 2 | 1 | 0 |   |
| A/D Converter Data Register (High Byte) | ADDATAH  | 208     | D0H | R   | x                 | x | x | x | x | x | x | x | x |
| A/D Converter Data Register (Low Byte)  | ADDATAH  | 209     | D1H | R   | -                 | - | - | - | - | - | - | x | x |
| A/D Converter Control Register          | ADCON    | 210     | D2H | R/W | 0                 | 0 | 0 | 0 | 0 | 0 | 0 | 0 | 0 |
| Basic Timer Control Register            | BTCON    | 211     | D3H | R/W | 0                 | 0 | 0 | 0 | 0 | 0 | 0 | 0 | 0 |
| System Clock control Register           | CLKCON   | 212     | D4H | R/W | 0                 | - | - | 0 | 0 | - | - | - | - |
| System Flags Register                   | FLAGS    | 213     | D5H | R/W | x                 | x | x | x | x | x | 0 | 0 | 0 |
| Register Pointer 0                      | RP0      | 214     | D6H | R/W | 1                 | 1 | 0 | 0 | 0 | - | - | - | - |
| Register Pointer 1                      | RP1      | 215     | D7H | R/W | 1                 | 1 | 0 | 0 | 1 | - | - | - | - |
| Stack Pointer (high byte)               | SPH      | 216     | D8H | R/W | x                 | x | x | x | x | x | x | x | x |
| Stack Pointer (low byte)                | SPL      | 217     | D9H | R/W | x                 | x | x | x | x | x | x | x | x |
| Instruction Pointer (High Byte)         | IPH      | 218     | DAH | R/W | x                 | x | x | x | x | x | x | x | x |
| Instruction Pointer (Low Byte)          | IPL      | 219     | DBH | R/W | x                 | x | x | x | x | x | x | x | x |
| Interrupt Request Register              | IRQ      | 220     | DCH | R   | 0                 | 0 | 0 | 0 | 0 | 0 | 0 | 0 | 0 |
| Interrupt Mask Register                 | IMR      | 221     | DDH | R/W | x                 | x | x | x | x | x | x | x | x |
| System Mode Register                    | SYM      | 222     | DEH | R/W | -                 | - | - | x | x | x | 0 | 0 | 0 |
| Register Page Pointer                   | PP       | 223     | DFH | R/W | 0                 | 0 | 0 | 0 | 0 | 0 | 0 | 0 | 0 |

**NOTE:** -: Not mapped or not used, x: Does not define.



Table 8-2 lists the value of system and peripheral control registers set1 bank 0.

**Table 8-2 System and Peripheral Control Registers Set1 Bank 0**

| Register Name                             | Mnemonic | Address |     | R/W | nRESET Value (bit) |   |   |   |   |   |   |   |   |
|---|----------|---------|-----|-----|--------------------|---|---|---|---|---|---|---|---|
|   |          | Decimal | Hex |     | 7                  | 6 | 5 | 4 | 3 | 2 | 1 | 0 |   |
| Timer A Counter Register                  | TACNT    | 224     | E0H | R   | 0                  | 0 | 0 | 0 | 0 | 0 | 0 | 0 | 0 |
| Timer A Data Register                     | TADATA   | 225     | E1H | R/W | 1                  | 1 | 1 | 1 | 1 | 1 | 1 | 1 | 1 |
| Timer A Control Register                  | TACON    | 226     | E2H | R/W | 0                  | 0 | 0 | 0 | 0 | 0 | 0 | 0 | 0 |
| Timer A Pre-scalar                        | TAPS     | 227     | E3H | R/W | 0                  | – | – | – | 0 | 0 | 0 | 0 | 0 |
| <b>Location E4H to E7H are Not Mapped</b> |          |         |     |     |                    |   |   |   |   |   |   |   |   |
| Timer 0 Counter Register (High Byte)      | T0CNTH   | 232     | E8H | R   | 0                  | 0 | 0 | 0 | 0 | 0 | 0 | 0 | 0 |
| Timer 0 Counter Register (Low Byte)       | T0CNTL   | 233     | E9H | R   | 0                  | 0 | 0 | 0 | 0 | 0 | 0 | 0 | 0 |
| Timer 0 Data Register (High Byte)         | T0DATAH  | 234     | EAH | R/W | 1                  | 1 | 1 | 1 | 1 | 1 | 1 | 1 | 1 |
| Timer 0 Data Register (Low Byte)          | T0DATAL  | 235     | EBH | R/W | 1                  | 1 | 1 | 1 | 1 | 1 | 1 | 1 | 1 |
| Timer 0 Control Register                  | T0CON    | 236     | ECH | R/W | 0                  | 0 | 0 | 0 | 0 | 0 | 0 | 0 | 0 |
| Timer 0 Pre-scalar                        | T0PS     | 237     | EDH | R/W | –                  | – | – | – | 0 | 0 | 0 | 0 | 0 |
| Timer 1 Counter Register (High Byte)      | T1CNTH   | 238     | EEH | R   | 0                  | 0 | 0 | 0 | 0 | 0 | 0 | 0 | 0 |
| Timer 1 Counter Register (Low Byte)       | T1CNTL   | 239     | EFH | R   | 0                  | 0 | 0 | 0 | 0 | 0 | 0 | 0 | 0 |
| Timer 1 Data Register (High Byte)         | T1DATAH  | 240     | F0H | R/W | 1                  | 1 | 1 | 1 | 1 | 1 | 1 | 1 | 1 |
| Timer 1 Data Register (Low Byte)          | T1DATAL  | 241     | F1H | R/W | 1                  | 1 | 1 | 1 | 1 | 1 | 1 | 1 | 1 |
| Timer 1 Control Register                  | T1CON    | 242     | F2H | R/W | 0                  | 0 | 0 | 0 | 0 | 0 | 0 | 0 | 0 |
| Timer 1 Pre-scalar                        | T1PS     | 243     | F3H | R/W | 0                  | – | – | – | 0 | 0 | 0 | 0 | 0 |
| Timer 2 Counter Register (High Byte)      | T2CNTH   | 244     | F4H | R   | 0                  | 0 | 0 | 0 | 0 | 0 | 0 | 0 | 0 |
| Timer 2 Counter Register (Low Byte)       | T2CNTL   | 245     | F5H | R   | 0                  | 0 | 0 | 0 | 0 | 0 | 0 | 0 | 0 |
| Timer 2 Data Register (High Byte)         | T2DATAH  | 246     | F6H | R/W | 1                  | 1 | 1 | 1 | 1 | 1 | 1 | 1 | 1 |
| Timer 2 Data Register (Low Byte)          | T2DATAL  | 247     | F7H | R/W | 1                  | 1 | 1 | 1 | 1 | 1 | 1 | 1 | 1 |
| Timer 2 Control Register                  | T2CON    | 248     | F8H | R/W | 0                  | 0 | 0 | 0 | 0 | 0 | 0 | 0 | 0 |
| Timer 2 Pre-scalar                        | T2PS     | 249     | F9H | R/W | 0                  | – | – | – | 0 | 0 | 0 | 0 | 0 |
| Watch Timer Control Register              | WTCON    | 250     | FAH | R/W | 0                  | 0 | 0 | 0 | 0 | 0 | 0 | 0 | 0 |
| Oscillator Control Register               | OSCCON   | 251     | FBH | R/W | –                  | – | – | – | 0 | 0 | – | 0 | 0 |
| <b>Location FCH is Not Mapped</b>         |          |         |     |     |                    |   |   |   |   |   |   |   |   |
| Basic Timer Counter                       | BTCNT    | 253     | FDH | R   | 0                  | 0 | 0 | 0 | 0 | 0 | 0 | 0 | 0 |
| <b>Location FEH is Not Mapped</b>         |          |         |     |     |                    |   |   |   |   |   |   |   |   |
| Interrupt Priority Register               | IPR      | 255     | FFH | R/W | x                  | x | x | x | x | x | x | x | x |

**NOTE:** –: Not mapped or not used, x: Undefined

Table 8-3 lists the value of system and peripheral control registers set1 bank 1.

**Table 8-3 System and Peripheral Control Registers Set1 Bank 1**

| Register Name                             | Mnemonic | Address |     | R/W | nRESET Value (bit)          |   |   |   |   |   |   |   |   |
|---|----------|---------|-----|-----|-----------------------------|---|---|---|---|---|---|---|---|
|   |          | Decimal | Hex |     | 7                           | 6 | 5 | 4 | 3 | 2 | 1 | 0 |   |
| Port 0 Control Register (High Byte)       | P0CONH   | 224     | E0H | R/W | 0                           | 0 | 0 | 0 | 0 | 0 | 0 | 0 | 0 |
| Port 0 Control Register (Low Byte)        | P0CONL   | 225     | E1H | R/W | 0                           | 0 | 0 | 0 | 0 | 0 | 0 | 0 | 0 |
| Port 0 Pull-up Resistor Enable Register   | P0PUR    | 226     | E2H | R/W | 0                           | 0 | 0 | 0 | 0 | 0 | 0 | 0 | 0 |
| Port 0 Interrupt Control Register         | P0INT    | 227     | E3H | R/W | 0                           | 0 | 0 | 0 | 0 | 0 | 0 | 0 | 0 |
| Port 1 Control Register (High Byte)       | P1CONH   | 228     | E4H | R/W | 0                           | 0 | 0 | 0 | 0 | 0 | 0 | 0 | 0 |
| Port 1 Control Register (Low Byte)        | P1CONL   | 229     | E5H | R/W | 0                           | 0 | 0 | 0 | 0 | 0 | 0 | 0 | 0 |
| Port 2 Control Register (High Byte)       | P2CONH   | 230     | E6H | R/W | 0                           | 0 | 0 | 0 | 0 | 0 | 0 | 0 | 0 |
| Port 2 Control Register (Low Byte)        | P2CONL   | 231     | E7H | R/W | 0                           | 0 | 0 | 0 | 0 | 0 | 0 | 0 | 0 |
| Port 3 Control Register (High Byte)       | P3CONH   | 232     | E8H | R/W | 0                           | 0 | 0 | 0 | 0 | 0 | 0 | 0 | 0 |
| Port 3 Control Register (Low Byte)        | P3CONL   | 233     | E9H | R/W | 0                           | 0 | 0 | 0 | 0 | 0 | 0 | 0 | 0 |
| Port 3 N-Channel Open-drain Mode Register | PNE3     | 234     | EAH | R/W | 0                           | 0 | 0 | 0 | 0 | 0 | 0 | 0 | 0 |
| Port 3 Interrupt Control Register         | P3INT    | 235     | EBH | R/W | 0                           | 0 | 0 | 0 | 0 | 0 | 0 | 0 | 0 |
| Port 3 Pull-up Resistor Enable Register   | P3PUR    | 236     | ECH | R/W | 0                           | 0 | 0 | 0 | 0 | 0 | 0 | 0 | 0 |
| Port 4 Pull-up Resistor Enable Register   | P4PUR    | 237     | EDH | R/W | 0                           | 0 | 0 | 0 | 0 | 0 | 0 | 0 | 0 |
| Port 4 Control Register (High Byte)       | P4CONH   | 238     | EEH | R/W | 0                           | 0 | 0 | 0 | 0 | 0 | 0 | 0 | 0 |
| Port 4 Control Register (Low Byte)        | P4CONL   | 239     | EFH | R/W | 0                           | 0 | 0 | 0 | 0 | 0 | 0 | 0 | 0 |
| Port 4 N-Channel Open-drain Mode Register | PNE4     | 240     | F0H | R/W | 0                           | 0 | 0 | 0 | 0 | 0 | 0 | 0 | 0 |
| Port 0 Data Register                      | P0       | 241     | F1H | R/W | 0                           | 0 | 0 | 0 | 0 | 0 | 0 | 0 | 0 |
| Port 1 Data Register                      | P1       | 242     | F2H | R/W | 0                           | 0 | 0 | 0 | 0 | 0 | 0 | 0 | 0 |
| Port 2 Data Register                      | P2       | 243     | F3H | R/W | 0                           | 0 | 0 | 0 | 0 | 0 | 0 | 0 | 0 |
| Port 3 Data Register                      | P3       | 244     | F4H | R/W | 0                           | 0 | 0 | 0 | 0 | 0 | 0 | 0 | 0 |
| Port 4 Data Register                      | P4       | 245     | F5H | R/W | 0                           | 0 | 0 | 0 | 0 | 0 | 0 | 0 | 0 |
| External Interrupt Pending Register       | PINTPND  | 246     | F6H | R/W | 0                           | 0 | 0 | 0 | 0 | 0 | 0 | 0 | 0 |
| SPI Control Register                      | SPICON   | 247     | F7H | R/W | 0                           | 0 | 0 | 0 | 0 | 0 | 0 | 0 | 0 |
| SPI Status Register                       | SPISTAT  | 248     | F8H | R/W | 0                           | 0 | 0 | – | – | – | – | 0 | 0 |
| SPI Data Register                         | SPIDATA  | 249     | F9H | R/W | 1                           | 1 | 1 | 1 | 1 | 1 | 1 | 1 | 1 |
| Reset ID                                  | RESETID  | 250     | FAH | R/W | Refer to detail description |   |   |   |   |   |   |   |   |
| STOP Control Register                     | STPCON   | 251     | FBH | R/W | 0                           | 0 | 0 | 0 | 0 | 0 | 0 | 0 | 0 |
| LCD Mode Register                         | LMOD     | 252     | FCH | R/W | –                           | – | – | – | – | 0 | 0 | 0 | 0 |
| LCD Control Register                      | LCON     | 253     | FDH | R/W | 0                           | 0 | 0 | 0 | 0 | 0 | 0 | 0 | 0 |

| Register Name             | Mnemonic | Address |     | R/W | nRESET Value (bit) |   |   |   |   |   |   |   |
|---------------------------|----------|---------|-----|-----|--------------------|---|---|---|---|---|---|---|
|                           |          | Decimal | Hex |     | 7                  | 6 | 5 | 4 | 3 | 2 | 1 | 0 |
| LVD Control Register      | LVDCON   | 254     | FEH | R/W | 1                  | – | 0 | 0 | 0 | – | 0 | 0 |
| Ring OSC Control Register | ROSCCON  | 255     | FFH | R/W | 0                  | 0 | 0 | 0 | 0 | 0 | 0 | 0 |

**NOTE:** –: Not mapped or not used, read "0"; x: Undefined

[Table 8-4](#) lists the values of system and peripheral control registers page 8.

**Table 8-4 System and Peripheral Control Registers Page 8**

| Register Name                                    | Mnemonic  | Address |     | R/W | nRESET Value (bit) |   |   |   |   |   |   |   |
|--|-----------|---------|-----|-----|--------------------|---|---|---|---|---|---|---|
|  |           | Decimal | Hex |     | 7                  | 6 | 5 | 4 | 3 | 2 | 1 | 0 |
| UART0 Control Register (High Byte)               | UART0CONH | 0       | 00H | R/W | 0                  | 0 | 0 | 0 | 0 | 0 | 0 | 0 |
| UART0 Control Register (Low Byte)                | UART0CONL | 1       | 01H | R/W | 0                  | 0 | 0 | 0 | 0 | 0 | 0 | 0 |
| UART0 Data Register                              | UDATA0    | 2       | 02H | R/W | x                  | x | x | x | x | x | x | x |
| UART0 Baud Rate Data Register                    | BRDATA0   | 3       | 03H | R/W | 1                  | 1 | 1 | 1 | 1 | 1 | 1 | 1 |
| UART1 Control Register (High Byte)               | UART1CONH | 4       | 04H | R/W | 0                  | 0 | 0 | 0 | 0 | 0 | 0 | 0 |
| UART1 Control Register (Low Byte)                | UART1CONL | 5       | 05H | R/W | 0                  | 0 | 0 | 0 | 0 | 0 | 0 | 0 |
| UART1 Data Register                              | UDATA1    | 6       | 06H | R/W | x                  | x | x | x | x | x | x | x |
| UART1 Baud Rate Data Register                    | BRDATA1   | 7       | 07H | R/W | 1                  | 1 | 1 | 1 | 1 | 1 | 1 | 1 |
| Flash Memory Sector Address Register (High Byte) | FMSECH    | 8       | 08H | R/W | 0                  | 0 | 0 | 0 | 0 | 0 | 0 | 0 |
| Flash Memory Sector Address Register (Low Byte)  | FMSECL    | 9       | 09H | R/W | 0                  | 0 | 0 | 0 | 0 | 0 | 0 | 0 |
| Flash Memory User Programming Enable Register    | FMUSR     | 10      | 0AH | R/W | 0                  | 0 | 0 | 0 | 0 | 0 | 0 | 0 |
| Flash Memory Control Register                    | FMCON     | 11      | 0BH | R/W | 0                  | 0 | 0 | 0 | 0 | – | – | 0 |
| IIC Control Register                             | ICCR      | 12      | 0CH | R/W | 0                  | 0 | 0 | 0 | 1 | 1 | 1 | 1 |
| IIC Status Register                              | ICSR      | 13      | 0DH | R/W | 0                  | 0 | 0 | 0 | 0 | 0 | 0 | 0 |
| IIC Data Shift Register                          | IDSR      | 14      | 0EH | R/W | x                  | x | x | x | x | x | x | x |
| IIC Address Register                             | IAR       | 15      | 0FH | R/W | x                  | x | x | x | x | x | x | x |
| Stop Wake-up Timer Control Register              | SWTCON    | 16      | 10H | R/W | 0                  | 0 | 0 | 0 | 0 | 0 | 0 | 0 |
| 16-bit Timer B control register                  | TBCON     | 17      | 11H | R/W | 0                  | 0 | 0 | 0 | 0 | 0 | 0 | 0 |
| Timer B Reference Data Register 0 (High Byte)    | TBDATA0H  | 18      | 12H | R/W | 1                  | 1 | 1 | 1 | 1 | 1 | 1 | 1 |
| Timer B Reference Data Register 0 (Low Byte)     | TBDATA0L  | 19      | 13H | R/W | 1                  | 1 | 1 | 1 | 1 | 1 | 1 | 1 |

| Register Name                                 | Mnemonic   | Address |     | R/W | nRESET Value (bit) |        |   |   |   |   |   |   |   |
|---|------------|---------|-----|-----|--------------------|--------|---|---|---|---|---|---|---|
|   |            | Decimal | Hex |     | 7                  | 6      | 5 | 4 | 3 | 2 | 1 | 0 |   |
| Timer B Reference Data Register 1 (High Byte) | TBDATA1H   | 20      | 14H | R/W | 1                  | 1      | 1 | 1 | 1 | 1 | 1 | 1 | 1 |
| Timer B Reference Data Register 1 (Low Byte)  | TBDATA1L   | 21      | 15H | R/W | 1                  | 1      | 1 | 1 | 1 | 1 | 1 | 1 | 1 |
| Timer B Trigger Control Register              | TBTRG      | 22      | 16H | R/W | 0                  | 0      | 0 | 0 | 0 | 0 | 0 | 0 | 0 |
| Internal OSC Calibration Data Register        | OSCCALDATA | 23      | 17H | R/W | –                  | (NOTE) |   |   |   |   |   |   |   |
| Internal OSC Calibration Control Register     | OSCCALCON  | 24      | 18H | R/W | 0                  | 0      | 0 | 0 | 0 | 0 | 0 | 0 | 0 |

**NOTE:** The reset value of OSCCALDATA register is factory-calibrated. Different chips may have different reset values.

# 9 Input/Output (I/O) Ports

## 9.1 Overview

The S3F8S19/F8S15 microcontroller has 5-bit-programmable I/O ports, P0-P4. This port provides a total of 40 I/O pins. Each port can be flexibly configured to meet application design requirements. The CPU accesses ports by directly writing or reading port registers. No special I/O instructions are required.

[Table 9-1](#) lists configuration overview of the S3F8S19/F8S15 I/O port functions.

**Table 9-1 S3F8S19/F8S15 Port Configuration Overview**

| Port | Configuration Options   |
|------|---|
| 0    | I/O port with bit-programmable pins.<br>Configurable to Schmitt trigger input or push-pull output mode. Pull-up resistors can be assigned by software. Pins can also be assigned individually as alternative function pins. |
| 1    | I/O port with bit-programmable pins.<br>Configurable to input or push-pull output mode. Pull-up resistors can be assigned by software. Pins can also be assigned individually as alternative function pins.                 |
| 2    | I/O port with bit-programmable pins.<br>Configurable to input mode, push-pull output mode. Pins can also be assigned individually as alternative function pins.   |
| 3    | I/O port with bit-programmable pins.<br>Configurable to Schmitt trigger input mode, push-pull output mode or open-drain output mode. Pins can also be assigned individually as alternative function pins.                   |
| 4    | I/O port with bit-programmable pins.<br>Configurable to input mode, push-pull output mode or open-drain output mode. Pins can also be assigned individually as alternative function pins.                                   |

## 9.2 Port Data Registers

[Table 9-2](#) provides an overview of the register locations of all five S3F8S19/F8S15 I/O port data registers.

Data registers for ports 0, 1, 2, 3 and 4 have the general format as illustrated in [Figure 9-1](#).

**Table 9-2 Port Data Register Summary**

| Register Name        | Mnemonic | Decimal | Hex | Location    | R/W |
|----------------------|----------|---------|-----|-------------|-----|
| Port 0 data register | P0       | 241     | F1H | Set1, Bank1 | R/W |
| Port 1 data register | P1       | 242     | F2H | Set1, Bank1 | R/W |
| Port 2 data register | P2       | 243     | F3H | Set1, Bank1 | R/W |
| Port 3 data register | P3       | 244     | F4H | Set1, Bank1 | R/W |
| Port 4 data register | P4       | 245     | F5H | Set1, Bank1 | R/W |

## 9.3 Port 0

Port 0 is an 8-bit I/O port that you can use in two ways:

- General-purpose I/O
- Alternative function

Port 0 is accessed directly by writing or reading the port 0 data register, P0 at location F1H, Set1 Bank1.

### 9.3.1 Port 0 Control Register (P0CONH, P0CONL)

Port 0 pins are configured individually by bit-pair settings in two control registers located at:

- P0CONH (high byte, E0H, Set1 Bank1)
- P0CONL (low byte, E1H, Set1 Bank1)

When you select output mode, a push-pull circuit is configured. The various selections that are available are:

- Schmitt trigger input mode.
- Output mode (Push-pull or Open-drain)
- Alternative function: External Interrupt – INT0, INT1, INT2, INT3
- Alternative function: BUZ output-BUZ
- Alternative function: ADC input-ADC0-ADC7

Figure 9-1 illustrates the port 0 control register high byte (P0CONH)

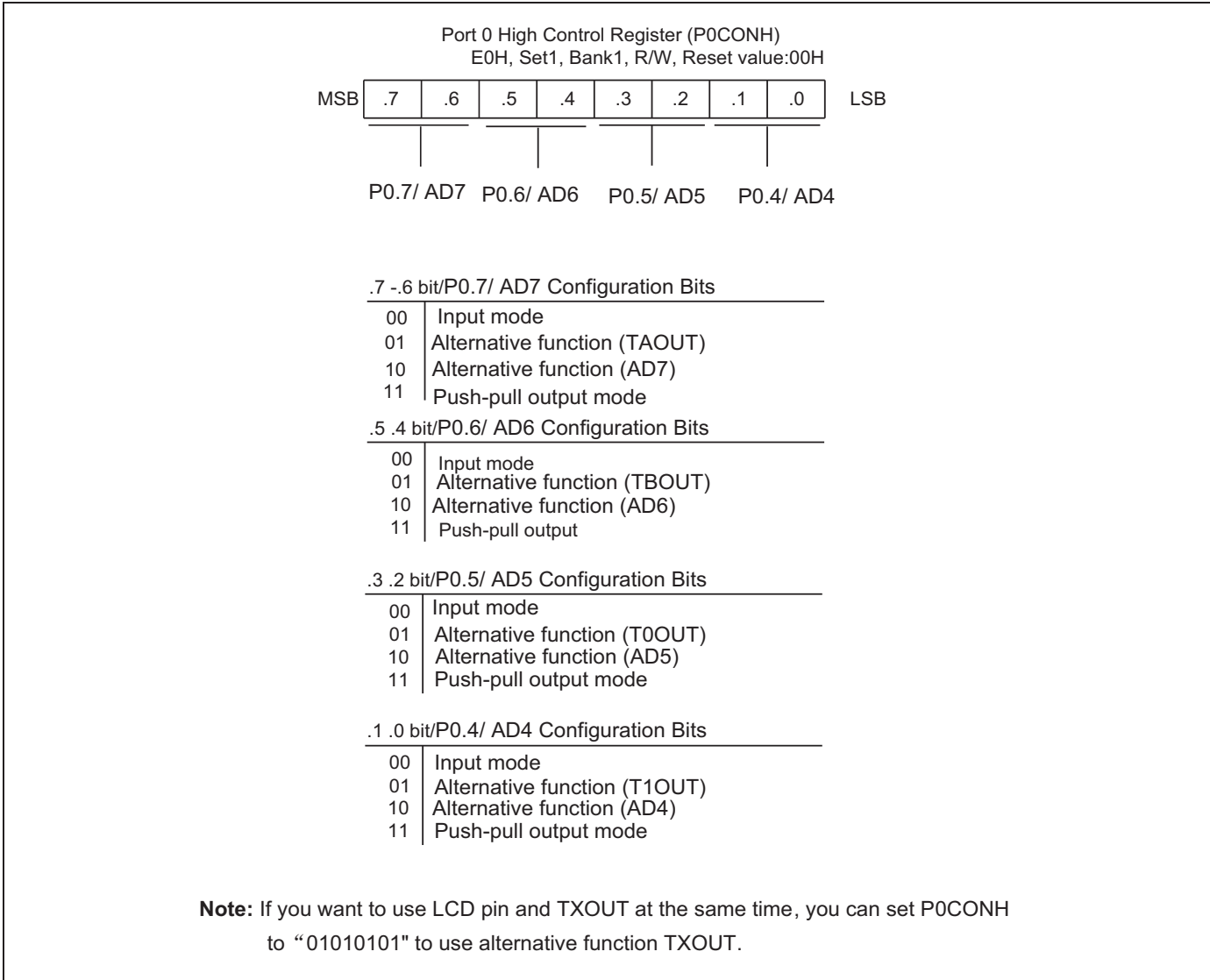
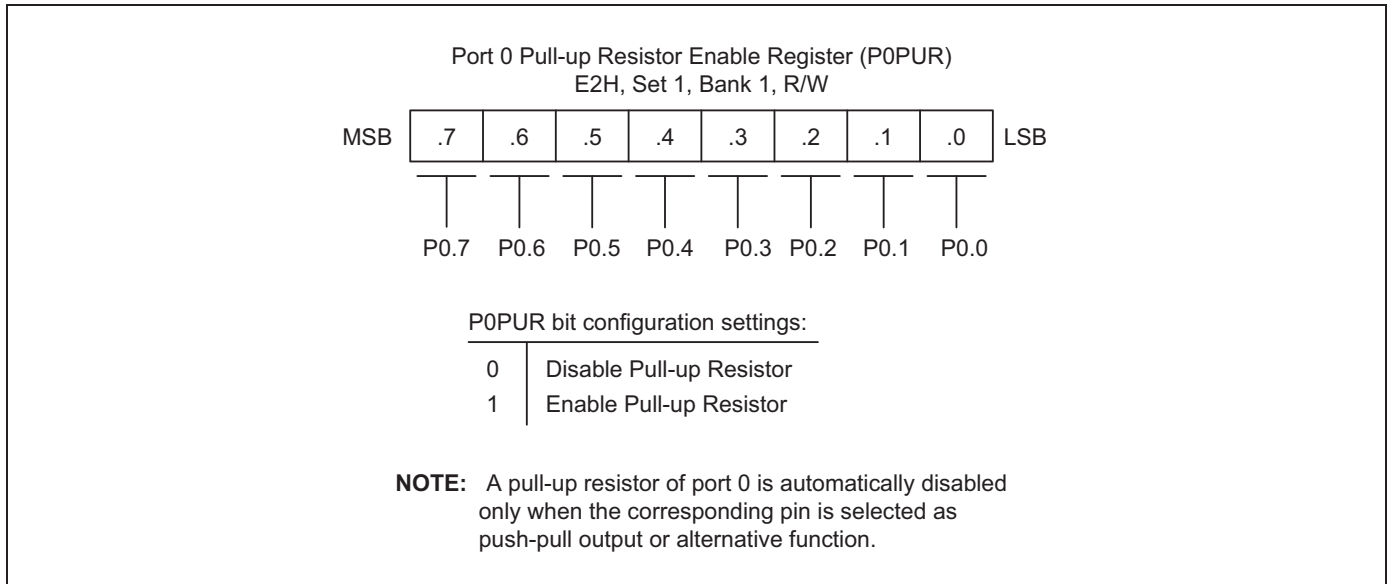


Figure 9-1 Port 0 Control Register High Byte (P0CONH)

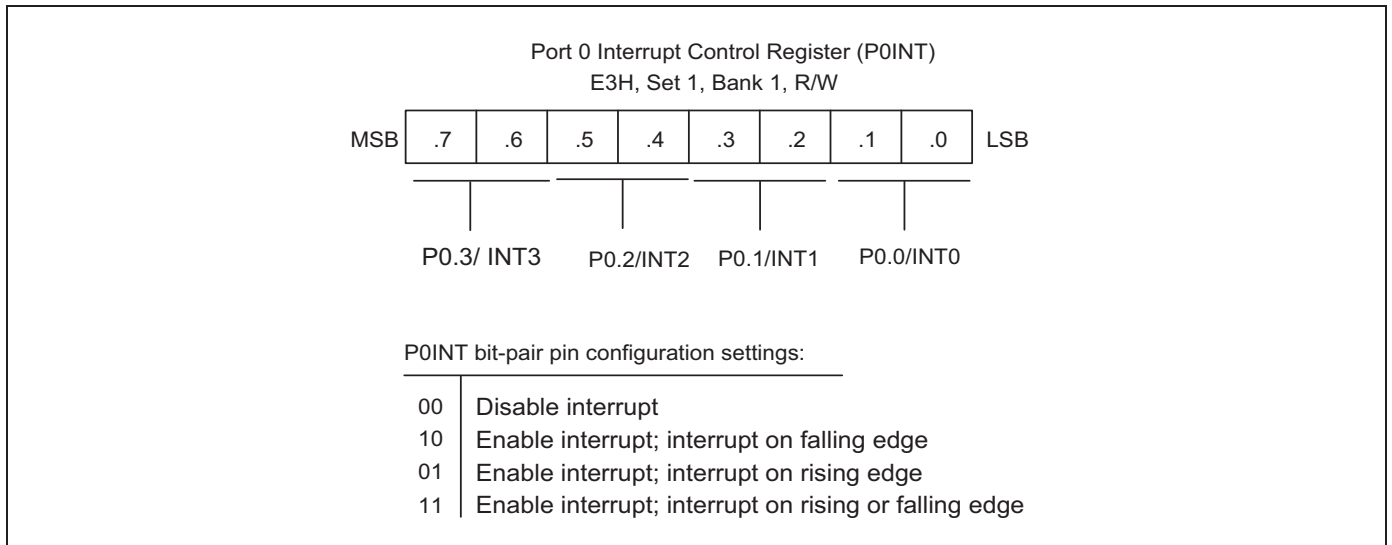


[Figure 9-2](#) illustrates the pull-up resistor enable register (P0PUR).



**Figure 9-2 Pull-Up Resistor Enable Register (P0PUR)**

[Figure 9-3](#) illustrates the Port 0 interrupt control register (P0INT).



**Figure 9-3 Port 0 Interrupt Control Register (P0INT)**

## 9.4 Port 1

Port 1 is an 8-bit I/O port with individually configurable pins. Port 1 pins are accessed directly by writing or reading the port 1 data register, P1 at location F2H in set 1, bank1. P1.0–P1.7 can serve as inputs (with or without pull-ups) and push-pull outputs or you can configure the alternative functions:

- CA, CB, VLC0 to VLC3

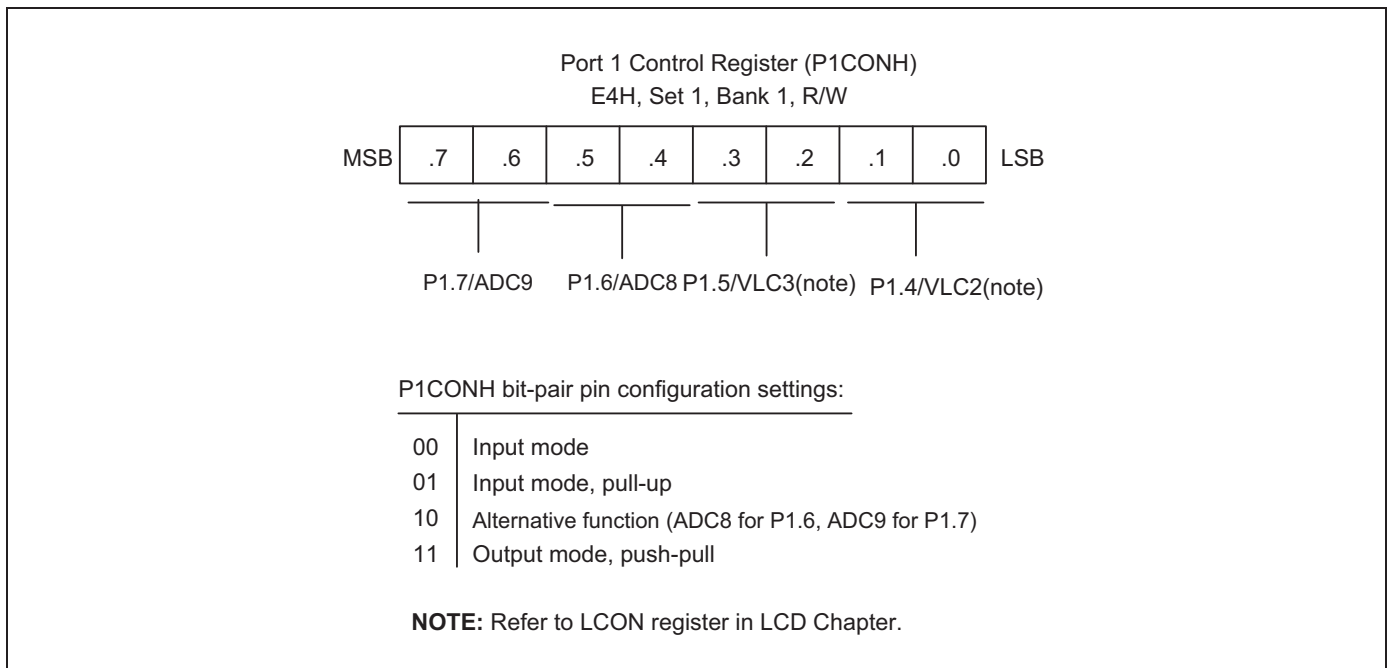
### 9.4.1 Port 1 Control Register High Byte

Port 1 has one 8-bit control register: P1CONH for P1.7–P1.4. A reset clears the P1CONH registers to "00H" by configuring all pins to input mode. You use control registers settings to:

- Select input or output mode
- Enable pull-up resistors
- Select push-pull mode
- Enable the alternative functions

While programming the port, remember that any alternative peripheral I/O function you configure using the port 1 control registers must also be enabled in the associated peripheral module.

[Figure 9-4](#) illustrates the Port 1 control register high byte.



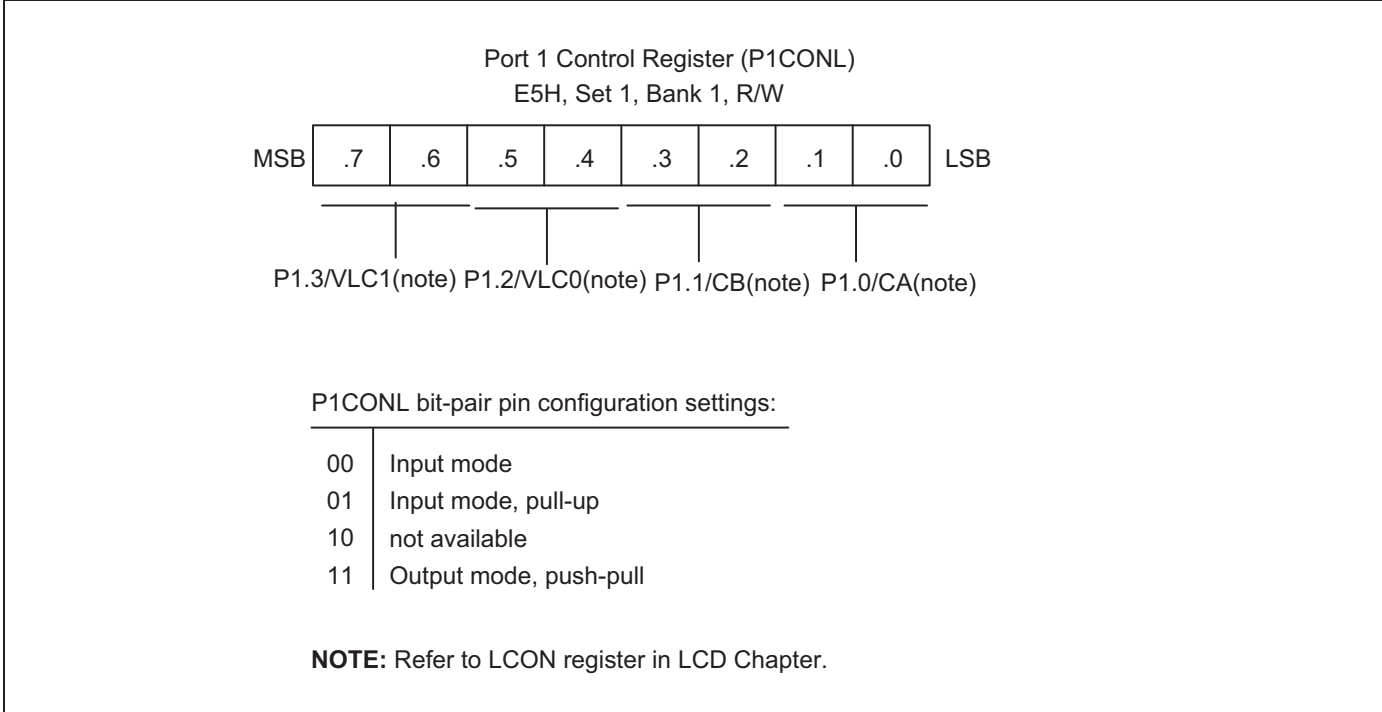
**Figure 9-4 Port 1 Control Register High Byte**

### 9.4.2 Port 1 Control Register Low Byte (P1CONL)

Port 1 has one 8-bit control register: P1CONL for P1.3–P1.0. A reset clears the P1CONL registers to "00H" by configuring all pins to input mode. You use control registers settings to select input or output mode, enable pull-up resistors, select push-pull mode and enable the alternative functions.

When programming the port, please remember that any alternative peripheral I/O function you configure using the port 1 control registers must also be enabled in the associated peripheral module.

[Figure 9-5](#) illustrates the port 1 control register low byte.



**Figure 9-5 Port 1 Control Register Low Byte**

## 9.5 Port 2

Port 2 is an 8-bit I/O port with individually configurable pins. Port 2 pins are accessed directly by writing or reading the port 2 data register, P2 at location F3H in set 1, bank 1. P2.0–P2.7 can serve as inputs (with or without pull-ups) and push-pull outputs or you can configure the alternative functions:

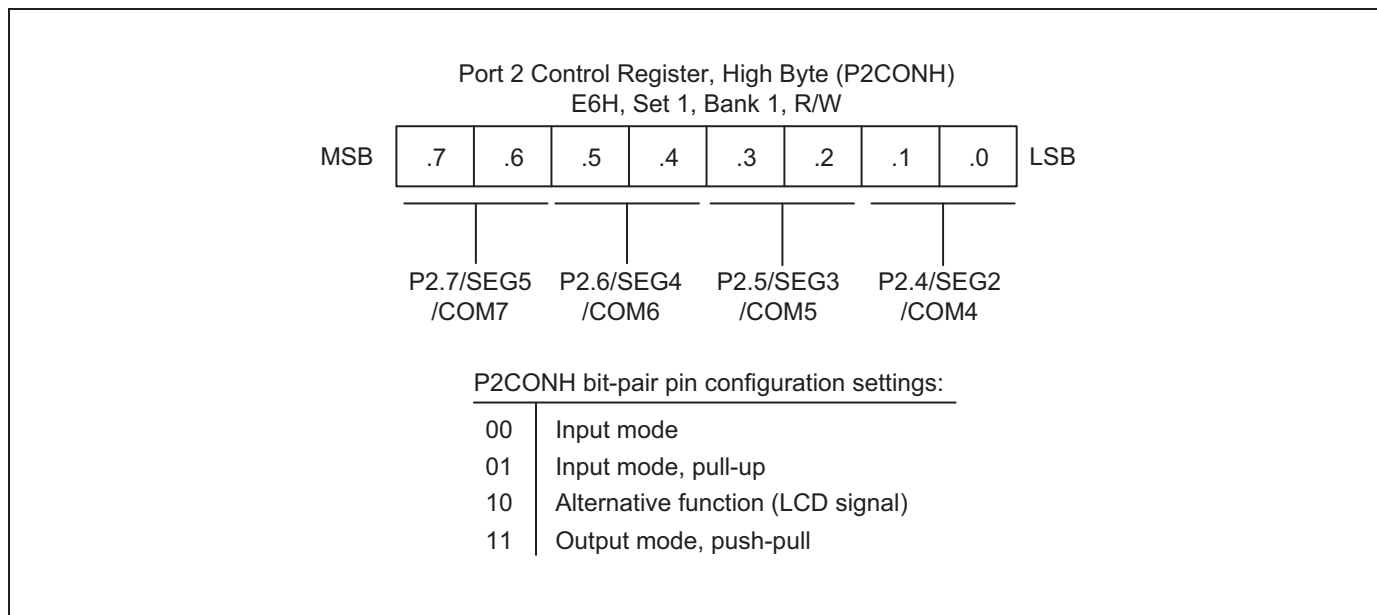
- Low-byte pins (P2.0–P2.3): COM0, COM1, COM2/SEG0, COM3/SEG1
- High-byte pins (P2.4–P2.7): COM4/SEG2, COM5/SEG3, COM6/SEG4, COM7/SEG5

### 9.5.1 Port 2 Control Registers (P2CONH, P2CONL)

Port 2 has two 8-bit control registers: P2CONH for P2.4–P2.7 and P2CONL for P2.0–P2.3. A reset clears the P2CONH and P2CONL registers to "00H" by configuring all pins to input mode. You use control registers settings to select input (with or without pull-ups) or push-pull output mode and enable the alternative functions.

When programming the port, please remember that any alternative peripheral I/O function you configure using the port 2 control registers must also be enabled in the associated peripheral module.

[Figure 9-6](#) illustrates the Port 2 high-byte control register.



**Figure 9-6 Port 2 High-Byte Control Register (P2CONH)**

Figure 9-7 illustrates the Port 2 low-byte control register.

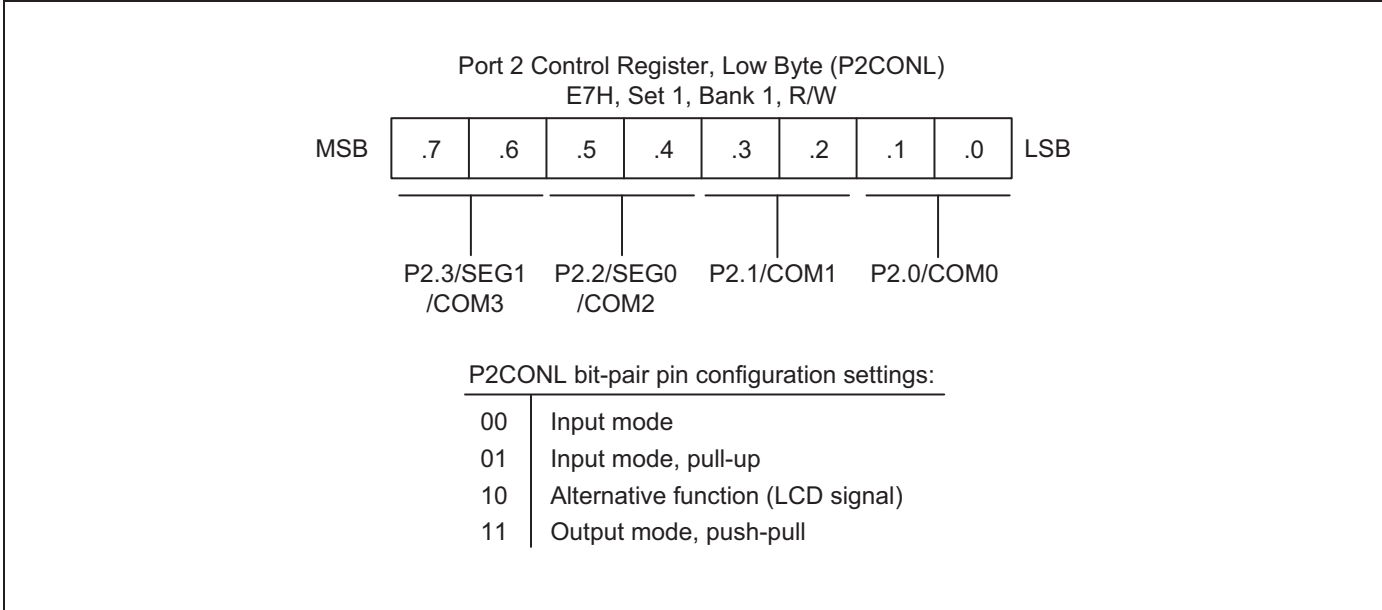


Figure 9-7 Port 2 Low-Byte Control Register (P2CONL)

## 9.6 Port 3

Port 3 is an 8-bit I/O port with individually configurable pins. Port 3 pins are accessed directly by writing or reading the port 3 data register, P3 at location F1H in set 1, bank 1. P3.0–P3.7 can serve as inputs (with or without pull-ups), and outputs (push pull or open-drain). P3.7–P3.0 can serve as segment pins for LCD or you can configure the alternative functions:

- Low-byte pins (P3.0–P3.3): MISO, MOSI, SCK, NSS
- High-byte pins (P3.4–P3.7): INT4/T2OUT/T2CAP, INT5/T2CLK/SDA, INT6/T1CLK/SCL, INT7/T1OUT/T1CAP

### 9.6.1 Port 3 Control Register (P3CONH, P3CONL)

Port 3 has two 8-bit control registers: P3CONH for P3.4–P3.7 and P3CONL for P3.0–P3.3. A reset clears the P3CONH and P3CONL registers to "00H" by configuring all pins to input mode. In input mode, three different selections are available. They are:

- Schmitt trigger input with interrupt generation on falling signal edges.
- Schmitt trigger input with interrupt generation on rising signal edges.
- Schmitt trigger input with interrupt generation on falling/rising signal edges.

When programming the port, please remember that any alternative peripheral I/O function you configure using the port 3 control registers must also be enabled in the associated peripheral module.

### 9.6.2 Port 3 Interrupt Enable and Pending Registers (P3INT, PINTPND)

To process external interrupts at the port 3 pins, the additional control registers are provided:

- port 3 interrupt enable register P3INT (EBH, set 1, bank 1)
- port 3 interrupt pending register PINTPND (F6H, set 1, bank1)

The port 3 interrupt pending register PINTPND enables you to verify for interrupt pending conditions and clears the pending condition when the interrupt service routine has been initiated. The application program detects interrupt requests by polling the PINTPND register at regular intervals.

When the interrupt enable bit of any port 3 pin is "1", a rising or falling signal edge at that pin generates an interrupt request. The corresponding PINTPND bit is then automatically set to "1" Interrupt Request (IRQ) level becomes low to signal the CPU that an interrupt request is waiting. When the CPU acknowledges the interrupt request, application software should clear the pending condition by writing a "0" to the corresponding PINTPND bit.

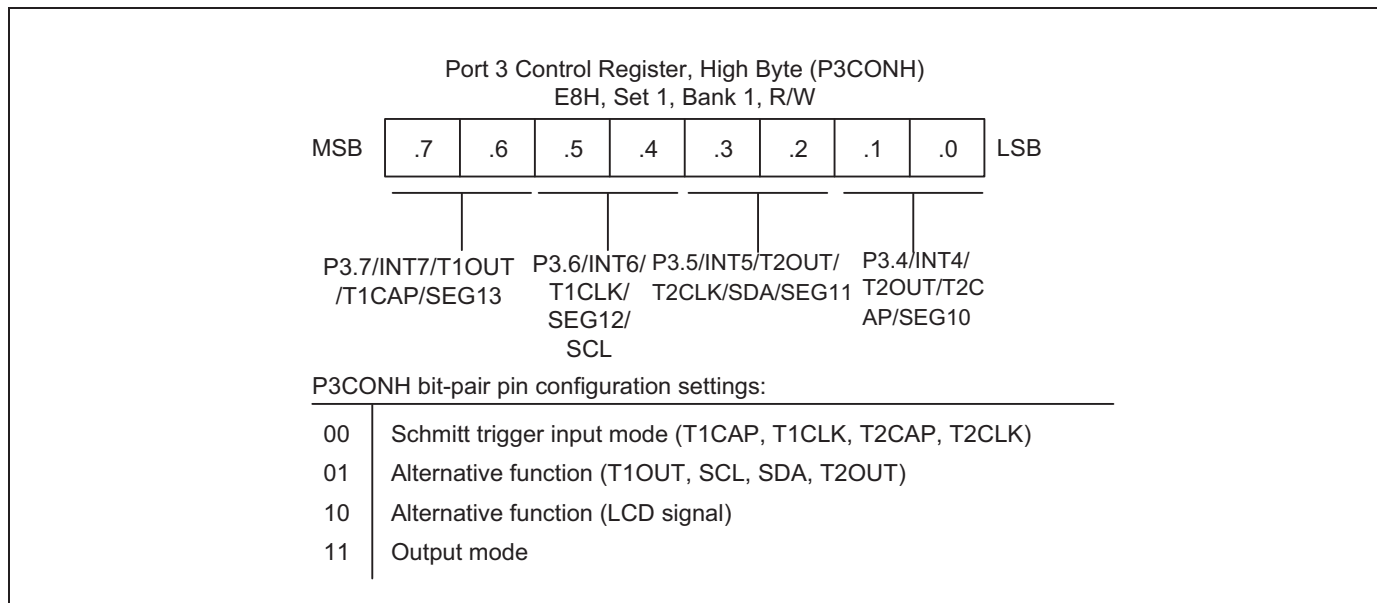
### 9.6.3 Port 3 Pull-Up Resistor Enable Register (P3PUR)

By using the port 3 pull-up resistor enable register, P3PUR (ECH, set1, bank1), you can configure pull-up resistors to individual port 3 pins.

### 9.6.4 Port 3 N-Channel Open-Drain Mode Register (PNE3)

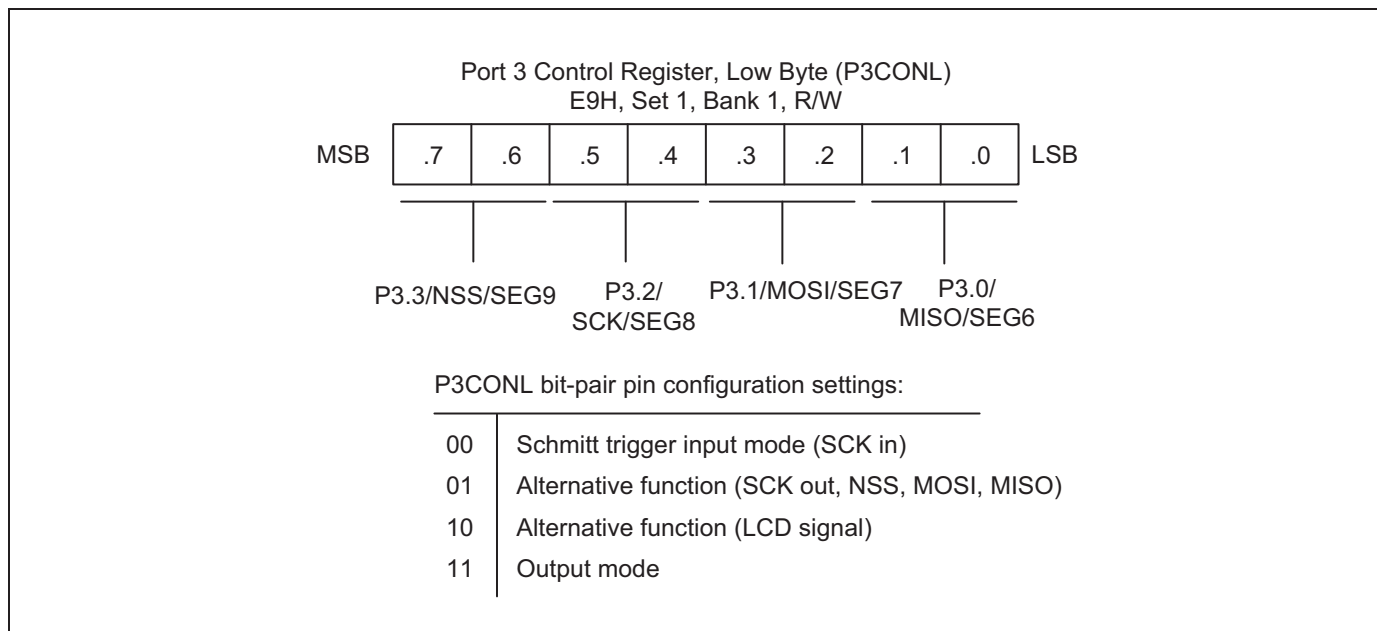
By using the port 3 n-channel open-drain mode register, PNE3 (EAH, set1, bank1), you can configure push-pull or open-drain output mode to individual port 3 pins.

[Figure 9-8](#) illustrates the Port 3 high-byte control register.



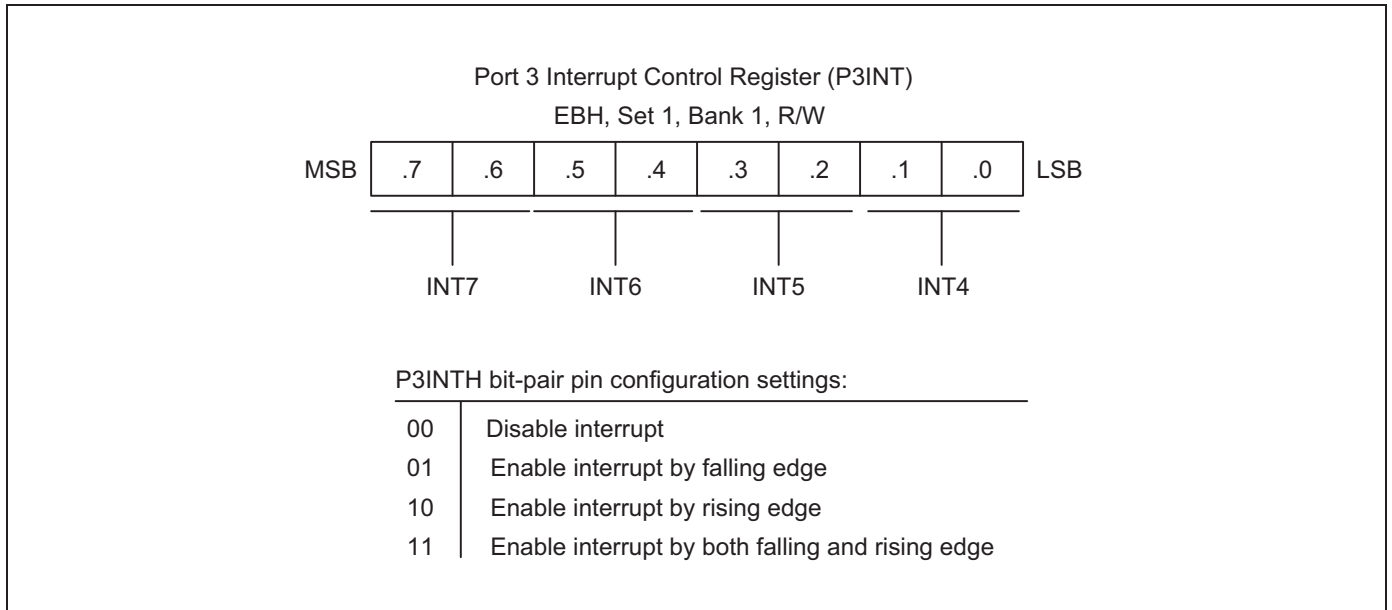
**Figure 9-8 Port 3 High-Byte Control Register (P3CONH)**

[Figure 9-9](#) illustrates the port 3 low-byte control register.



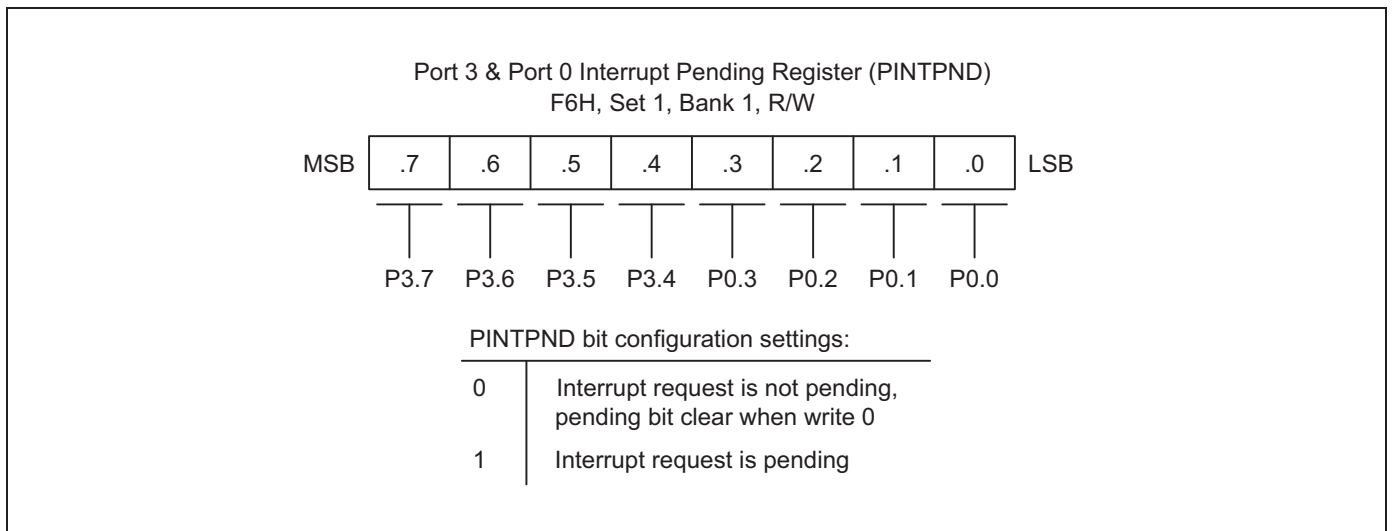
**Figure 9-9 Port 3 Low-Byte Control Register (P3CONL)**

Figure 9-10 illustrates the Port 3 interrupt control register.



**Figure 9-10 Port 3 Interrupt Control Register (P3INT)**

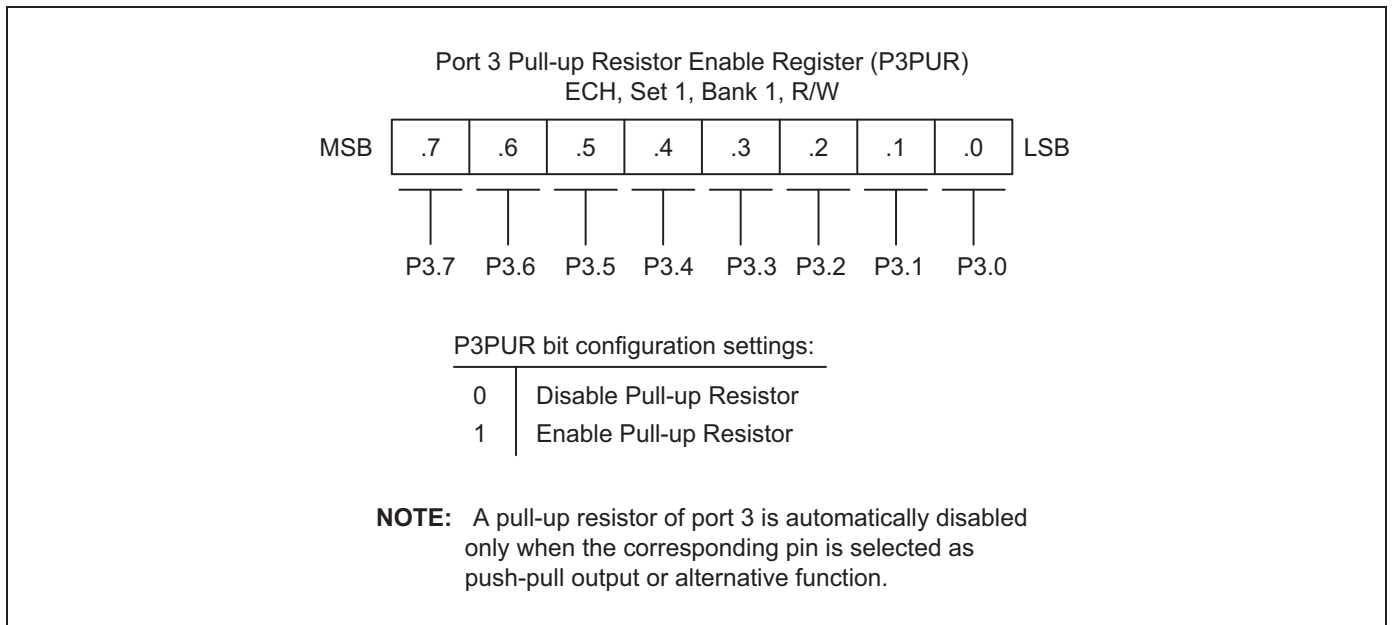
Figure 9-11 illustrates the Port 3 and Port 0 interrupt pending register.



**Figure 9-11 Port 3 and Port 0 Interrupt Pending Register (PINTPND)**

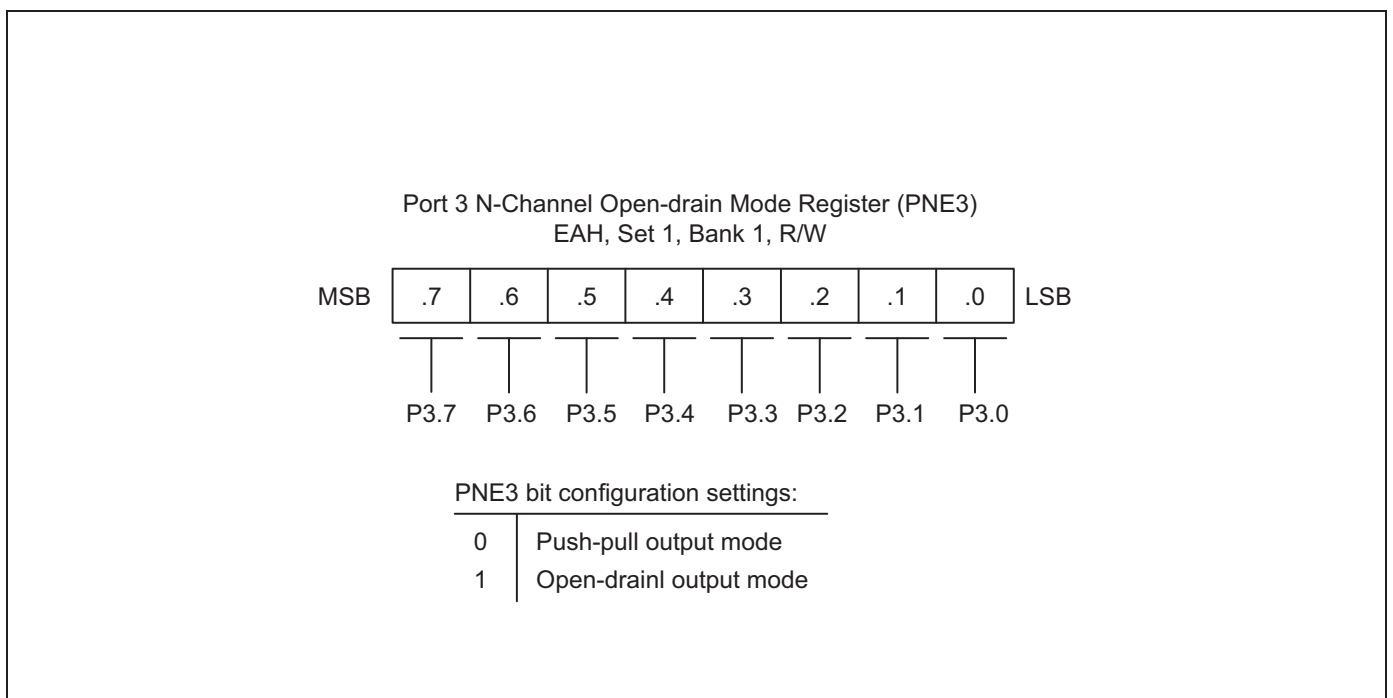


Figure 9-12 illustrates the Port 3 pull-up resistor enable register.



**Figure 9-12 Port 3 Pull-Up Resistor Enable Register (P3PUR)**

Figure 9-13 illustrates the Port 3 N-channel open-drain mode register.



**Figure 9-13 Port 3 N-Channel Open-Drain Mode Register (PNE3)**

## 9.7 Port 4

Port 4 is an 8-bit I/O port with individually configurable pins. Port 4 pins are accessed directly by writing or reading the port 4 data register, P4 at location F5H in set 1, bank 1. P4.0–P4.7 can serve as inputs (with or without pull-ups) and outputs (push pull or open-drain). P4.7–P4.0 can serve as segment pins for LCD or you can configure the alternative functions:

- Low-byte pins (P4.0-P4.3): T0OUT, TBOU, TACLK, TACAP, TAOU
- High-byte pins (P4.4-P4.7): TxD1, RxD1, TxD0, RxD0

### 9.7.1 Port 4 Control Register (P4CONH, P4CONL)

Port 4 has two 8-bit control registers: P4CONH for P4.4–P4.7 and P4CONL for P4.0–P4.3. A reset clears the P4CONH and P4CONL registers to "00H" by configuring all pins to input mode. You use control registers settings to select input or output mode, enable pull-up resistors, select push-pull or open drain output mode and enable the alternative functions.

When programming the port, please remember that any alternative peripheral I/O function you configure using the port 4 control registers should also be enabled in the associated peripheral module.

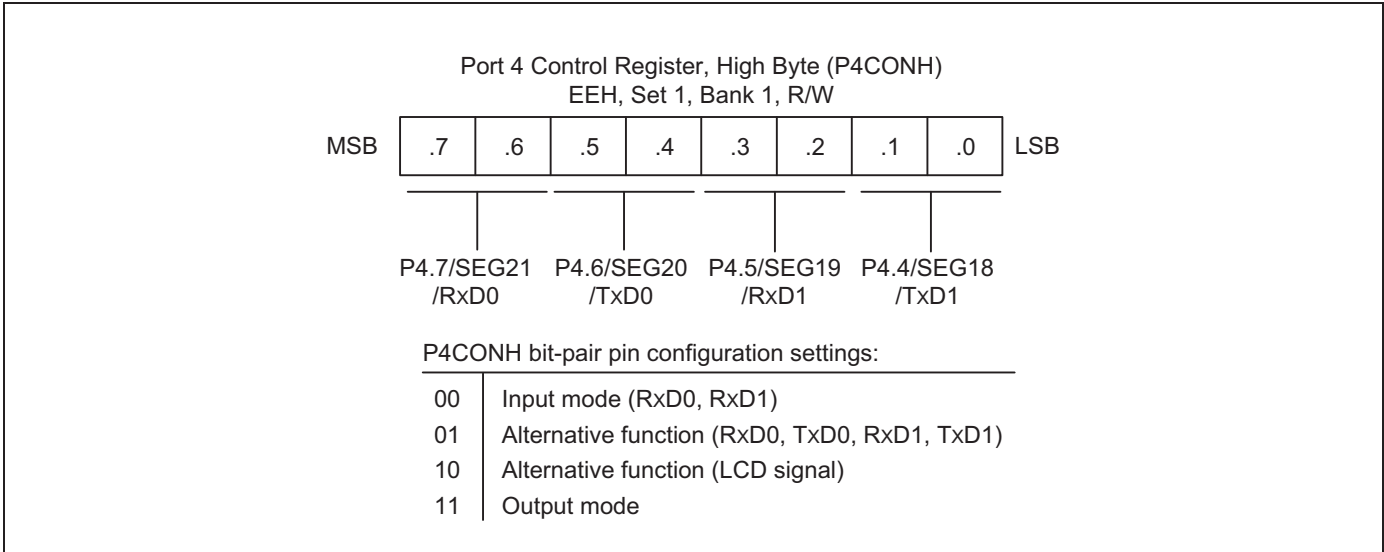
### 9.7.2 Port 4 Pull-Up Resistor Enable Register (P4PUR)

By using the port 4 pull-up resistor enable register, P4PUR (EDH, set1, bank1), you can configure pull-up resistors to individual port 4 pins.

### 9.7.3 Port 4 N-Channel Open-Drain Mode Register (PNE4)

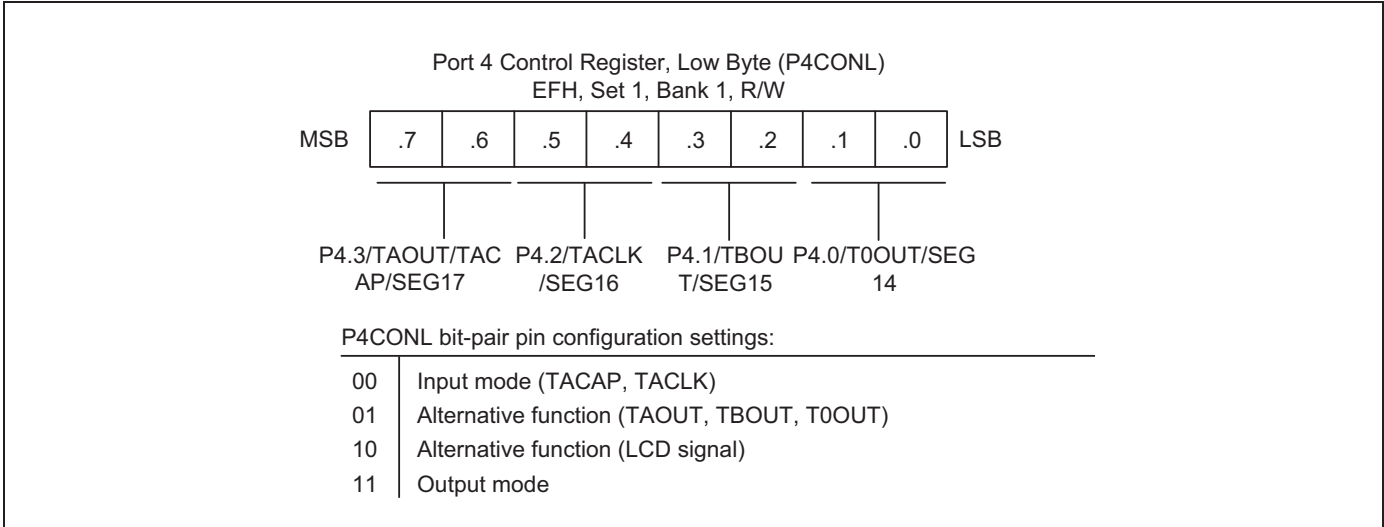
By using the port 4 n-channel open-drain mode register, PNE4 (F0H, set1, bank1), you can configure push-pull or open-drain output mode to individual port 4 pins.

Figure 9-14 illustrates the Port 4 high-byte control register.



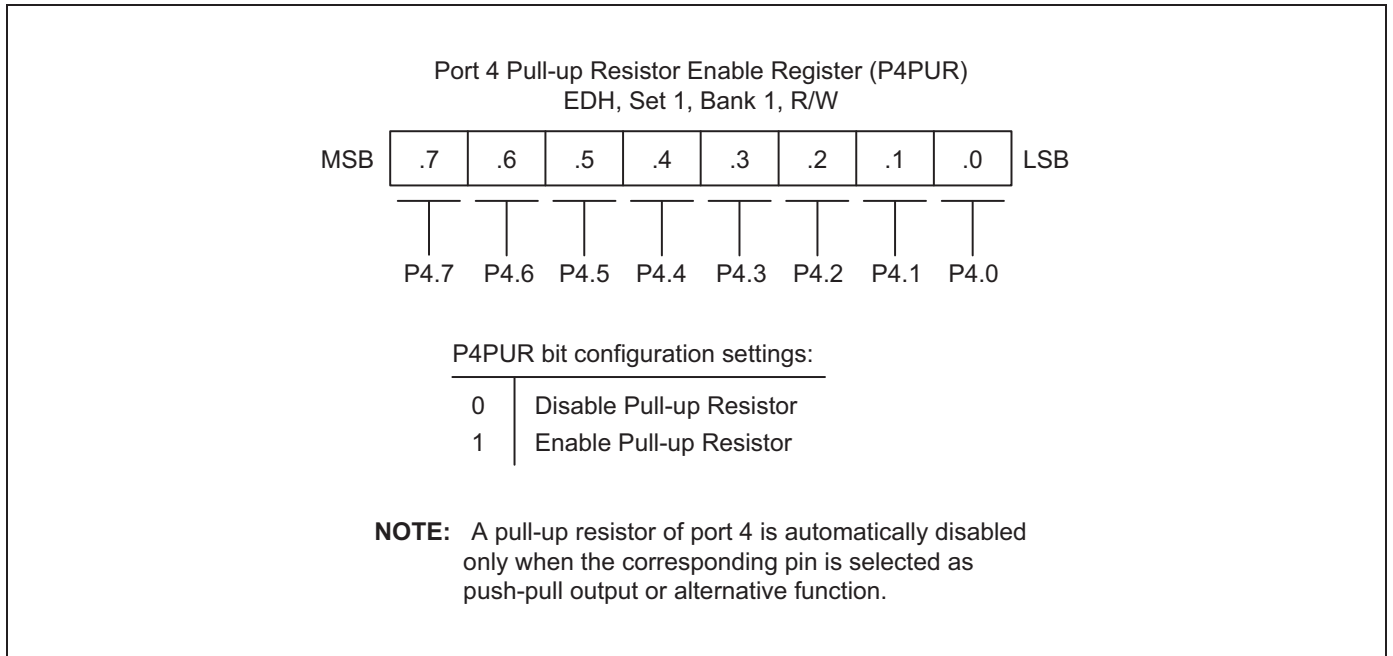
**Figure 9-14 Port 4 High-Byte Control Register (P4CONH)**

Figure 9-15 illustrates the port 4 low-byte control register.



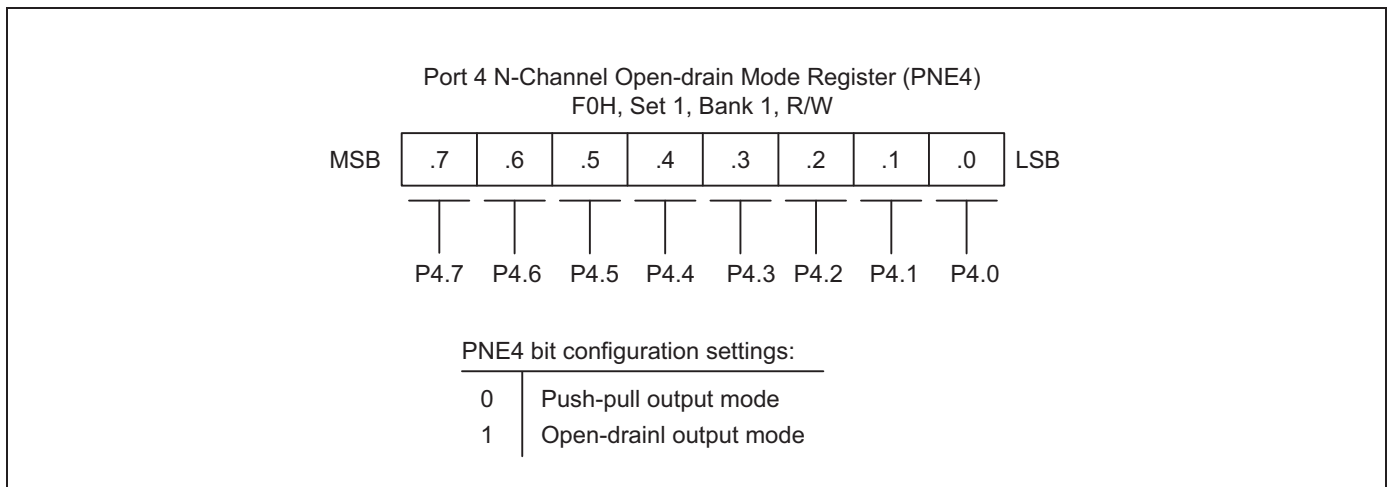
**Figure 9-15 Port 4 Low-Byte Control Register (P4CONL)**

Figure 9-16 illustrates the Port 4 pull-up resistor enable register.



**Figure 9-16 Port 4 Pull-Up Resistor Enable Register (P4PUR)**

Figure 9-17 illustrates the Port 4 N-channel open-drain mode register.



**Figure 9-17 Port 4 N-Channel Open-Drain Mode Register (PNE4)**

# 10

## Basic Timer

### 10.1 Overview

S3F8S19/F8S15 has an 8-bit basic timer.

#### 10.1.1 Basic Timer

You can use the basic timer (BT) in two different ways:

- As a watchdog timer to provide an automatic reset mechanism in the event of a system malfunction.
- To signal the end of the required oscillation stabilization interval after a reset or a Stop mode release.

The functional components of the basic timer block are:

- Clock frequency divider (f<sub>xx</sub> divided by 4096, 1024, 128) with multiplexer
- 8-bit basic timer counter, BTCNT (set 1, Bank 0, FDH, read-only)
- Basic timer control register, BTCON (set 1, D3H, Read/Write)

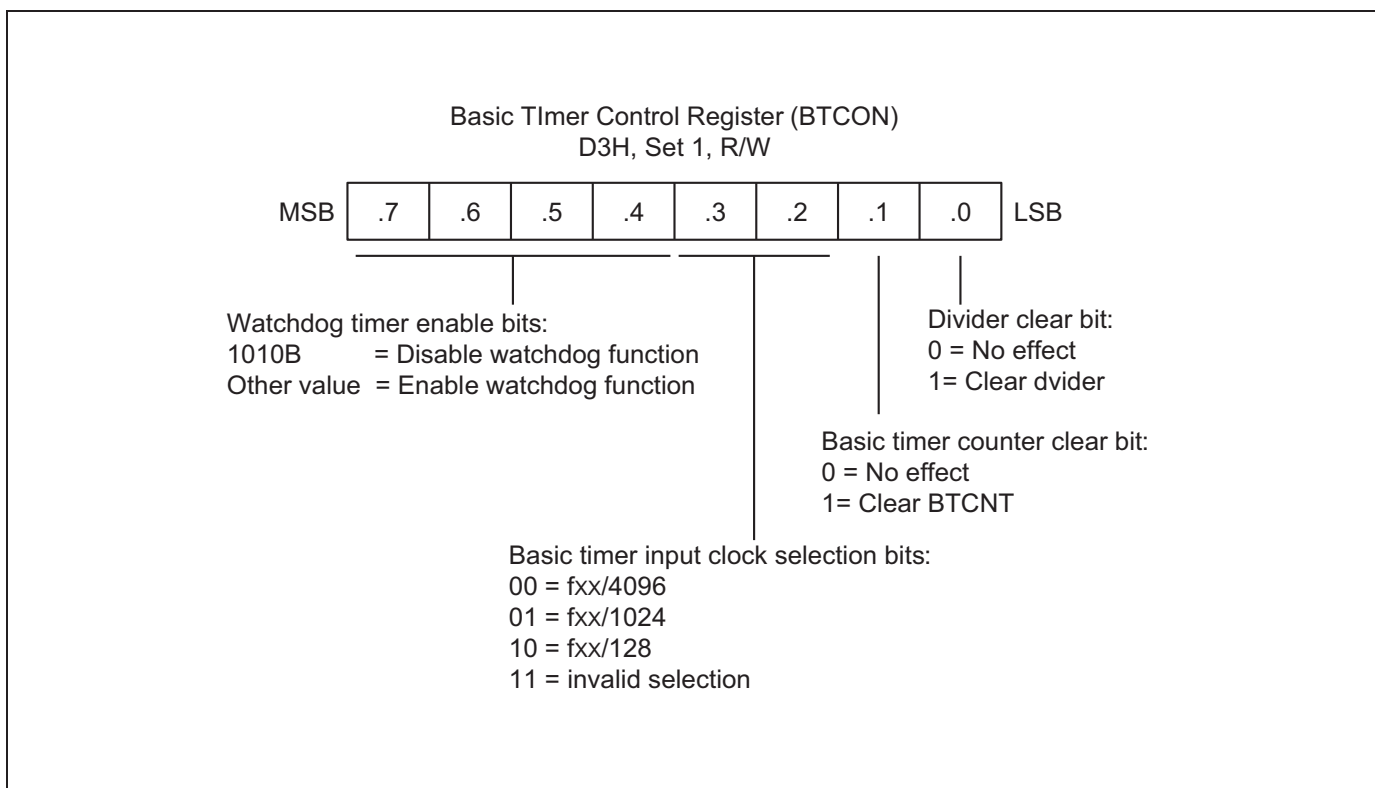
## 10.2 Basic Timer Control Register

The basic timer control register, BTCON, is used to select the input clock frequency to clear the basic timer counter and frequency dividers. It also enables or disables the watchdog timer function. It is located in set 1, address D3H, and is Read/Write addressable using Register addressing mode.

A reset clears BTCON to "00H". This enables the watchdog function and selects a basic timer clock frequency of  $f_{xx}/4096$ . To disable the watchdog function, you should write the signature code "1010B" to the basic timer register control bits BTCON.7–BTCON.4.

You can clear the 8-bit basic timer counter, BTCNT (set 1, bank 0, FDH) at any time during the normal operation by writing a "1" to BTCON.1. To clear the frequency dividers, write a "1" to BTCON.0.

[Figure 10-1](#) illustrates the basic timer control register.



**Figure 10-1 Basic Timer Control Register (BTCON)**

## 10.3 Basic Timer Function Description

This section includes:

- Watchdog timer function
- Oscillation stabilization interval timer function

### 10.3.1 Watchdog Timer Function

You can program the basic timer overflow signal (BTOVF) to generate a reset by setting BTCON.7–BTCON.4 to any value other than "1010B". (The "1010B" value disables the watchdog function). A reset clears BTCON to "00H" and automatically enables the watchdog timer function. A reset also selects the CPU clock (as determined by the current CLKCON register setting) divided by 4096 as the BT clock.

The MCU is reset whenever a basic timer counter overflow occurs. During normal operation, the application program should prevent the overflow, and the accompanying reset operation from occurring. To do this, you should clear BTCNT value (by writing a "1" to BTCON.1) at regular intervals.

If a system malfunction occurs due to circuit noise or some other error condition, the BT counter clear operation will not be executed and a basic timer overflow occurs, initiating a reset. Alternatively, during the normal operation, a BTCNT clear instruction always breaks the basic timer overflow loop (a bit 7 overflow of the 8-bit basic timer counter, BTCNT). If a malfunction occurs, a reset is triggered automatically.

### 10.3.2 Oscillation Stabilization Interval Timer Function

You can also use the basic timer to program a specific oscillation stabilization interval after a reset or when an external interrupt releases stop mode.

In stop mode, whenever a reset or an external interrupt occurs, the oscillator starts. The BTCNT value then starts increasing at the rate of  $f_{xx}/4096$  (for reset), or at the rate of the preset clock source (for an external interrupt). When BTCNT.4 overflows, a signal is generated to indicate that it elapses the stabilization interval and to gate the clock signal off to the CPU so that it can resume the normal operation.

In summary, the events that occur when stop mode is released:

1. During the stop mode, a power-on reset or an external interrupt occurs to trigger the Stop mode release and oscillation starts.
2. If a power-on reset occurs, the basic timer counter increases at the rate of  $f_{xx}/4096$ . If an interrupt is used to release stop mode, the BTCNT value increases at the rate of the preset clock source.
3. Clock oscillation stabilization interval begins and continues until bit 4 of the basic timer counter overflows.
4. When a BTCNT.4 overflow occurs, the normal CPU operation resumes.

Figure 10-2 illustrates the basic timer block diagram.

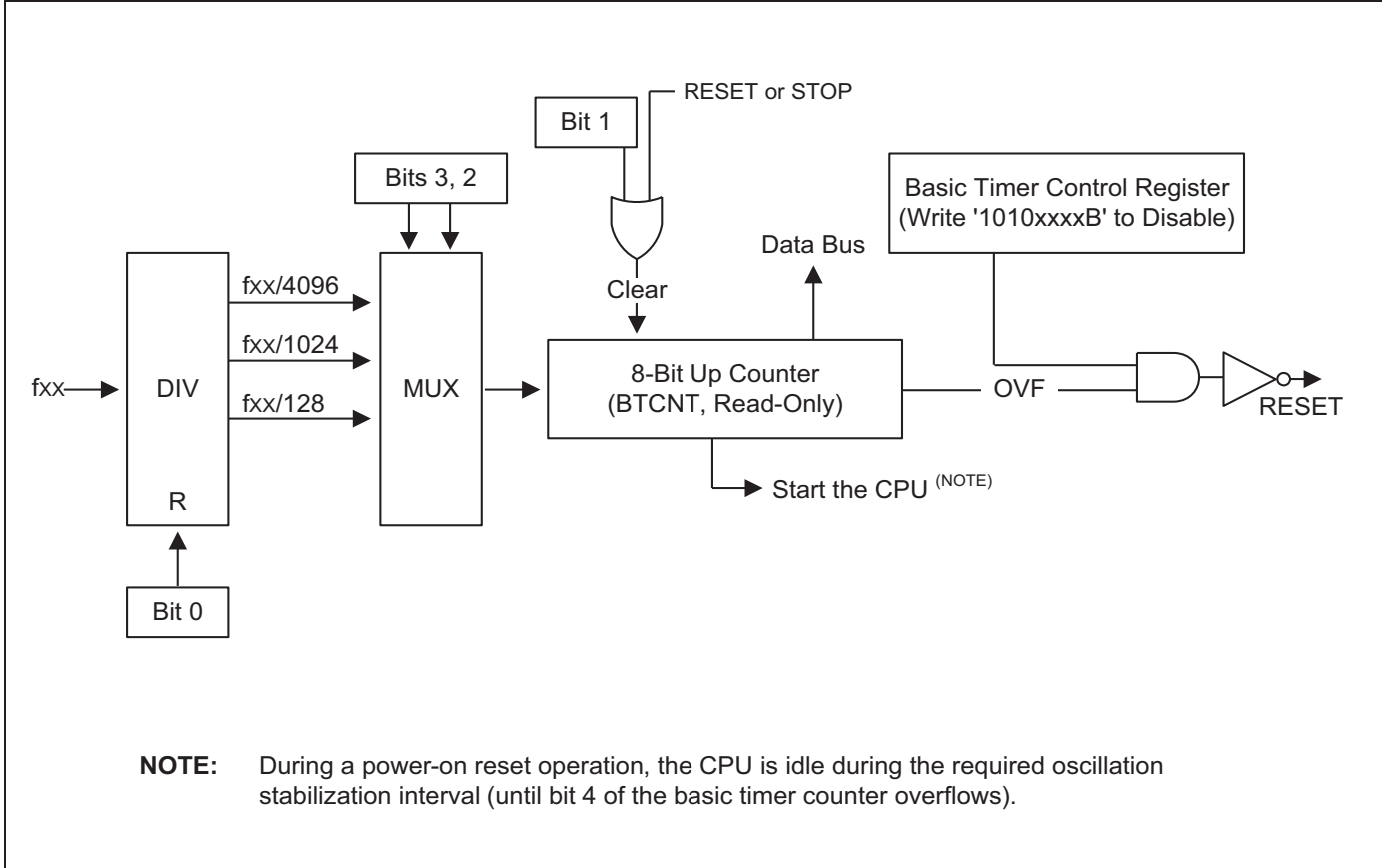


Figure 10-2 Basic Timer Block Diagram



# 11

## 8-Bit Timer A

### 11.1 Overview

The 8-bit timer A is an 8-bit general-purpose timer/counter.

Timer A has three operating modes; you can select one of the modes using appropriate TACON setting.

The settings are:

- Interval timer mode (Toggle output at TAOUT pin)
- Capture input mode with a rising or falling edge trigger at the TACAP pin
- PWM mode (TAOUT)

The functional components of Timer A are:

- Clock frequency divider (f<sub>clk</sub> divided by 1024, 256, 64, 8 or 1) with multiplexer
- External clock input pin (TACLK)
- 8-bit counter (TACNT), 8-bit comparator, and 8-bit reference data register (TADATA)
- I/O pins for capture input (TACAP) or PWM or match output (TAOUT)
- Timer A overflows interrupt (IRQ0 vector D0H) and matches/captures interrupt (IRQ0 vector CEH) generation
- Timer A control register, TACON (set 1, Bank 0, E2H, and Read/Write)
- Timer A pre-scalar register and TAPS (set 1, Bank 0, E3H, and Read/Write)

## 11.2 Timer A Control Register (TACON)

You use the timer A control register, TACON, to:

- Select the timer A operating mode (interval timer, capture mode or PWM mode)
- Select the timer A input clock frequency
- Clear the timer A counter and TACNT
- Enable the timer A overflow interrupt or timer A match/capture interrupt

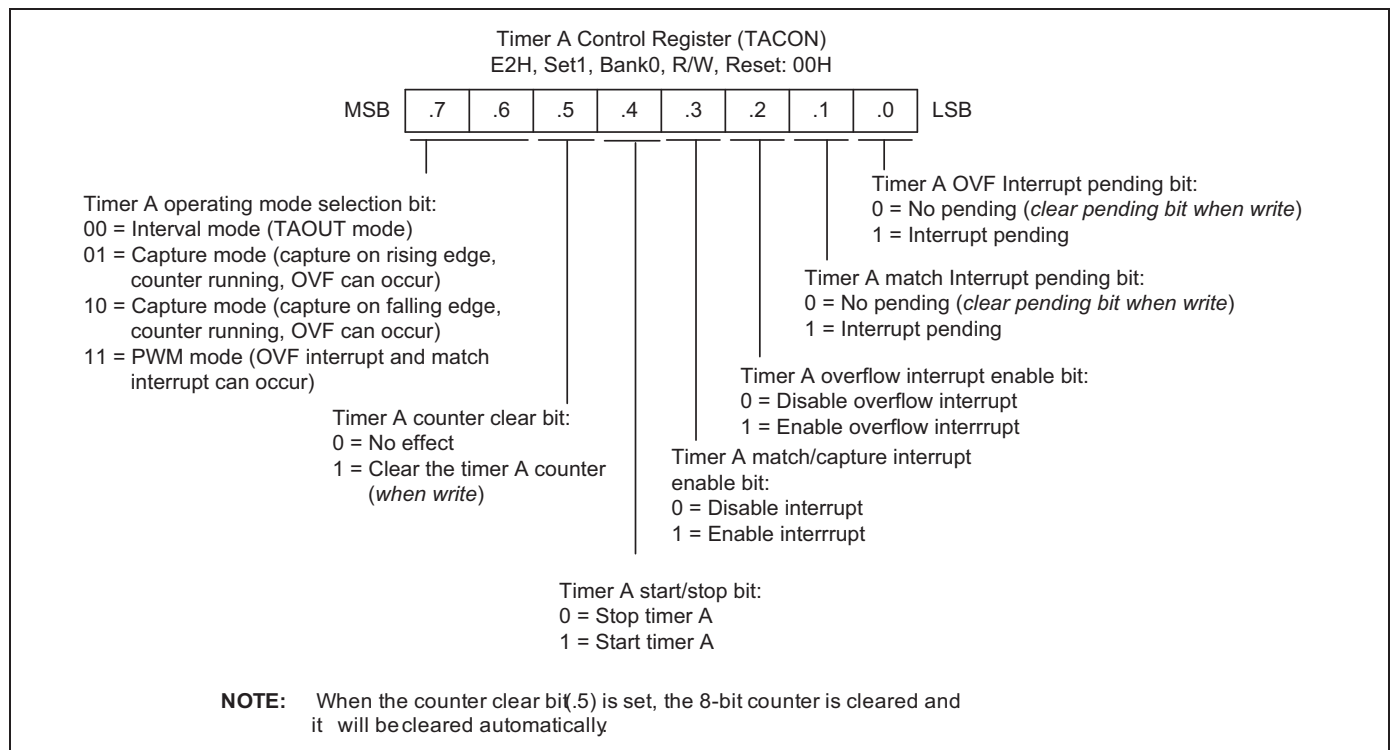
TACON is located in set 1, Bank 0 at address E2H and is Read/Write addressable using Register addressing mode.

A reset clears TACON to "00H". This sets timer A to normal interval timer mode, selects an input clock frequency of f<sub>xx</sub>, and disables all timer A interrupts. You can clear the timer A counter at any time during normal operation by writing "1" to TACON.5.

The timer A overflow interrupt (TAOVF) in interrupt level IRQ0 and have the vector address D0H. When a timer A overflow interrupt occurs and is serviced by the CPU, the pending condition is cleared automatically by hardware or must be cleared by software.

To enable the timer A match/capture interrupt (IRQ0, vector CEH), you should write TACON.3 to "1". To detect a match/capture interrupt pending condition, the application program polls TACON.1. When a "1" is detected, a timer A match or capture interrupt is pending. When the interrupt request has been serviced, the pending condition should be cleared by software by writing a "0" to the timer A match/capture interrupt pending bit, TACON.1.

[Figure 11-1](#) illustrates the timer A control register.



**Figure 11-1 Timer A Control Register (TACON)**

Figure 11-2 illustrates the timer A pre-scalar register.

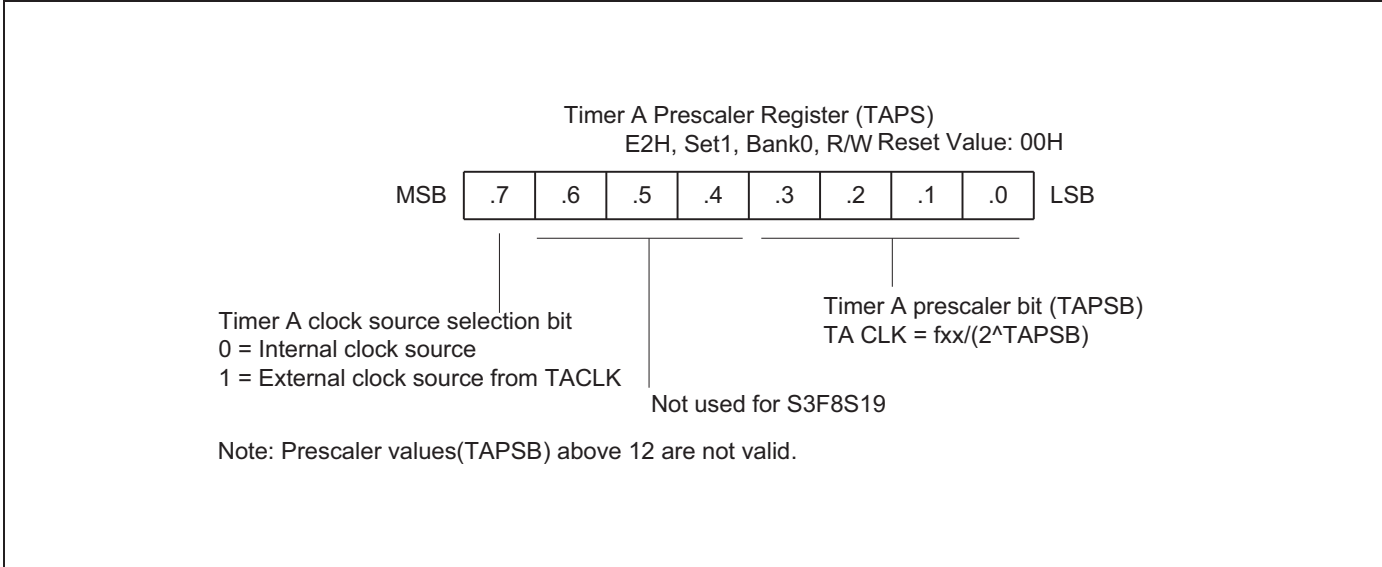


Figure 11-2 Timer A Pre-scalar Register (TAPS)

## 11.3 Function Description

This section includes:

- Timer A interrupts
- Interval timer function
- Pulse width modulation mode
- Capture mode

### 11.3.1 Timer A Interrupts

The timer A module can generate two interrupts:

- Timer A overflow interrupt (TAOVF)
- Timer A match/capture interrupt (TAINT)

Timer A overflow interrupt can be cleared by both software and hardware and match/capture interrupt pending conditions are cleared by software when it has been serviced.

### 11.3.2 Interval Timer Function

The timer A module can generate an interrupt: the timer A match interrupt (TAINT).

When timer A interrupt occurs and is serviced by the CPU, the pending condition should be cleared by software.

In interval timer mode, a match signal is generated and TAOUT is toggled when the counter value is identical to the value written to the Timer A reference data register, TADATA. The match signal generates a timer A match interrupt and clears the counter.

If, for example, you write the value 10H to TADATA and 0BH to TACON, the counter increments until it reach 10H. At this point the TA interrupt request is generated; resets the counter value, and resumes counting.

### 11.3.3 Pulse Width Modulation Mode

Pulse width modulation (PWM) mode lets you program the width (duration) of the pulse that is output at the TAOUT pin. As in interval timer mode, a match signal is generated when the counter value is identical to the value written to the timer A data register. In PWM mode, however, the match signal does not clear the counter. Instead, it runs continuously, overflowing at 0xFFH, and then continues incrementing from 00H.

Although you can use the match signal to generate a timer A overflow interrupt, interrupts are not typically used in PWM-type applications. Instead, the pulse at the TAOUT pin is held to Low level as long as the reference data value is less than or equal to ( $\leq$ ) the counter value. The pulse is held to High level for as long as the data value is greater than ( $>$ ) the counter value. One pulse width is equal to  $t_{CLK} \times 256$ .

#### 11.3.4 Capture Mode

In capture mode, a signal edge that is detected at the TACAP pin opens a gate and loads the current counter value into the Timer A data register. You can select rising or falling edges to trigger this operation.

Timer A also gives you capture input source: the signal edge at the TACAP pin. You can select the capture input by setting the value of the timer A capture input selection bit in P4CONL, (EAH, Set1 Bank1). When P4CONL.7–.6 is 00, the TACAP input or normal input is selected.

You can use both types of timer A interrupts in capture mode: the timer A overflow interrupt is generated whenever a counter overflow occurs; the timer A match/capture interrupt is generated when the counter value is loaded into the Timer A data register.

By reading the captured data value in TADATA, and assuming a specific value for the timer A clock frequency, you can calculate the pulse width (duration) of the signal that is being input at the TACAP pin.

## 11.4 Block Diagram

Figure 11-3 illustrates the timer A functional block diagram.

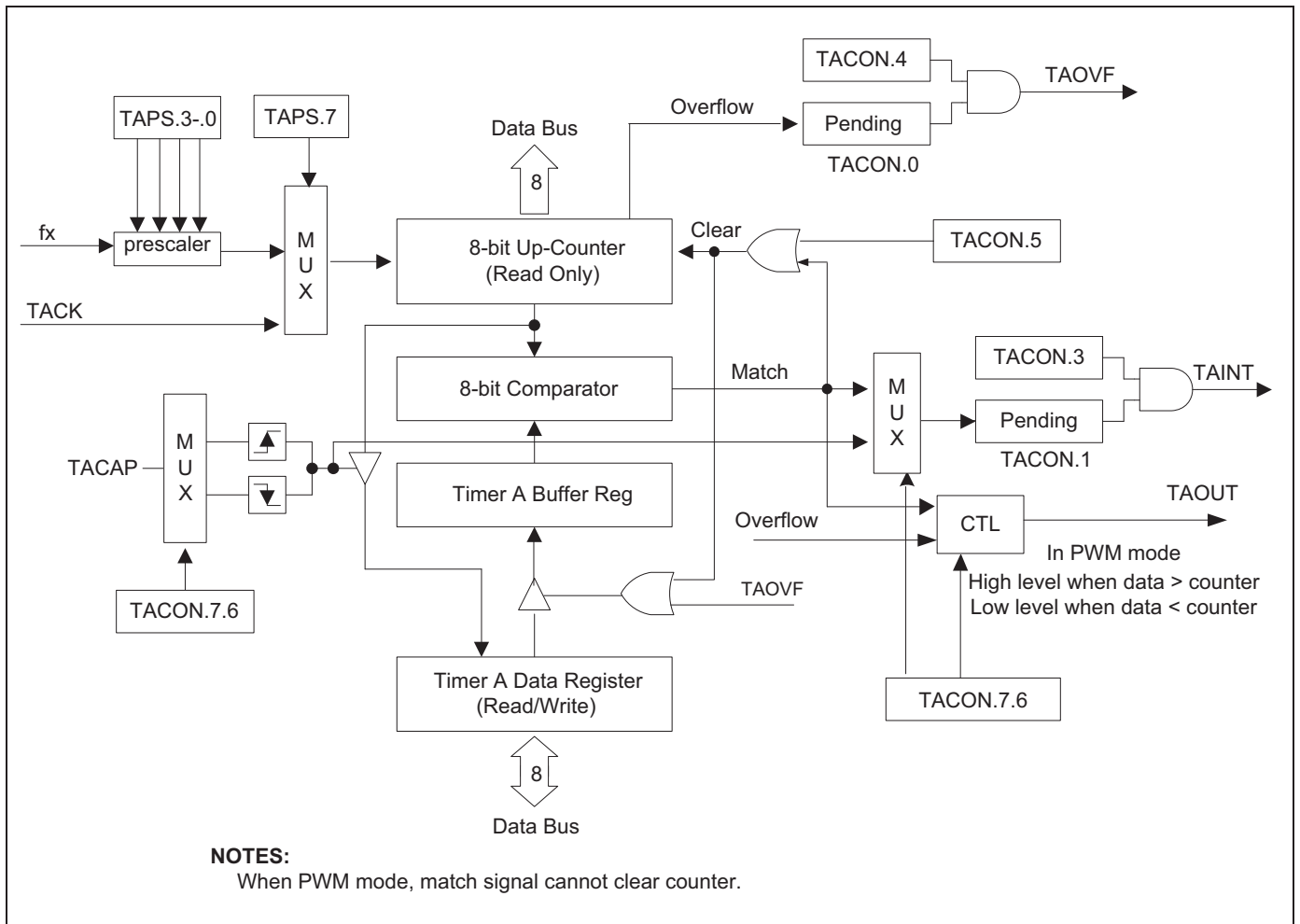


Figure 11-3 Timer A Functional Block Diagram

# 12 STOP Wake-Up Timer

## 12.1 Overview

The S3F8S19/F8S15 microcontroller has a 10-bit STOP Wake-up Timer (SWT). The features of SWT are:

- Use this only in STOP mode
- Use Ring OSC as clock source
- Generates interrupt to wake up CPU from STOP mode.
- Selectable clock divider

### 12.1.1 Function Description

The SWT works only in stop mode. A 32 kHz internal Ring Oscillator works as its clock source in stop mode. The SWT can wake up CPU from stop mode when the counter reaches 0x3FF. And then, CPU will continue to execute the instruction next to STOP instruction after SWT interrupt service routine returns.

### 12.1.2 STOP Wake-Up Timer Control Register

You can use the STOP Wake-up Timer Control Register (SWTCON) to:

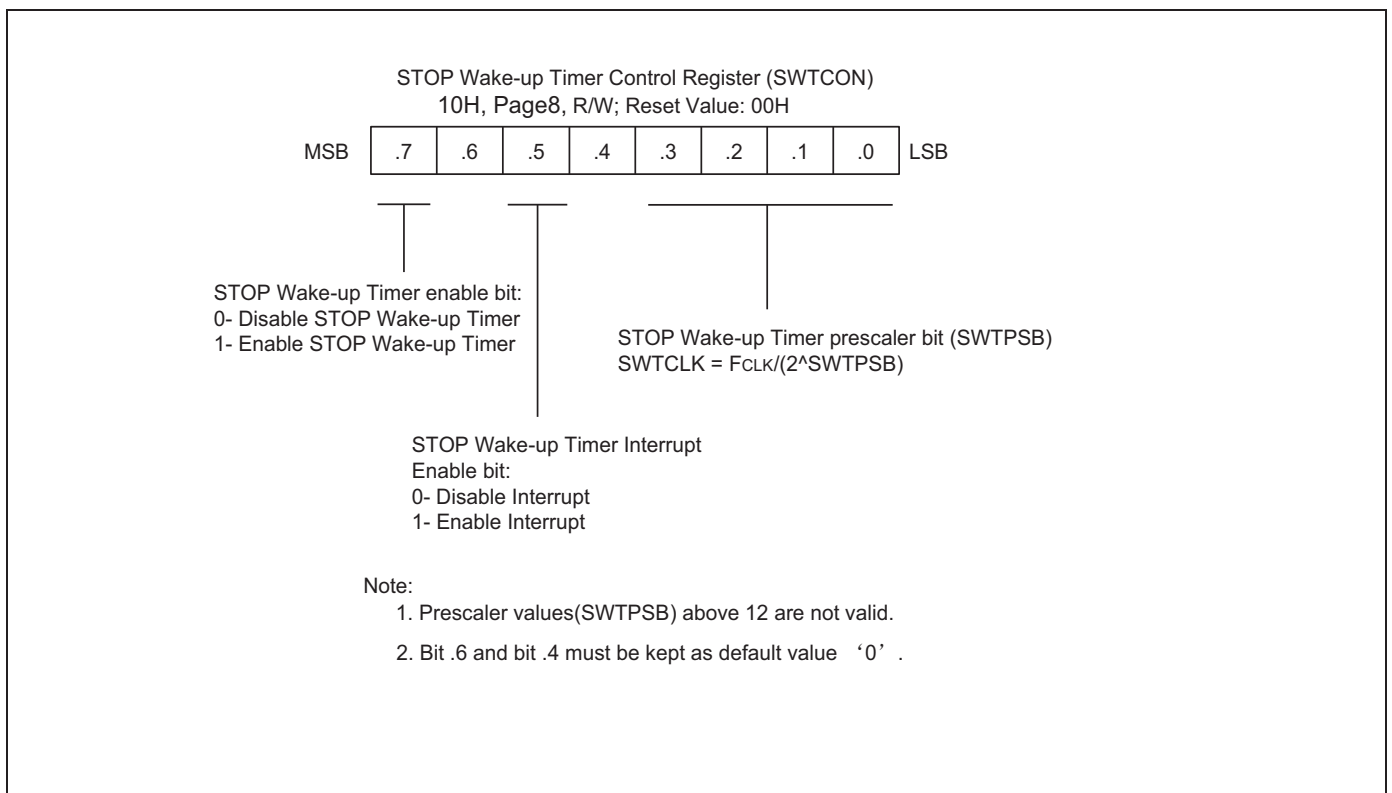
- Enable/Disable STOP Wake-up Timer
- Interrupt Enable/Disable.
- Program the clock pre-scaler for STOP Wake-up Timer.

SWTCON is located at address 10H, Page8, and is Read/Write addressable by using Register addressing mode. A reset clears SWTCON to "00H". This disables STOP Wake-up Timer and STOP Wake-up interrupt.

You can enable STOP Wake-up Timer by writing a "1" to SWTCON.7. SWTCON.5 controls the STOP Wake-up Timer interrupt when counter reaches to 0x3FF.

You can use SWTCON.3-0 to set the clock pre-scaler of STOP Wake-up Timer. You should not keep the clock prescaler value of SWTPS more than 12. Any value more than 12 is invalid.

[Figure 12-1](#) illustrates the STOP wake-up timer control register.



**Figure 12-1 STOP Wake-Up Timer Control Register (SWTCON)**



Figure 12-2 illustrates the functional block diagram of STOP wake-up timer.

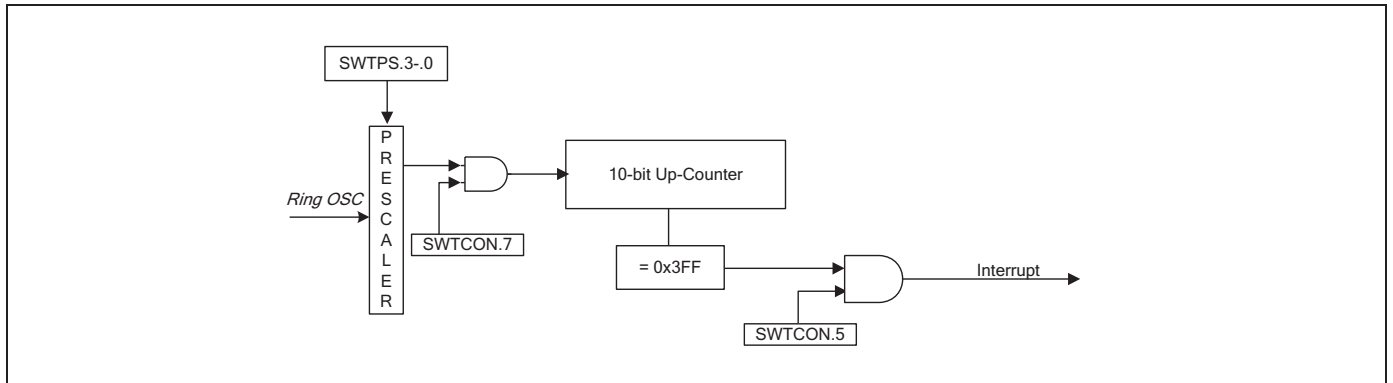


Figure 12-2 STOP Wake-Up Timer Functional Block Diagram

Table 12-1 lists the STOP wake-up timer pre-scalar select.

Table 12-1 STOP Wake-Up Timer Presaler Select

| SWTCN.3 | SWTCN.2 | SWTCN.1 | SWTCN.0 | Number of 32 kHz Ring OSC Cycles | Typical Time-Out |
|---------|---------|---------|---------|----------------------------------|------------------|
| 0       | 0       | 0       | 0       | 2048                             | 64 ms            |
| 0       | 0       | 0       | 1       | 4096                             | 128 ms           |
| 0       | 0       | 1       | 0       | 8109                             | 256 ms           |
| 0       | 0       | 1       | 1       | 16384                            | 512 ms           |
| 0       | 1       | 0       | 0       | 32768                            | 1024 ms          |
| 0       | 1       | 0       | 1       | 65536                            | 2048 ms          |
| 0       | 1       | 1       | 0       | 131072                           | 4096 ms          |
| 0       | 1       | 1       | 1       | 262144                           | 8192 ms          |
| 1       | 0       | 0       | 0       | 524288                           | 16384 ms         |
| 1       | 0       | 0       | 1       | 1048576                          | 32768 ms         |
| 1       | 0       | 1       | 0       | 2097152                          | 65536 ms         |

### 12.1.3 Stop Mode Wake Up

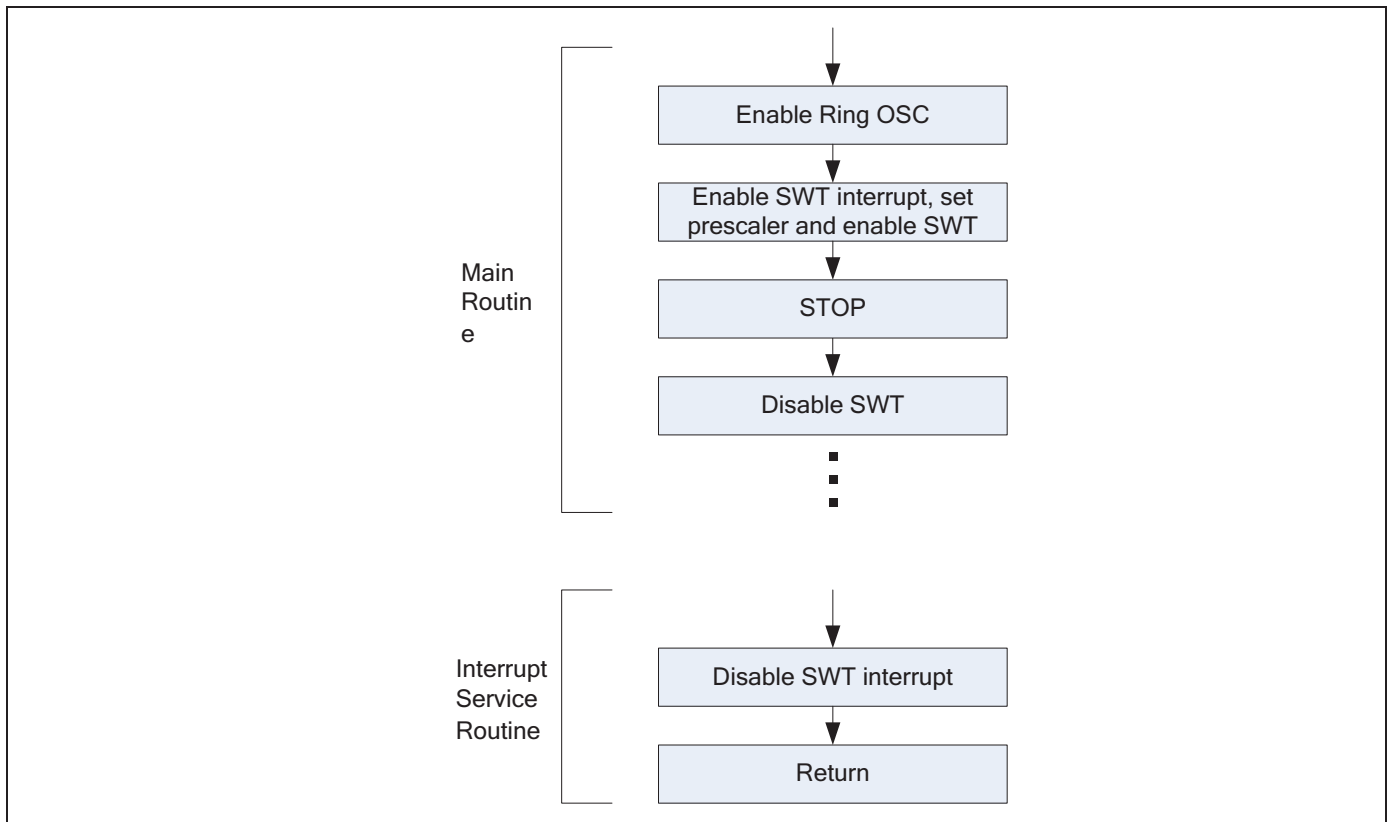
Before entering STOP mode, you should follow these steps to set up the STOP mode Wake-up Timer:

1. Enable Ring OSC by setting ROSCCON to 0xc0.
2. Enable STOP mode Wake-up Timer and its interrupt. Set the pre-scaler to determine the wake-up time.
3. Enter the STOP mode immediately after SWT starts.

The CPU then will stop and STOP Wake-up Timer Continues counting until it reaches 0x3FF (10-bit). The SWT interrupt wakes CPU up and execute its interrupt service routine.

1. Disables STOP Wake-up Timer interrupt.
2. Does not allow other instructions.
3. Interrupt return.

[Figure 12-3](#) illustrates the SWT operation sequence.



**Figure 12-3** SWT Operation Sequence

**Example 12-1 Using STOP Wake-Up Timer**

```

;-----<< Interrupt Vector Address >>
        VECTOR CCH, INT_SWT

;-----<< Smart Option >>
        ORG    003CH
        DB     0FFH           ; 003CH, must be initialized to FF
        DB     0FFH           ; 003DH, must be initialized to FF
        DB     0FFH           ; 003EH, Normal reset vector, ISP disabled
        DB     018H           ; 003FH, LVR disabled, external OSC
        ORG    0100H
RESET: DI                       ; disable interrupt
        LD     BTCN, #10100011B ; Watchdog disable
        .
        .
        .
        EI                       ; Enable interrupt

;-----<< Main loop >>
MAIN:  .
        .
        .
        SB1
        LD     STPCON, #01011010B
        LD     ROSCCON, #11000000B           ; Ring OSC enabled
        LD     PP, #88H
        LD     SWTCN, #10100000B           ; SWT enabled, interrupt enabled, SWTPSB=0
        STOP                    ; Immediately after SWT enable
        NOP
        NOP
        AND    SWTCN, #00001111B           ; Disable SWT
        LD     PP, #00H
        .
        .
        .
        JR     t, MAIN

;-----<< Interrupt Service Routine >>
INT_SWT:
        LD     PP, #88H
        AND    SWTCN, #00001111B           ; Disable SWT interrupt
        LD     PP, #00H
        IRET

```

# 13

## 16-Bit Timer 0/1/2/B

### 13.1 Overview

The 16-bit timer 0 is a 16-bit general-purpose timer/counter.

Timer 0 has two operating modes:

- Interval timer mode (Toggle output at T0OUT pin): Only match interrupt occurs
- Pulse Width Modulation (PWM) mode (T0OUT/T0PWM pin): Match and overflow interrupt can occur

You can select one of these modes by using the appropriate T0CON setting:

The functional components of Timer 0 are:

- Clock frequency divider with pre-scalar(T0PS)
- 16-bit counter, 16-bit comparator, and 16-bit reference data register (T0DATAH/L)
- PWM or match output (T0OUT)
- Timer 0 overflow interrupt (IRQ2, vector D6H) and match interrupt (IRQ2, vector D4H) generation
- Timer 0 control register, T0CON (set 1, bank0, ECH, read/write)

### 13.2 Timer 0 Control Register

You can use the timer 0 control register (T0CON) to:

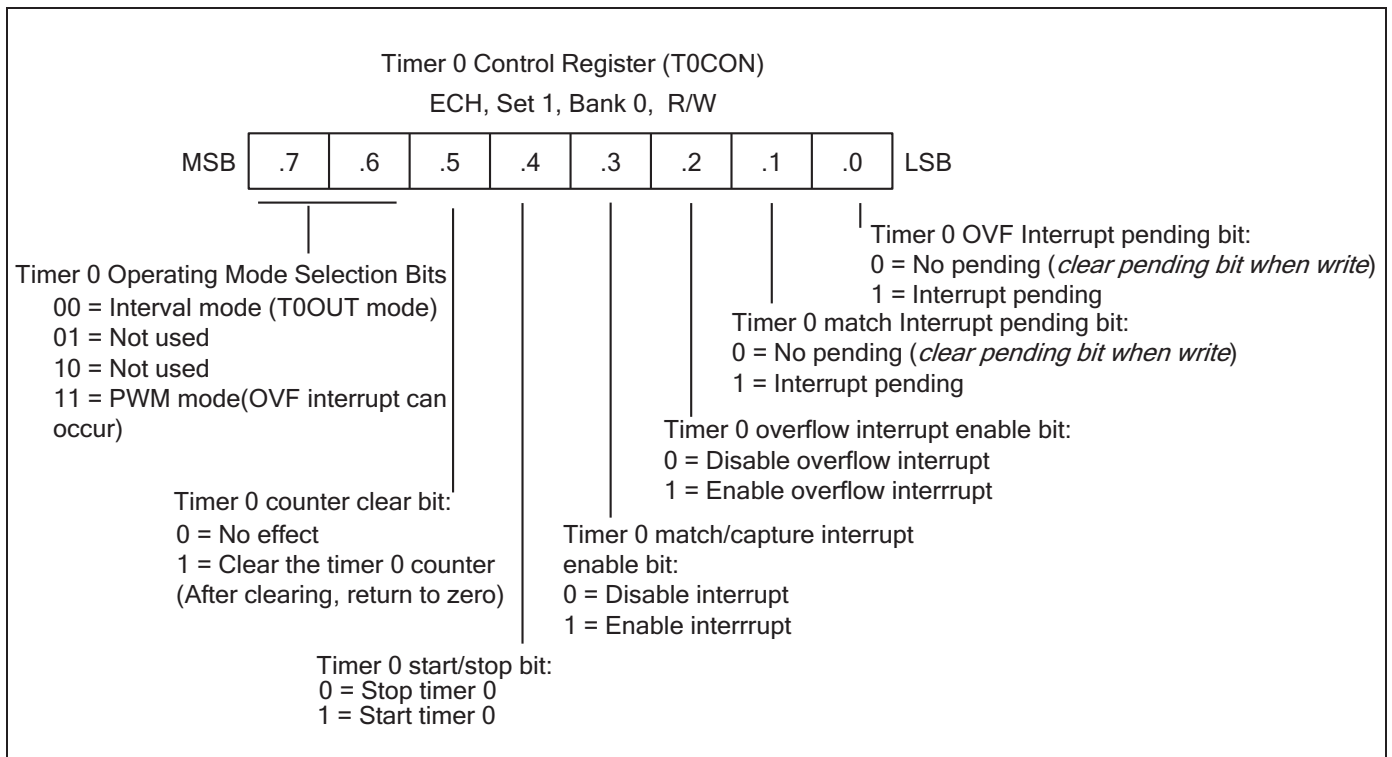
- Select the timer 0 operating mode (PWM mode or interval mode)
- Select the timer 0 4 bits pre-scalar
- Clear the timer 0 counter, T0CNT
- Enable the timer 0 match/overflow interrupt
- Start the timer 0

T0CON is located in set 1, Bank 0 at address ECH, and is read/write addressable that uses the Register addressing mode.

A reset clears T0CON to "00H". This sets timer 0 to interval mode, selects fxx, stops timer 0, and disables all timer 0 interrupts. You can clear the timer 0 counter at any time during normal operation by writing a "1" to T0CON.3.

To enable the timer 0 match/overflow interrupt (IRQ2, vector D4H), you should write T0CON.7 and T0CON.5 to "1". To generate the exact time interval, you should write T0CON.5 and 1, which clears counter and interrupt pending bit. To detect an interrupt pending condition when T0INT is disabled, the application program should poll the pending bit, T0CON.2. When a "1" is detected, a timer 0 match/overflow interrupt is pending. When the T0INT sub-routine has been serviced, the pending condition must be cleared by software by writing a "0" to the timer 0 interrupt pending bit, T0CON.1.

[Figure 13-1](#) illustrates the Timer 0 control register.



**Figure 13-1 Timer 0 Control Register (T0CON)**

Figure 13-2 illustrates the Timer 0 pre-scalar register.

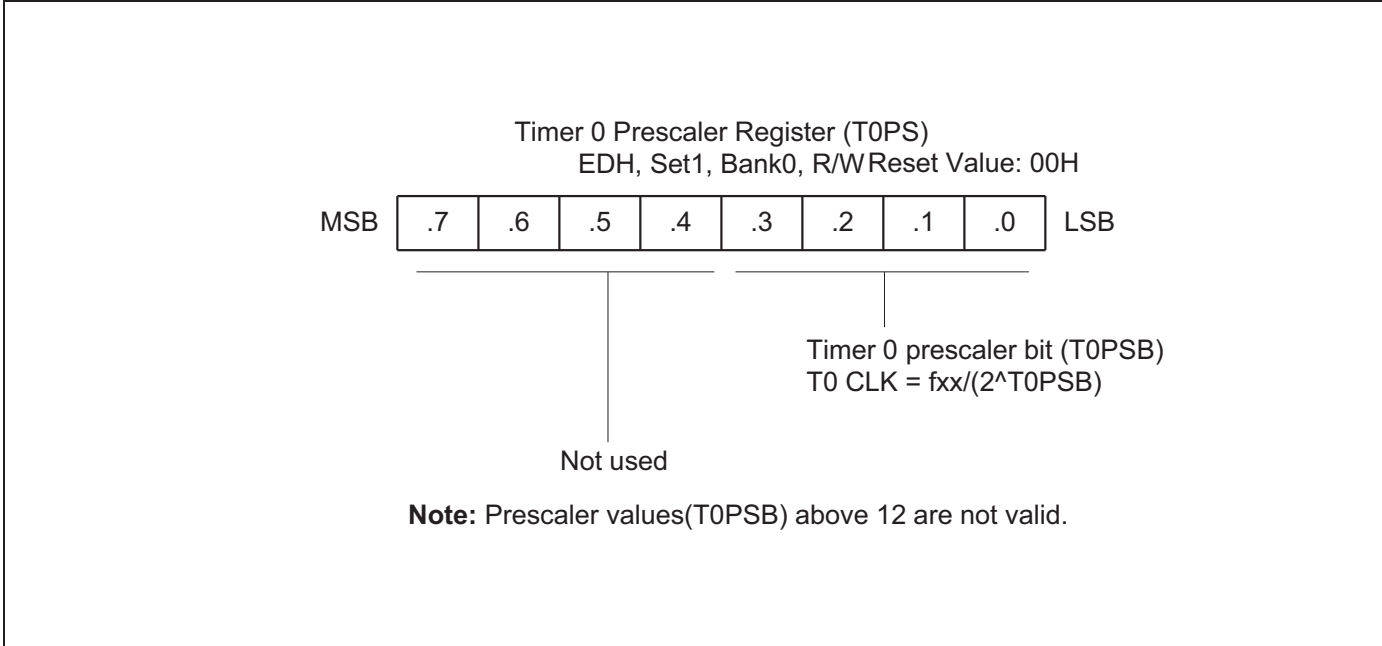


Figure 13-2 Timer 0 Pre-scalar Register (T0PS)

### 13.3 Block Diagram (Timer 0)

Figure 13-3 illustrates the functional block diagram of Timer 0.

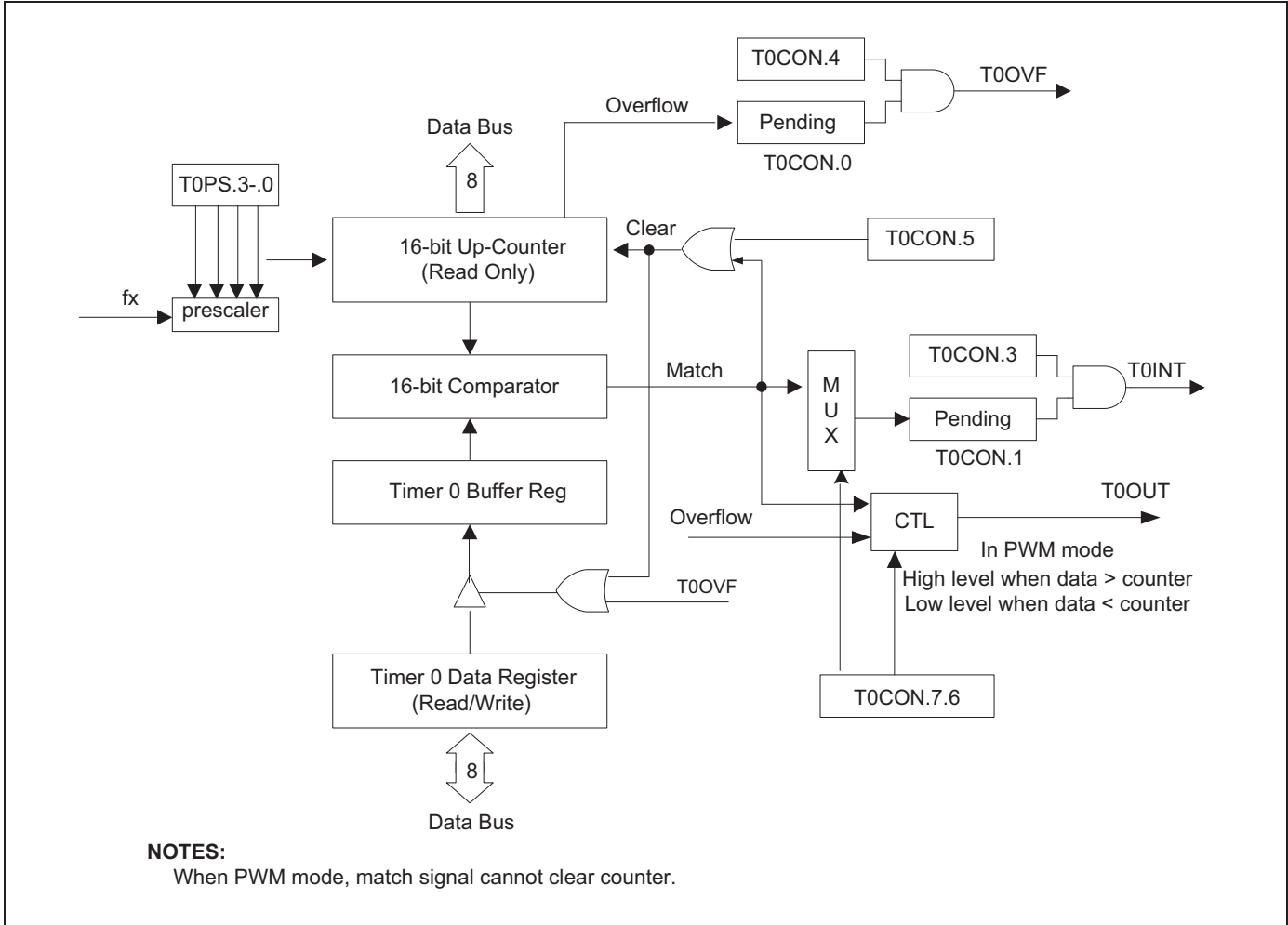


Figure 13-3 Timer 0 Functional Block Diagram

## 13.4 Overview of 16-Bit Timer 1

The 16-bit timer 1 is a 16-bit general-purpose timer.

Timer 1 has three operating modes:

- Interval timer mode (Toggle output at T1OUT pin)
- Capture input mode with a rising or falling edge trigger at the T1CAP pin
- PWM mode. PWM output shares their output port with T1OUT pin

You can select one of these modes can by using the appropriate T1CON setting:

The functional components of Timer 1 are:

- External clock input pin (T1CLK)
- Clock frequency divider with pre-scalar (T1PS)
- A 16-bit counter (T1CNTH/L), a 16-bit comparator, and two 16-bit reference data register (T1DATAH/L)
- I/O pins for capture input (T1CAP), or match output (T1OUT)
- Timer 1 overflow interrupt (IRQ3, vector DAH) and match/capture interrupt (IRQ3, vector D8H) generation
- Timer 1 control register, T1CON (set 1, Bank 0, F2H, read/write)



### 13.5 Timer 1 Control Register

You use the timer 1 control register, T1CON, to:

- Select the timer 1 operating mode (interval timer, capture mode, or PWM mode)
- Select the timer 1 input clock frequency (T1PS)
- Clear the timer 1 counter, T1CNTH/T1CNTL
- Enable the timer 1 overflow interrupt or timer 1 match/capture interrupt

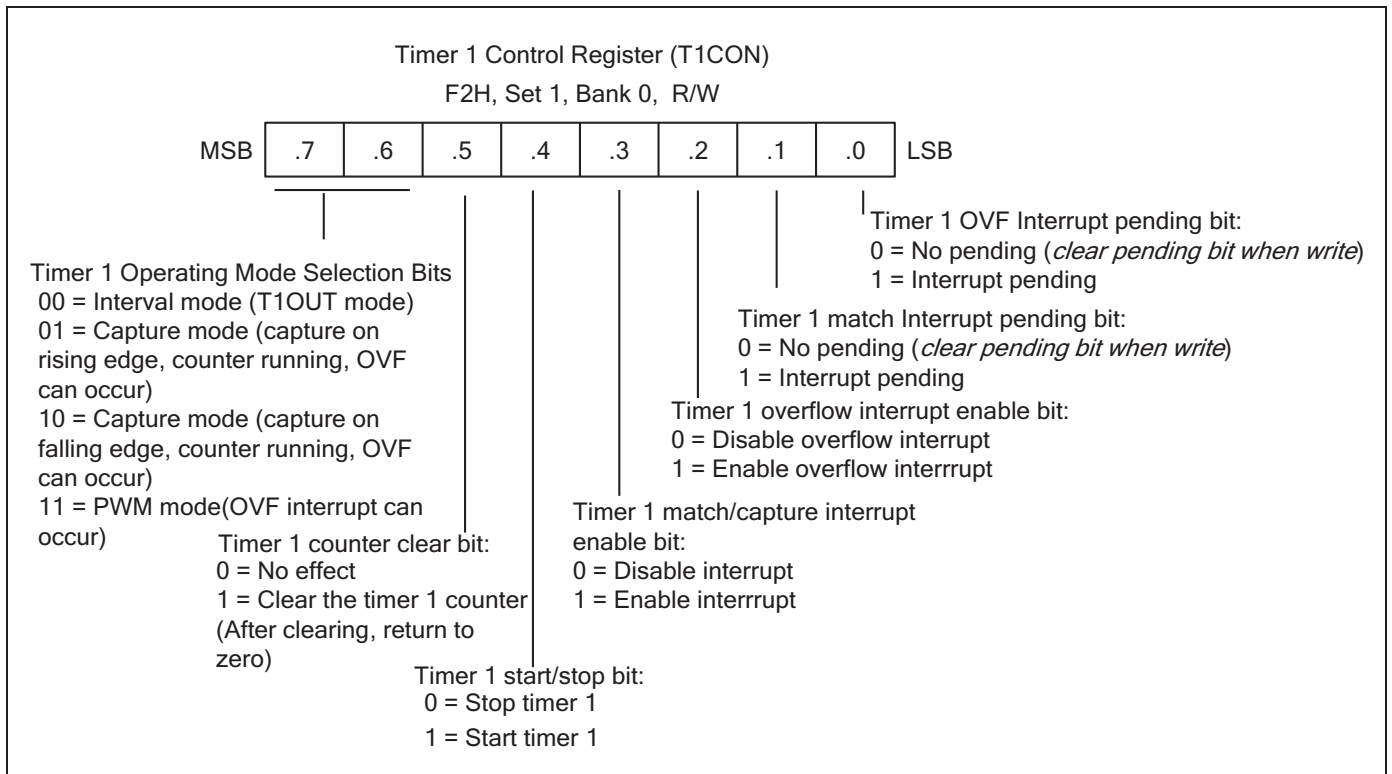
T1CON is located in set 1 and bank 0 at address F2H, and is read/write addressable that uses the Register addressing mode.

A reset clears T1CON to "00H". This sets timer 1 to normal interval timer mode. It selects an input clock frequency of f<sub>xx</sub>, and disables all timer 1 interrupts. To disable the counter operation, set T1CON.4 to "0". You can clear the timer 1 counter at any time during normal operation by writing a "1" to T1CON.5.

The timer 1 overflow interrupt (T1OVF) is interrupt level IRQ3 and has the vector address 0xDAH. When a timer 1 match/capture interrupt occurs and is serviced interrupt (IRQ3, vector DAH), you should write T1CON.1 to "0". When a timer 1 overflow interrupt occurs and is serviced by the CPU, the pending condition is cleared automatically by hardware or must be cleared by software.

To enable the timer 1 match/capture interrupt (IRQ3, vector D8H), you should write T1CON.3 to "1". To detect a match/capture interrupt pending condition, the application program polls T1CON.1. When a "1" is detected, a timer 1 match or capture interrupt is pending. When the interrupt request has been serviced, the pending condition must be cleared by software by writing a "0" to the timer 1 match/capture interrupt pending bit, T1CON.1.

[Figure 13-4](#) illustrates the Timer 1 control register.



**Figure 13-4 Timer 1 Control Register (T1CON)**

Figure 13-5 illustrates the Timer 1 pre-scalar register.

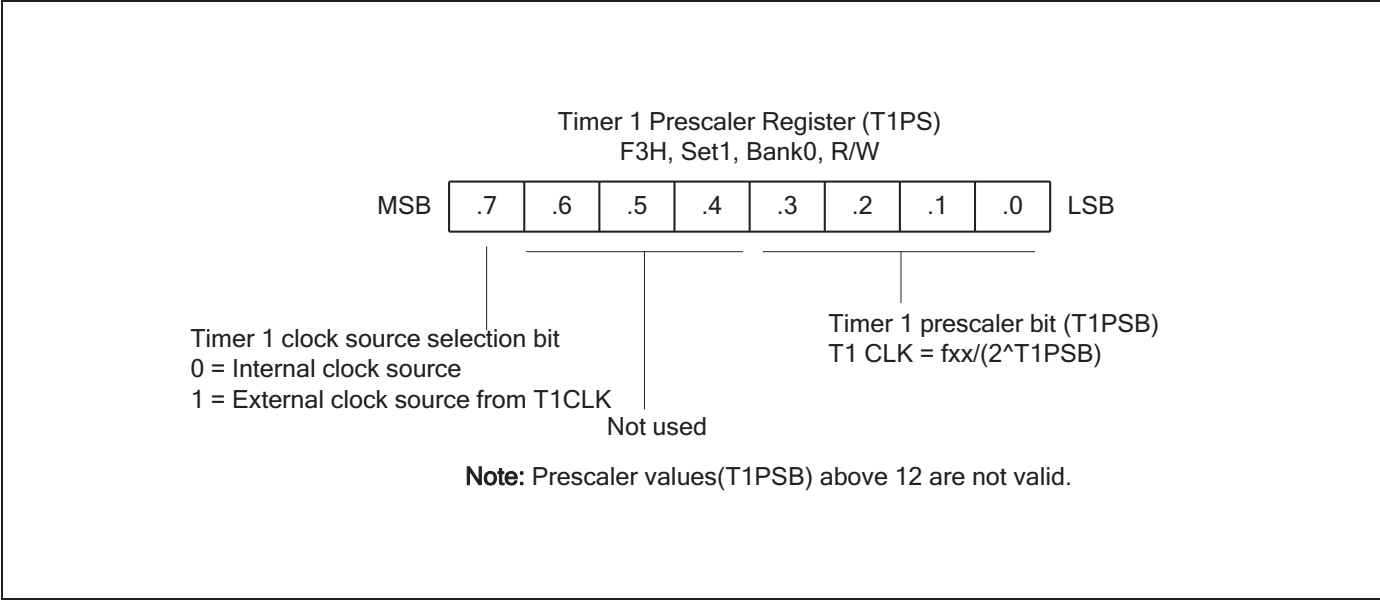


Figure 13-5 Timer 1 Pre-scalar Register (T1PS)

## 13.6 Timer 1 Function Description

This section includes:

- Timer 1 interrupts (IRQ3, Vectors D8H and DAH)
- Interval timer mode
- Pulse width modulation mode
- Capture mode

### 13.6.1 Timer 1 Interrupts (IRQ3, Vectors D8H and DAH)

Timer 1 generates two interrupts:

- Timer 1 overflow interrupt (T1OVF)
- Timer 1 match/capture interrupt (T1INT)

T1OVF belongs to interrupt level IRQ3, vector DAH. T1INT belongs to interrupt level IRQ3, but is assigned the separate vector address, D8H.

A timer 1 overflow interrupt pending condition is automatically cleared by hardware when it has been serviced or should be cleared by software in the interrupt service routine by writing a "0" to the T1CON.0. However, the timer 1 match/capture interrupt pending condition must be cleared by the application's interrupt service routine by writing a "0" to the T1CON.1.

### 13.6.2 Interval Timer Mode

In interval timer mode, a match signal is generated when the counter value is identical to the value written to the timer 1 reference data register, T1DATAH/T1DATAL. The match signal generates a timer 1 match interrupt (T1INT, vector D8H) and clears the counter.

If, for example, you write the value "1087H" to T1DATAH/T1DATAL, the counter will increment until it reaches "1087H". At this point, the timer 1 interrupt request is generated, resets the counter value, and resumes counting. With each match, the level of the signal at the timer 1 output pin is inverted.

### 13.6.3 Pulse Width Modulation Mode

PWM mode enables you to program the width (duration) of the pulse that is output at the T1OUT pin. As in interval timer mode, a match signal is generated when the counter value is identical to the value written to the timer 1 data register. However, in PWM mode, the match signal does not clear the counter. Instead, it runs continuously, overflowing at "FFFFH", and then continues to increment from "0000H".

Although you can use the match signal to generate a timer 1 overflow interrupt, interrupts are not typically used in PWM-type applications. Instead, the pulse at the T1PWM pin is held to Low level as long as the reference data value is less than or equal to ( $\leq$ ) the counter value. The pulse is held to High level for as long as the data value is greater than ( $>$ ) the counter value. One pulse width is equal to  $t_{CLK} \times 65536$ .

### 13.6.4 Capture Mode

In capture mode, a signal edge that is detected at the T1CAP pin, opens a gate, and loads the current counter value into the timer 1 data register. You can select rising or falling edges to trigger this operation.

Timer 1 also provides you with capture input source: The signal edge at the T1CAP pin. You can select the capture input by setting the values of the timer 1 capture input selection bits in the port 3 control register, P3CONH.7–.6 (set 1, bank 1, E8H). When P3CONH.7–.6 is "00", the T1CAP input is selected.

Both kinds of timer 1 interrupts can be used in capture mode: the timer 1 overflow interrupt is generated whenever a counter overflow occurs. The timer 1 match/capture interrupt is generated whenever the counter value is loaded into the timer 1 data register.

By reading the captured data value in T1DATAH/T1DATAL, and assuming a specific value for the timer 1 clock frequency, you can calculate the pulse width (duration) of the signal that is being input at the T1CAP pin.

### 13.7 Block Diagram (Timer 1)

Figure 13-6 illustrates the functional block diagram of Timer 1.

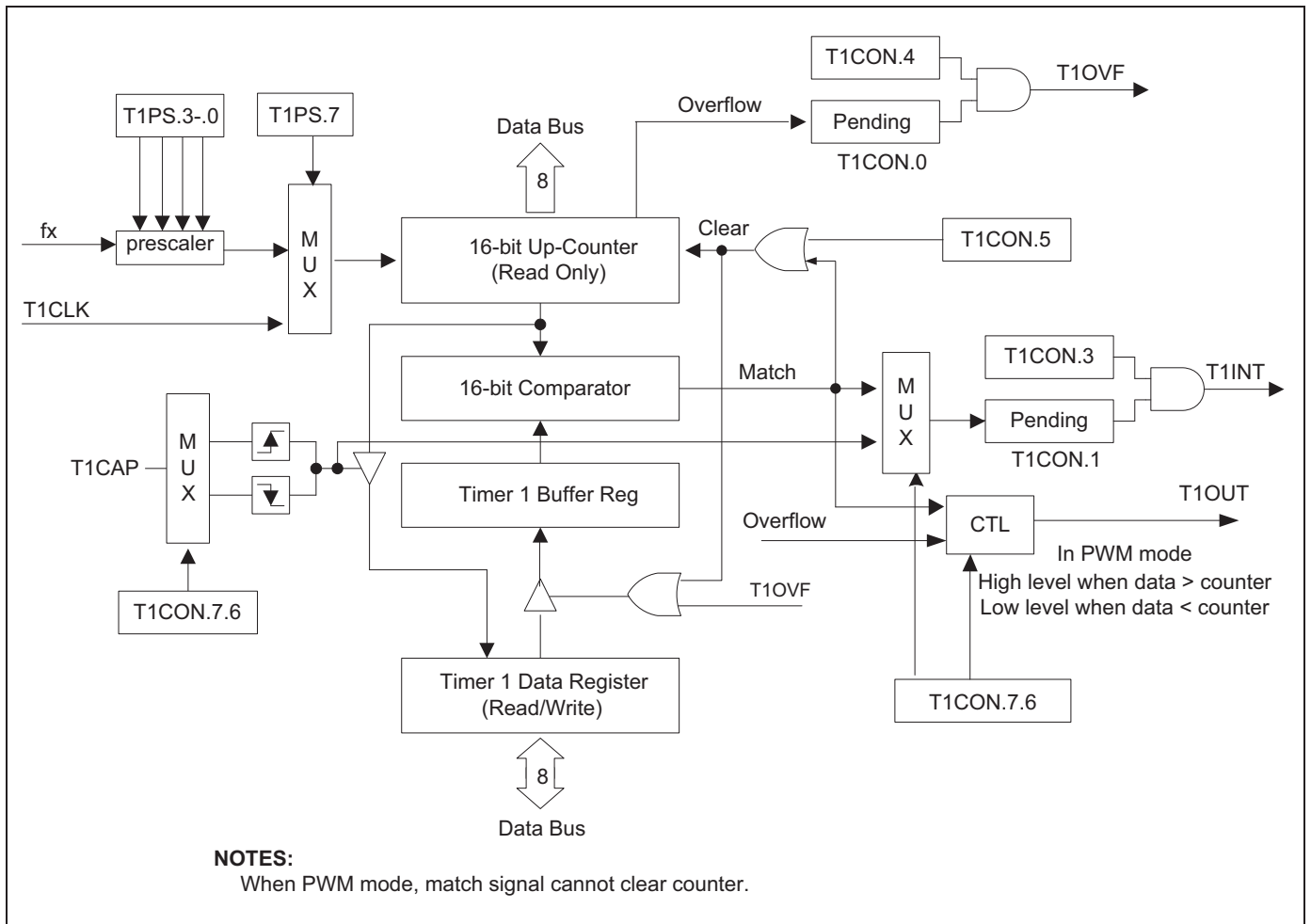


Figure 13-6 Timer 1 Functional Block Diagram

## 13.8 Overview of 16-Bit Timer 2

The 16-bit timer 2 is a 16-bit general-purpose timer.

Timer 2 has three operating modes:

- Interval timer mode (Toggle output at T2OUT pin)
- Capture input mode with a rising or falling edge trigger at the T2CAP pin
- PWM mode (T2PWM): PWM output shares their output port with T2OUT pin

You can select of these modes by using the appropriate T2CON setting:

The functional components Timer 2 are:

- Clock frequency divider with pre-scalar(T2PS)
- External clock input pin (T2CLK)
- A 16-bit counter (T2CNTH/L), a 16-bit comparator, and two 16-bit reference data register (T2DATAH/L)
- I/O pins for capture input (T2CAP), or match output (T2OUT)
- Timer 2 overflow interrupt (IRQ3, vector DEH) and match/capture interrupt (IRQ3, vector DCH) generation
- Timer 2 control register, T2CON (set 1, Bank 1, F8H, read/write)

### 13.9 Timer 2 Control Register

You use the timer 2 control register, T2CON, to:

- Select the timer 2 operating mode (interval timer, capture mode, or PWM mode)
- Select the timer 2 input clock frequency (T2PS)
- Clear the timer 2 counter, T2CNTH/T 2CNTL
- Enable the timer 2 overflow interrupt or timer 2 match/capture interrupt

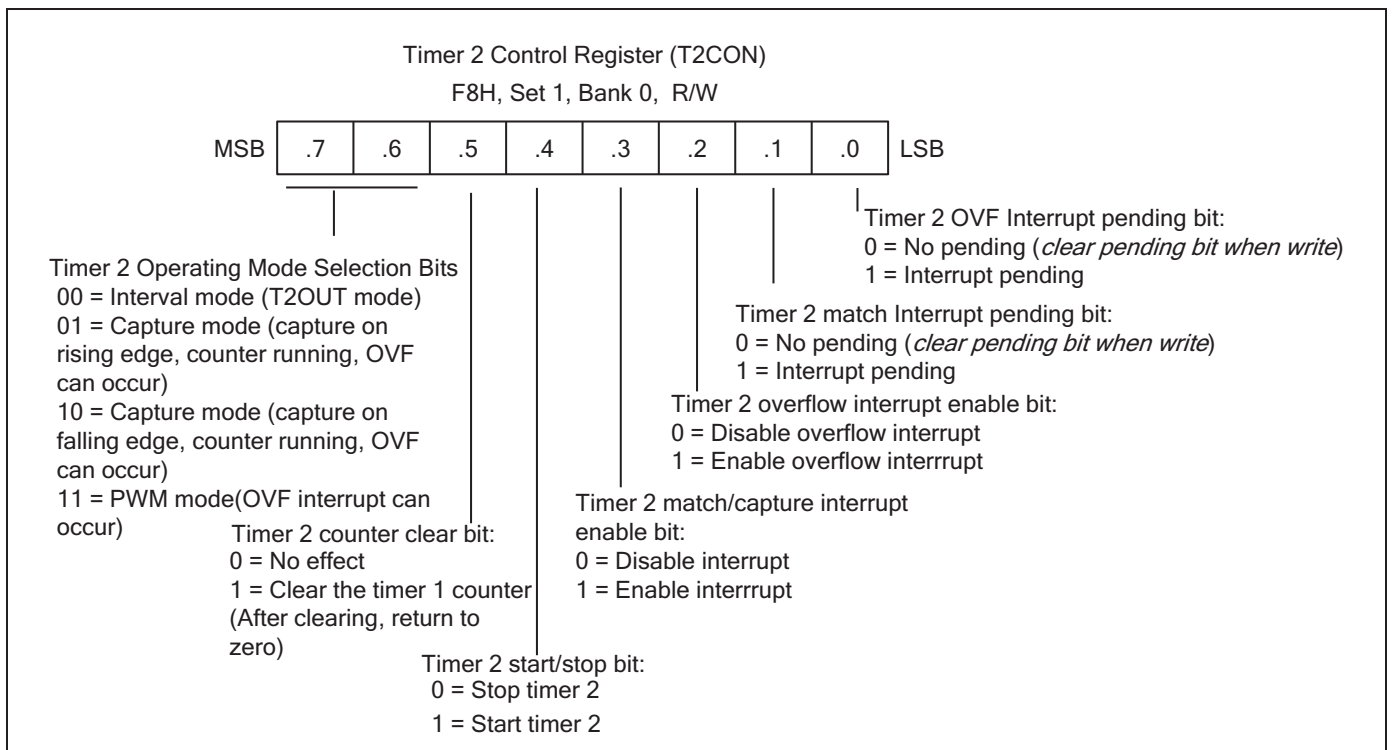
T2CON is located in set 1 and bank 1 at address F8H, and is read/write addressable that uses Register addressing mode.

A reset clears T2CON to '00H'. This sets timer 1 to normal interval timer mode, selects an input clock frequency of f<sub>xx</sub>, and disables all timer 2 interrupts. To disable the counter operation, set T2CON.4 to "0". You can clear the timer 2 counter at any time during normal operation by writing a "1" to T2CON.5.

The timer 2 overflow interrupt (T2OVF) is interrupt level IRQ3 and has the vector address 0xDEH. When a timer 2 match/capture interrupt occurs and is serviced interrupt (IRQ3, vector DEH), you should write T2CON.1 to "0". When a timer 2 overflow interrupt occurs and is serviced by the CPU, the pending condition is cleared automatically by hardware or must be cleared by software.

To enable the timer 2 match/capture interrupt (IRQ3, vector DCH), you should write T2CON.3 to "1". To detect a match/capture interrupt pending condition, the application program polls T2CON.1. When a "1" is detected, a timer 2 match/capture interrupt is pending. When the interrupt request has been serviced, the pending condition must be cleared by software by writing a "0" to the timer 2 match/capture interrupt pending bit, T2CON.1.

[Figure 13-7](#) illustrates the Timer 2 control register.



**Figure 13-7 Timer 2 Control Register (T2CON)**

Figure 13-8 illustrates the Timer 2 pre-scalar register.

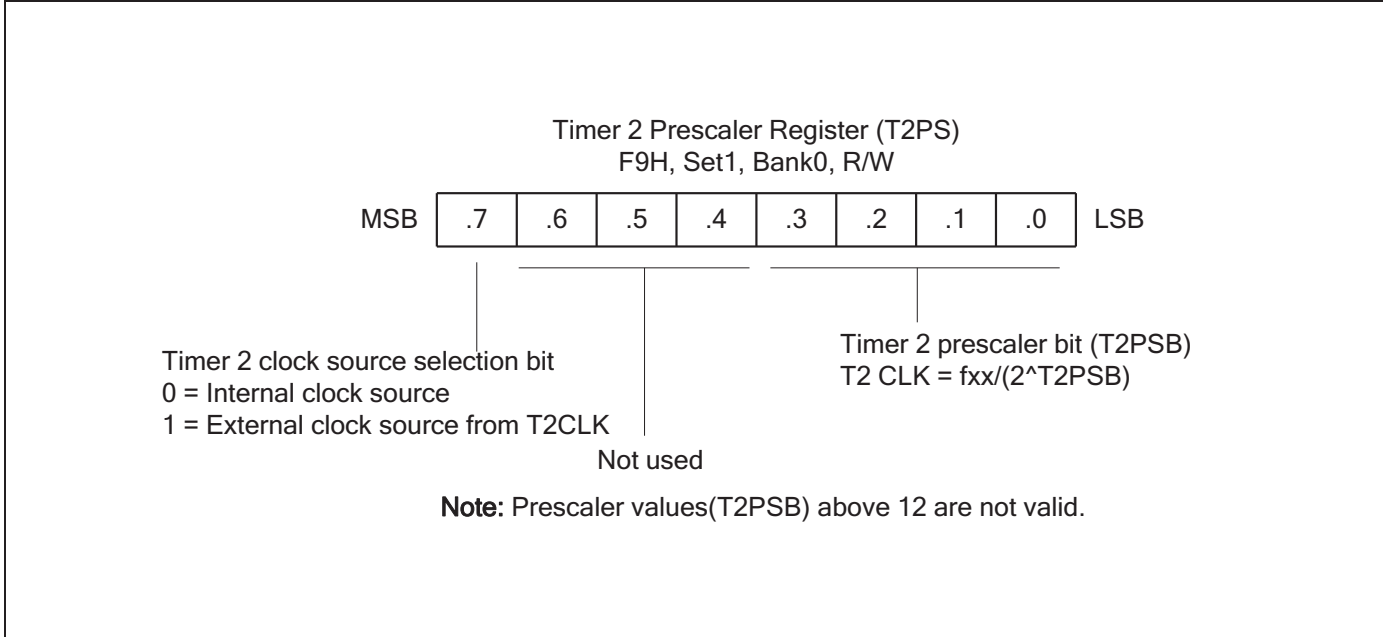


Figure 13-8 Timer 2 Pre-Scalar Register (T2PS)



## 13.10 Timer 2 Function Description

This section includes:

- Timer 2 interrupts (IRQ3, Vectors DCH and DEH)
- Interval timer mode
- Pulse width modulation mode
- Capture mode

### 13.10.1 Timer 2 Interrupts (IRQ3, Vectors DCH and DEH)

Timer 2 generates two interrupts:

- Timer 2 overflow interrupt (T2OVF)
- Timer 2 match/capture interrupt (T2INT)

T2OVF belongs to interrupt level IRQ3, vector DEH. T2INT also belongs to interrupt level IRQ3, but is assigned the separate vector address, DCH.

A timer 2 overflow interrupt pending condition is automatically cleared by hardware when it has been serviced or should be cleared by software in the interrupt service routine by writing a "0" to the T2CON.0. However, the timer 2 match/capture interrupt pending condition must be cleared by the application's interrupt service routine by writing a "0" to the T2CON.1.

### 13.10.2 Interval Timer Mode

In interval timer mode, a match signal is generated when the counter value is identical to the value written to the timer 2 reference data register, T2DATAH/T2DATAL. The match signal generates a timer 2 match interrupt (T2INT, vector DCH) and clears the counter.

If, for example, you write the value "1087H" to T2DATAH/T2DATAL, the counter increments until it reaches "1087H". At this point, the timer 2 interrupt request is generated, resets the counter value, and resumes counting. With each match, the level of the signal at the timer 2 output pin is inverted.

### 13.10.3 Pulse Width Modulation Mode

PWM mode enables you to program the width (duration) of the pulse that is output at the T2OUT pin. As in interval timer mode, a match signal is generated when the counter value is identical to the value written to the timer 2 data register. However, in PWM mode, the match signal does not clear the counter. Instead, it runs continuously, overflowing at "FFFFH", and then continues to increment from "0000H".

Although you can use the match signal to generate a timer 2 overflow interrupt, interrupts are not typically used in PWM-type applications. Instead, the pulse at the T2OUT pin is held to Low level as long as the reference data value is less than or equal to ( $\leq$ ) the counter value. Then the pulse is held to High level for as long as the data value is greater than ( $>$ ) the counter value. One pulse width is equal to  $t_{CLK} \times 65536$ .

#### 13.10.4 Capture Mode

In capture mode, a signal edge that is detected at the T2CAP pin opens a gate and loads the current counter value into the timer 2 data register. You can select rising or falling edges to trigger this operation.

Timer 2 also provides you with capture input source: The signal edge at the T2CAP pin. You can select the capture input by setting the values of the timer 2 capture input selection bits in the port 3 control register, P3CONH.3–.2 (set 1, bank 1, E4H). When P3CONH.3–.2 is "00", the T2CAP input is selected.

Both kinds of timer 2 interrupts can be used in capture mode: the timer 2 overflow interrupt is generated whenever a counter overflow occurs. The timer 2 match/capture interrupt is generated whenever the counter value is loaded into the timer 2 data register.

By reading the captured data value in T2DATAH/T2DATAL, and assuming a specific value for the timer 2 clock frequency, you can calculate the pulse width (duration) of the signal that is being input at the T2CAP pin.

13.11 Block Diagram (Timer 2)

Figure 13-9 illustrates the functional block diagram of Timer 2.

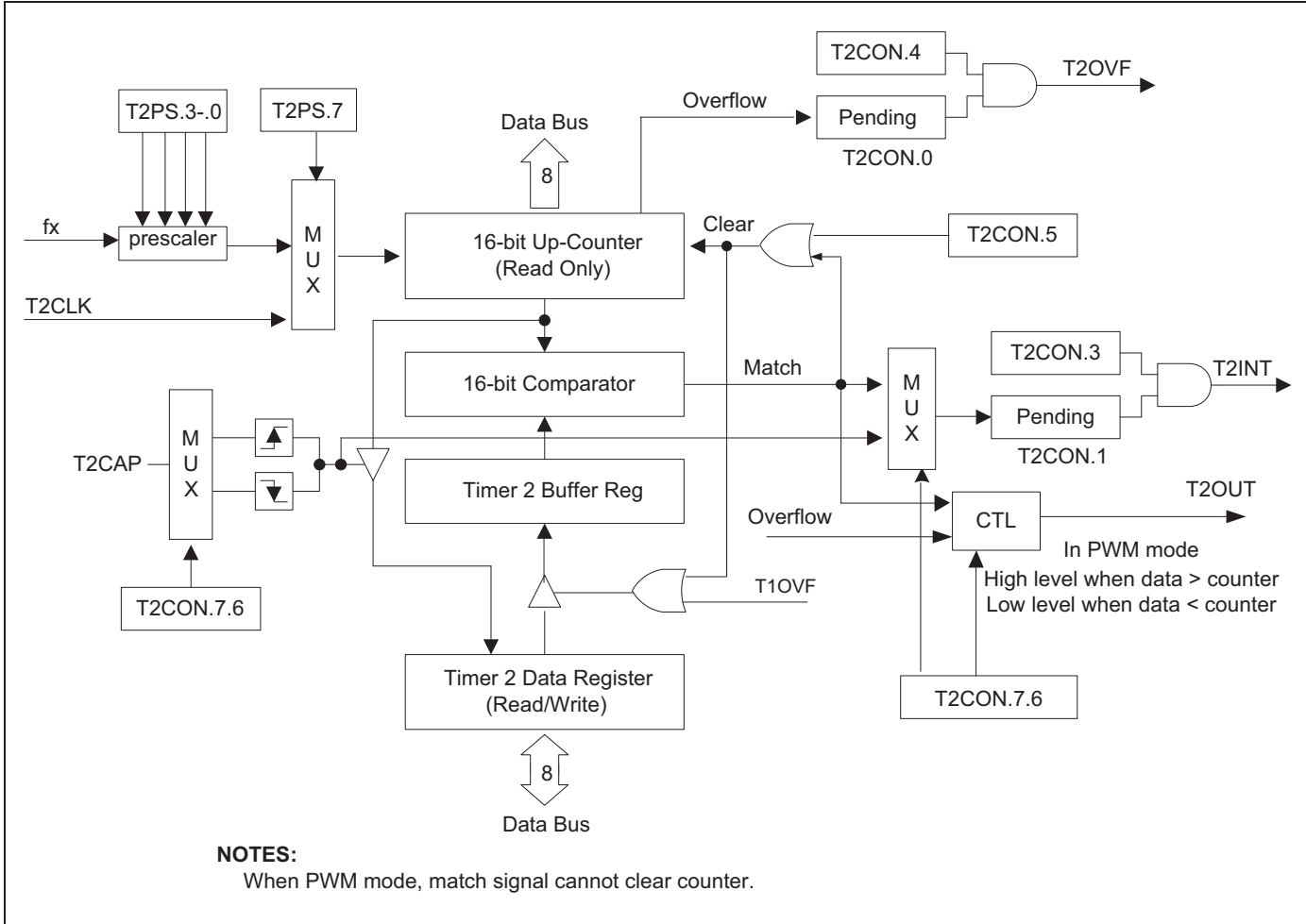


Figure 13-9 Timer 2 Functional Block Diagram

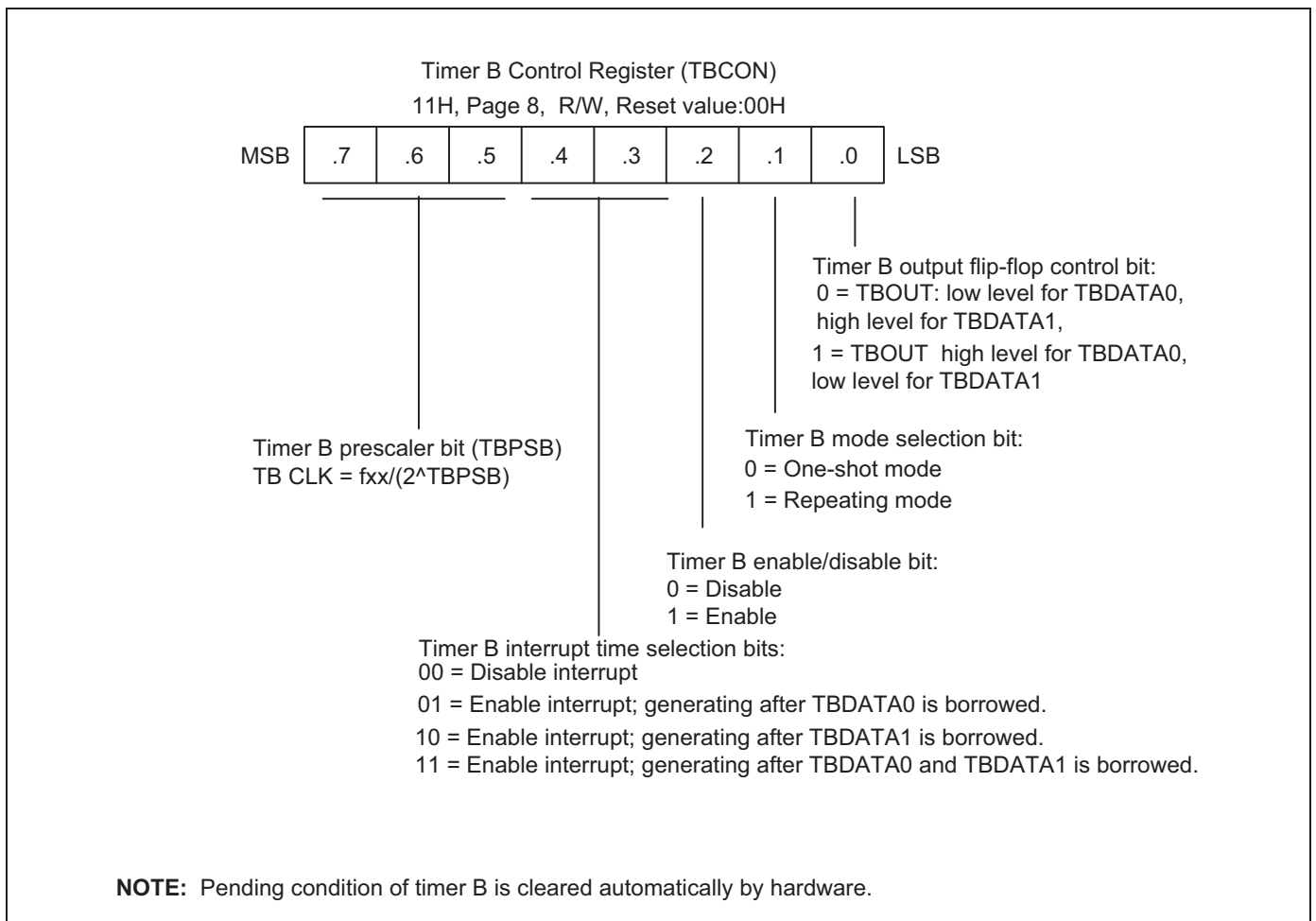
### 13.12 Overview of 16-Bit Timer B

The S3F8S19/F8S15 micro-controller has a 16-bit counter called timer B, which you can use to generate the carrier frequency of a remote controller signal.

Timer B has four functions:

- As a normal interval timer, generating a timer B interrupt at programmed time intervals.
- To generate a programmable carrier pulse for a remote control signal at TBOU.T.
- To generate one shot pulse triggered by external input signal or software.
- Emergency detection by external input trigger and stop PWM output automatically.

[Figure 13-10](#) illustrates the Timer B control register.



**Figure 13-10 Timer B Control Register**

Figure 13-11 illustrates the Timer B trigger register.

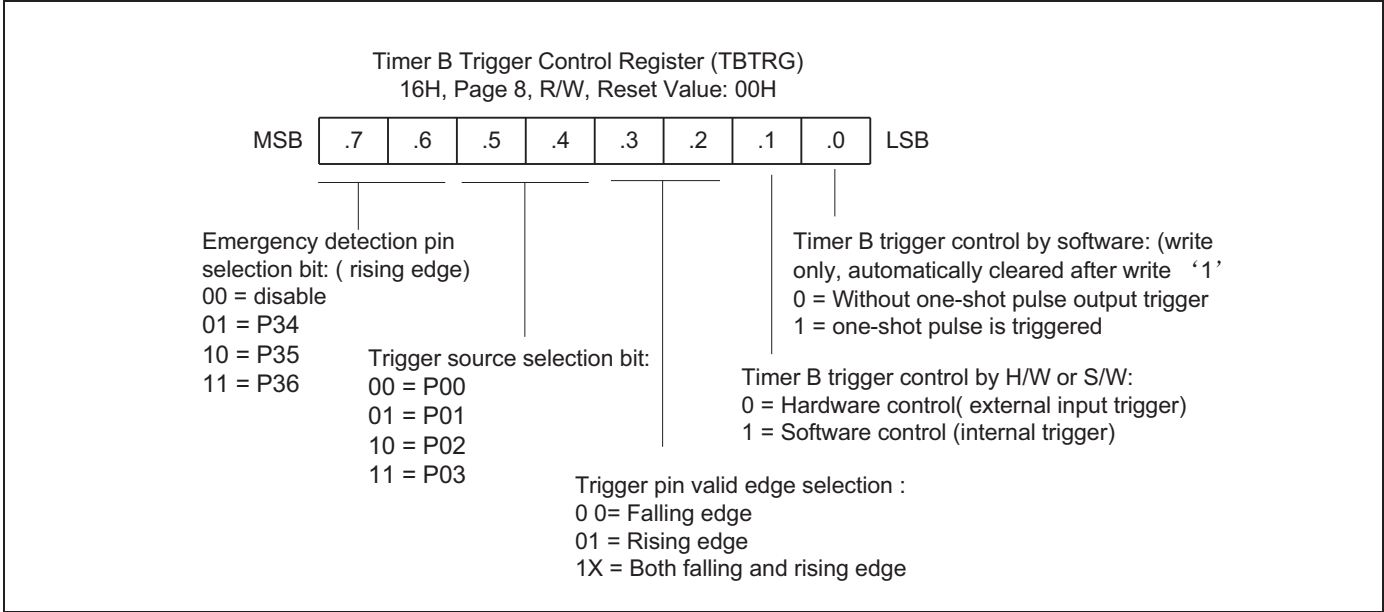


Figure 13-11 Timer B Trigger Register (TBTRG)

Figure 13-12 illustrates the Timer B data registers (TBDATA0H/L).

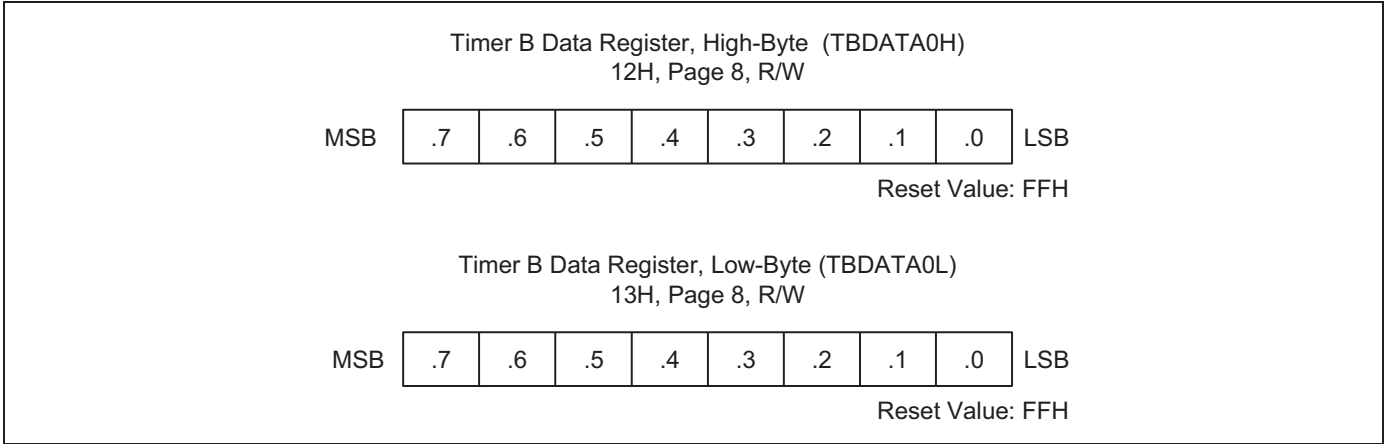


Figure 13-12 Timer B Data Registers (TBDATA0H/L)

Figure 13-13 illustrates the Timer B data registers (TBDATA1H/L).

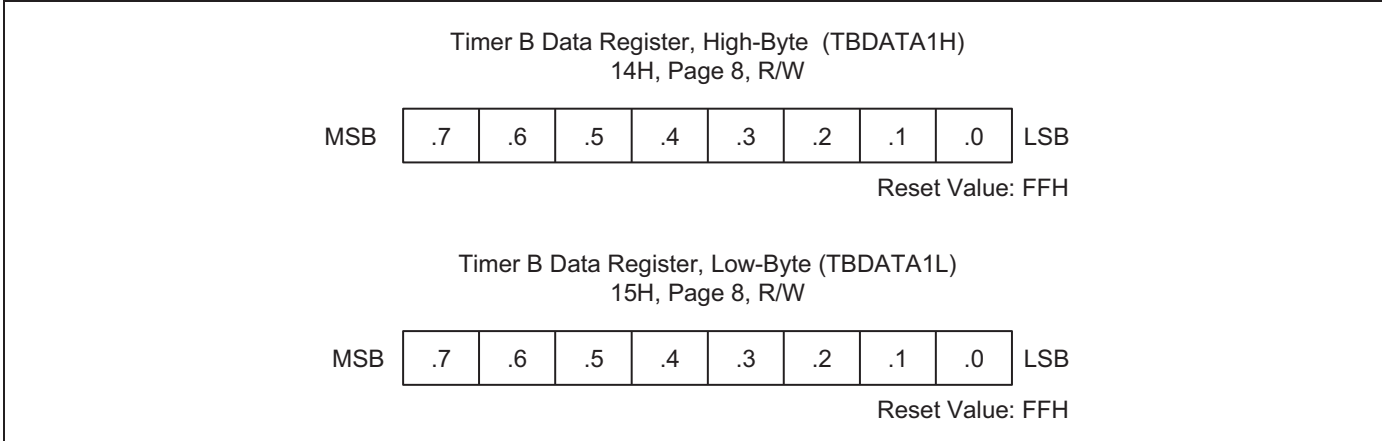


Figure 13-13 Timer B Data Registers (TBDATA1H/L)

### 13.13 Block Diagram (Timer B)

Figure 13-14 illustrates the functional block diagram of Timer B.

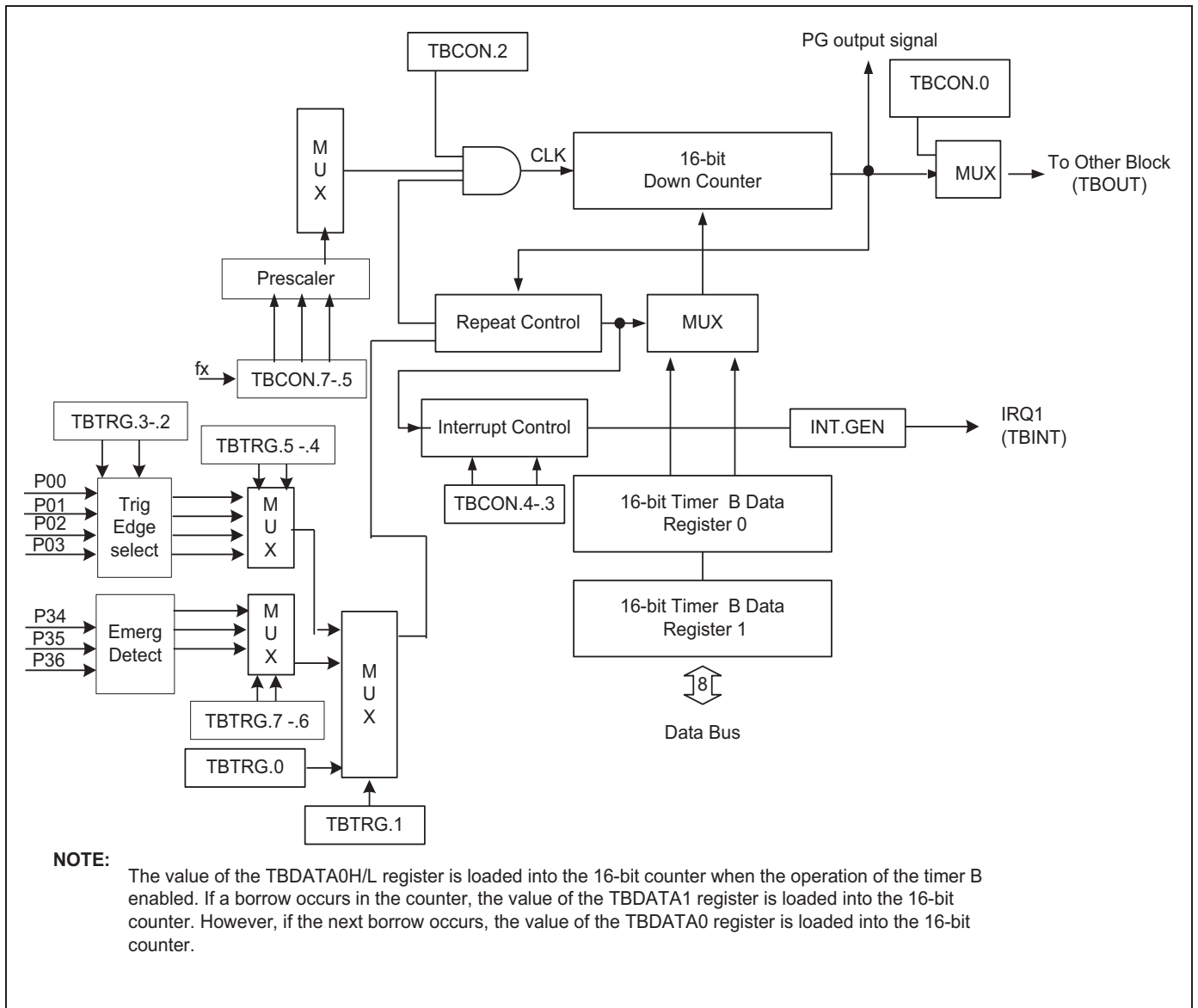
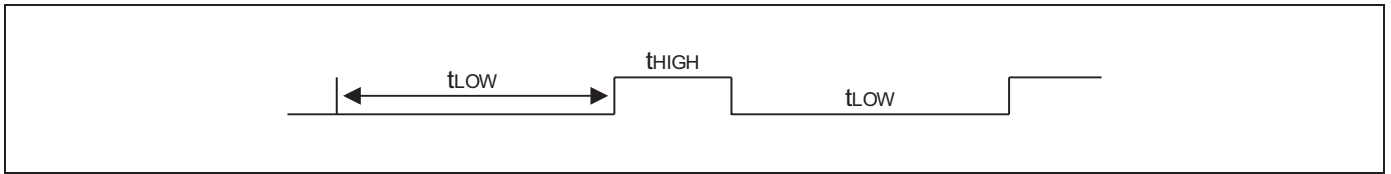


Figure 13-14 Timer B Functional Block Diagram

### 13.13.1 Timer B Pulse Width Calculations



To generate the above repeated waveform consisted of low period time,  $t_{LOW}$ , and high period time,  $t_{HIGH}$ :

When TBOF = 0,

$$t_{LOW} = (TBDATA0 + 2) \times 1/f_x, 0H < TBDATA0 < 10000H, \text{ where } f_x = \text{the selected clock.}$$

$$t_{HIGH} = (TBDATA1 + 2) \times 1/f_x, 0H < TBDATA1 < 10000H, \text{ where } f_x = \text{the selected clock.}$$

When TBOF = 1,

$$t_{LOW} = (TBDATA1 + 2) \times 1/f_x, 0H < TBDATA1 < 10000H, \text{ where } f_x = \text{the selected clock.}$$

$$t_{HIGH} = (TBDATA0 + 2) \times 1/f_x, 0H < TBDATA0 < 10000H, \text{ where } f_x = \text{the selected clock.}$$

To make  $t_{LOW} = 24 \mu\text{s}$  and  $t_{HIGH} = 15 \mu\text{s}$ .  $f_{OSC} = 4 \text{ MHz}$ ,  $f_x = 4 \text{ MHz}/4 = 1 \text{ MHz}$ :

When TBOF = 0,

$$t_{LOW} = 24 \mu\text{s} = (TBDATA0 + 2)/f_x = (TBDATA0 + 2) \times 1 \mu\text{s}, TBDATA0 = 22.$$

$$t_{HIGH} = 15 \mu\text{s} = (TBDATA1 + 2)/f_x = (TBDATA1 + 2) \times 1 \mu\text{s}, TBDATA1 = 13.$$

When TBOF = 1,

$$t_{HIGH} = 15 \mu\text{s} = (TBDATA0 + 2)/f_x = (TBDATA0 + 2) \times 1 \mu\text{s}, TBDATA0 = 13.$$

$$t_{LOW} = 24 \mu\text{s} = (TBDATA1 + 2)/f_x = (TBDATA1 + 2) \times 1 \mu\text{s}, TBDATA1 = 22.$$



Figure 13-15 illustrates the Timer B output flip-flop waveforms in repeat mode.

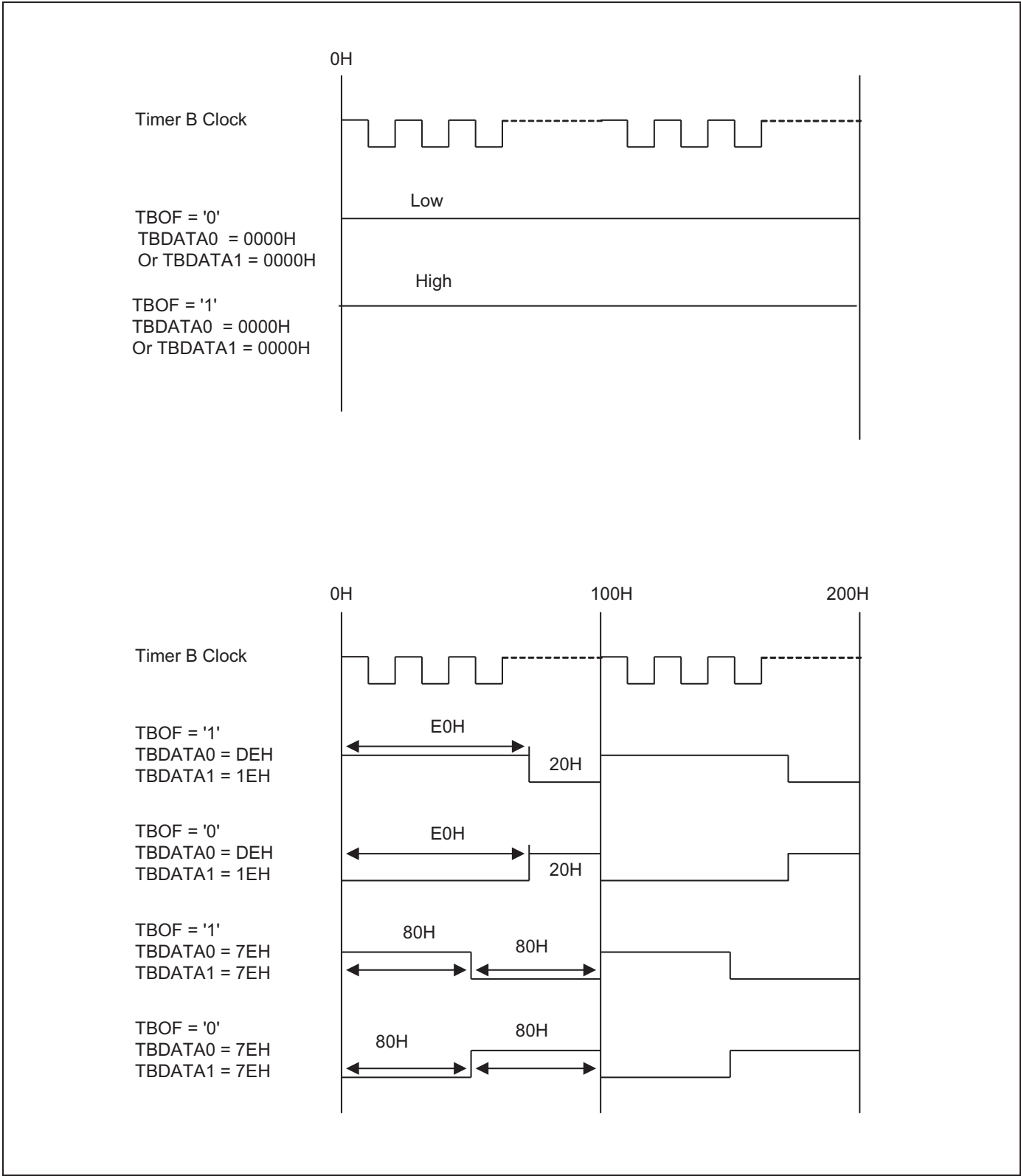
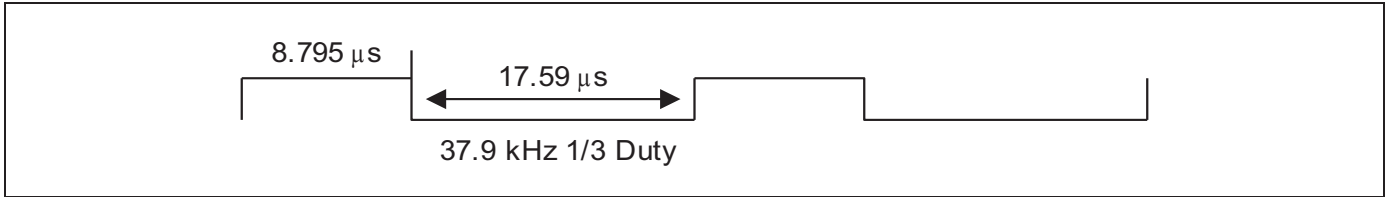


Figure 13-15 Timer B Output Flip-Flop Waveforms in Repeat Mode

[Example 13-1](#) sets Timer B to the repeat mode. It sets the oscillation frequency as the Timer B clock source, and TBDATA0 and TBDATA1 to make a 38 kHz, 1/3 Duty carrier frequency.

**Example 13-1 To Generate 38 kHz, 1/3 Duty Signal through P2.1**



The program parameters are:

- Timer B is used in repeat mode
- Oscillation frequency is 4 MHz (0.25 μs)
- TBDATA0 = 17.59 μs/0.25 μs = 70.36, TBDATA1 = 8.795 μs/0.25 μs = 35.18
- Set P2.1 to TBOUT mode.

```

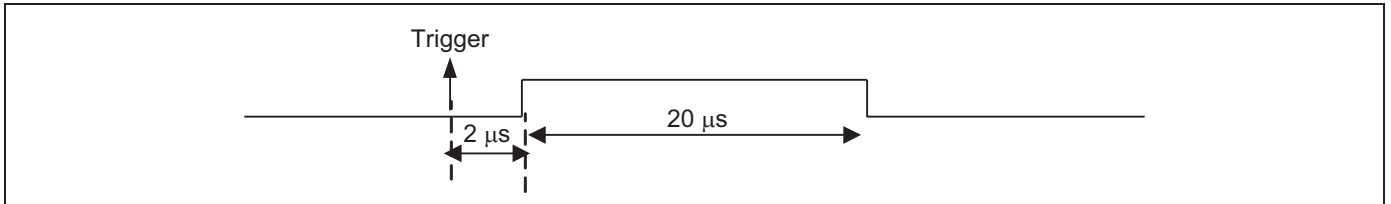
START      ORG      0100H          ;      Reset address
           DI
           .
           .
           .
           LD      TBDATA0H, #0      ;      Set 17.5 μs
           LD      TBDATA0L, # (70-2)
           LD      TBDATA1H, #0      ;      Set 8.75 μs
           LD      TBDATA1, # (35-2)
           LD      TBCON, #00000111B ;      Clock Source ← fxx
           LD      TBTRG, #0         ;      Disable Timer B interrupt.
                                           ;      Select repeat mode for Timer B.
                                           ;      Start Timer B operation.
                                           ;      Set Timer B Output flip-flop (TBOF) high.
           SB1
           OR      P4CONL, #00000100B ;      Set P4.1 to TBOUT mode.
           SB0      ;      this command generates 38 kHz, 1/3 duty pulse
                                           ;      signal through P4.1.
           .
           .
           .

```

[Example 13-2](#) sets Timer B to the one shot mode. It sets the oscillation frequency as the Timer B clock source, and TBDATA1 and TBDATA0 to make a 40  $\mu$ s width pulse.

### Example 13-2 To generate a one pulse signal through P2.1

This example sets Timer B to the one shot mode. It sets the oscillation frequency as the Timer B clock source, and TBDATA1 and TBDATA0 to make a 40  $\mu$ s width pulse. The program parameters are:



Here are the program parameters:

- Timer B is used in one shot mode
- Oscillation frequency is 4 MHz (1 clock = 0.25  $\mu$ s)
- Delay time from trigger detection is 2  $\mu$ s
- TBDATA1 = 20  $\mu$ s/0.25  $\mu$ s = 80, TBDATA0 = 2  $\mu$ s/0.25 = 8
- Set P2.1 to TBPWM mode

```

START      ORG      0100H          ;      Reset address
           DI
           .
           .
           .
           LD      TBDATA1H, # 0      ;      Set 20  $\mu$ s
           LD      TBDATA1L, # (80-2)
           LD      TBDATA0H, # 0      ;      Set 2  $\mu$ s
           LD      TBDATA0L, # (8-2)
           LD      TBCON, #00000101B ;      Clock Source  $\leftarrow$  fosc
                                           ;      Disable Timer B interrupt.
                                           ;      Select one shot mode for Timer B.
                                           ;      Enable Timer B operation.
           SB1     ;      Set Timer B output flip-flop (TBOF) high
           OR      P4CONL, #00000100B ;      Set P4.1 to TBOUT mode.
           SB0
Pulse_out: LD      TBTRG, #0000010B   ;      Set valid trigger source P0.0 falling edge.
                                           ;      Trigger by software.
           .
           .

```

# 14

## Watch Timer

### 14.1 Overview

Watch timer functions include real-time and watch-time measurements and interval timing for the system clock.

To start watch timer operation, set bit 1 of the watch timer control register, WTCON.1 to "1". If you want to service watch timer overflow interrupt (IRQ4, vector E2H), then set the WTCON.6 to "1". The watch timer overflow interrupt pending condition (WTCON.0) must be cleared by software in the application's interrupt service routine by writing a "0" to the WTCON.0 interrupt pending bit. After the watch timer starts and elapses a time, the watch timer interrupt pending bit (WTCON.0) is automatically set to "1". Interrupt requests commence in 1.995 ms, 0.125, 0.25, and 0.5-second intervals by setting watch timer speed selection bits (WTCON.3–.2).

The watch timer can generate a steady 0.5 kHz, 1 kHz, 2 kHz, or 4 kHz signal to BUZ output pin for Buzzer. By setting WTCON.3 and WTCON.2 to "11b", the watch timer functions in high-speed mode by generating an interrupt every 1.995 ms. High-speed mode is useful for timing events for program debugging sequences.

The watch timer supplies the clock frequency for the LCD controller ( $f_{LCD}$ ). Therefore, if the watch timer is disabled, the LCD controller does not operate.

The components of watch timer are:

- Real Time and Watch-Time Measurement
- Uses a Main Clock Source or Sub clock
- Clock Source Generation for LCD Controller ( $f_{LCD}$ )
- I/O pin for Buzzer Output Frequency Generator (BUZ)
- Timing Tests in High-Speed Mode
- Watch timer overflow interrupt (IRQ4, vector E2H) generation
- Watch timer control register, WTCON (set 1, bank 0, FAH, Read/Write)

### 14.1.1 Watch Timer Control Register

It uses watch timer control register (WTCON) to:

Select the watch timer interrupt time and Buzzer signal

Enable or disable the watch timer function

WTCON is located in set 1, bank 0 at address FAH, and is Read/Write addressable by using register addressing mode.

A reset clears WTCON to "00H". This disables the watch timer.

Therefore, if you want to use the watch timer, you should write appropriate value to WTCON.

[Figure 14-1](#) illustrates the watch timer control register.

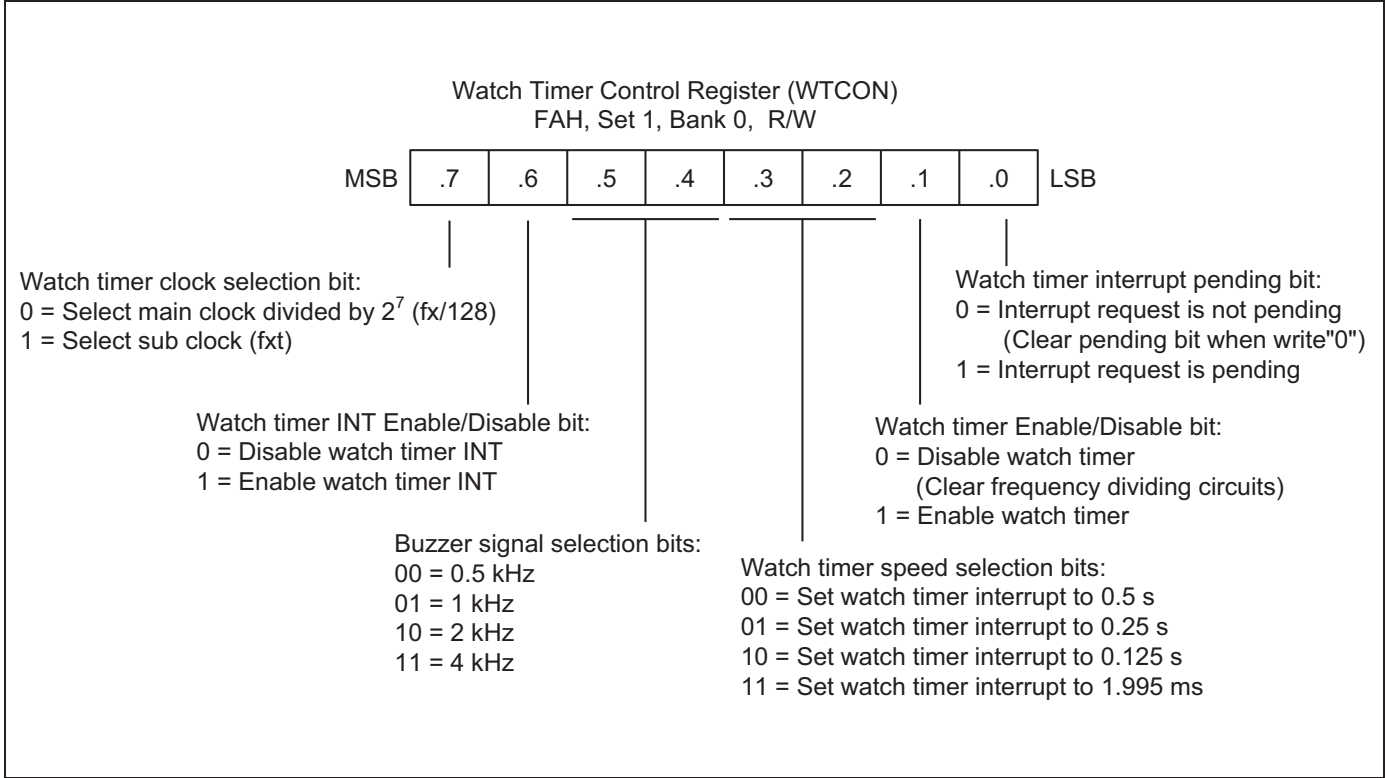


Figure 14-1 Watch Timer Control Register (WTCON)

14.1.2 Watch Timer Circuit Diagram

Figure 14-2 illustrates the circuit diagram of watch timer.

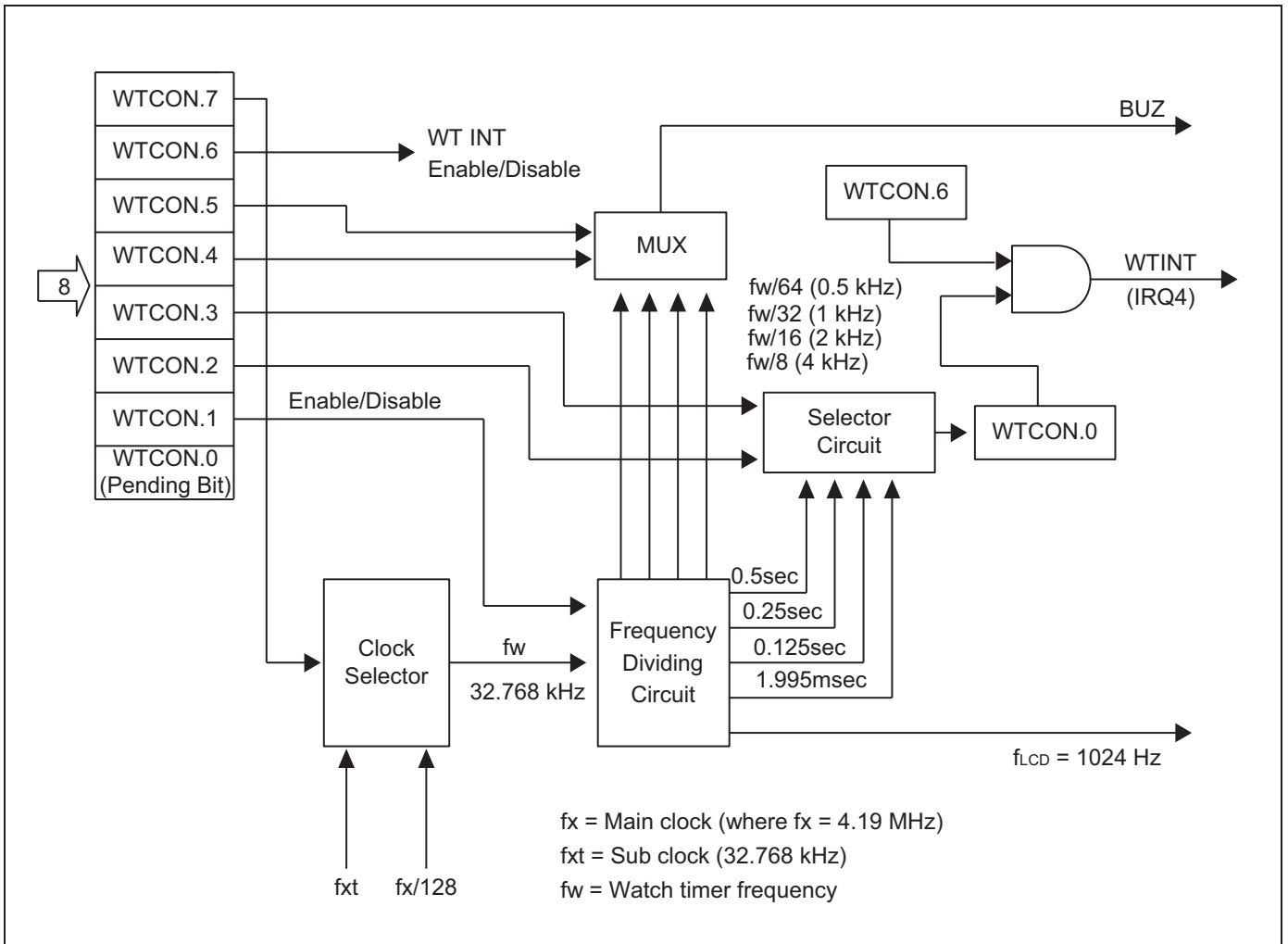


Figure 14-2 Watch Timer Circuit Diagram

# 15

## LCD Controller/Driver

### 15.1 Overview

The S3F8S19/F8S15 microcontroller can directly drive an up-to-128-dot (16 segments × 8 commons) LCD panel.

The components of LCD block are:

- LCD controller/driver
- Display Random Access Memory (RAM) (30H–45H) for storing display data in page 8
- Six common/segment output pins (COM2/SEG0–COM7/SEG5)
- Sixteen segment output pins (SEG6–SEG21)
- Two common output pins (COM0–COM1)
- Four LCD operating power supply pins (VLC0–VLC3)
- LCD bias by voltage booster
- LCD bias by voltage dividing resistors

The LCD control register, LCON, is used to turn the LCD display on and off; selects frame frequency, LCD duty and bias, and LCD bias type. The LCD mode control register, LMOD, is used to select VLCD voltage. Data written to the LCD display RAM can be automatically transferred to the segment signal pins without any program control. When a subsystem clock is selected as the LCD clock source, the LCD display is enabled even in the main clock stop or idle modes.

LCD data stored in the display RAM locations are transferred to the segment signal pins automatically without program control.

Figure 15-1 illustrates the LCD function diagram.

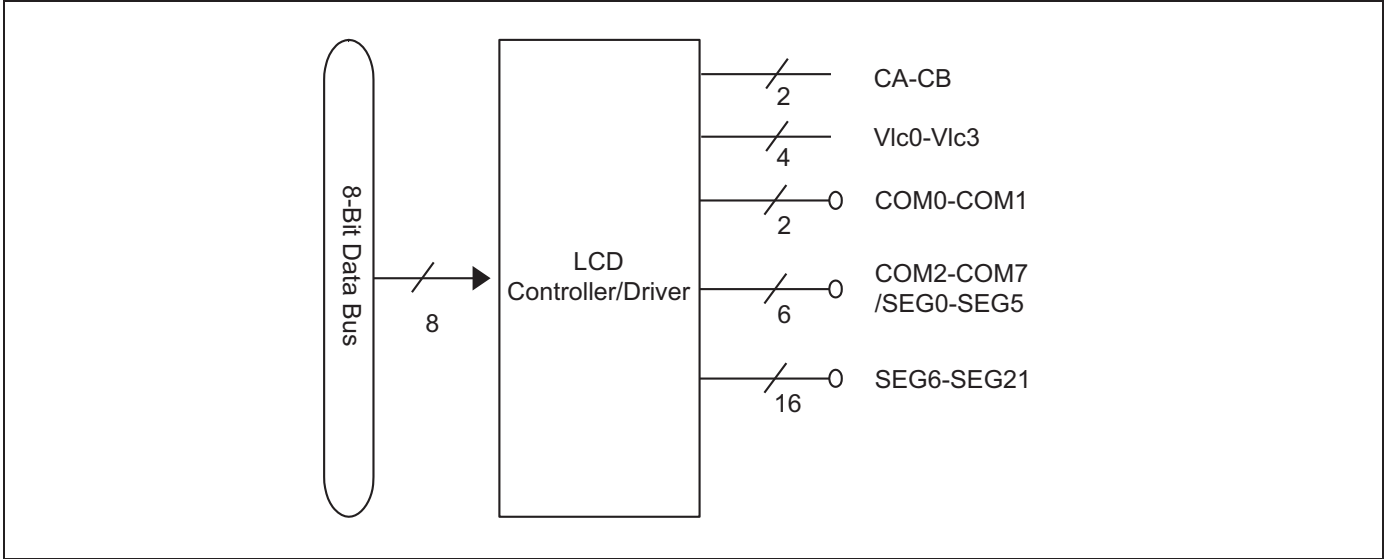


Figure 15-1 LCD Function Diagram



### 15.2 LCD Circuit Diagram

Figure 15-2 illustrates the LCD circuit diagram.

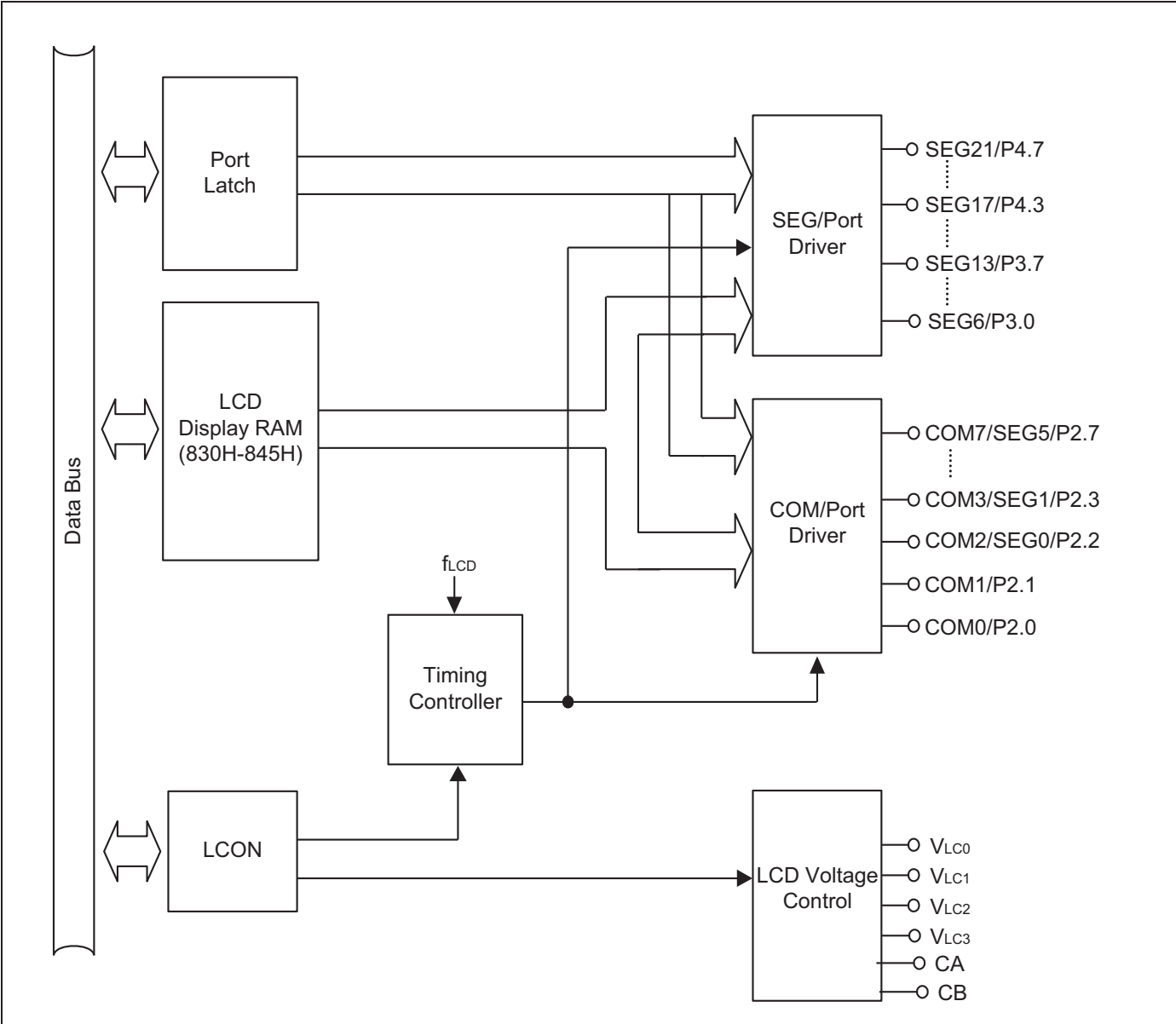


Figure 15-2 LCD Circuit Diagram

### 15.3 LCD RAM Address Area

RAM addresses of 30H–45H page 8 are used as LCD data memory. These locations can be addressed by 1-bit or 8-bit instructions. When the bit value of a display segment is "1", the LCD display is turned on; when the bit value is "0", the display is turned off.

Display RAM data are sent out through the segment pins, SEG0–SEG21 by using the direct memory access (DMA) method that is synchronized with the  $f_{LCD}$  signal. RAM addresses in this location that are not used for LCD display can be allocated to general-purpose use.

*Figure 15-3* illustrates the LCD display data Ram organization.

| COM  | Bit | SEG0 | SEG1 | SEG2 | SEG3 | SEG4 | ----- | SEG20 | SEG21 |
|------|-----|------|------|------|------|------|-------|-------|-------|
| COM0 | .0  |      |      |      |      |      |       |       |       |
| COM1 | .1  |      |      |      |      |      |       |       |       |
| COM2 | .2  |      |      |      |      |      |       |       |       |
| COM3 | .3  | 830H | 831H | 832H | 833H | 834H | ----- | 844H  | 845H  |
| COM4 | .4  |      |      |      |      |      |       |       |       |
| COM5 | .5  |      |      |      |      |      |       |       |       |
| COM6 | .6  |      |      |      |      |      |       |       |       |
| COM7 | .7  |      |      |      |      |      |       |       |       |

**Figure 15-3 LCD Display Data RAM Organization**

## 15.4 LCD Control Register (LCON)

A LCON is located in set 1, bank 1 at address FDH, and is read/write addressable by using register addressing mode. It has the following control functions.

- LCD duty and bias selection
- LCD clock selection
- LCD display control
- Internal/External LCD dividing resistors or capacitor bias selection

The LCON register is used to turn the LCD display on/off, to select duty and bias, to select LCD clock.

A reset clears the LCON registers to "00H" by:

- Configuring LCD display off
- Selecting 1/8 duty and 1/4 bias
- Selecting 128 Hz for LCD clock
- Not selecting any LCD bias type

The LCD clock signal determines the frequency of COM signal scanning of each segment output. This is also referred as the LCD frame frequency. Since the LCD clock is generated by watch timer clock (fw). The watch timer should be enabled when the LCD display is turned on.

**NOTE:** The clock and duty for LCD controller/driver is automatically initialized by hardware, whenever LCON register data value is re-write. Therefore, the LCON register does not re-write frequently.

Figure 15-4 illustrates the LCD control register (LCON).

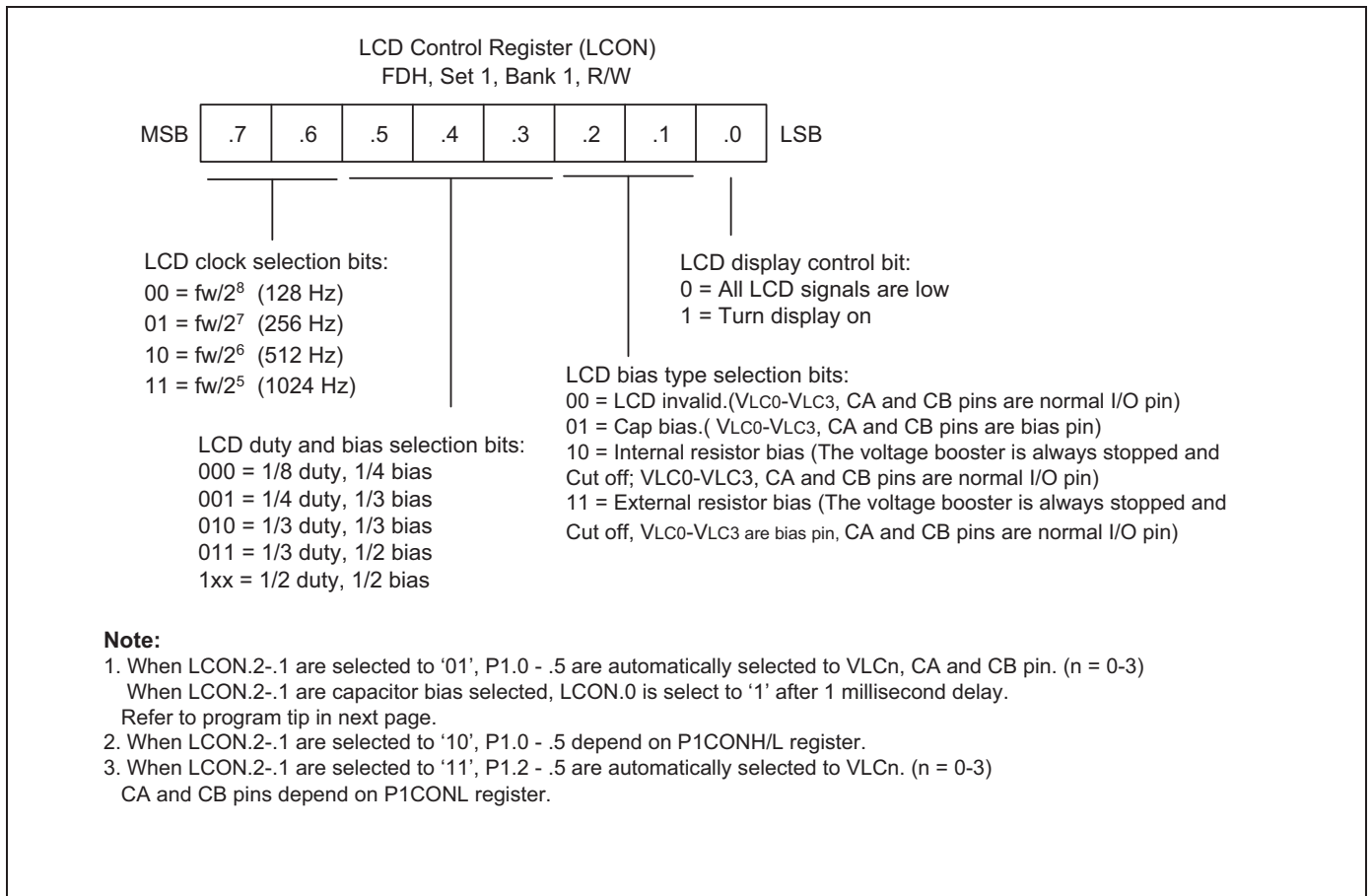


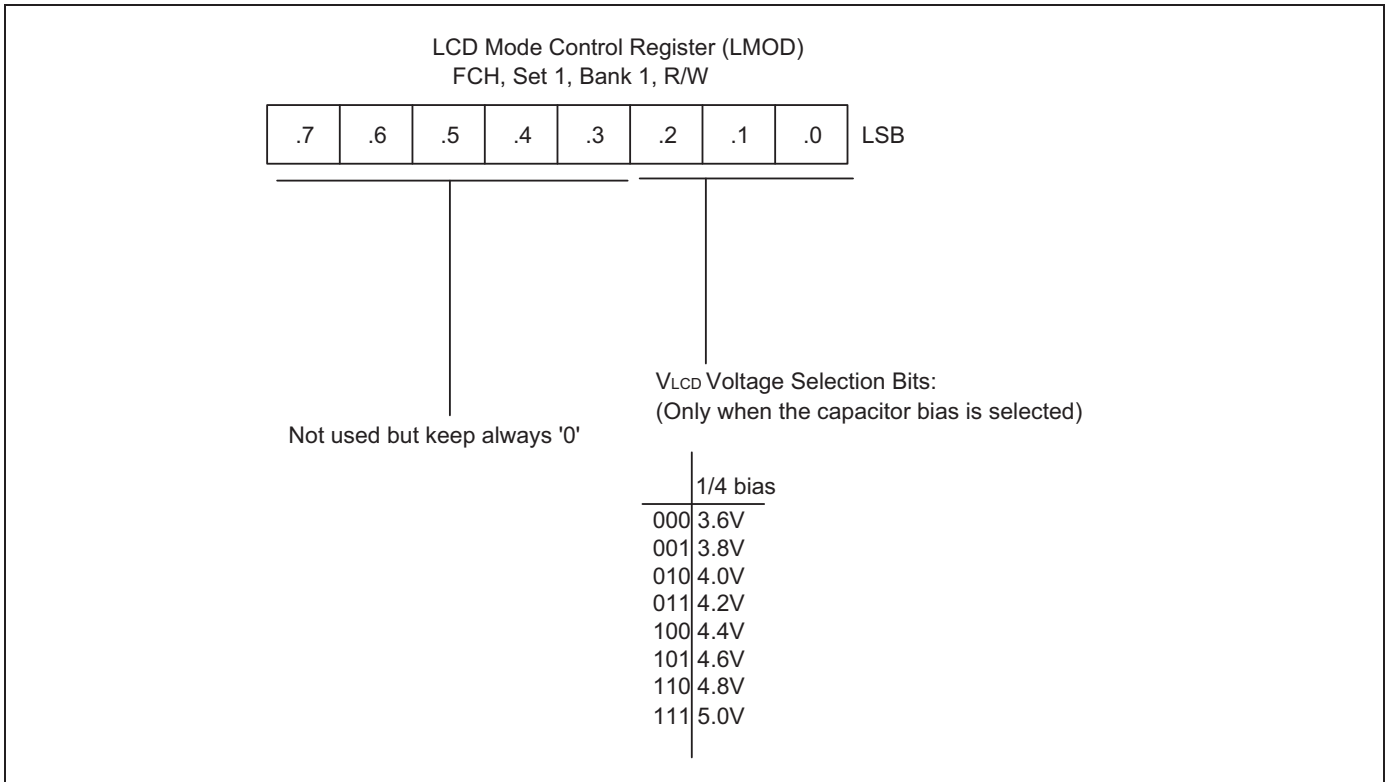
Figure 15-4 LCD Control Register (LCON)

## 15.5 LCD Mode Control Register (LMOD)

A LMOD is located in set 1, bank 0 at address FCH, and is read/write addressable by using Register addressing mode. The control function of LMOD is VLCD voltage selection.

The LMOD register is used to select VLCD voltage. A reset clears the LMOD registers to "00H" by configuring select 3.6 V (when 1/4 bias) for VLCD voltage.

[Figure 15-5](#) illustrates the LCD mode control register.



**Figure 15-5 LCD Mode Control Register (LMOD)**

15.6 Internal Resistor Bias Pin Connection

Figure 15-6 illustrates the internal resistor bias pin connection.

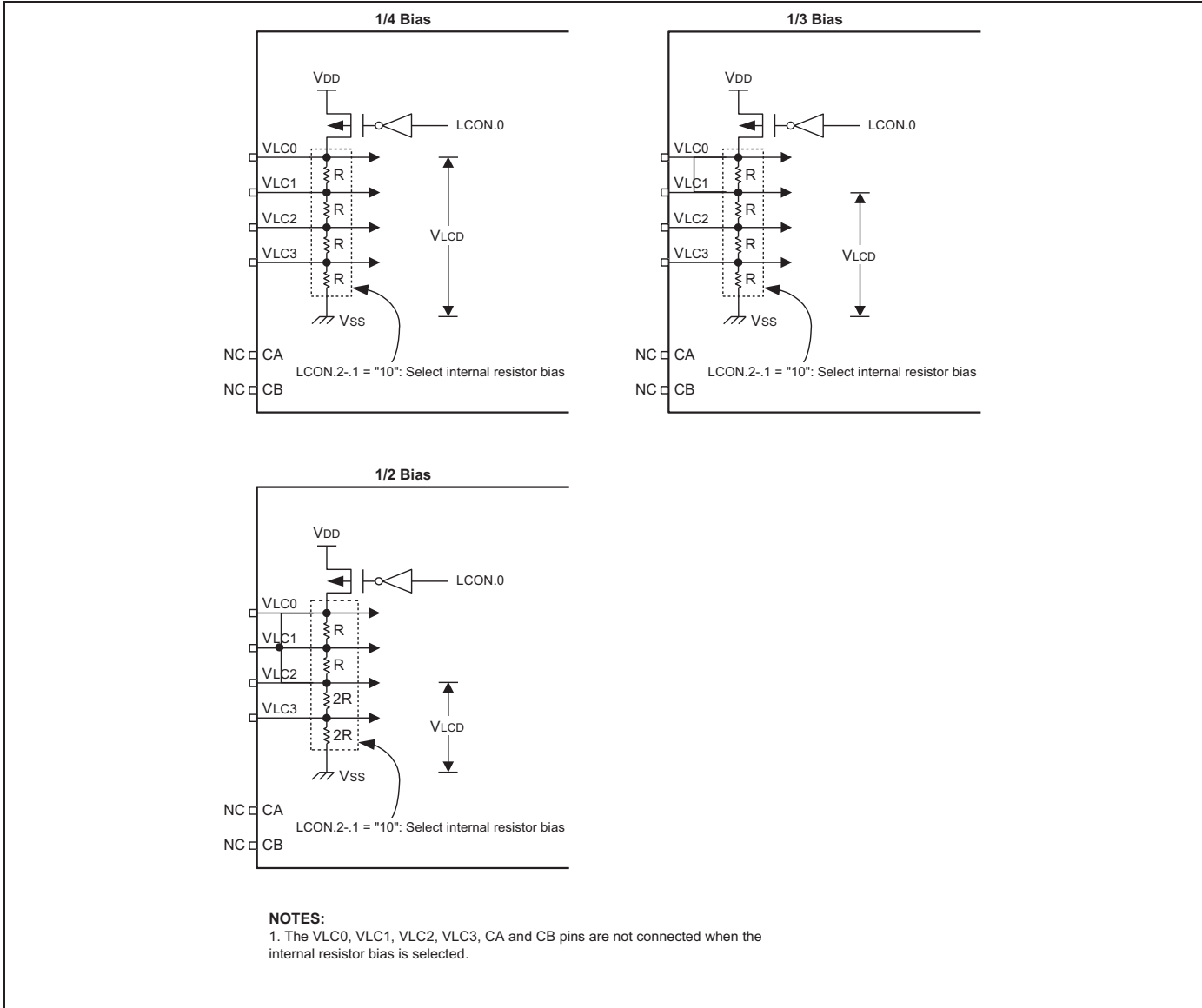


Figure 15-6 Internal Resistor Bias Pin Connection

## 15.7 External Resistor Bias Pin Connection

Figure 15-7 illustrates the external resistor bias pin connection.

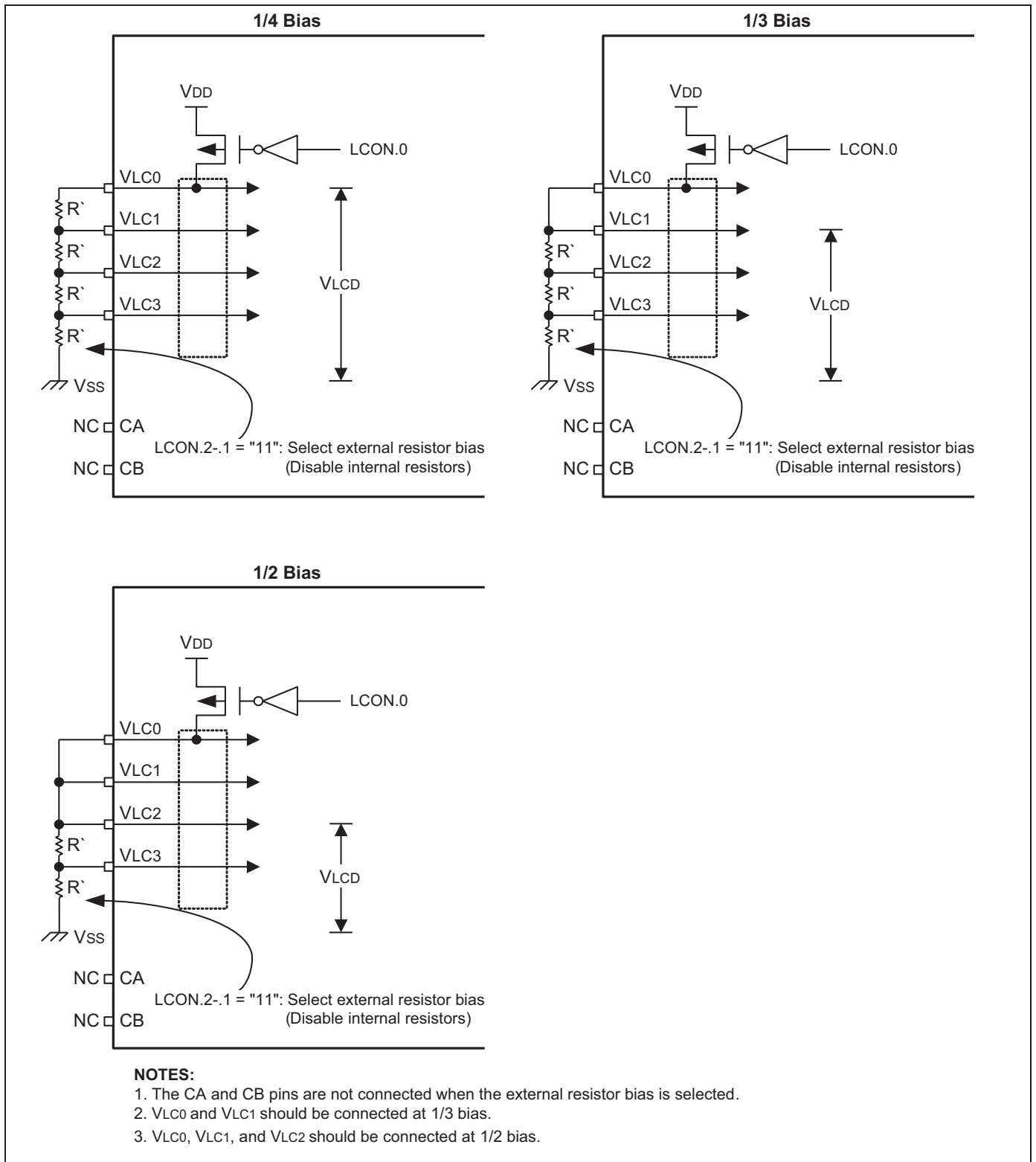


Figure 15-7 External Resistor Bias Pin Connection

### 15.8 Capacitor Bias Pin Connection

Figure 15-8 illustrates the capacitor bias pin connection.

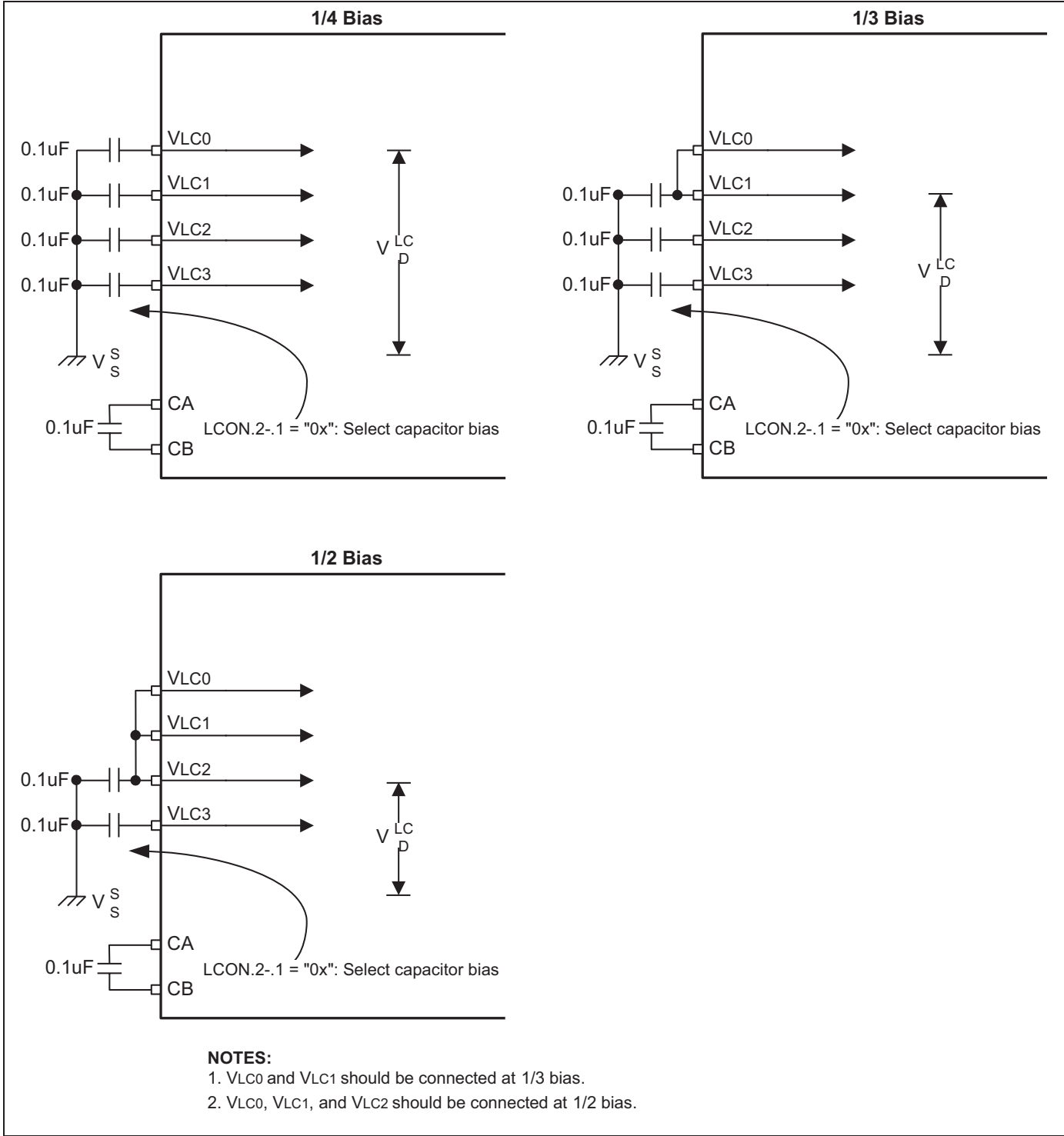


Figure 15-8 Capacitor Bias Pin Connection



### 15.9 Common (COM) Signals

The common signal output pin selection (COM pin selection) varies according to the selected duty cycle.

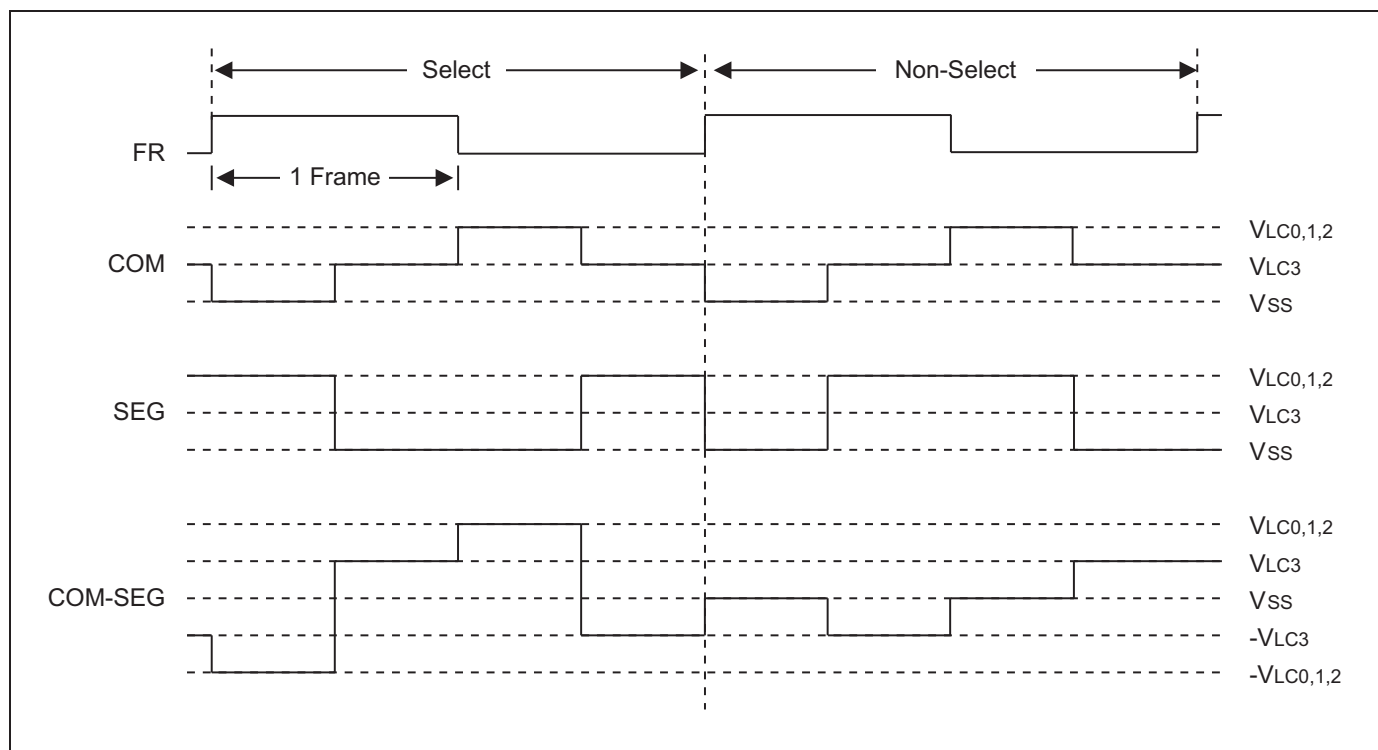
- In 1/8 duty mode, COM0-COM7 (SEG6–SEG21) pins are selected.
- In 1/4 duty mode, COM0-COM3 (SEG2–SEG21) pins are selected.
- In 1/3 duty mode, COM0-COM2 (SEG1–SEG21) pins are selected.
- In 1/2 duty mode, COM0-COM1 (SEG0–SEG21) pins are selected.

### 15.10 Segment (SEG) Signals

The 22 LCD segment signal pins are connected to corresponding display RAM locations at page 8. Bits of the display RAM are synchronized with the common signal output pins.

When the bit value of a display RAM location is "1", a select signal is sent to the corresponding segment pin. When the display bit is "0", it sends a 'no-select' signal to the corresponding segment pin.

[Figure 15-9](#) illustrates the select/no-select signal in 1/2 duty, 1/2 bias display mode.



**Figure 15-9 Select/No-Select Signal in 1/2 Duty, 1/2 Bias Display Mode**

Figure 15-10 illustrates the select/no-select signal in 1/3 duty, 1/3 bias display mode.

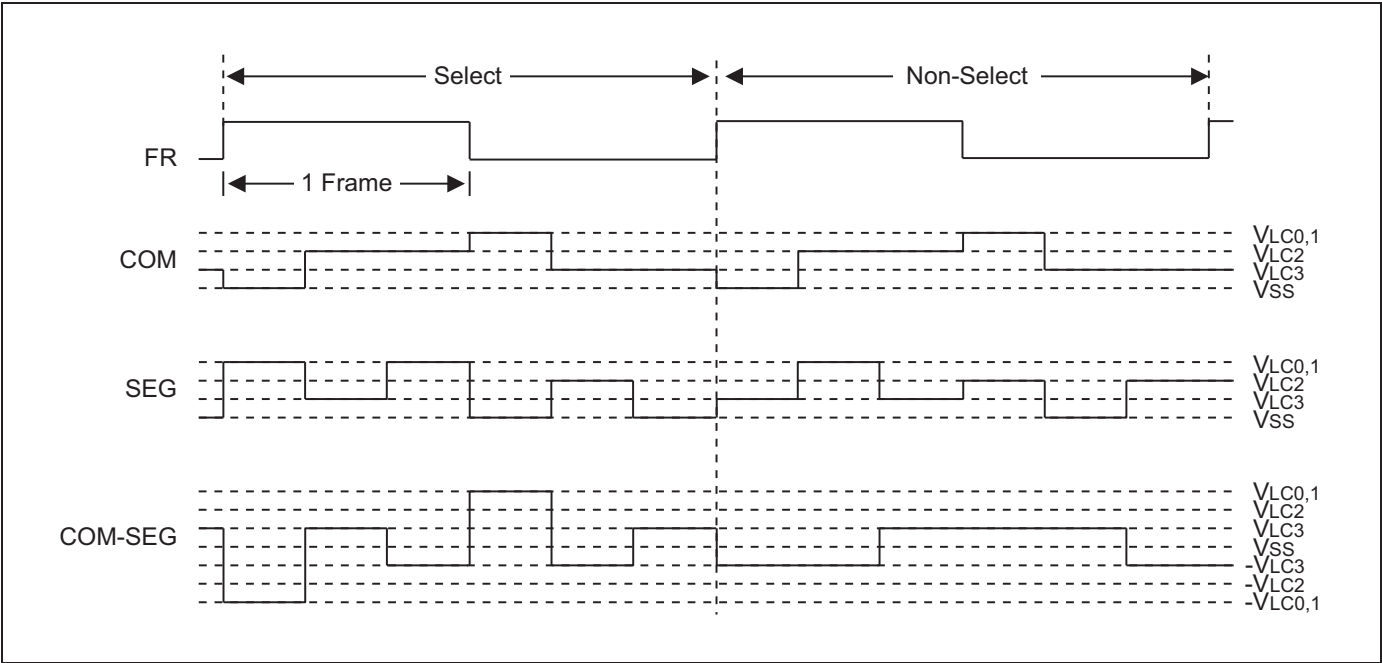


Figure 15-10 Select/No-Select Signal in 1/3 Duty, 1/3 Bias Display Mode

Figure 15-11 illustrates the LCD signal waveforms (1/2 Duty, 1/2 Bias).

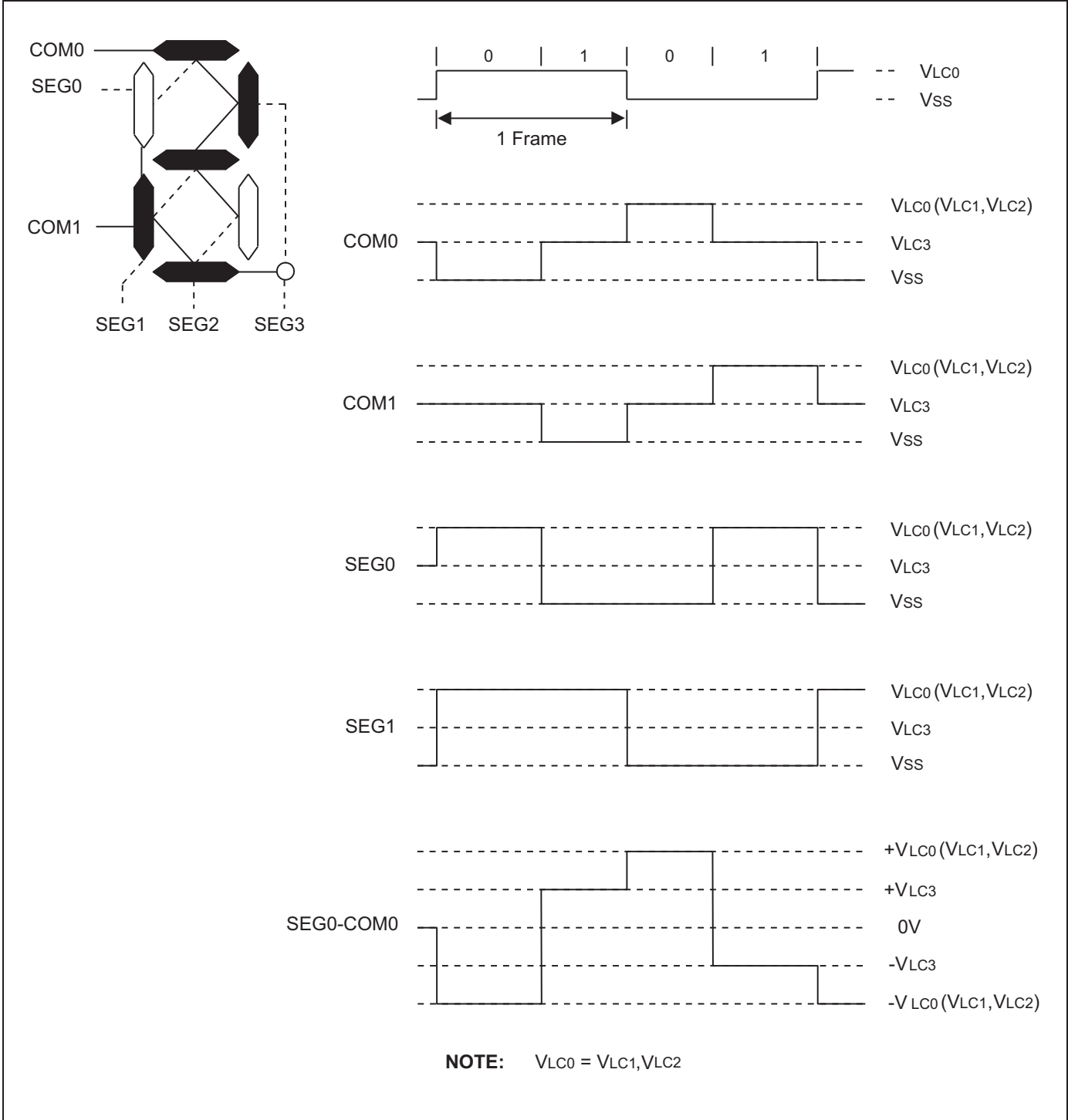


Figure 15-11 LCD Signal Waveforms (1/2 Duty, 1/2 Bias)

Figure 15-12 illustrates the LCD signal waveforms (1/3 Duty, 1/3 Bias).

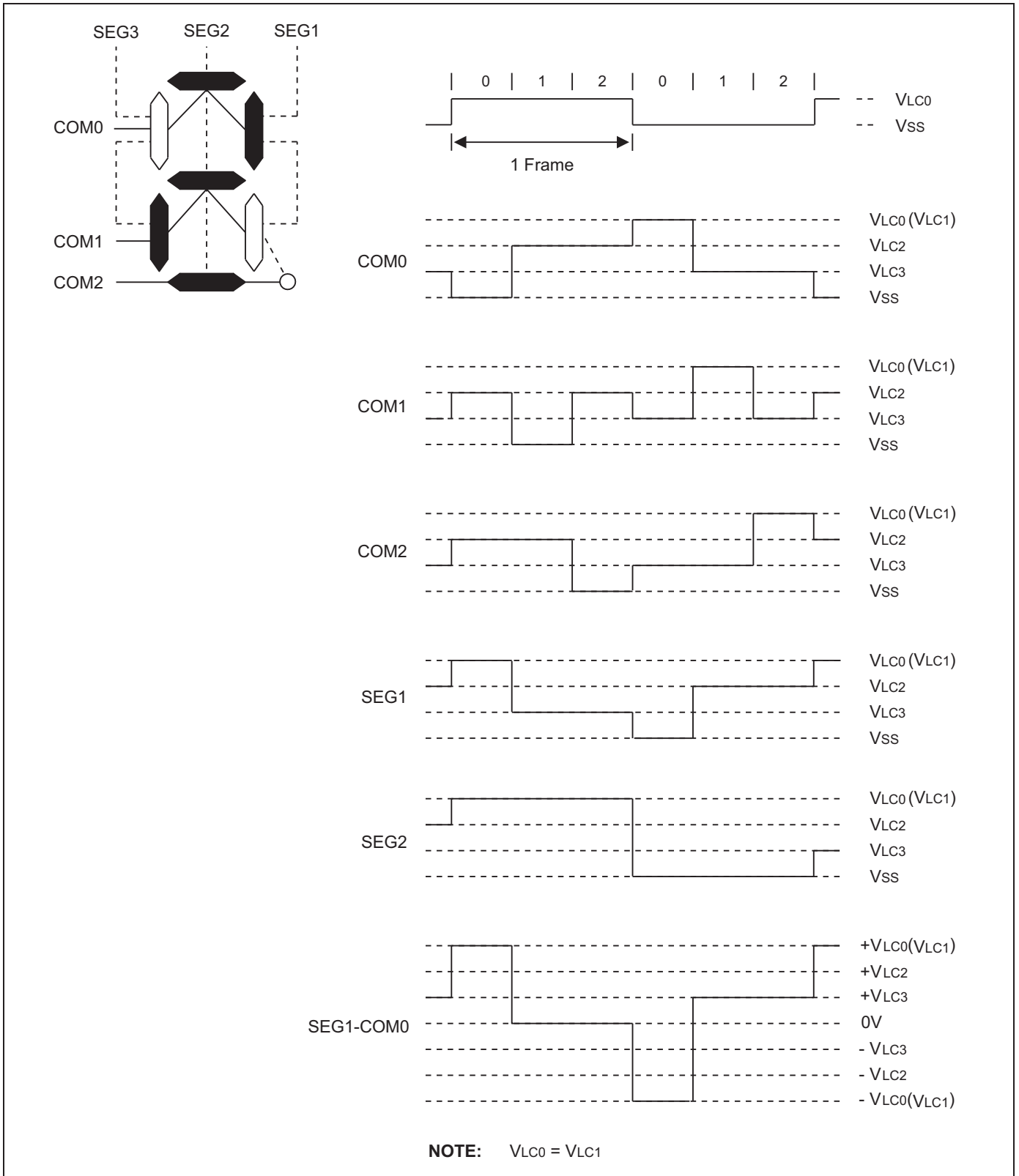


Figure 15-12 LCD Signal Waveforms (1/3 Duty, 1/3 Bias)

Figure 15-13 illustrates the LCD signal waveforms (1/4 Duty, 1/3 Bias).

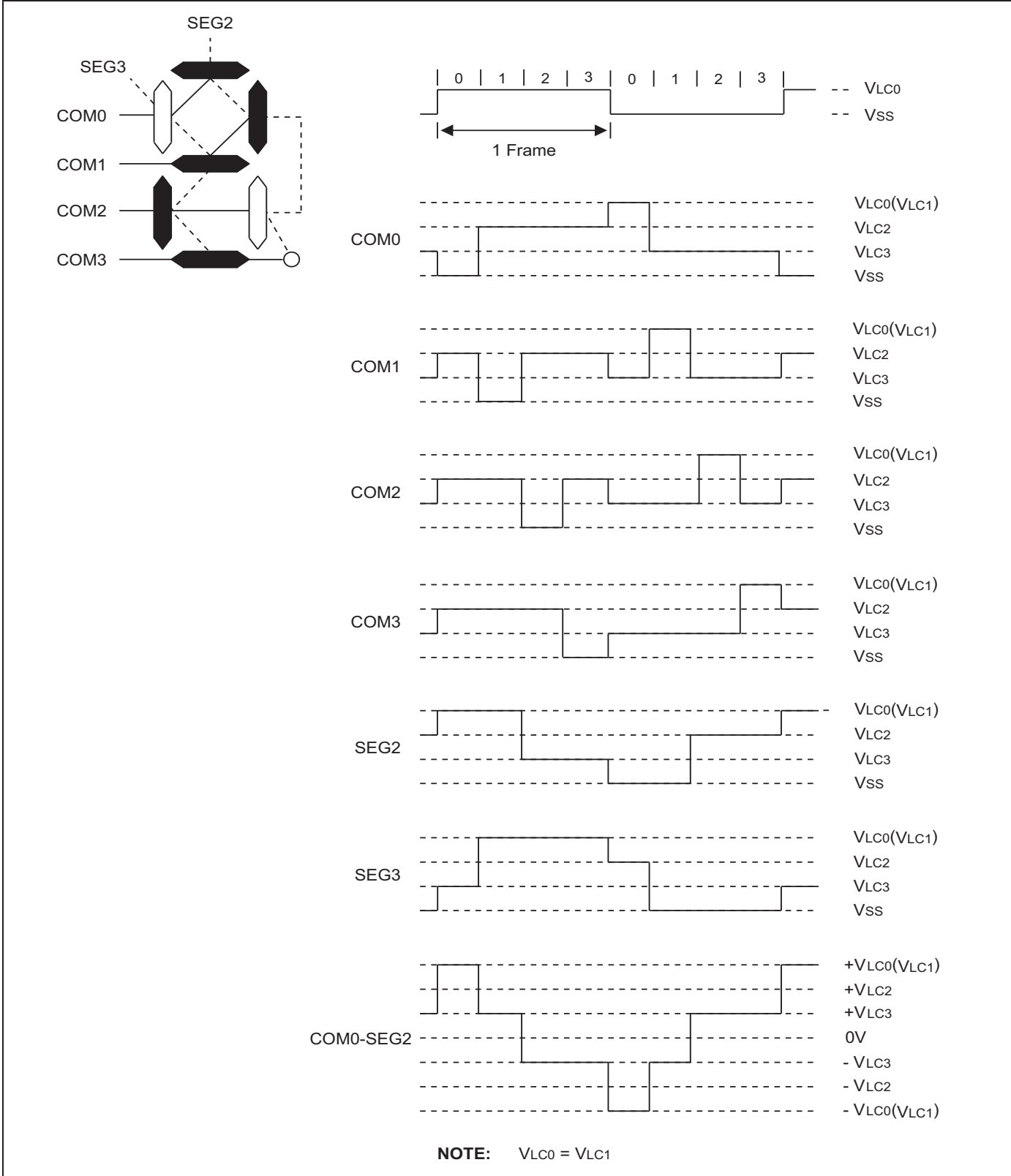
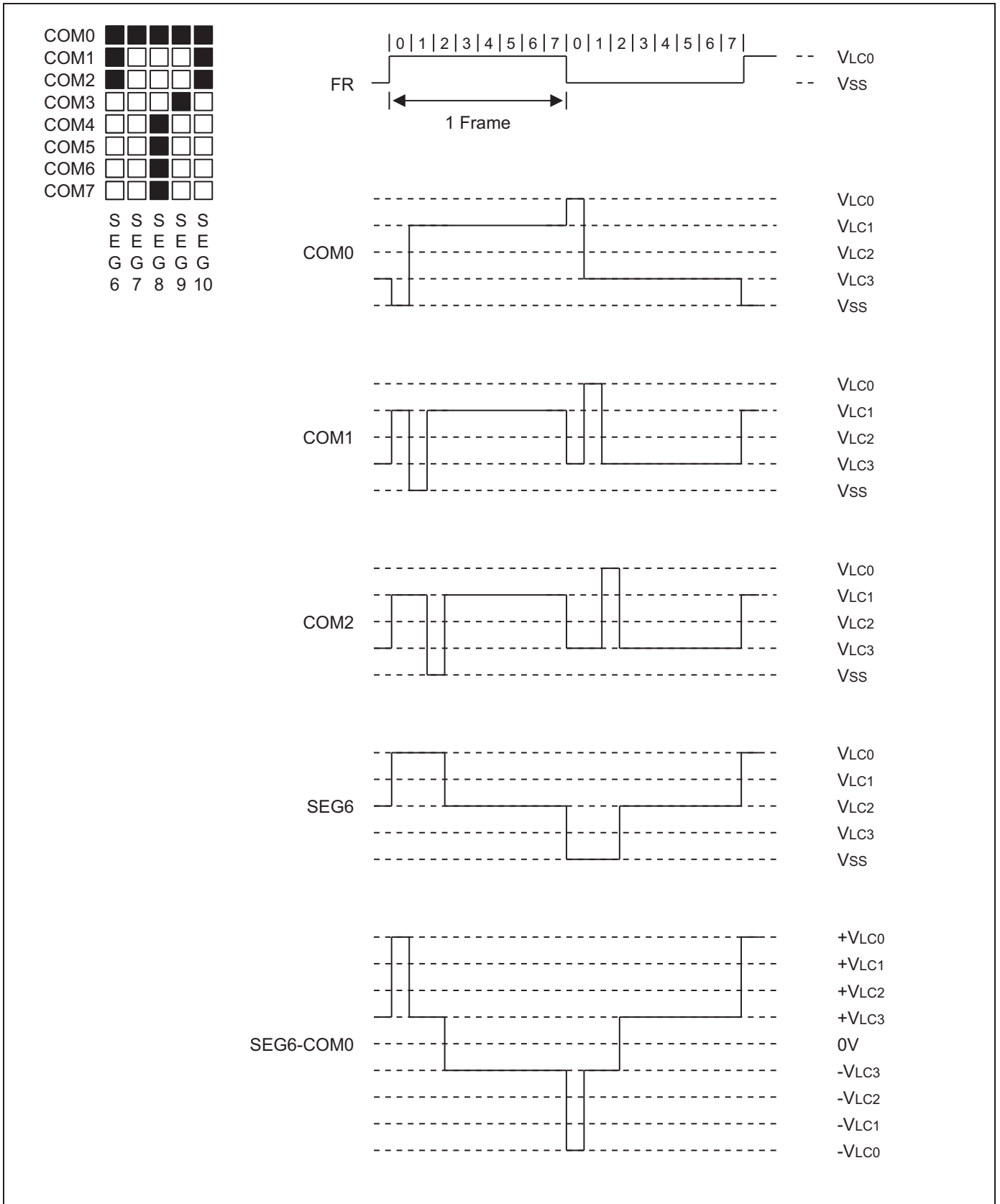


Figure 15-13 LCD Signal Waveforms (1/4 Duty, 1/3 Bias)

Figure 15-14 illustrates the LCD signal waveforms (1/8 Duty, 1/4 Bias).



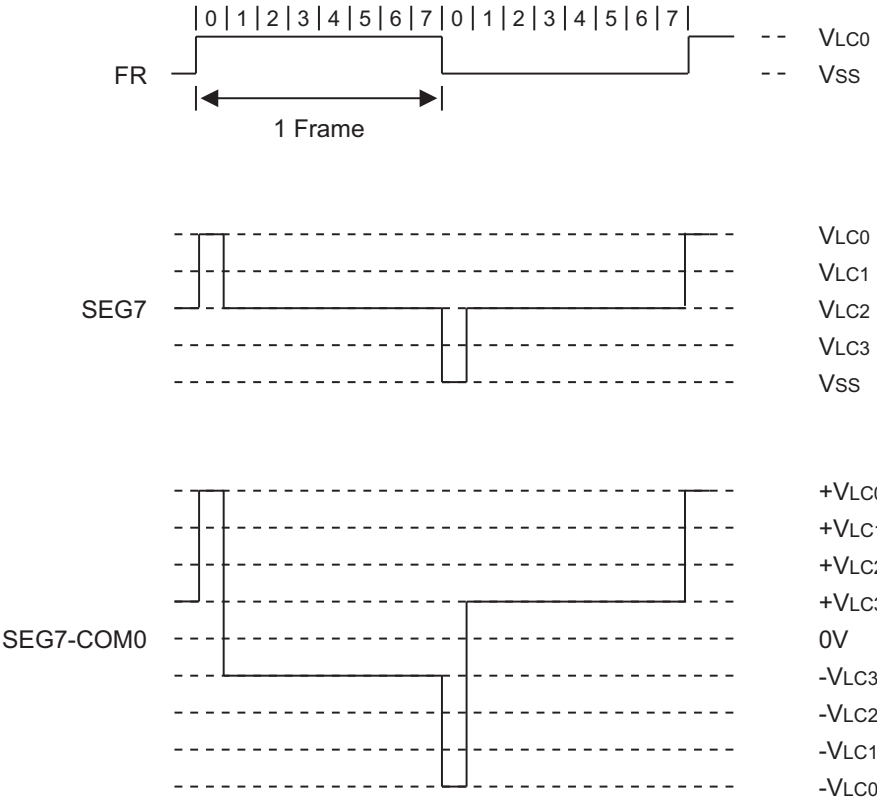


Figure 15-14 LCD Signal Waveforms (1/8 Duty, 1/4 Bias)

[Example 15-1](#) shows how to display LCD ON, after it selects Capacitor Bias.

### Example 15-1 LCD Display on, After Capacitor Bias Selected

This example shows how to display on after capacitor bias selected:

```
•
•
•
LCD_cap_bias
    AND    LCON, #0FBH
    OR     LCON, #02H      ; Capacitor bias select
    CALL   Delay1ms       ; Delay 1ms
    OR     LCON, #01H      ; Turn on LCD display
    RET

•
•
•
Delay1ms
    LD     R0, #20H
    DEL   NOP
    DJNZ  R0, DEL
    RET
```



# 16

## Analog/Digital Converter

### 16.1 Overview

A 10-bit A/D converter (ADC) module uses successive approximation logic to convert analog levels by entering at one of the eight input channels equivalent to 10-bit digital values. The analog input level should lie between the  $V_{DD}$  and  $V_{SS}$  values.

- The components A/D converter contains: Analog comparator with successive approximation logic
- Digital to analog (D/A) converter logic
- ADC control register (ADCON)
- Eight multiplexed analog data input pins (ADC0–ADC9)
- 10-bit A/D conversion data output register (ADDATAH/L)

The procedure to initiate an analog-to-digital conversion is:

- Write the channel selection data in the ADCON register to select one of the 16 analog input pins (ADC<sub>n</sub>, n = 0–15).
- Set the conversion start or enable bit, ADCON.0. The Read/Write ADCON register is placed in D2H, Set1.

During a normal conversion, ADC logic initially sets the successive approximation register to 200H (the approximate half-way point of a 10-bit register). This register is then updated automatically during each conversion step. The successive approximation block performs 10-bit conversions for one input channel at a time. You can dynamically select different channels by manipulating the channel selection bit value (ADCON.7–4) in the ADCON register. To start the A/D conversion, you should set the enable bit, ADCON.0.

When a conversion is completed, ACON.3, the end-of-conversion (EOC) bit is automatically set to 1 and the result is dumped into the ADDATA register where it can be read. The A/D converter then enters an idle state. Ensure to read the contents of ADDATA before another conversion starts. Otherwise, it will overwrite the previous result by the next conversion result.

**NOTE:** As the ADC does not use sample-and-hold circuitry, it is important that any fluctuations in the analog level at the ADC0 – ADC9 input pins during a conversion procedure be kept to an absolute minimum. Any change in the input level due to circuit noise invalidates the result.

### 16.1.1 Using A/D Pins for Standard digital Input

You can alternatively use the inputs pins of ADC module as digital input in port 0.

### 16.1.2 A/D Converter Control Register (ADCON)

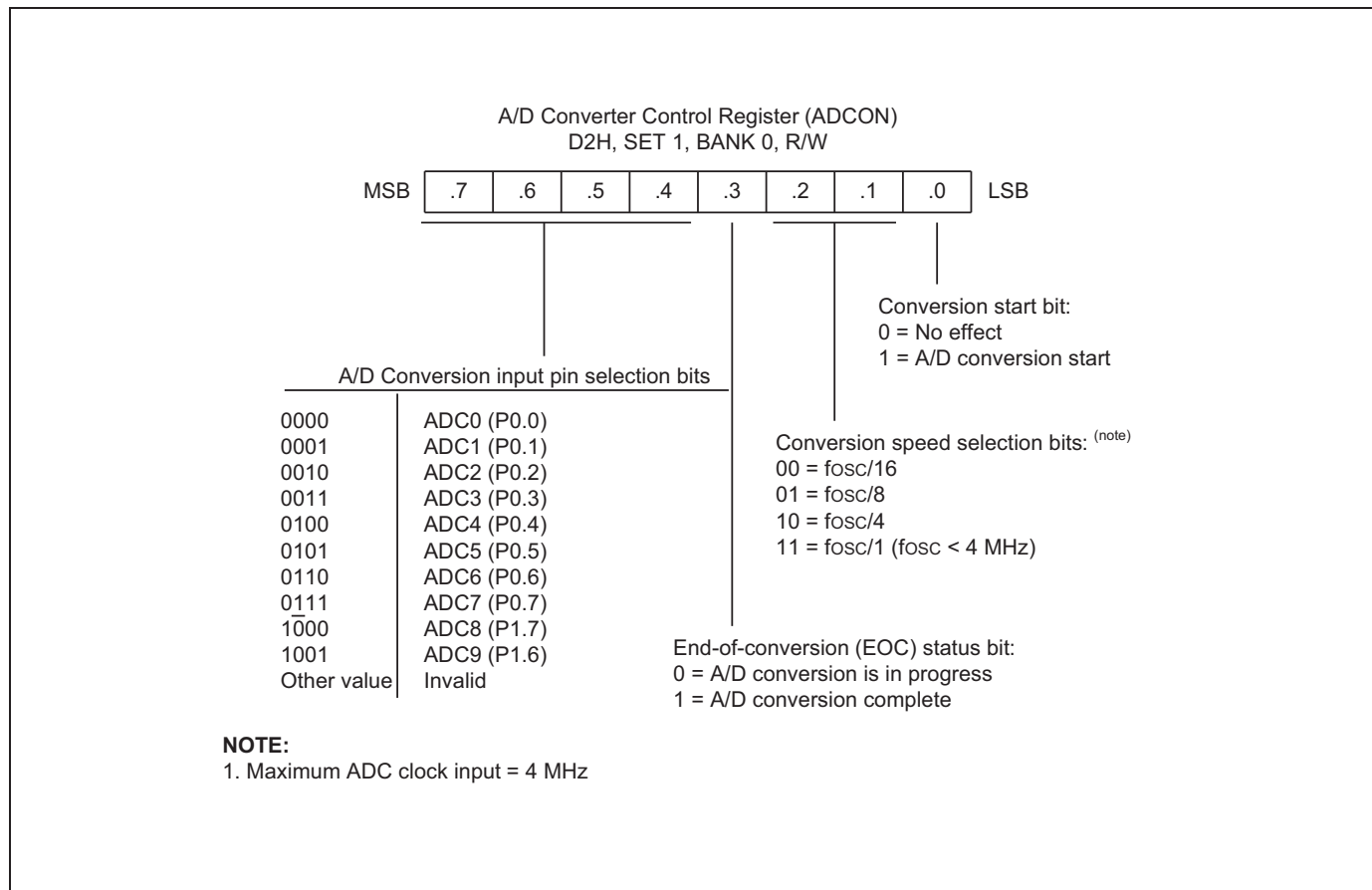
The A/D converter control register, ADCON, is located at address D2H.

ADCON has four functions:

- Bits 7-4 select an analog input pin (ADC0–ADC9).
- Bit 3 indicates the status of the A/D conversion.
- Bits 2-1 select a conversion speed.
- Bit 0 starts the A/D conversion.

You can select only one analog input channel at a time at a time. You can dynamically select any one of the eight analog input pins (ADC0–ADC9) by manipulating the 4-bit value for ADCON.7–ADCON.4.

[Figure 16-1](#) illustrates the A/D converter control register (ADCON).



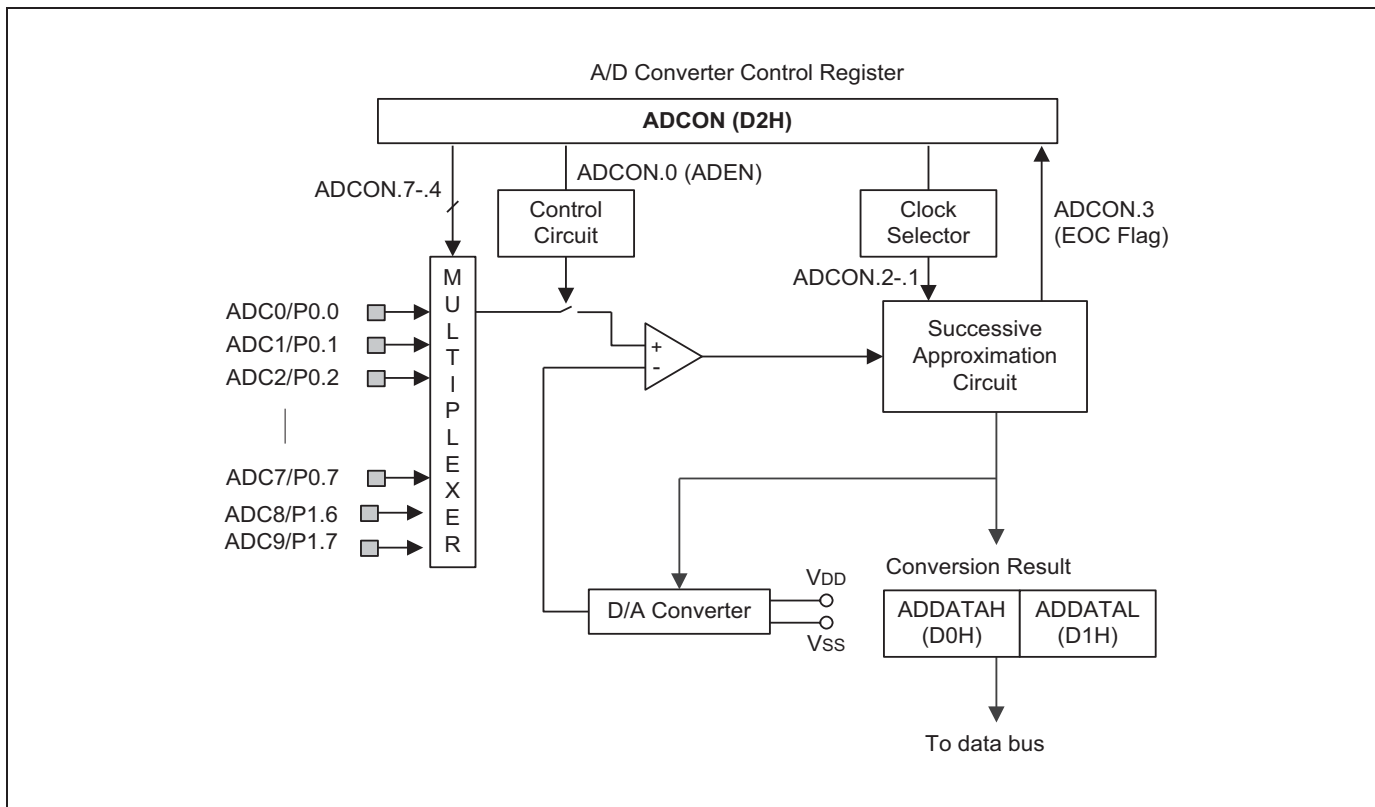
**Figure 16-1 A/D Converter Control Register (ADCON)**

### 16.1.3 Internal Reference Voltage Levels

In the ADC function block, it compares the analog input voltage to the reference voltage. The analog input level must remain within the range  $V_{SS}$  to  $V_{DD}$ .

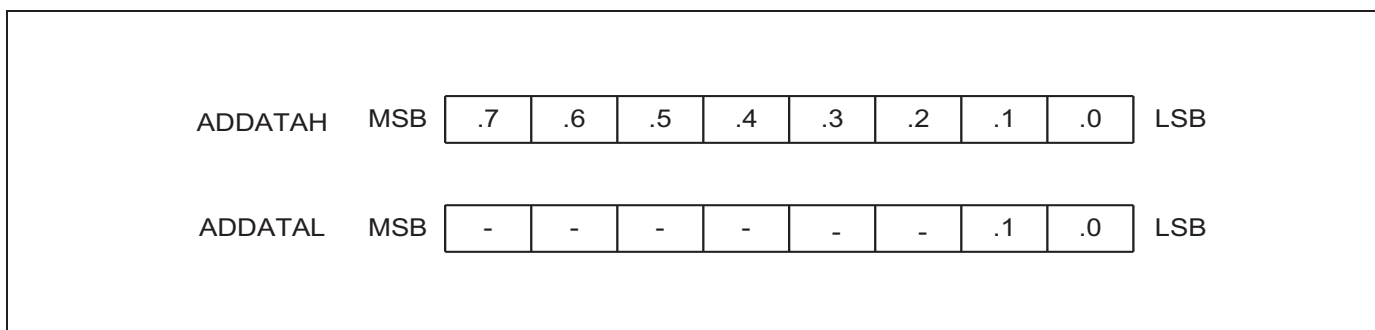
It generates different reference voltage levels internally along with the resistor tree during the analog conversion process for each conversion step. The reference voltage level for the first bit conversion is always  $1/2 V_{DD}$ .

[Figure 16-2](#) illustrates the circuit diagram of A/D converter.



**Figure 16-2 A/D Converter Circuit Diagram**

[Figure 16-3](#) illustrates the A/D converter data register.



**Figure 16-3 A/D Converter Data Register (ADDATAH/L)**

Figure 16-4 illustrates the timing diagram of A/D converter.

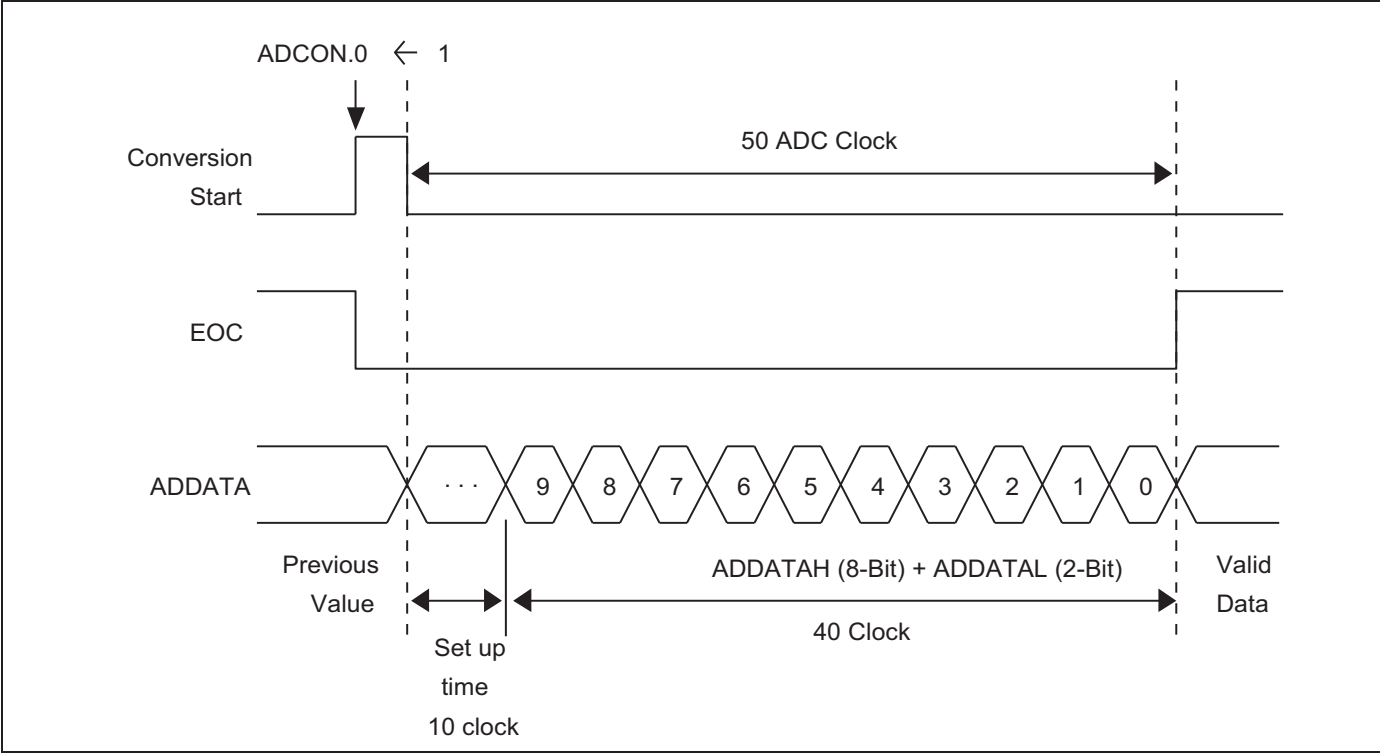


Figure 16-4 A/D Converter Timing Diagram

### 16.1.4 Conversion timing

The A/D conversion process requires four steps (four clock edges) to convert each bit and 10 clocks to step-up A/D conversion. Therefore, it requires total 50 clocks to complete a 10-bit conversion: With a 10 MHz CPU clock frequency, one clock cycle is 400 ns ( $4/f_{xx}$ ). If each bit conversion requires four clocks, the conversion rate is calculated as:

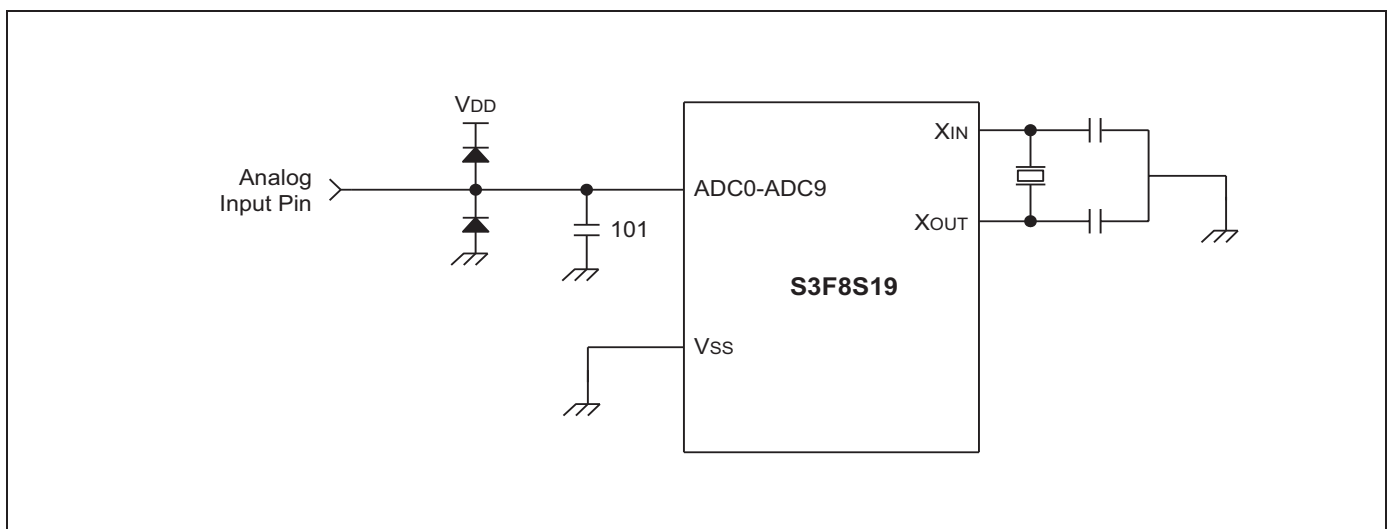
- $4 \text{ clocks/bit} \times 10\text{-bits} + \text{step-up time (10 clock)} = 50 \text{ clocks}$
- $50 \text{ clock} \times 400 \text{ ns} = 20 \mu\text{s}$  at 10 MHz, 1 clock time =  $4/f_{xx}$  (assuming  $\text{ADCON.2-1} = 10$ )

### 16.1.5 Internal A/D Conversion Procedure

The procedure for internal A/D Conversion is:

1. Analog input must remain between the voltage range of  $V_{SS}$  and  $V_{DD}$ .
2. Configure the analog input pins to input mode by making the appropriate settings in P0CONH, P0CONL registers.
3. Before the conversion operation starts, you must first select one of the eight input pins (ADC0–ADC7) by writing the appropriate value to the ADCON register.
4. It completes the conversion, (50 clocks have elapsed), set the EOC flag to "1", so that a check can be made to verify that the conversion was successful.
5. Loads the converted digital value to the output register, ADDATAH (8-bit) and ADDATAL (2-bit), and then the ADC module enters an idle state.
6. You can now read the digital conversion result from the ADDATAH and ADDATAL register.

[Figure 16-5](#) illustrates the recommended A/D converter circuit for highest absolute accuracy.



**Figure 16-5 Recommended A/D Converter Circuit for Highest Absolute Accuracy**

[Example 16-1](#) shows configuring A/D converter.

### Example 16-1 Configuring A/D Converter

```

;-----<< Interrupt Vector Address >>
        VECTOR    CEH, INT_TIMER A
;-----<< Smart Option >>
        ORG      003CH
        DB      0FFH           ; 003CH, must be initialized to FF
        DB      0FFH           ; 003DH, must be initialized to FF
        DB      0FFH           ; 003EH,
        DB      0FFH           ; 003FH, enable LVR 3.9V, internal RC oscillator 8MHz
        ORG      0100H
RESET:   DI          ; disable interrupt
        LD      BTCON, #10100011B ; Watchdog disable
        .
        .
        .
        LD      P0CONH, #10101010B ; Configure P0.4-P0.7 AD input
        LD      P0CONL, #10101010B ; Configure P0.0-P0.3 AD input

        EI          ; Enable interrupt
;-----<< Main loop >>
MAIN:    .
        .
        .
        CALL   AD_CONV           ; Subroutine for AD conversion
        .
        .
        .
        JR     t, MAIN           ;
AD_CONV: LD      ADCON, #00000001B ; Select analog input channel → P0.0
        ; select conversion speed → fOSC/16
        ; set conversion start bit

        NOP
        ; If you select conversion speed to fOSC/16
        ; at least one NOP must be included
CONV_LOOP: TM     ADCON, #00001000B ; Check EOC flag
        JR     Z, CONV_LOOP       ; If EOC flag=0, jump to CONV_LOOP until EOC flag=1
        LD     R0, ADDATAH        ; High 8 bits of conversion result are stored
        ; to ADDATAH register
        LD     R1, ADDATAL        ; Low 2 bits of conversion result are stored
        ; to ADDATAL register
        LD     ADCON, #00010011B ; Select analog input channel → P0.1
        ; Select conversion speed → fOSC/8
        ; Set conversion start bit
CONV_LOOP2: TM    ADCON, #00001000B ; Check EOC flag
        JR     Z, CONV_LOOP2
        LD     R2, ADDATAH
        LD     R3, ADDATAL
        .

```



```
•  
•  
RET ;  
  
INT_TIMER_A: • ;  
• ;  
• ; Pending bit clear  
IRET ;  
•  
•  
END
```

# 17

## Serial Peripheral Interface

### 17.1 Overview

The Serial Peripheral Interface (SPI) allows high-speed synchronous data transfer between the Micro controller (MCU) and peripheral devices or between several Samsung devices.

- Full-duplex, 4-wire Synchronous Data Transfer
- Master or Slave Operation
- Least Significant Bit (LSB) First or Most Significant Bit (MSB) First Data Transfer
- End of Transmission Interrupt Flag
- Write Collision Flag Protection
- Mode Fault Flag bit
- Wake-up from Idle Mode
- Double Speed Master SPI Mode

The S3F8S19/F8S15 SPI circuit supports byte serial transfers in either Master or Slave modes. [Figure 17-1](#). Illustrates the block diagram of the SPI circuit the block contains buffer for receive data for maximum flexibility and throughput. You can configure S3F8S19/F8S15 as either an SPI Master or Slave. The external interface consists of Master-Out/Slave-In (MOSI), Master-In/Slave-Out (MISO), Serial Clock (SCK), and Slave Select (NSS). You get the receive buffer contents by reading the SPI Data register (Refer to [Figure 17-5](#) for more information).

You can activate the SPI modes by setting the appropriate bits in the SPI Control Register (Refer to [Figure 17-5](#) for more information).



Figure 17-1 illustrates the block diagram of SPI.

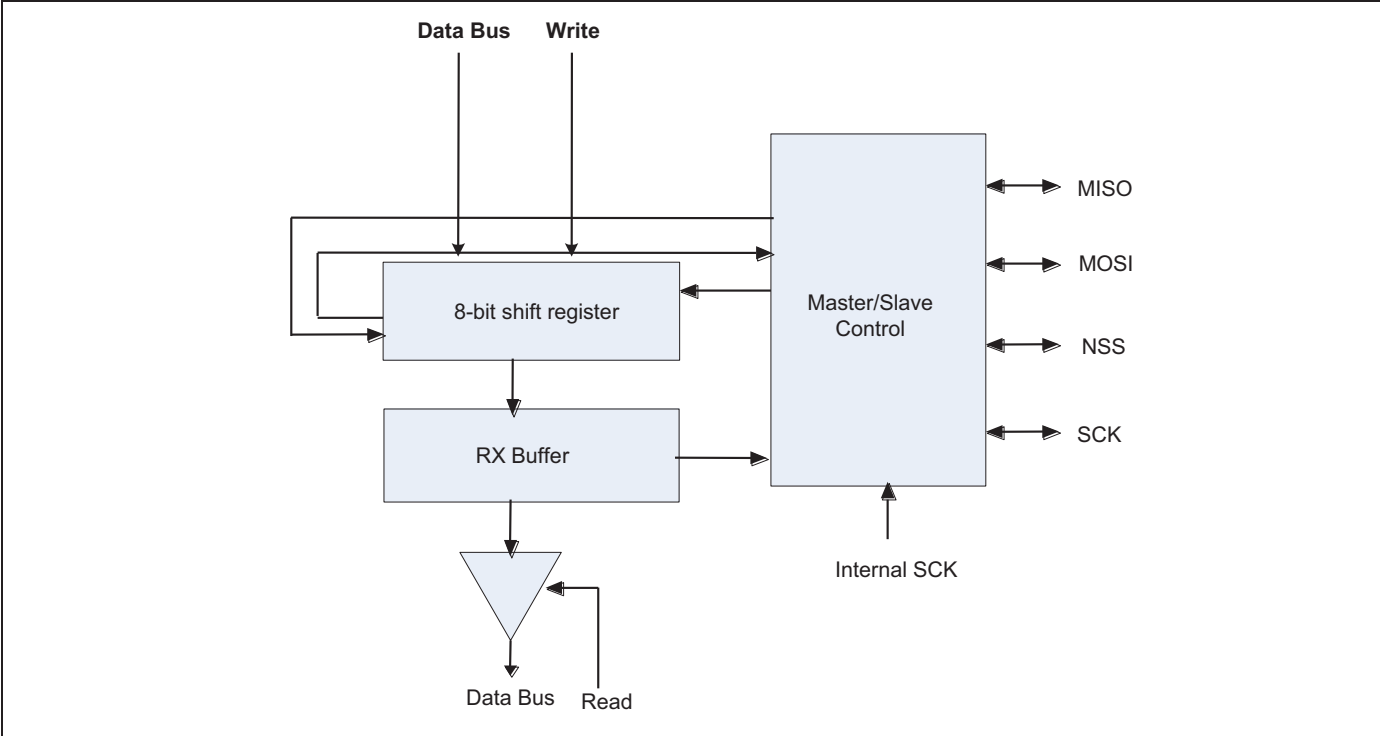


Figure 17-1 SPI Block Diagram

Figure 17-2 illustrates the data timing of SPI.

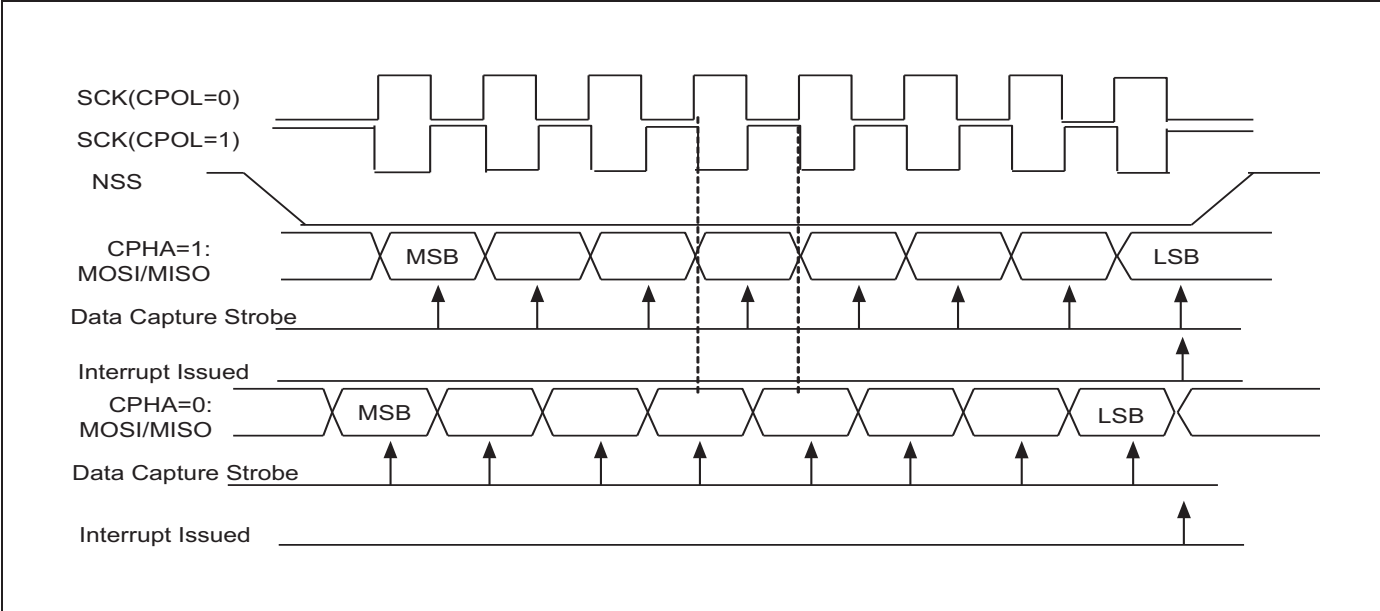


Figure 17-2 SPI Data Timing

## 17.2 Operation as an SPI Master

SPI Master can initiate a byte/data transfer and this is done by the Master writing to the SPI Data register. The Master shifts out 8 bits of data along with the serial clock SCK for the Slave. The Master's outgoing byte is replaced with an incoming one from a Slave device. When the last bit is received, the shift register contents are transferred to the Receive Buffer and an interrupt is generated. The receive data must be read from the SPI Data Register before it transfers the next byte of data to the receive buffer or data is lost.

When operating as a Master, an active LOW Slave Select (NSS) must be generated to enable a Slave for a byte transfer. This Slave Select is generated under firmware control, and is not part of the SPI internal hardware. Any available General purpose input output pin (GPIO) can be used for the Master's Slave Select Output.

When the Master writes to the SPI Data Register and if the shift register is not busy shifting a previous byte, then it loads the data into the shift register and begins the shifting. If the shift register is busy, then it generates a write collision error. The transfer continues undisturbed, and the write data that caused the error is not written to the shifter.

The byte shifting and SCK generation are handled by the hardware (based on firmware selection of the clock source). Data is shifted out on the MOSI pin and the serial clock is output on the SCK pin. Data is received from the slave on the MISO pin.

## 17.3 Master SCK Selection

The Master SCK is programmable to one of eight clock settings, as described in [Table 17-2](#). The frequency is selected with the Clock Select Bits of SPI control register and Double SPI Speed Bit of SPI status register. The hardware provides eight output clocks on the SCK pin for each byte transfer. Clock phase and polarity are selected by the CPHA and CPOL control bits (Refer to [Figure 17-3](#) for more information).

## 17.4 Operation as an SPI Slave

In Slave mode, the chip receives SCK from an external master on pin P3.2. Data from the master is shifted in on the MOSI pin, while data is being shifted out of the slave on the MISO pin. Additionally, it should assert the active LOW Slave Select to enable the slave for transmit. The Slave Select pin is P3.3. These pins are automatically configured by enabling SPI Enable bit.

In Slave mode, the data written to the SPI Data Register will be loaded into the shift register, only if the Slave Select is asserted (NSS LOW) and the shift register is not busy shifting a previous byte. If the register is busy, a write collision error is generated. The transfer continues undisturbed, and the write data that caused the error is not written to the shifter. If the Slave Select is not active when the data is loaded, data is not transferred to the shift register until Slave Select is asserted.

If the Slave Select is de-asserted before a byte transfer is complete, the transfer is aborted and no interrupt is generated. Whenever Slave Select is asserted, the data is automatically reloaded into the shift register.

You must select the clock phase and polarity to match the SPI master, using the control bits of SPICON (Refer to [Figure 17-3](#) for more information).

The SPI slave logic continues to operate in suspend, so if it enables the SPI interrupt, the device can go into suspend during a SPI slave transaction, and it wakes up at the interrupt that signals the end of the byte transfer.

## 17.5 SPI Status and Control

[Figure 17-3](#) illustrates the SPI control register. [Figure 17-2](#) illustrates the timing diagram that shows the clock and data states for the various SPI modes.

## 17.6 SPI Interrupt

For SPI, an interrupt request is generated after a byte is received or transmitted. After the interrupt, the received data byte can be read from the SPI Data Register and the SPI interrupt flag bit is high.

[Table 17-1](#) describes the SPI pin assignment.

**Table 17-1 SPI Pin Assignment**

| SPI Function                | GPIO Pin | Comment  |
|-----------------------------|----------|--|
| Slave Select (NSS)          | P3.3     | For Master Mode, Firmware sets NSS, can be used as GPIO pin. For Slave Mode, NSS is an active LOW input. |
| Master Out, Slave In (MOSI) | P3.1     | Data output for master, data input for slave.  |
| Master In, Slave Out (MISO) | P3.0     | Data input for master, data output for slave.  |
| SCK                         | P3.2     | SPI Clock: Output for master, input for slave.   |

[Table 17-2](#) lists the SCK rate selection.

**Table 17-2 SCK Rate Selection**

| SPICON.1-0 | SPISTAT.0 | SCK Rate |
|------------|-----------|----------|
| 00         | 1         | Fosc/2   |
| 00         | 0         | Fosc/4   |
| 01         | 1         | Fosc/8   |
| 01         | 0         | Fosc/16  |
| 10         | 1         | Fosc/32  |
| 10         | 0         | Fosc/64  |
| 11         | 1         | Fosc/128 |
| 11         | 0         | Fosc/256 |

## 17.7 SPI System Errors

Two system errors can be detected by the SPI system. The first type of error arises in a multiple-master system when multiple SPI devices simultaneously try to be a master. This error is called a mode fault. The second type of error, write collision, indicates that an attempt was made to write data to the SPIDATA, while a transfer was in progress.

When the SPI system is configured as a master and the NSS input line goes to active low, a mode fault error has occurred—usually because two devices have attempted to act as master at the same time. In cases where more than one device is concurrently configured as a master, there is a chance of contention between two pin drivers. For push-pull CMOS drivers, this contention can cause permanent damage. The mode fault mechanism attempts to protect the device by disabling the drivers. It clears the master/slave selection bit in the SPICON and all four P3CON control bits that are associated with the SPI. If NSS is an input and is driven low when the SPI is in Master mode, this will also set the SPI Interrupt Flag. SPIF is cleared by hardware when executing the corresponding interrupt handling vector. Alternatively, the SPIF bit is cleared by reading the SPI Status Register with SPIF set, then accessing the SPI Data Register (SPIDATA).

Other precautions may need to be taken to prevent driver damage. If two devices are made masters simultaneously, mode fault does not help protect either one unless one of them selects the other as slave. The amount of damage possible depends on the length of time both devices attempt to act as master.

A write collision error occurs if it writes the SPIDATA when a transfer is in progress. Because it does not double buffer the SPIDATA in the transmit direction, writes to SPIDATA cause data to be written directly into the SPI shift register. Because this write corrupts any transfer in progress, it generates a write collision error. The transfer continues undisturbed, and the write data that caused the error is not written to the shifter.

A write collision is normally a slave error because a slave has no control over when a master initiates a transfer. A master knows when a transfer is in progress, so there is no reason for a master to generate a write-collision error, although the SPI logic can detect write collisions in both master and slave devices.

## 17.8 SPI Control Register

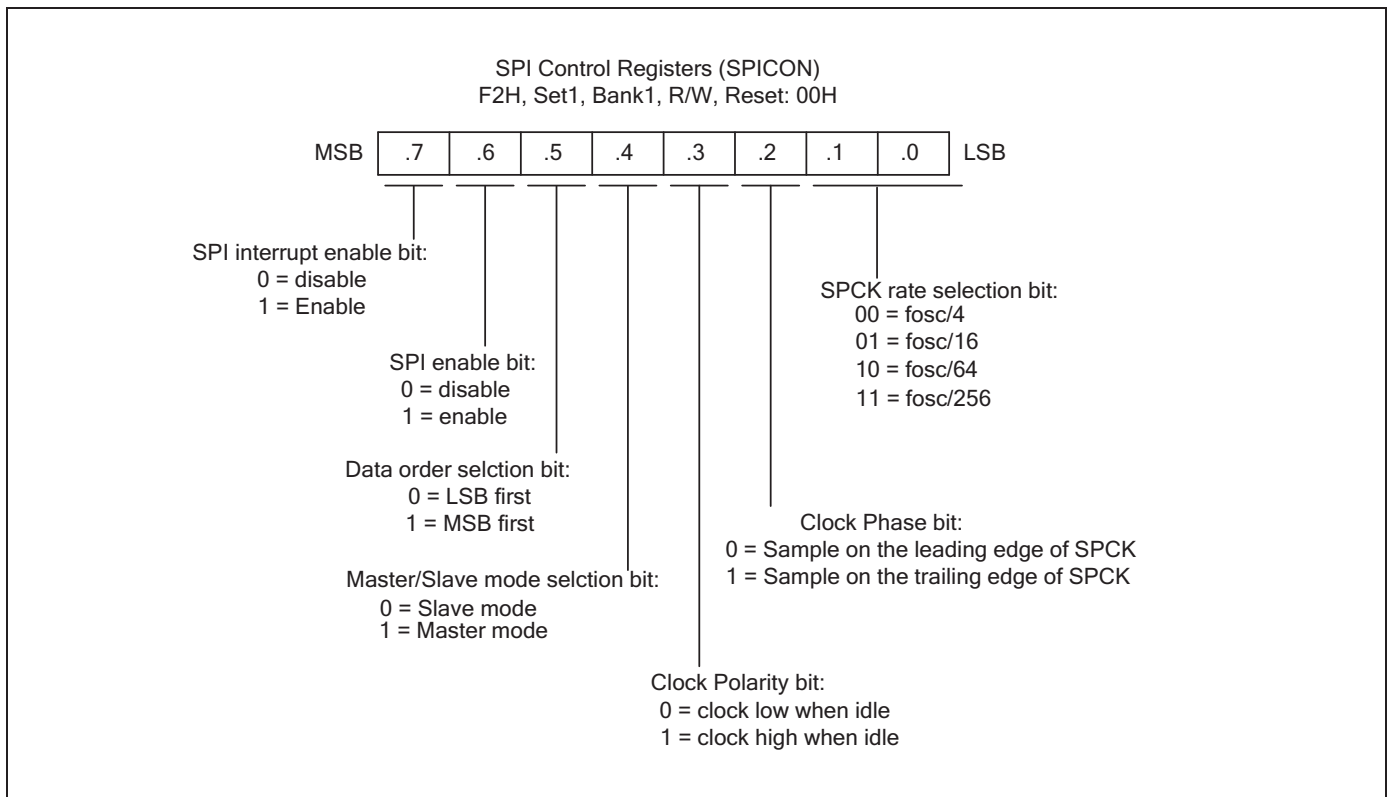
The control register for the SPI is called SPI Control Register (SPICON) at address F4H, Bank1.

It has the following control functions:

- Operating mode and SCK rate selection
- Clock Phase and Clock Polarity selection
- Data order selection
- SPI Enable/Disable
- SPI Interrupt Enable/Disable

A reset clears the SPICON value to "00H". So, if you want to use SPI module, you must write appropriate value to SPICON.

[Figure 17-3](#) illustrates the SPI Control Register (SPICON).



**Figure 17-3 SPI Control Register (SPICON)**

### 17.9 SPI Status Register

Two system errors can be detected by the SPI system. The first type of error arises in a multiple-master system when multiple SPI devices simultaneously try to be a master. This error is called a mode fault. The second type of error, write collision, indicates that an attempt was made to write data to the SPDR, while a transfer was in progress.

The control register for the SPI is called SPISTAT at address F5H, Bank1.

It has the following control functions:

- Double SPI speed
- SPI interrupt flag
- Write collision flag
- Mode fault flag

Clearing the Write Collision bit is accomplished by reading the SPISTAT (with Write Collision bit set) followed by an access of SPIDATA.

To clear the Mode fault bit, read the SPISTAT (with Mode Fault bit set), then write to the SPICON.

SPIF is cleared by hardware when executing the corresponding interrupt handling vector. Alternatively, it clears the SPIF bit by first reading the SPI Status Register with SPIF set, then accessing the SPI Data Register (SPIDATA).

[Figure 17-4](#) illustrates the SPI Status Register (SPISTAT).

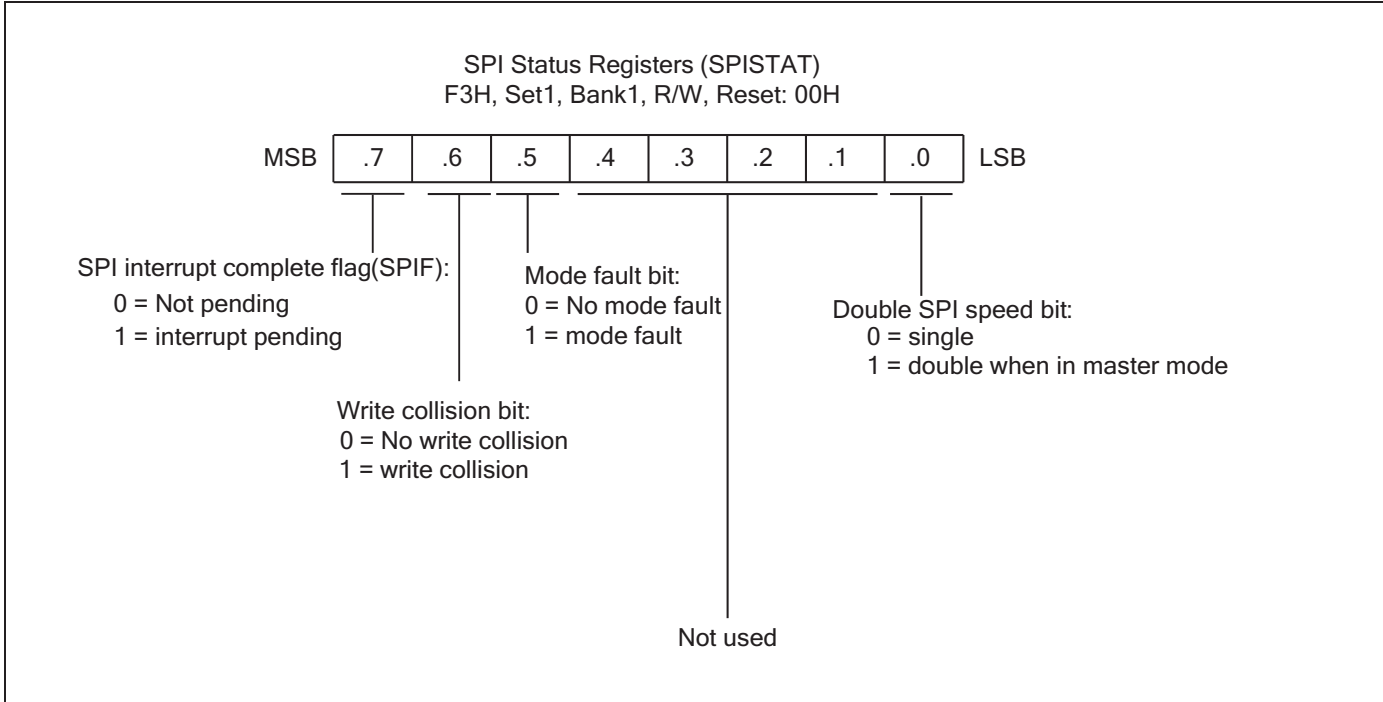


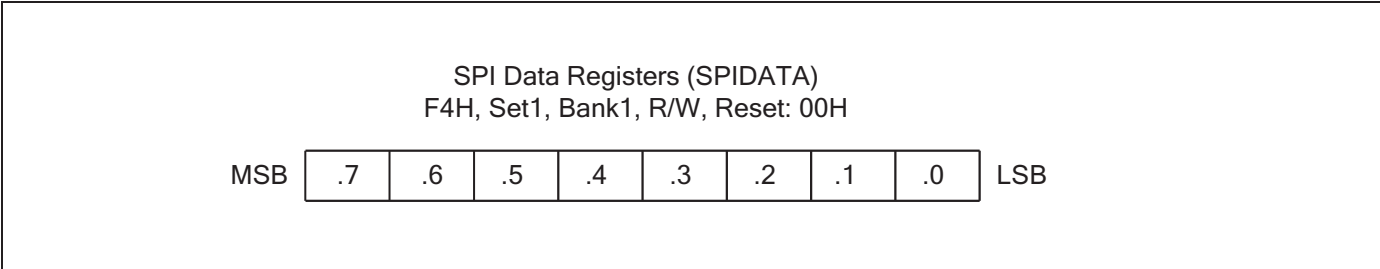
Figure 17-4 SPI Status Register (SPISTAT)

### 17.10 SPI Data Register

This register holds the SPI Data. The Firmware writes this register for transmitting data to External SPI Module. The Firmware reads the register to get data from the external SPI module.

SPIDATA is located at address F6H and is R/W addressable.

[Figure 17-5](#) illustrates the SPI Data Register (SPIDATA).



**Figure 17-5 SPI Data Register (SPIDATA)**



# 18

## Inter Integrated Circuit -Bus Interface

### 18.1 Overview

The S3F8S19/F8S15 microcontrollers support a multi-master Inter Integrated Circuit (IIC)-bus serial interface. A dedicated serial data line (SDA) and a serial clock line (SCL) transmit information between bus masters and peripheral devices that connects to the IIC-bus. The SDA and SCL lines are bi-directional.

In multi-master IIC-bus mode, multiple S3F8S19/F8S15 microcontrollers can receive or transmit serial data to or from slave devices. The master S3F8S19/F8S15, which initiates a data transfer over the IIC-bus, is responsible for terminating the transfer. S3F8S39/F8S38/F8S35/F8S34 microcontrollers support standard bus arbitration functions.

To control multi-master IIC-bus operations, you should write the values to these registers:

- IIC-bus control register (ICCR)
- IIC-bus control/status register (ICSR)
- IIC-bus Tx/Rx data shift register (IDSR)
- IIC-bus address register (IAR)

When the IIC-bus is free, the SDA and SCL lines are both at High level. A High-to-Low transition of SDA initiates a Start condition. A Low-to-High transition of SDA initiates a Stop condition, while SCL remains steady at High level.

The bus master always generates Start and Stop conditions. A 7-bit address value in the first data byte that is put onto the bus after the Start condition is initiated determines which slave device the bus master selects. The eighth bit determines the direction of the transfer (read or write).

Every data byte that is put onto the SDA line must total 8 bits. The number of bytes that can be sent or received per bus transfer operation is unlimited. Data is always sent most-significant bit (MSB) first and every byte must be immediately followed by an acknowledge (ACK) bit.

### 18.1.1 Multi-Master IIC-Bus Control Register

The multi-master IIC-bus control register (ICCR) is located at address Page 8, 0CH. It is Read/Write addressable.

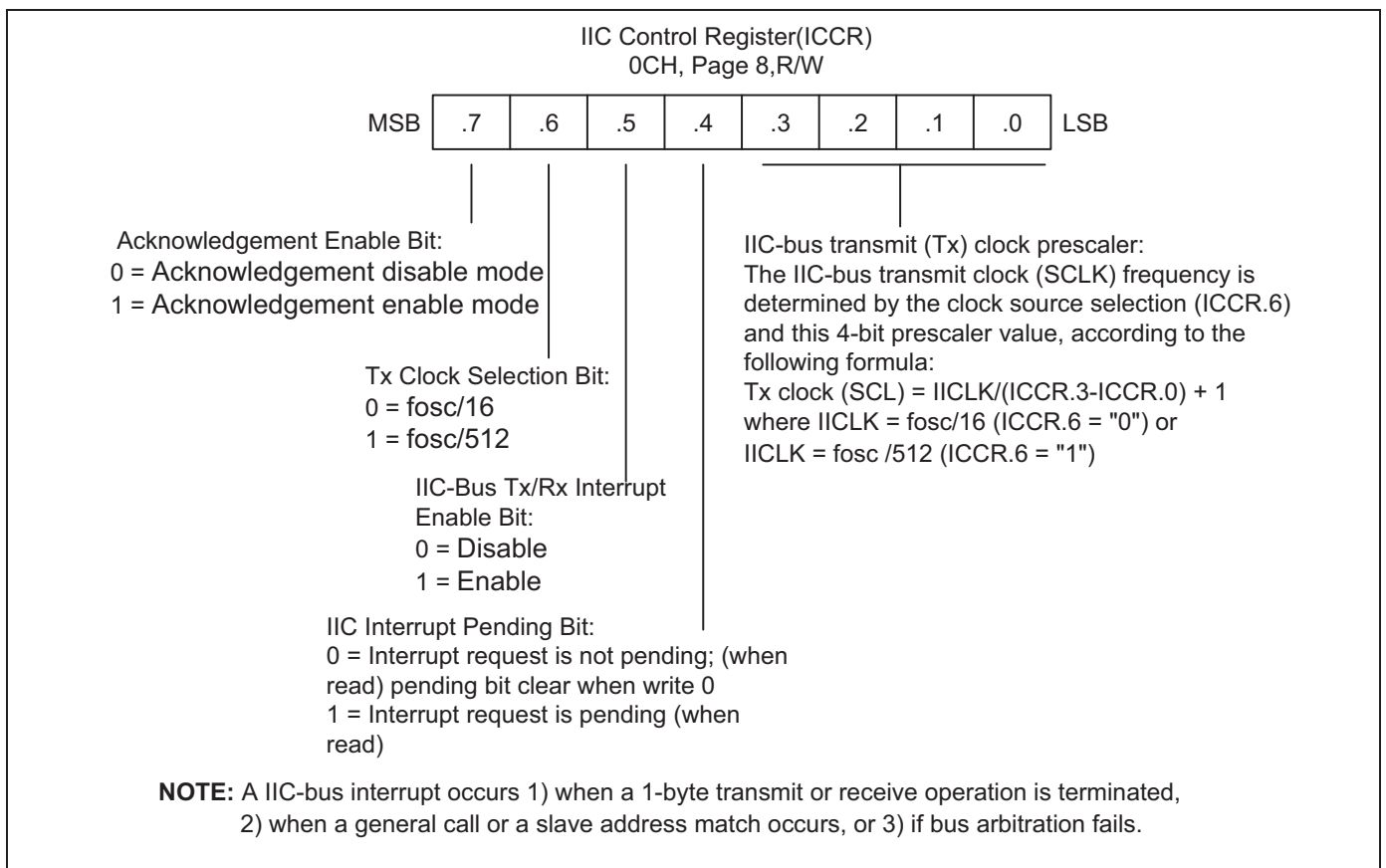
ICCR settings control these IIC-bus functions:

- Enables or suppresses CPU acknowledge signal (ACK)
- Selects IIC-bus clock source (fosc/16 or fosc/512)
- Transmits/receives interrupt enable or disable
- Transmits/receives interrupt pending control
- Provide 4-bit pre-scalar for the serial transmit clock (SCL)

In the S3F8S19/F8S15 interrupt structure, the IIC-bus Tx/Rx interrupt is assigned level IRQ4, vector E6H. To enable this interrupt, you should set ICCR.5 to "1". Program software then polls the IIC-bus Tx/Rx interrupt pending bit (ICCR.4) to detect IIC-bus receive or transmit requests. When the CPU acknowledges the interrupt request from the IIC-bus, the interrupt service routine should clear the interrupt pending condition by writing a "0" to ICCR.4.

The IIC-bus clock source selection (fosc/16 or fosc/512) and the 4-bit pre-scalar value in the ICCR register determine the SCL frequency (Refer to [Figure 18-1](#) for more information.).

[Figure 18-1](#) illustrates the multi-master IIC-bus control register.



**Figure 18-1 Multi-Master IIC-Bus Control Register (ICCR)**

[Table 18-1](#) lists the sample timing calculations for the IIC-bus transmit clock.

**Table 18-1 Sample Timing Calculations for the IIC-Bus Transmit Clock (SCL)**

| ICCR.3-ICCR.0<br>Value | IICLK<br>(ICCR.3-ICCR.0 Settings + 1) | (fosc = 8 MHz)<br>ICCR.6 = 0 (fosc/16)<br>IICLK = 500 kHz | (fosc = 8 MHz)<br>ICCR.6 = 1 (fosc/512)<br>IICLK = 15.625 kHz |
|------------------------|---------------------------------------|---|---|
| 0000                   | IICLK/1                               | 400 kHz (NOTE)  | 15.625 kHz  |
| 0001                   | IICLK/2                               | 250 kHz   | 7.1825 kHz  |
| 0010                   | IICLK/3                               | 167kHz  | 5.2038 kHz  |
| 0011                   | IICLK/4                               | 125 kHz   | 3.9063 kHz  |
| 0100                   | IICLK/5                               | 100 kHz   | 3.1250 kHz  |
| 0101                   | IICLK/6                               | 83.3 kHz  | 2.6042 kHz  |
| 0110                   | IICLK/7                               | 71.4 kHz  | 2.2321 kHz  |
| 0111                   | IICLK/8                               | 62.5 kHz  | 1.9531 kHz  |
| 1000                   | IICLK/9                               | 55.6 kHz  | 1.7361 kHz  |
| 1001                   | IICLK/10                              | 50 kHz  | 1.5625 kHz  |
| 1010                   | IICLK/11                              | 45.5 kHz  | 1.4205 kHz  |
| 1011                   | IICLK/12                              | 41.7 kHz  | 1.3021 kHz  |
| 1100                   | IICLK/13                              | 38.5 kHz  | 1.2019 kHz  |
| 1101                   | IICLK/14                              | 35.7 kHz  | 1.1160 kHz  |
| 1110                   | IICLK/15                              | 33.3kHz   | 1.0417 kHz  |
| 1111                   | IICLK/16                              | 31.25 kHz   | 0.9766 kHz  |

**NOTE:** Maximum IICLK = 400 kHz.

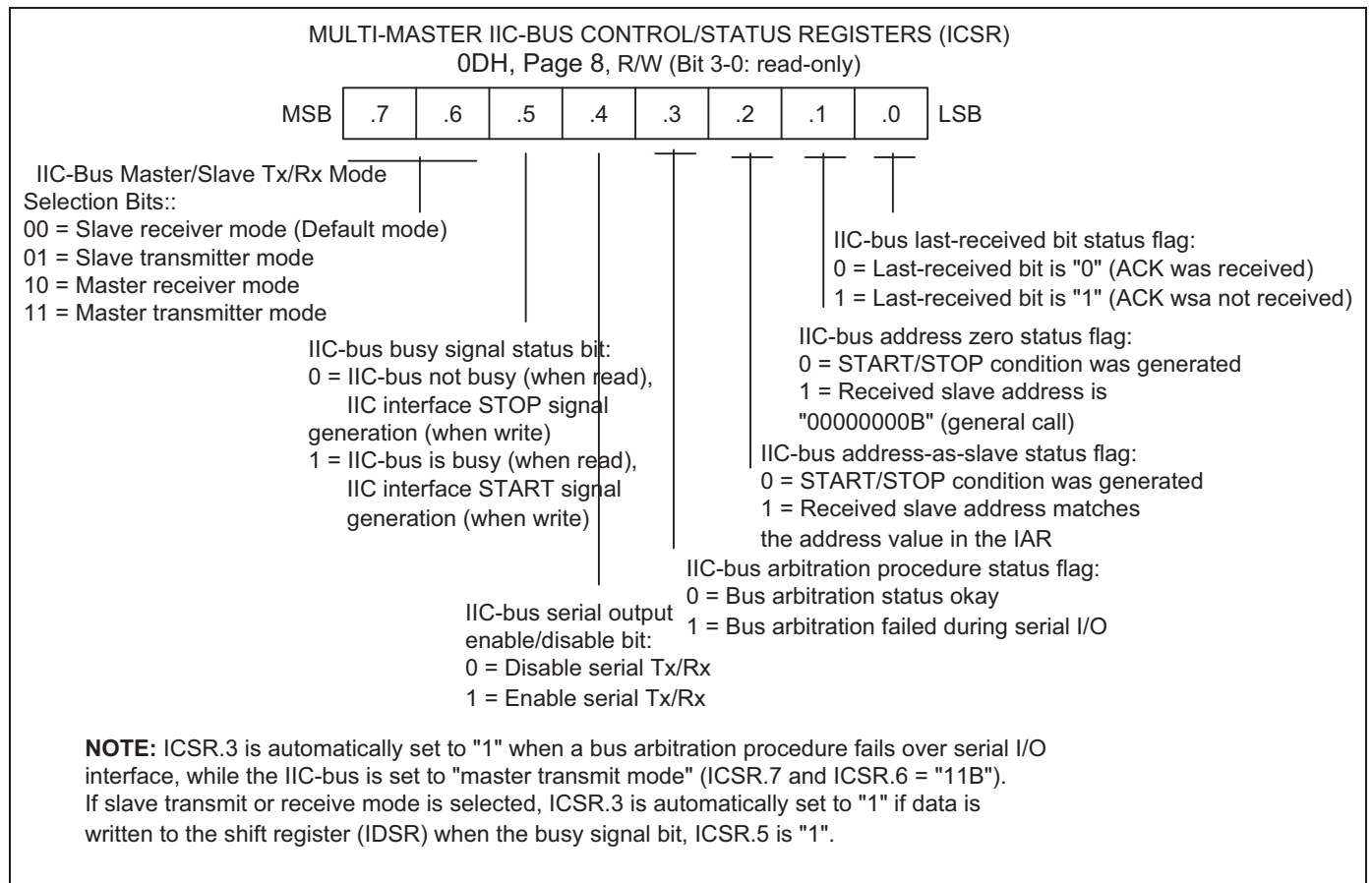
### 18.1.2 Multi-Master IIC-Bus Control/Status Register

The multi-master IIC-bus control/status register (ICSR) is located at address 0DH, Page 8. 4 bits in this register, ICSR.3-ICSR.0, are read-only status flags.

ICSR register settings are used to control or monitor the IIC-bus functions (Refer to [Figure 18-2](#) for more information). The IIC-bus functions are:

- Selects master/slave transmit or receive mode
- Provides an IIC-bus busy status flag
- Enables/disables Serial output
- Provides failed bus arbitration procedure status flag
- Provides slave address/address register match or general call received status flag
- Provides slave address 00000000B (general call) received status flag
- Provides last received bit status flag (not ACK = "1", ACK = "0")

[Figure 18-2](#) illustrates the multi-master IIC-bus control/status register.



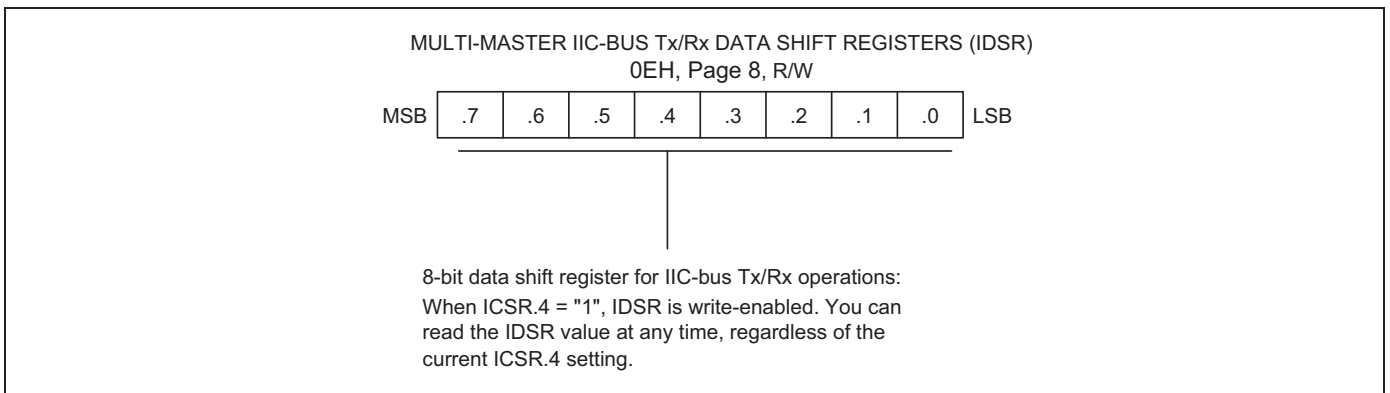
**Figure 18-2 Multi-Master IIC-Bus Control/Status Register (ICSR)**

### 18.1.3 Multi-Master IIC-Bus Transmit/Receive Data Shift Register

The IIC-bus data shift register (IDSR) is located at address 0EH, Page 8. In a transmit operation, data that is written to the IDSR is transmitted serially, and MSB first. (For receive operations, the input data is written into the IDSR register LSB first.)

The ICSR.4 setting enables or disables serial transmit/receive operations. When ICSR.4 = "1", data can be written to the shift register. However, you can read the IIC-bus shift register at any time, irrespective of the current ICSR.4 setting.

[Figure 18-3](#) illustrates the multi-master IIC-bus Tx/Rx data shift register.



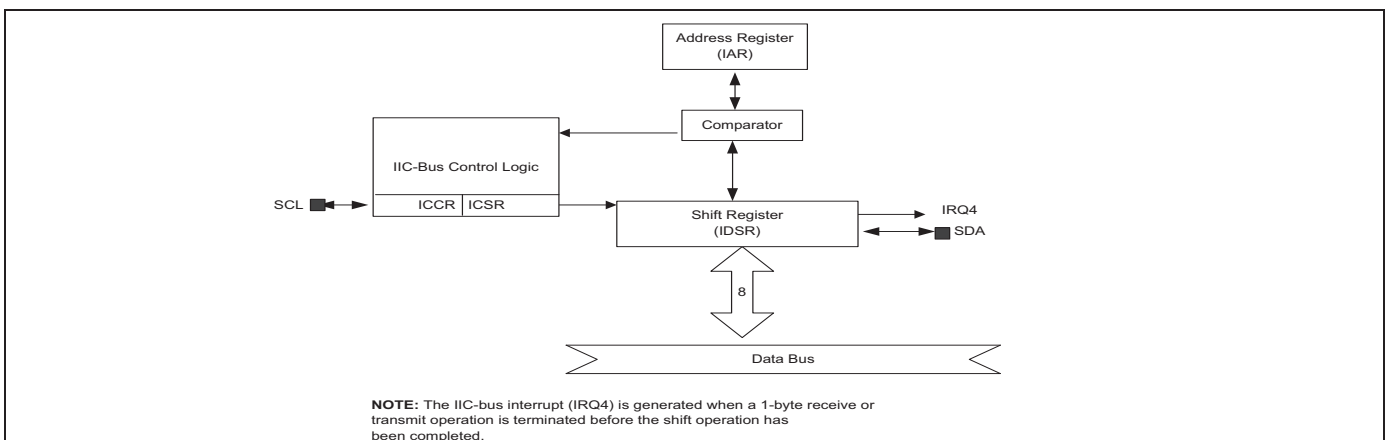
**Figure 18-3 Multi-Master IIC-Bus Tx/Rx Data Shift Register (IDSR)**

### 18.1.4 Multi-Master IIC-Bus Address Register

The address register for the IIC-bus interface (IAR) is located at address 0FH, Page 8. It is used to store a latched 7-bit slave address. This address is mapped to IAR.7-IAR.1; bit 0 is not used (Refer to [Figure 18-4](#) for more information).

The latched slave address is compared to the next received slave address. If a match condition is detected, and if the latched value is 0000000B, a general call status is detected.

[Figure 18-4](#) illustrates the multi-master IIC-bus address register.



**Figure 18-4 Multi-Master IIC-Bus Address Register (IAR)**

### 18.2 Block Diagram

Figure 18-5 illustrates the block diagram of IIC-bus.

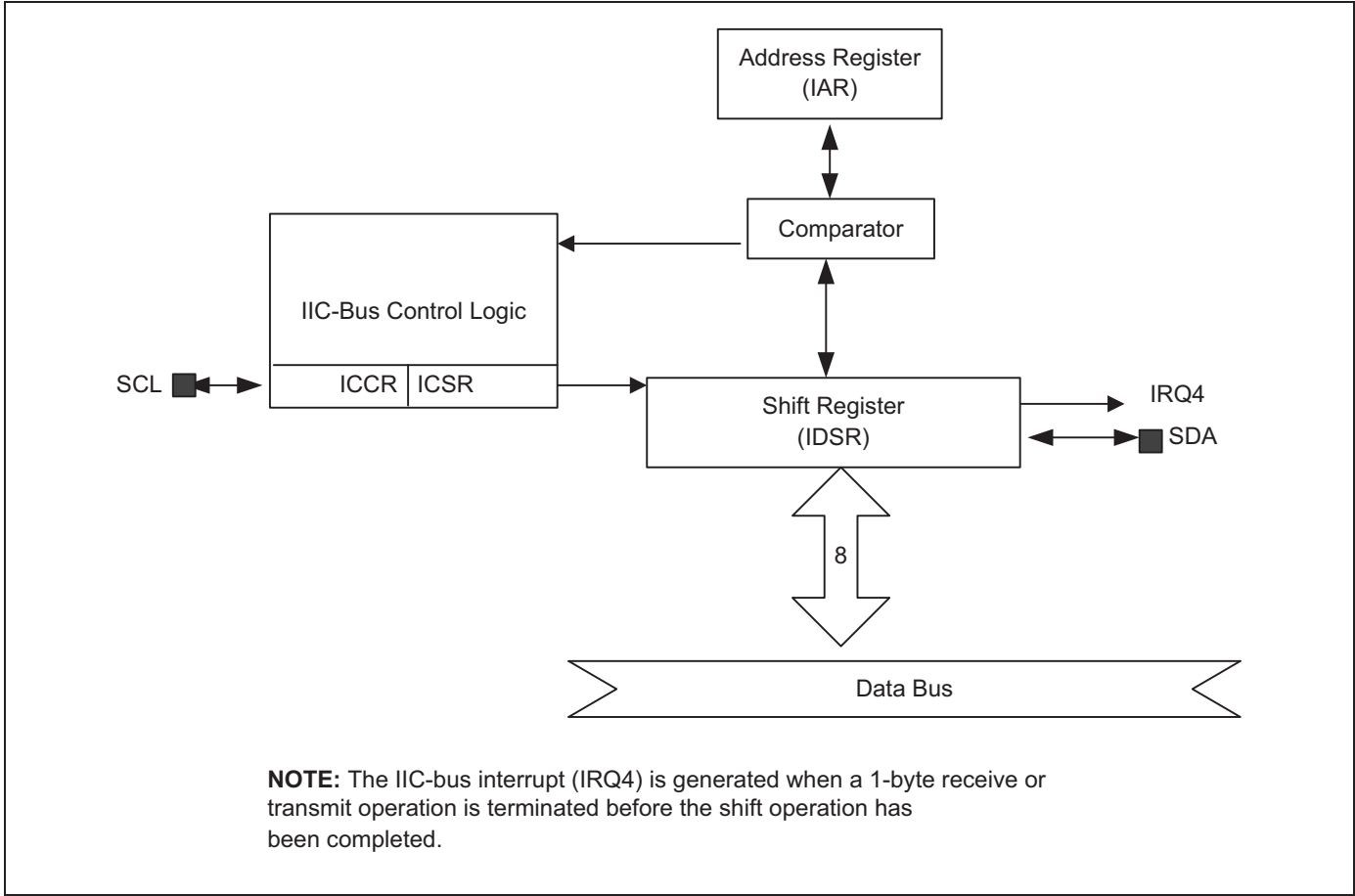


Figure 18-5 IIC-Bus Block Diagram

## 18.3 The IIC-Bus Interface

The S3F8S19/F8S15 IIC-bus interface has four operating modes:

- Master transmitter mode
- Master receive mode
- Slave transmitter mode
- Slave receive mode

Functional relationships between these operating modes are described in these sections.

## 18.4 Start and Stop Conditions

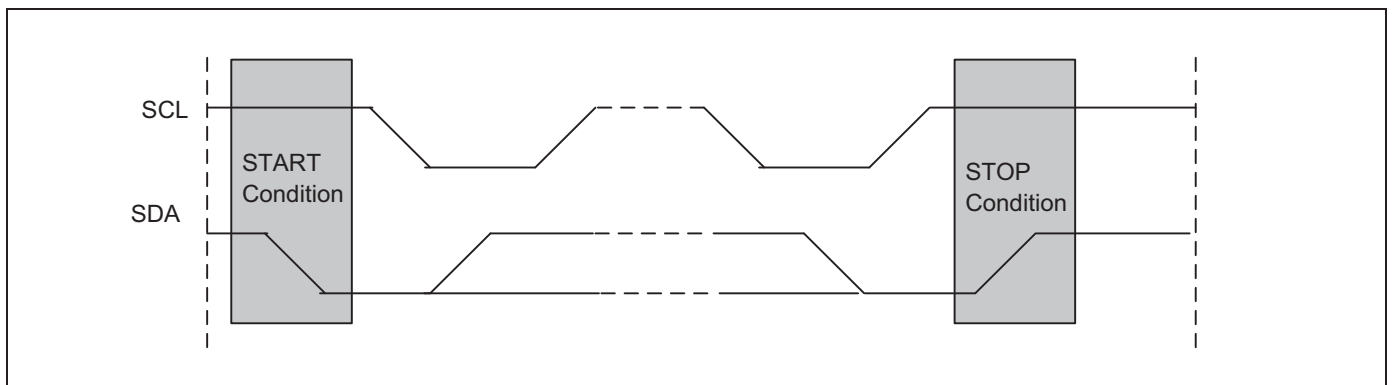
When the IIC-bus interface is inactive, it is in slave mode. Therefore, the interface is always in slave mode when a start condition is detected on the SDA line. (A start condition is a High-to-Low transition of the SDA line while the clock signal, SCL, is High level.) When the interface enters master mode, it initiates a data transfer and generates the SCL signal.

A start condition initiates a 1 byte serial data transfer over the SDA line and a stop condition ends the transfer. (A stop condition is a Low-to-High transition of the SDA line while SCL is High level.) Start and stop conditions are always generated by the master. The IIC-bus is "busy" when a start condition is generated. After a few clocks, a stop condition is generated; the IIC-bus is again "free".

When a master initiates a start condition, it sends its slave address onto the bus. The address byte consists of a 7-bit address and a 1-bit transfer direction indicator (that is, write or read). If bit 8 is "0", a transmit operation (write) is indicated; if bit 8 is "1", a request for data (read) is indicated.

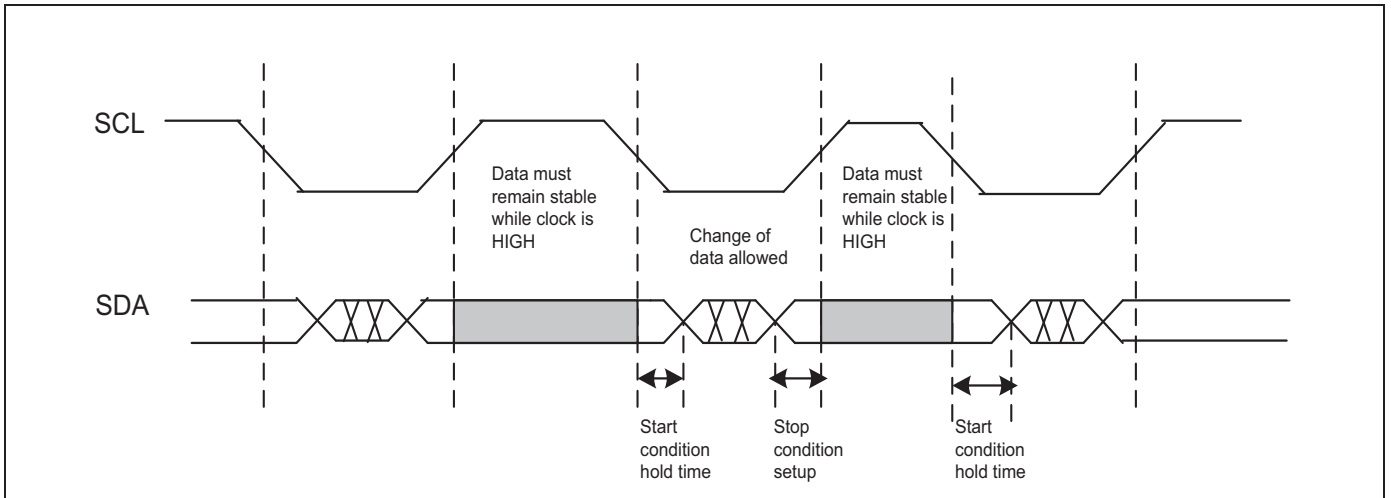
The master ends the indicated transfer operation by transmitting a stop condition. If the master wants to continue sending data over the bus, it can generate another slave address and another start condition. In this way, you can perform read write operations in various formats.

[Figure 18-6](#) illustrates the start and stop conditions.



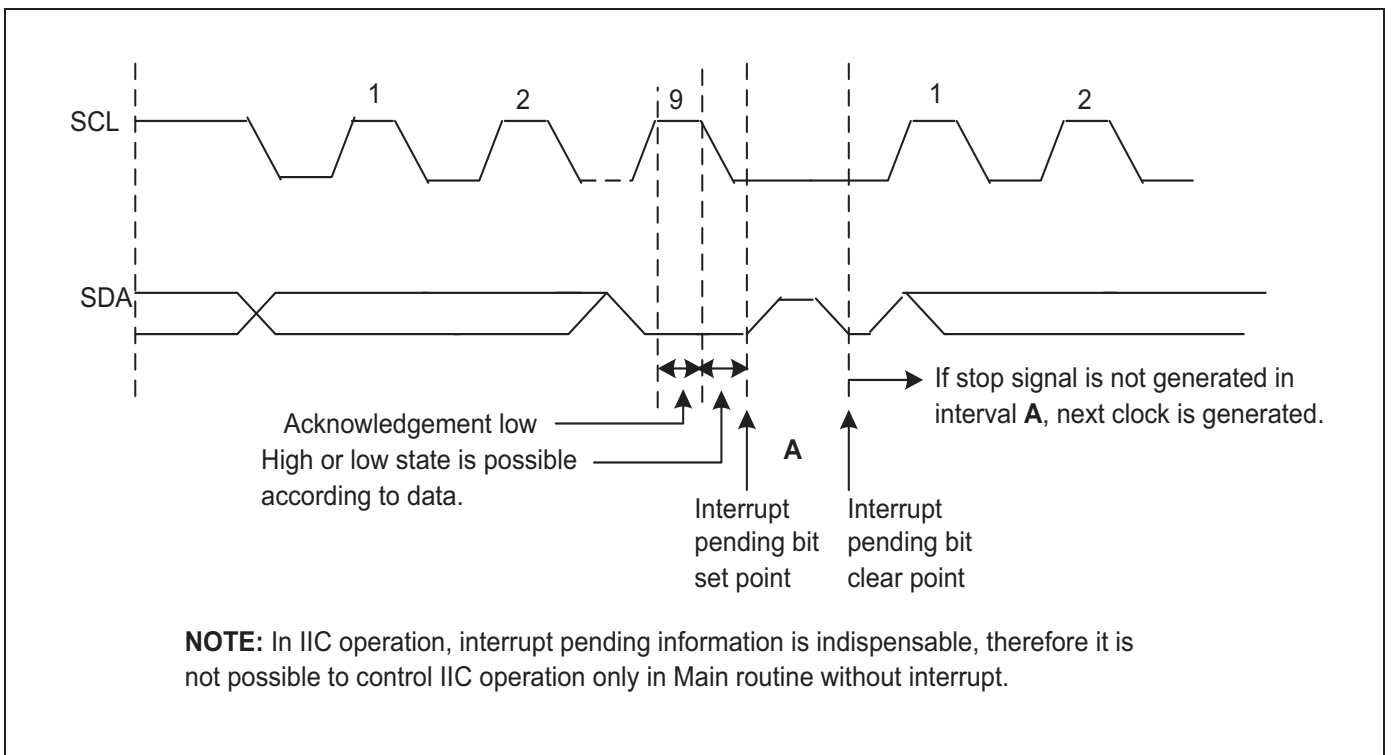
**Figure 18-6 Start and Stop Conditions**

Figure 18-7 illustrates the input data protocol.



**Figure 18-7 Input Data Protocol**

Figure 18-8 illustrates the interrupt pending information.



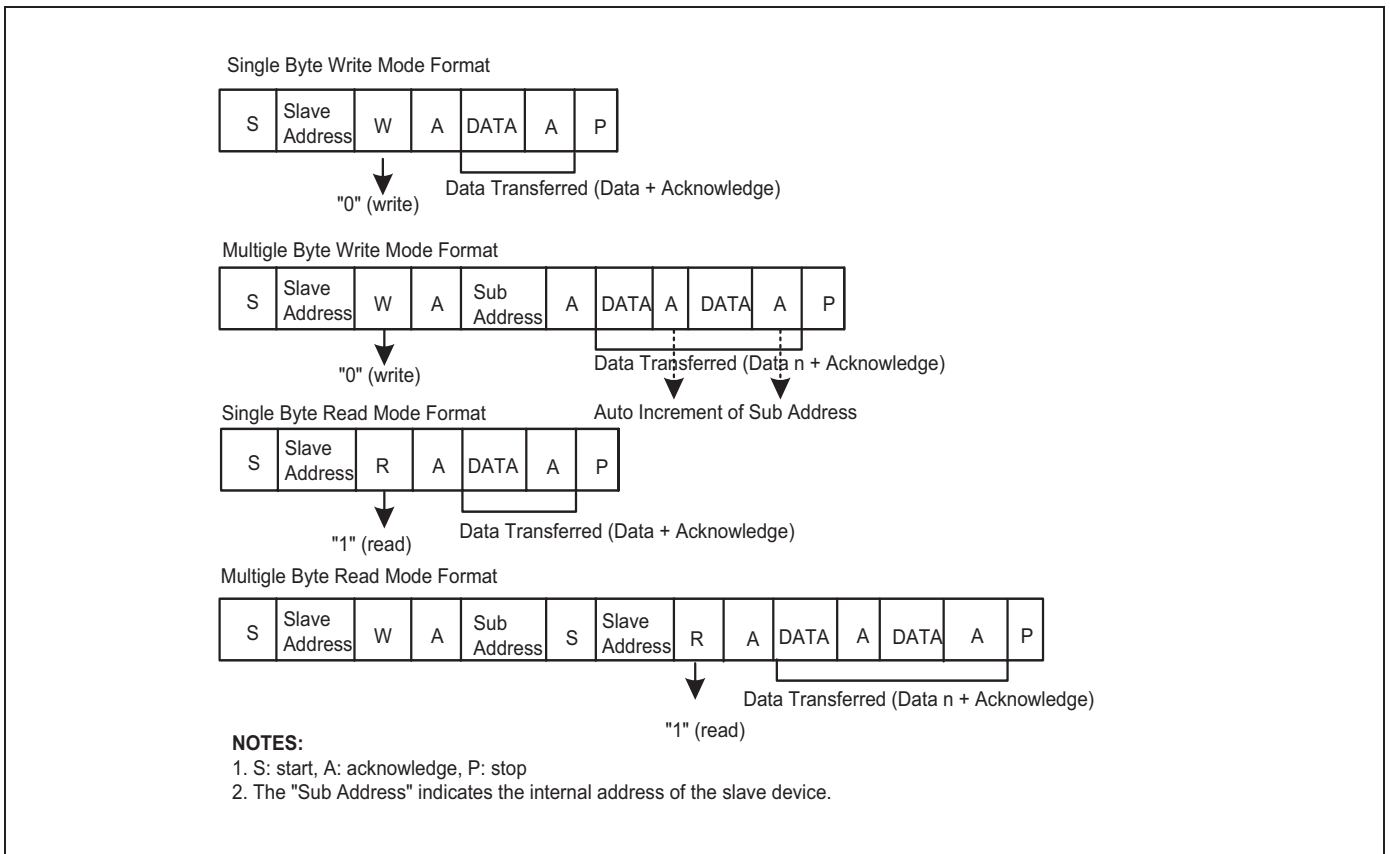
**Figure 18-8 Interrupt Pending Information**



## 18.5 Data Transfer Formats

Every byte that you put on the SDA line must be 8 bits in length. The number of bytes which you can transmit per transfer is unlimited. The first byte following a start condition is the address byte. The master transmits this address byte when the IIC-bus is operating in master mode. Each byte must be followed by an acknowledge (ACK) bit. Serial data and addresses are always sent MSB first.

*Figure 18-9* illustrates the IIC-bus interface data formats.



**Figure 18-9 IIC-Bus Interface Data Formats**

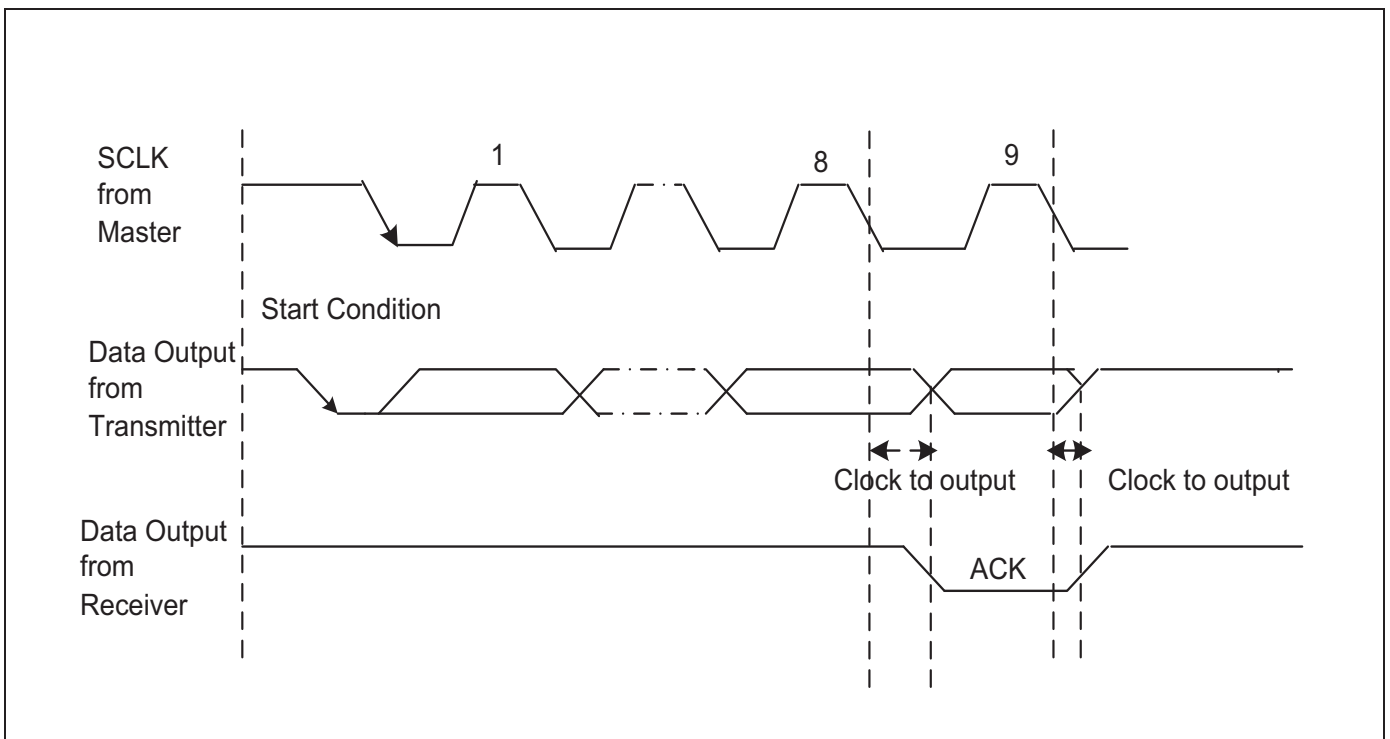
## 18.6 ACK Signal Transmission

To complete a 1 byte transfer operation, the receiver should send an ACK bit to the transmitter. The ACK pulse occurs at the ninth clock of the SCL line (eight clocks are required to complete the one-byte transfer). The clock pulse required for the transmission of the ACK bit is always generated by the master.

The transmitter releases the SDA line (that is, it sends the SDA line High) when the ACK clock pulse is received. The receiver should drive the SDA line Low during the ACK clock pulse so that SDA is Low during the High period of the ninth SCL pulse.

You can enable and disable the ACK bit transmit function by software (ICCR.7). However, the ACK pulse on the ninth clock of SCL is required to complete a 1 byte data transfer operation.

[Figure 18-10](#) illustrates the acknowledge response from receiver.



**Figure 18-10 Acknowledge Response from Receiver**

Figure 18-11 illustrates the write operation sequence.

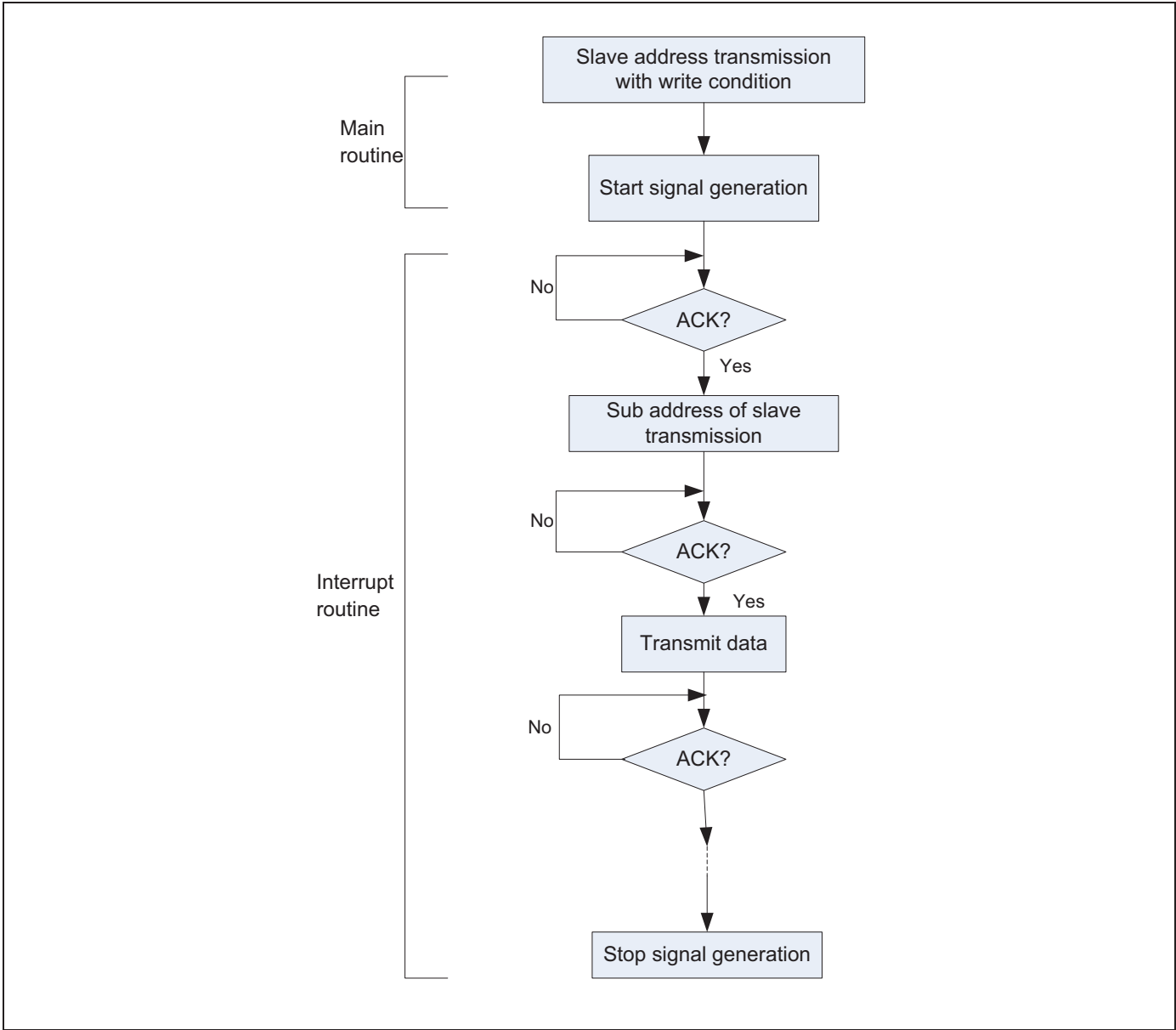


Figure 18-11 Write Operation Sequence

Figure 18-12 illustrates the read operation sequence.

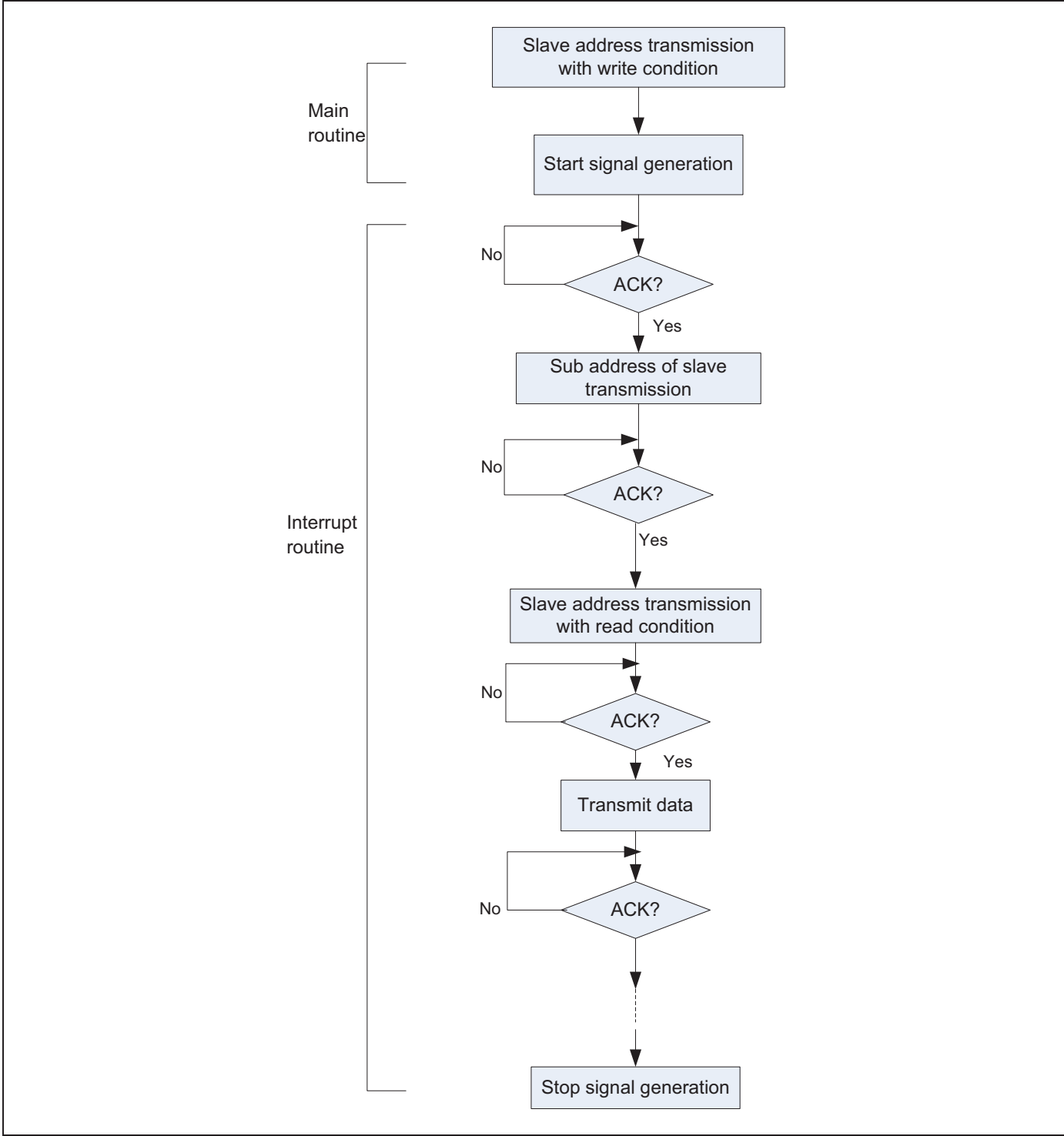


Figure 18-12 Read Operation Sequence

## 18.7 Read-Write Operations

When operating in transmitter mode, the IIC-bus interface interrupt routine waits for the master (the S3F8S19/F8S15) to write a data byte into the IIC-bus data shift register (IDSR). To perform this, it holds the SCL line Low prior to transmission.

In receive mode, the IIC-bus interface waits for the master to read the byte from the IIC-bus data shift register (IDSR). It performs this by holding the SCL line Low after the complete reception of a data byte.

## 18.8 Bus Arbitration Procedures

Arbitration takes place on the SDA line to prevent contention on the bus between two masters. If a master with a SDA High level detects another master with an SDA active Low level, it will not initiate a data transfer because the current level on the bus does not correspond to its own level. The master that loses the arbitration can generate SCL pulses only until the end of the last-transmitted data byte. The arbitration procedure can continue while data continues to be transferred over the bus.

The first stage of arbitration is the comparison of address bits. If a master loses the arbitration during the addressing stage of a data transfer, it is possible that the master that won the arbitration attempts address the master that lost. In this case, the losing master should immediately switch to slave receiver mode.

## 18.9 Abort Conditions

If a slave receiver does not acknowledge the slave address, it should hold the level of the SDA line High. This signals the master to generate a stop condition and to abort the transfer.

If a master receiver involves in the aborted transfer, it should also signal the end of the slave transmit operation. It performs this by not generating an ACK after the last data byte received from the slave. The slave transmitter must then release the SDA to allow a master to generate a stop condition.

## 18.10 Configuring the IIC-Bus

To control the frequency of the serial clock (SCL), you should program the 4-bit pre-scalar value in the ICCR register. The IIC-bus interface address is stored in IAR. By default, the IIC-bus interface address is an unknown value.

# 19

## UART 0

### 19.1 Overview

The UART 0 block has a full-duplex serial port with programmable operating modes:

There are one synchronous mode and three Universal Asynchronous Receiver/Transmitter (UART) modes:

- Serial I/O with baud rate of  $f_U / (16 \times (\text{BRDATA0} + 1))$
- 8-bit UART mode: variable baud rate
- 9-bit UART mode:  $f_U / 16$
- 9-bit UART mode: variable baud rate

You can access both UART 0 receive and transmit buffers through the data register, UDATA0 in set 1, bank 0 at address F0H. Writing to the UART data register loads the transmit buffer; reading the UART 0 data register accesses a physically separate receive buffer.

When accessing a receive data buffer (shift register), reception of the next byte can begin before CPU reads the previously received byte from the receive register. However, if the first byte has not been read by the time the next byte has been completely received, one of the bytes will be lost.

In all operating modes, transmission is started when any instruction (usually a write operation) uses the UDATA0 register as its destination address. In mode 0, serial data reception starts when they receive interrupt pending bit (UART0CONH.0) is "0" and the receive enable bit (UART0CONH.4) is "1". In modes 1, 2 and 3, reception starts whenever an incoming start bit ("0") is received and the receive enable bit (UART0CONH.4) is set to "1".

## 19.2 Programming Procedure

To program the UART 0 modules, the basic steps are:

1. Configure P4.7 and P4.6 to alternative function (RxD0 (P4.7), TxD0 (P4.6)) for UART 0 module by setting the P4CONH register to appropriately value.
2. Load an 8-bit value to the UART0CONH/L control register to properly configure the UART 0 I/O module.
3. For interrupt generation, set the UART 0 I/O interrupt enable bit (UART0CONH.1 or UART0CONL.1) to "1".
4. When you transmit data to the UART 0 buffer, write data to UDATA0, the shift operation starts.
5. When the shift operation (receive/transmit) completes, CPU sets UART 0 pending bit (UART0CONH.0 or UART0CONL.0) to "1" and generates an UART 0 interrupt request.

### 19.2.1 UART 0 High Byte Control Register (UART0CONH)

The control register for the UART 0 is called UART0CONH in page 8 at address 00H.

The control functions of UART0CONH are:

- Select operating mode and baud rate Supports multiprocessor communication and interrupt control  
Enables/disables serial receive control Ninth data bit location for transmit and receive operations (modes 2 and 3 only)
- UART 0 receive interrupt control

A reset clears the UART0CONH value to "00H". Therefore, if you want to use UART 0 module, you should write appropriate value to UART0CONH.

### 19.2.2 UART 0 Low Byte Control Register

The control register for the UART 0 is called UART0CONL located in page 8 at address 01H.

The control functions of UART0CONL are:

- Selects UART 0 transmit and receive parity-bit
- Selects UART 0 clock
- UART 0 transmit interrupt control

A reset clears the UART0CONL value to "00H". Therefore, if you want to use UART 0 module, you should write appropriate value to UART0CONL.

Figure 19-1 illustrates the UART 0 high byte control register.

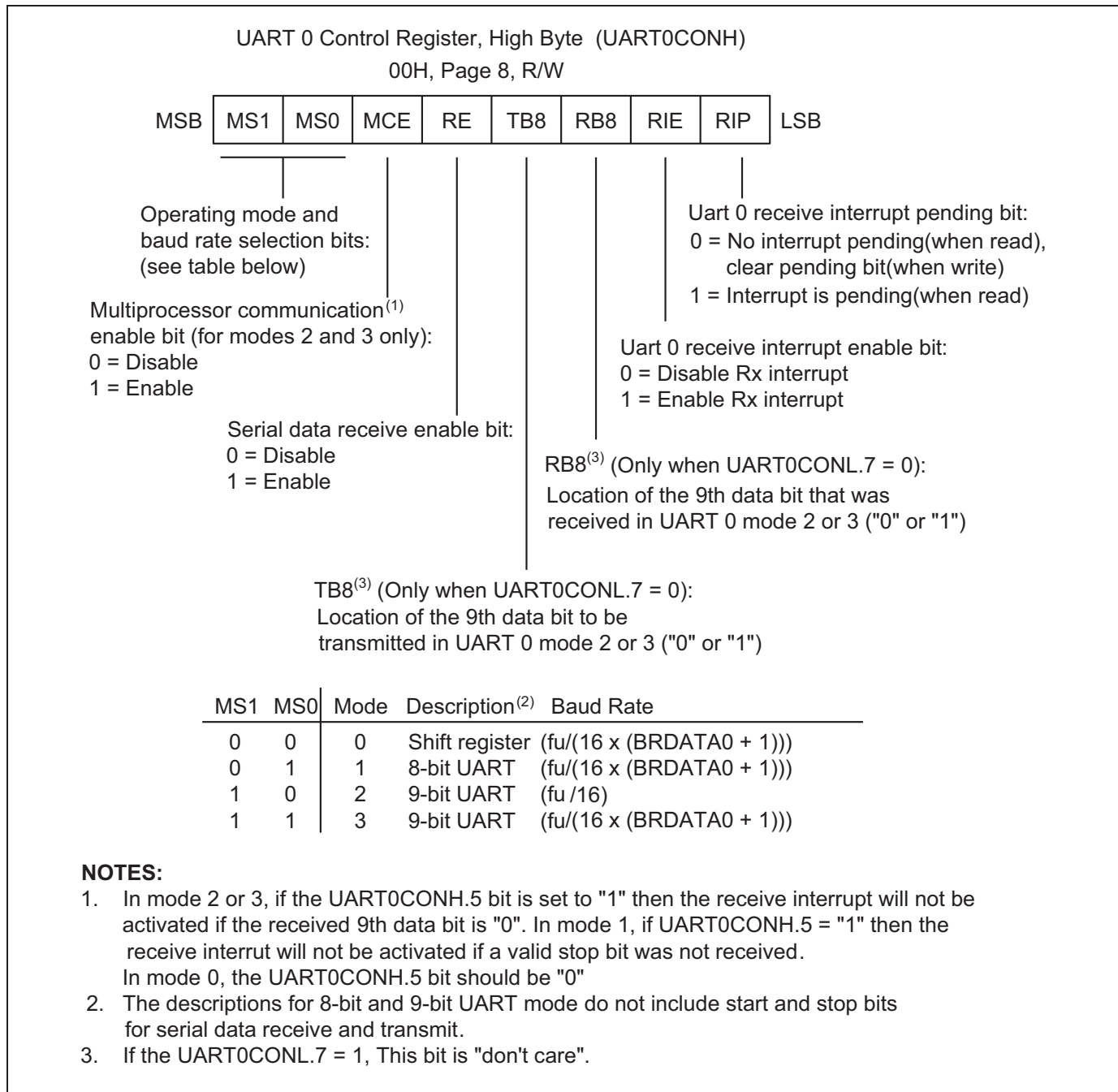
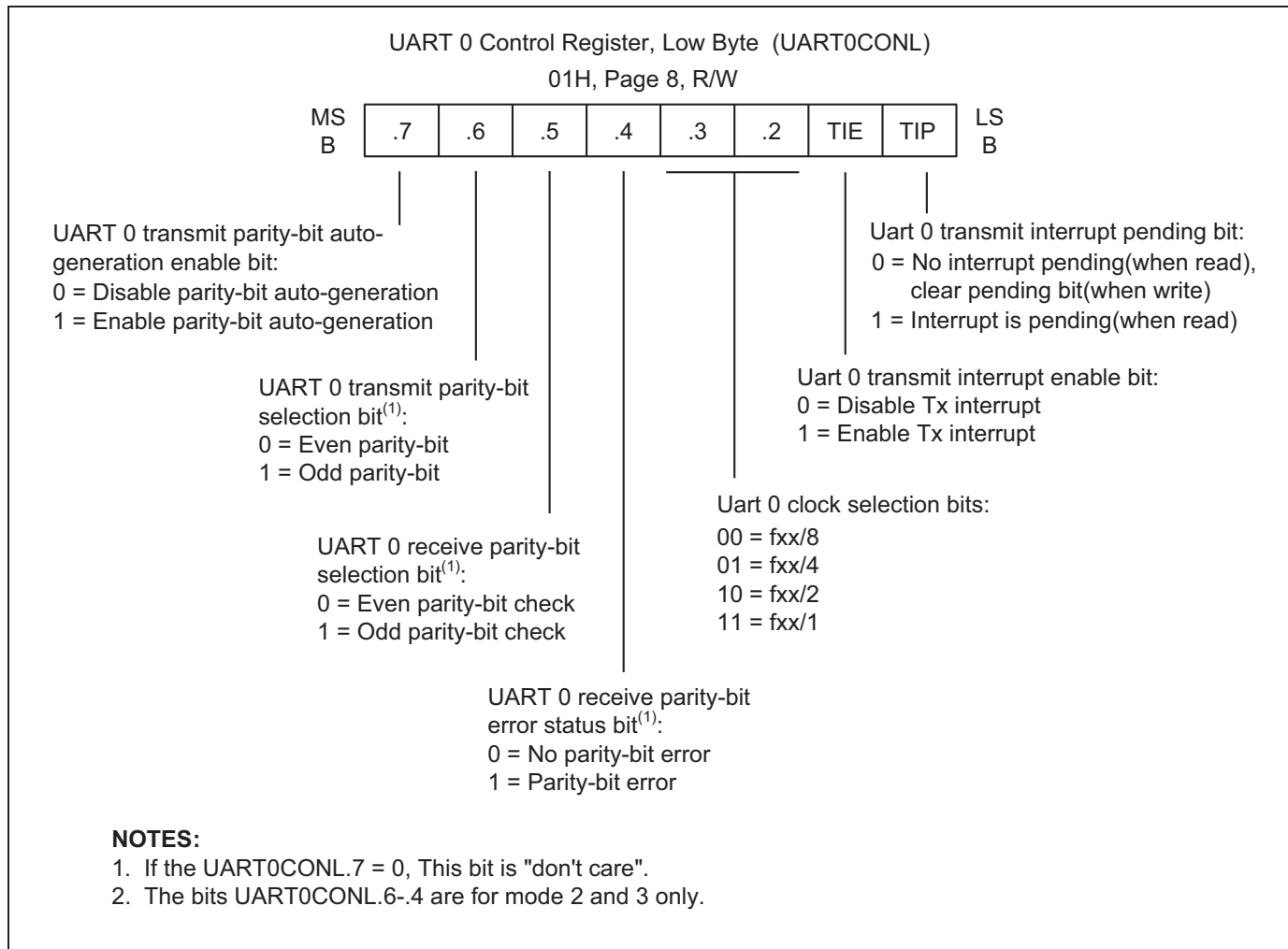


Figure 19-1 UART 0 High Byte Control Register (UART0CONH)



Figure 19-2 illustrates the UART 0 low byte control register.



**Figure 19-2 UART 0 Low Byte Control Register (UART0CONL)**



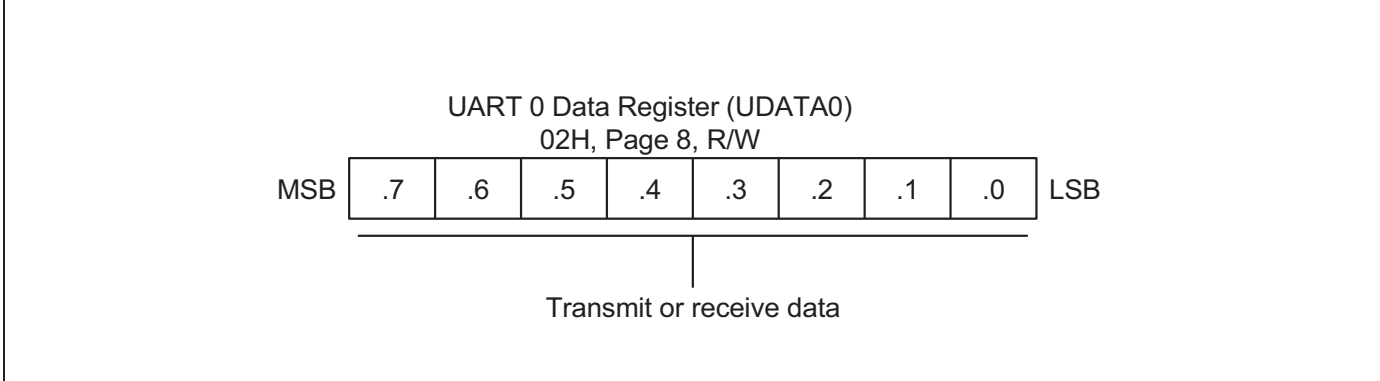
**19.2.3 UART 0 Interrupt Pending Bits**

In mode 0, the receive interrupt pending bit UART0CONH.0 is set to "1" when the 8th receive data bit has been shifted. In mode 1, the UART0CONH.0 bit is set to "1" at the halfway point of the shift time of stop bit. In mode 2 or 3, the UART0CONH.0 bit is set to "1" at the halfway point of the shift time of RB8 bit. When the CPU acknowledges the receive interrupt pending condition, the UART0CONH.0 bit must then be cleared by software in the interrupt service routine.

In mode 0, the transmit interrupt pending bit UART0CONL.0 is set to "1" when the 8th transmit data bit has been shifted. In mode 1, 2 or 3, the UART0CONL.0 bit is set at the start of the stop bit. When the CPU acknowledges the transmit interrupt pending condition, the UART0CONL.0 bit must then be cleared by software in the interrupt service routine.

**19.2.4 UART 0 Data Register**

*Figure 19-3* illustrates the UART 0 data register (UDATA0).

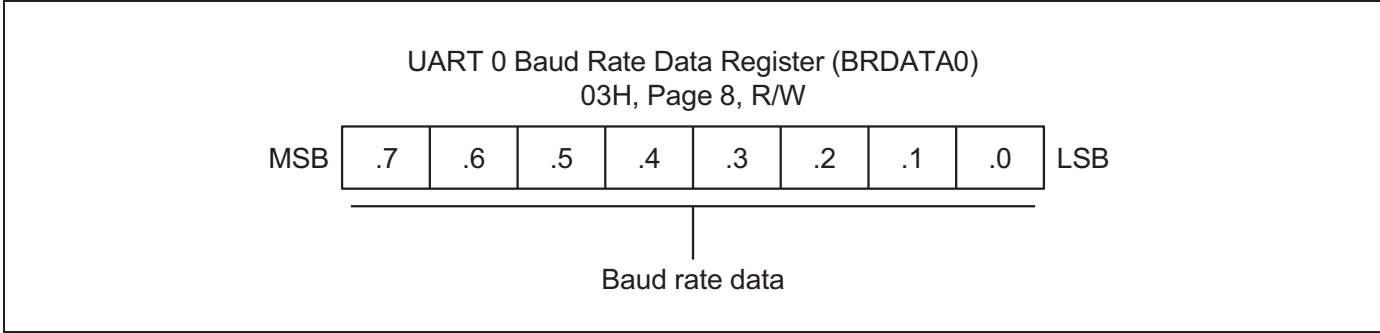


**Figure 19-3 UART 0 Data Register (UDATA0)**

**19.2.5 UART 0 Baud Rate Data Register**

The value stored in the UART 0 baud rate register, BRDATA0, lets you determine the UART 0 clock rate (baud rate).

*Figure 19-4* illustrates the UART 0 baud rate data register.



**Figure 19-4 UART 0 Baud Rate Data Register (BRDATA0)**

## 19.3 Baud Rate Calculations

This section includes:

- Mode 0 baud rate calculation
- Mode 2 baud rate calculation
- Mode 1 and 3 baud rate calculation

### 19.3.1 Mode 0 Baud Rate Calculation

In mode 0, the baud rate is determined by the UART 0 baud rate data register, BRDATA0 in Page 8 at address 03H: Mode 0 baud rate =  $f_U / (16 \times (BRDATA0 + 1))$ .

### 19.3.2 Mode 2 Baud Rate Calculation

The baud rate in mode 2 is fixed at the  $f_U$  clock frequency divided by 16: Mode 2 baud rate =  $f_U / 16$

### 19.3.3 Mode 1 and 3 Baud Rate Calculation

In modes 1 and 3, the baud rate is determined by the UART 0 baud rate data register, BRDATA0 in Page 8 at address 03H: Mode 1 and 3 baud rate =  $f_U / (16 \times (BRDATA0 + 1))$

[Table 19-1](#) lists the commonly used baud rates generated by BRDATA0.

**Table 19-1 Commonly Used Baud Rates Generated by BRDATA0**

| Mode                       | Baud Rate  | UART Clock ( $f_U$ ) | BRDATA0 |             |
|----------------------------|------------|----------------------|---------|-------------|
|                            |            |                      | Decimal | Hexadecimal |
| Mode 2                     | 0.5 MHz    | 8 MHz                | x       | x           |
| Mode 0<br>Mode 1<br>Mode 3 | 230,400 Hz | 11.0592 MHz          | 02      | 02H         |
|                            | 115,200 Hz | 11.0592 MHz          | 05      | 05H         |
|                            | 57,600 Hz  | 11.0592 MHz          | 11      | 0BH         |
|                            | 38,400 Hz  | 11.0592 MHz          | 17      | 11H         |
|                            | 19,200 Hz  | 11.0592 MHz          | 35      | 23H         |
|                            | 9,600 Hz   | 11.0592 MHz          | 71      | 47H         |
|                            | 4,800 Hz   | 11.0592 MHz          | 143     | 8FH         |
|                            | 62,500 Hz  | 10 MHz               | 09      | 09H         |
|                            | 9,615 Hz   | 10 MHz               | 64      | 40H         |
|                            | 38,461 Hz  | 8 MHz                | 12      | 0CH         |
|                            | 12,500 Hz  | 8 MHz                | 39      | 27H         |
|                            | 19,230 Hz  | 4 MHz                | 12      | 0CH         |
| 9,615 Hz                   | 4 MHz      | 25                   | 19H     |             |

### 19.4 Block Diagram

Figure 19-5 illustrates the functional block diagram of UART 0.

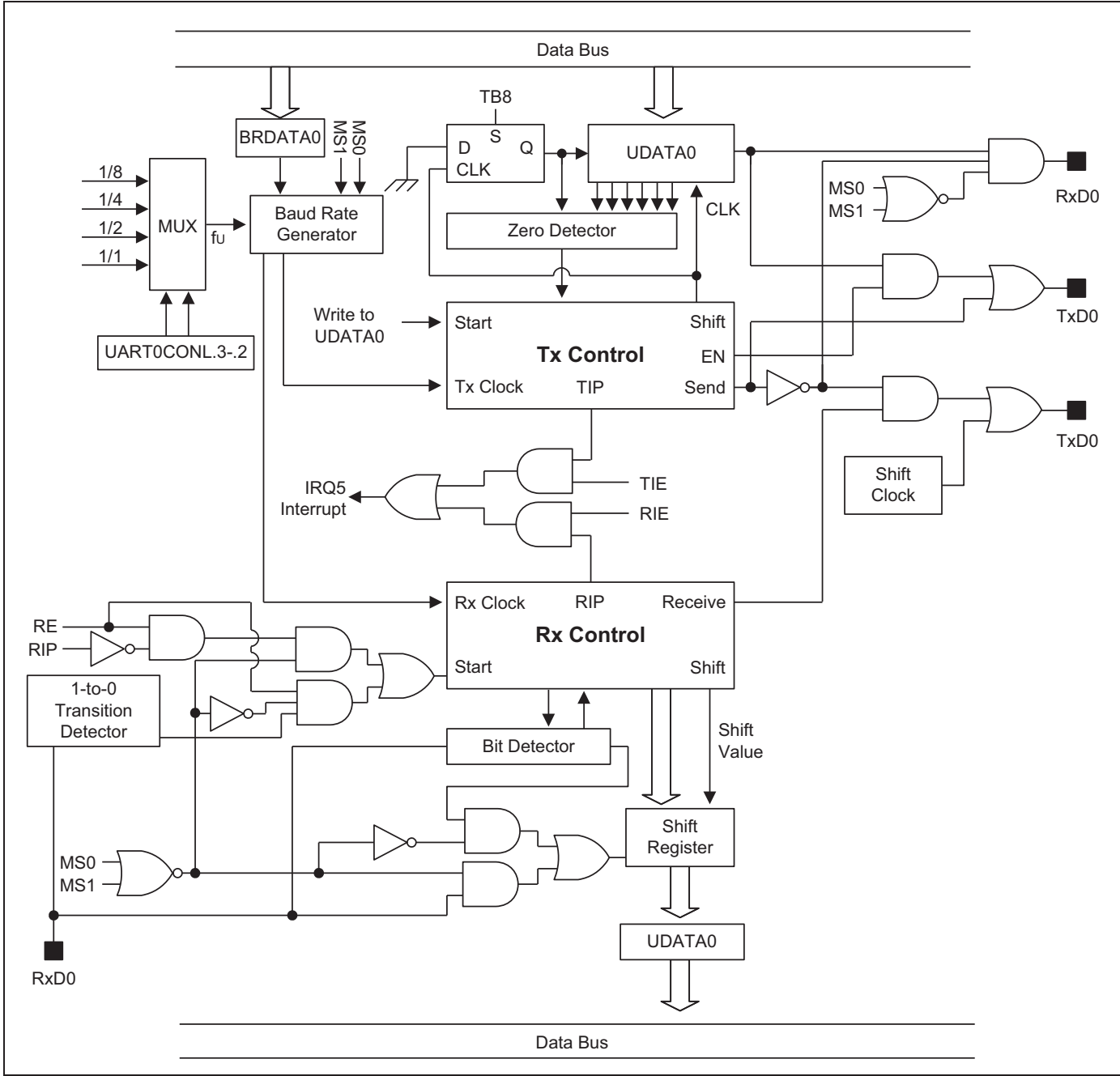


Figure 19-5 UART 0 Functional Block Diagram

## 19.5 UART 0 Mode 0 Function Description

In mode 0, UART 0 is input and output through the RxD0 (P4.7) pin and TxD0 (P4.6) pin outputs the shift clock. Data is transmitted or received in 8-bit units only. The LSB of the 8-bit value is transmitted (or received) first.

### 19.5.1 Mode 0 Transmit Procedure

The steps of Mode 0 transmit procedure are:

1. Select the UART 0 clock, UART0CONL.3 and .2.
2. Set the UART 0 transmit parity-bit auto generation enable or disable bit (UART0CONL.7).
3. Select mode 0 by setting UART0CONH.7 and .6 to "00B".
4. Write transmission data to the shift register UDATA0 (F0H, set 1, bank 0) to start the transmission operation.

### 19.5.2 Mode 0 Receive Procedure

The steps of Mode 0 receive procedure are:

1. Select the UART 0 clock, UART0CONL.3 and .2.
2. Set the UART 0 transmit parity-bit auto generation enable or disable bit (UART0CONL.7).
3. Select mode 0 by setting UART0CONH.7 and .6 to "00B".
4. Clear the receive interrupt pending bit (UART0CONH.0) by writing a "0" to UART0CONH.0.
5. Set the UART 0 receive enable bit (UART0CONH.4) to "1".
6. The shift clock will now be output to the TxD0 (P4.6) pin and will read the data at the RxD0 (P4.7) pin. A UART 0 receive interrupt occurs when UART0CONH.1 is set to "1".

Figure 19-6 illustrates the timing diagram for serial port Mode 0 operation.

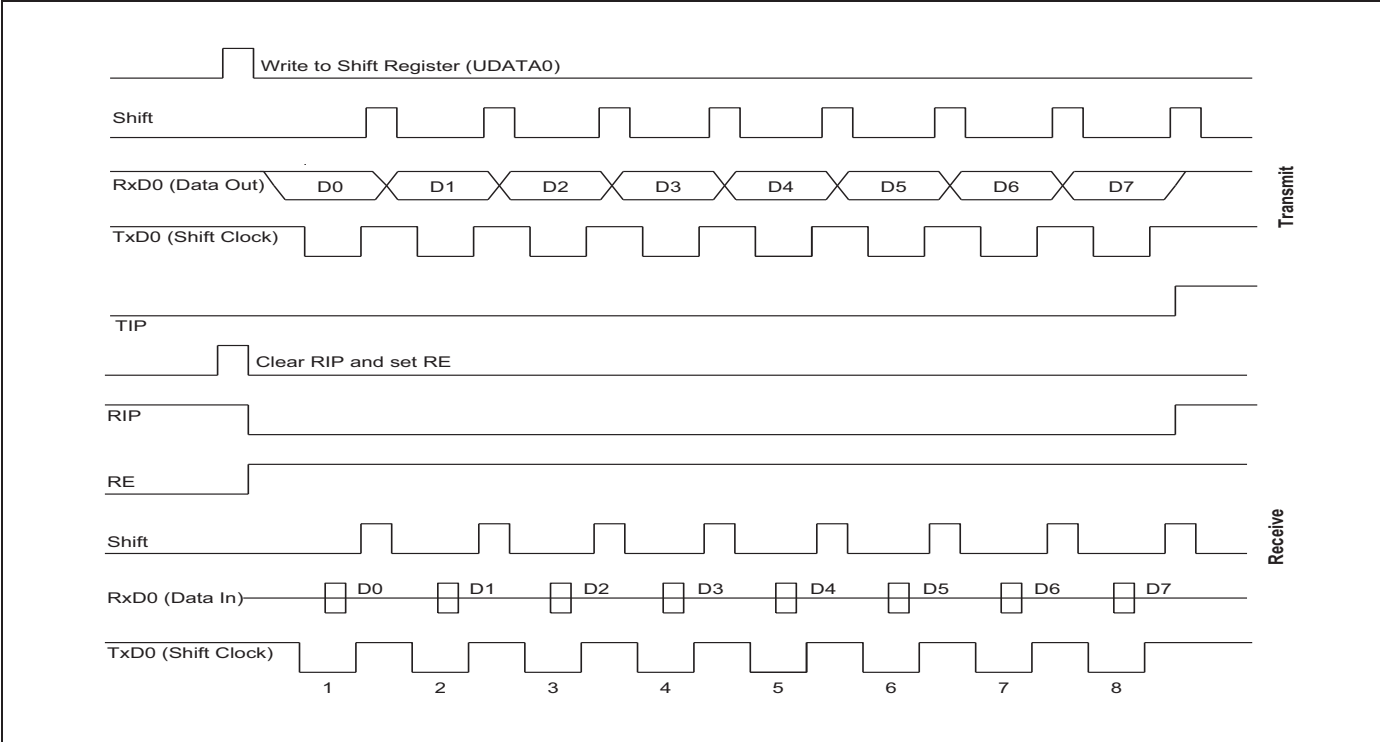


Figure 19-6 Timing Diagram for Serial Port Mode 0 Operation

## 19.6 Serial Port Mode 1 Function Description

In mode 1, 10 bits are transmitted through the TxD0 (P4.6) pin or received through the RxD0 (P4.7) pin.

The three components of each data frame are:

- Start bit ("0")
- 8 data bits (LSB first)
- Stop bit ("1")

The baud rate for mode 1 is variable.

### 19.6.1 Mode 1 Transmit Procedure

The steps of Mode 1 transmit procedure are:

1. Select the UART 0 clock, UART0CONL.3 and .2.
2. Set the UART 0 transmit parity-bit auto generation enable or disable bit (UART0CONL.7).
3. Select the baud rate that BRDATA0 generates.
4. Select mode 1 (8-bit UART) by setting UART0CONH bits 7 and 6 to "01B".
5. Write transmission data to the shift register UDATA0 (F0H, set 1, bank 0). The start and stop bits are generated automatically by hardware.

### 19.6.2 Mode 1 Receive Procedure

The steps of Mode 1 receive procedure are:

1. Select the UART 0 clock, UART0CONL.3 and .2.
2. Set the UART 0 transmit parity-bit auto generation enable or disable bit (UART0CONL.7).
3. Select the baud rate that BRDATA0 generates.
4. Select mode 1 and set the RE (Receive Enable) bit in the UART0CONH register to "1".
5. The start bit low ("0") condition at the RxD0 (P4.7) pin will cause the UART 0 module to start the serial data receive operation.

Figure 19-7 illustrates the timing diagram for serial port Mode 1 operation.

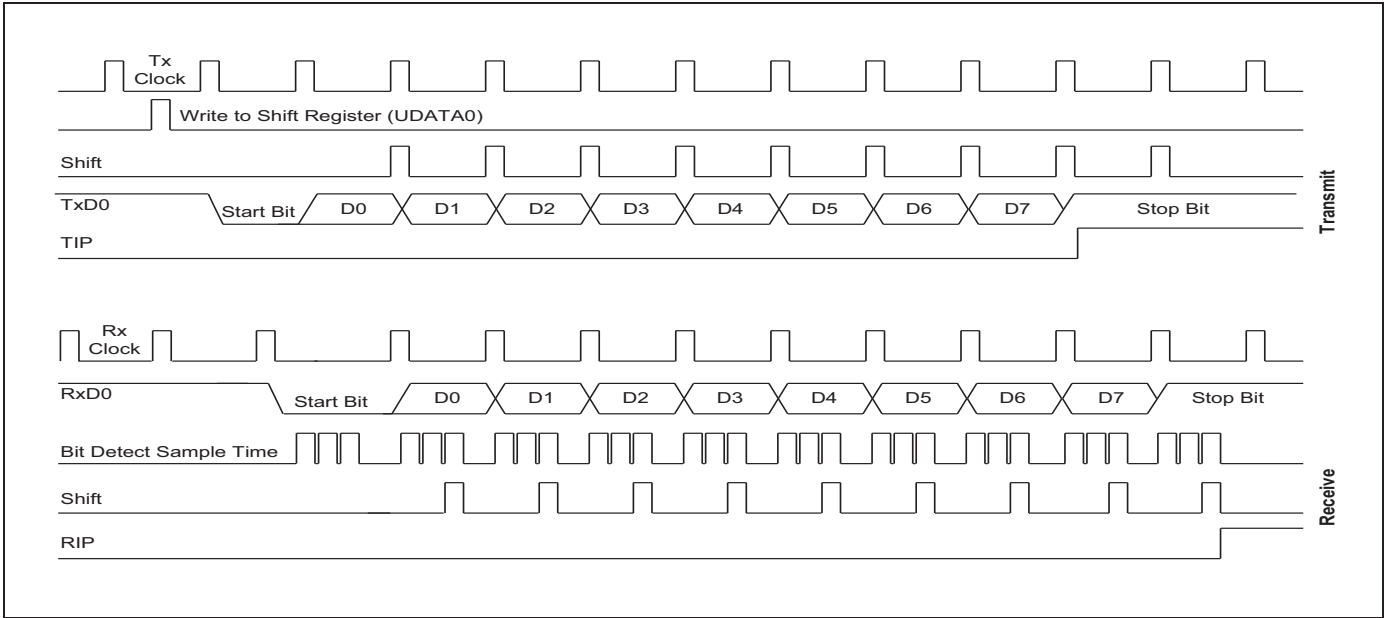


Figure 19-7 Timing Diagram for Serial Port Mode 1 Operation



## 19.7 Serial Port Mode 2 Function Description

In mode 2, 11 bits are transmitted through the TxD0 (P4.6) pin or received through the RxD0 (P4.7) pin.

The four components of each data frame are:

- Start bit ("0")
- 8 data bits (LSB first)
- Programmable 9<sup>th</sup> data bit
- Stop bit ("1")

The 9<sup>th</sup> data bit to be transmitted can be assigned a value of "0" or "1" by writing the TB8 bit (UART0CONH.3). When receiving, the 9<sup>th</sup> data bit that it receives is written to the RB8 bit (UART0CONH.2), while the stop bit is ignored. The baud rate for mode 2 is  $f_U/16$  clock frequency.

### 19.7.1 Mode 2 Transmit Procedure

The steps for Mode 2 transmit procedure are:

1. Select the UART 0 clock, UART0CONL.3 and .2.
2. Set the UART 0 transmit parity-bit auto generation enable or disable bit (UART0CONL.7).
3. Select mode 2 (9-bit UART) by setting UART0CONH bits 7 and 6 to "10B". Also, select the 9<sup>th</sup> data bit to be transmitted by writing TB8 to "0" or "1".
4. Write transmission data to the shift register, UDATA0 (F0H, set 1, bank 0), to start the transmit operation.

### 19.7.2 Mode 2 Receive Procedure

The steps for Mode 2 receive procedure are:

1. Select the UART 0 clock, UART0CONL.3 and .2.
2. Set the UART 0 transmit parity-bit auto generation enable or disable bit (UART0CONL.7).
3. Select mode 2 and set the receive enable bit (RE) bit in the UART0CONH register to "1".
4. The receive operation starts when the signal at the RxD0 (P4.7) pin enters to low level.

Figure 19-8 illustrates the timing diagram for serial port Mode 2 operation.

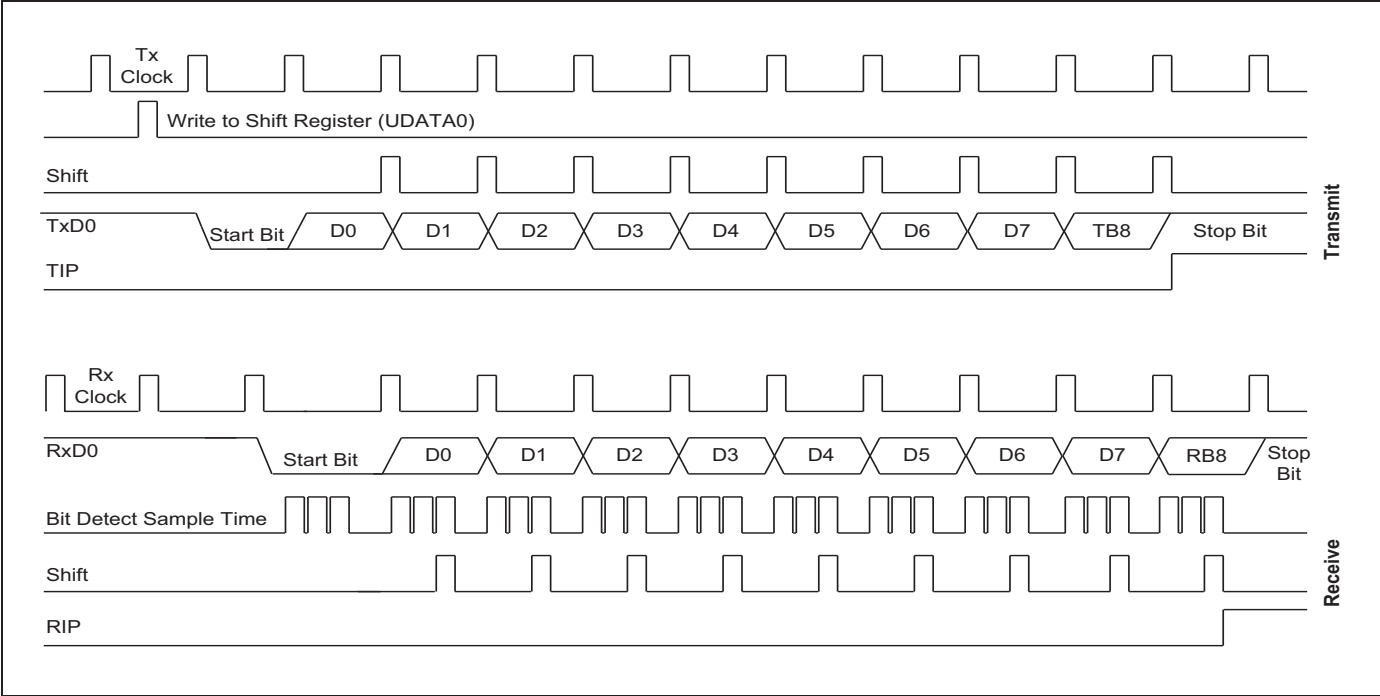


Figure 19-8 Timing Diagram for Serial Port Mode 2 Operation

## 19.8 Serial Port Mode 3 Function Description

In mode 3, 11 bits are transmitted through the TxD0 (P4.6) pin or received through the RxD0 (P4.7) pin. Mode 3 is identical to mode 2 except for baud rate, which is variable.

The four components of each data frame are:

- Start bit ("0")
- 8 data bits (LSB first)
- Programmable 9<sup>th</sup> data bit
- Stop bit ("1")

### 19.8.1 Mode 3 Transmit Procedure

The steps for Mode 3 transmit procedure are:

1. Select the UART 0 clock, UART0CONL.3 and .2.
2. Set the UART 0 transmit parity-bit auto generation enable or disable bit (UART0CONL.7).
3. Select mode 3 operation (9-bit UART) by setting UART0CONH bits 7 and 6 to "11B". Also, select the 9<sup>th</sup> data bit to be transmitted by writing UART0CONH.3 (TB8) to "0" or "1".
4. Write transmission data to the shift register, UDATA0 (F0H, set 1, bank 0), to start the transmit operation.

### 19.8.2 Mode 3 Receive Procedure

The steps for Mode 3 receive procedure are:

1. Select the UART 0 clock, UART0CONL.3 and .2.
2. Set the UART 0 transmit parity-bit auto generation enable or disable bit (UART0CONL.7).
3. Select mode 3 and set the RE (Receive Enable) bit in the UART0CONH register to "1".
4. The receive operation will be started when the signal at the RxD0 (P4.7) pin enters to low level.

Figure 19-9 illustrates the timing diagram for serial port Mode 3 operation.

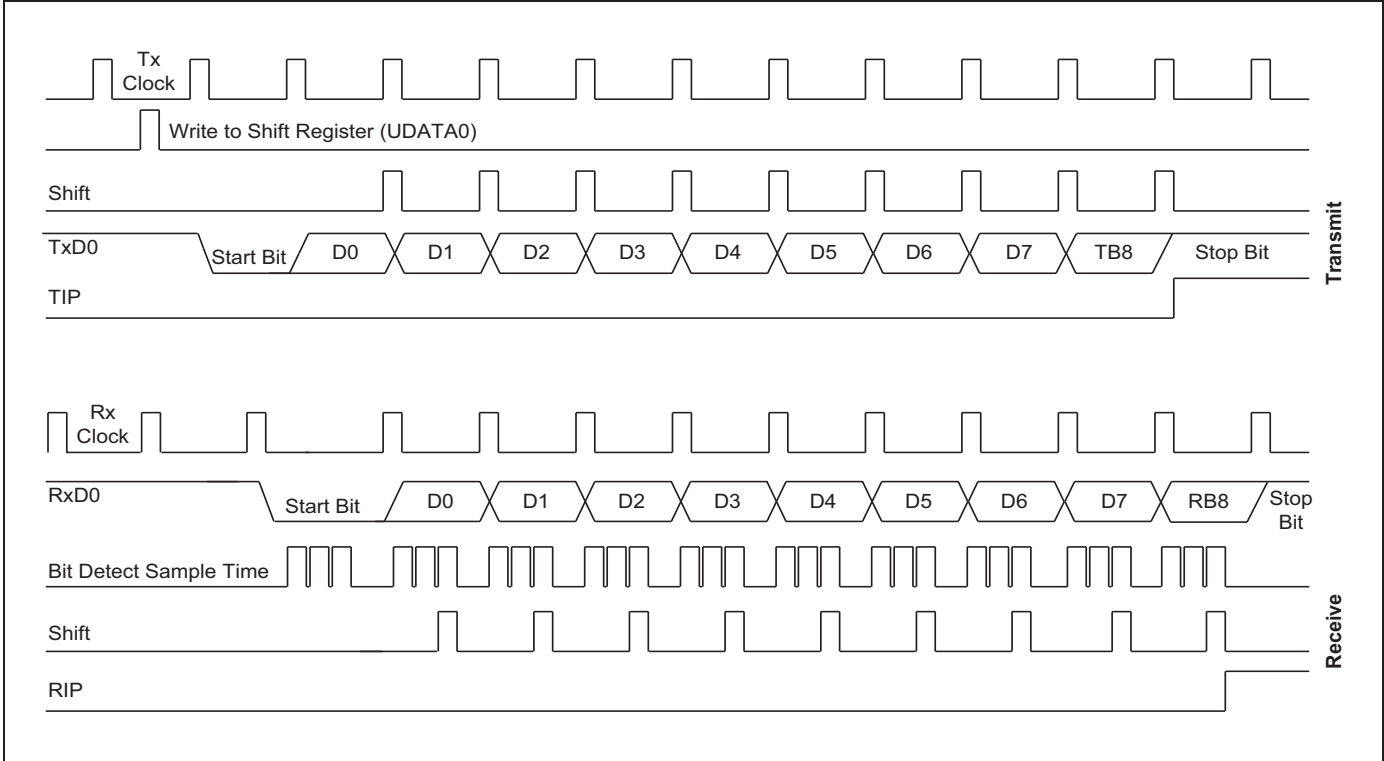


Figure 19-9 Timing Diagram for Serial Port Mode 3 Operation

## 19.9 Serial Communication for Multiprocessor Configurations

The S3F8-series multiprocessor communication feature enables a "master" S3F8S19/F8S15 to send a multiple-frame serial message to a "slave" device in a multi- S3F8S19/F8S15 configuration. It does this without interrupting other slave devices that may be on the same serial line.

This feature can be used only in UART modes 2 or 3. In these modes, 2 and 3, 9 data bits are received. The 9<sup>th</sup> bit value is written to RB8 (UART0CONH.2). The data receive operation is concluded with a stop bit. You can program this function so that when the stop bit is received, the serial interrupt will be generated only if RB8 = "1".

To enable this feature, you should set the MCE bit in the UART0CONH register. When the MCE bit is "1", the serial data frames that are received with the ninth bit = "0" do not generate an interrupt. In this case, the ninth bit simply separates the address from the serial data.

### 19.9.1 Sample Protocol for Master/Slave Interaction

When the master device wants to transmit a block of data to one of several slaves on a serial line, it first sends out an address byte to identify the target slave. Note that in this case, an address byte differs from a data byte: In an address byte, the 9<sup>th</sup> bit is "1" and in a data byte, it is "0".

The address byte interrupts all slaves so that each slave can examine the received byte and see if it is being addressed. The addressed slave then clears its MCE bit and prepares to receive incoming data bytes.

The MCE bits of slaves that were not addressed remain set, and they continue operating normally while ignoring the incoming data bytes.

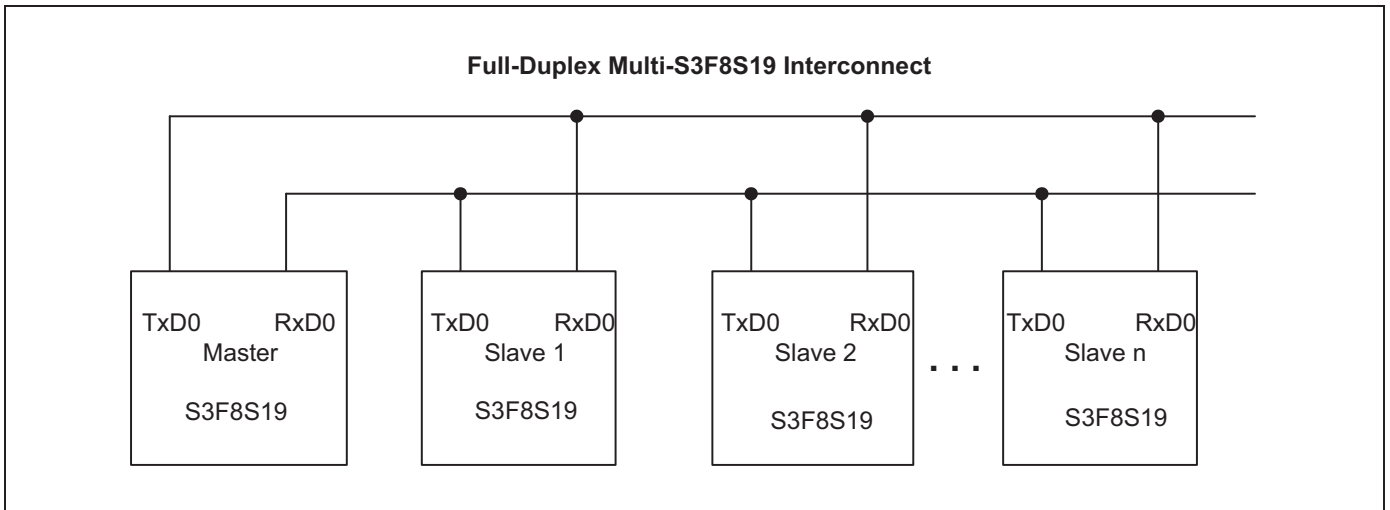
While the MCE bit setting has no effect in mode 0, you can use it in mode 1 to check the validity of the stop bit. For mode 1 reception, if MCE is "1", the receive interrupt will be issue unless a valid stop bit is received.

### 19.9.2 Setup Procedure for Multiprocessor Communications

The steps to configure multiprocessor communications are:

1. Set all S3F8S19/F8S15 devices (masters and slaves) to UART 0 mode 2 or 3.
2. Write the MCE bit of all the slave devices to "1".
3. The transmission protocol of master device is:
  - First byte: the address identifying the target slave device (ninth bit = "1")
  - Next bytes: data (ninth = "0")
4. When the target slave receives the first byte, all of the slaves are interrupted because the ninth data bit is "1". The targeted slave compares the address byte to its own address and then clears its MCE bit in order to receive incoming data. The other slaves continue operating normally.

[Figure 19-10](#) illustrates the connection example of multiprocessor serial data communications.



**Figure 19-10 Connection Example for Multiprocessor Serial Data Communications**

# 20

## UART 1

### 20.1 Overview

The UART 1 block has a full-duplex serial port with programmable operating modes:

There are one synchronous mode and three Universal Asynchronous Receiver/Transmitter (UART) modes:

- Serial I/O with baud rate of  $f_U / (16 \times (\text{BRDATA1} + 1))$
- 8-bit UART mode: variable baud rate
- 9-bit UART mode:  $f_U / 16$
- 9-bit UART mode: variable baud rate

You can access UART 1 receive and transmit buffers through the data register, UDATA1 in page 8 at address 06H. Writing to the UART data register loads the transmit buffer; reading the UART 1 data register accesses a physically separate receive buffer.

When accessing a receive data buffer (shift register), reception of the next byte can begin before CPU reads the previously received byte from the receive register. However, if the first byte has not been read by the time the next byte has been completely received, one of the bytes will be lost.

In all operating modes, transmission is started when any instruction (usually a write operation) uses the UDATA1 register as its destination address. In mode 0, serial data reception starts when they receive interrupt pending bit (UART1CONH.0) is "0" and the receive enable bit (UART1CONH.4) is "1". In mode 1, 2 and 3, reception starts whenever an incoming start bit ("0") is received and the receive enable bit (UART1CONH.4) is set to "1".

## 20.2 Programming Procedure

To program the UART 1 modules, the basic steps are:

1. Configure P4.5 and P4.4 to alternative function (RxD1 (P4.5), TxD1 (P4.4)) for UART 1 module by setting the P4CONH/L register to appropriately value.
2. Load an 8-bit value to the UART1CONH/L control register to properly configure the UART 1 I/O module.
3. For interrupt generation, set the UART 1 I/O interrupt enable bit (UART1CONH.1 or UART1CONL.1) to "1".
4. When you transmit data to the UART 1 buffer, write data to UDATA1, the shift operation starts.
5. When the shift operation (receive/transmit) completes, CPU sets UART 1 pending bit (UART1CONH.0 or UART1CONL.0) to "1" and generates an UART 1 interrupt request.

### 20.2.1 UART 1 High Byte Control Register (UART1CONH)

The control register for the UART 1 is called UART1CONH in page 8 at address 04H.

The control functions of UART1CONH are:

- Select operating mode and baud rate Supports multiprocessor communication and interrupt control  
Enables/disables serial receive control Ninth data bit location for transmit and receive operations (modes 2 and 3 only)
- UART 1 receive interrupt control

A reset clears the UART1CONH value to "00H". Therefore, if you want to use UART 1 module, you should write appropriate value to UART1CONH.

### 20.2.2 UART 1 Low Byte Control Register

The control register for the UART 1 is called UART1CONL located in page 8 at address 05H.

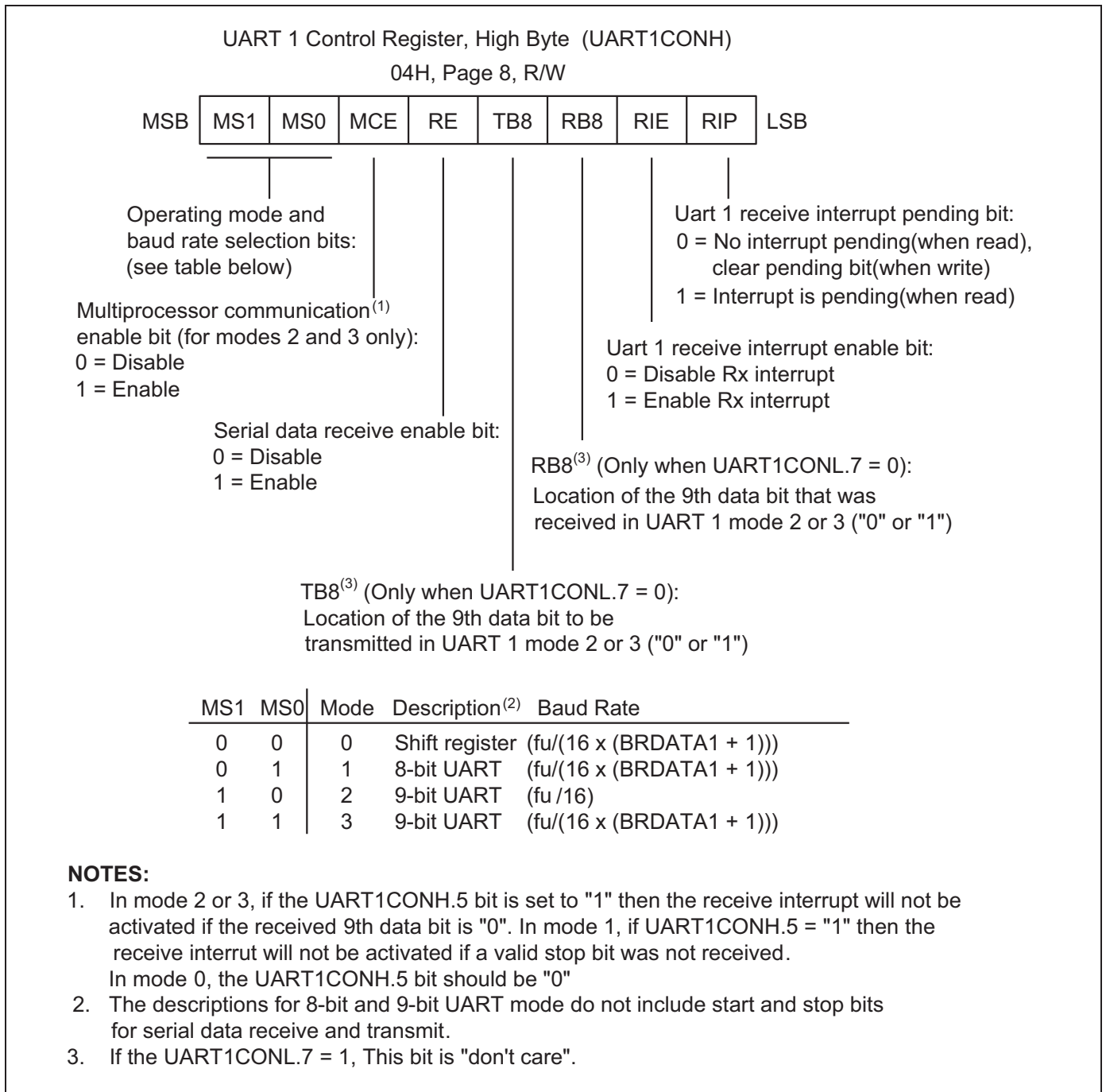
The control functions of UART1CONL are:

- Selects UART 1 transmit and receive parity-bit
- Selects UART 1 clock
- UART 1 transmit interrupt control

A reset clears the UART1CONL value to "00H". Therefore, if you want to use UART 1 module, you should write appropriate value to UART1CONL.



Figure 20-1 illustrates the UART 1 high byte control register.



**Figure 20-1 UART 1 High Byte Control Register (UART1CONH)**

Figure 20-2 illustrates the UART 1 low byte control register.

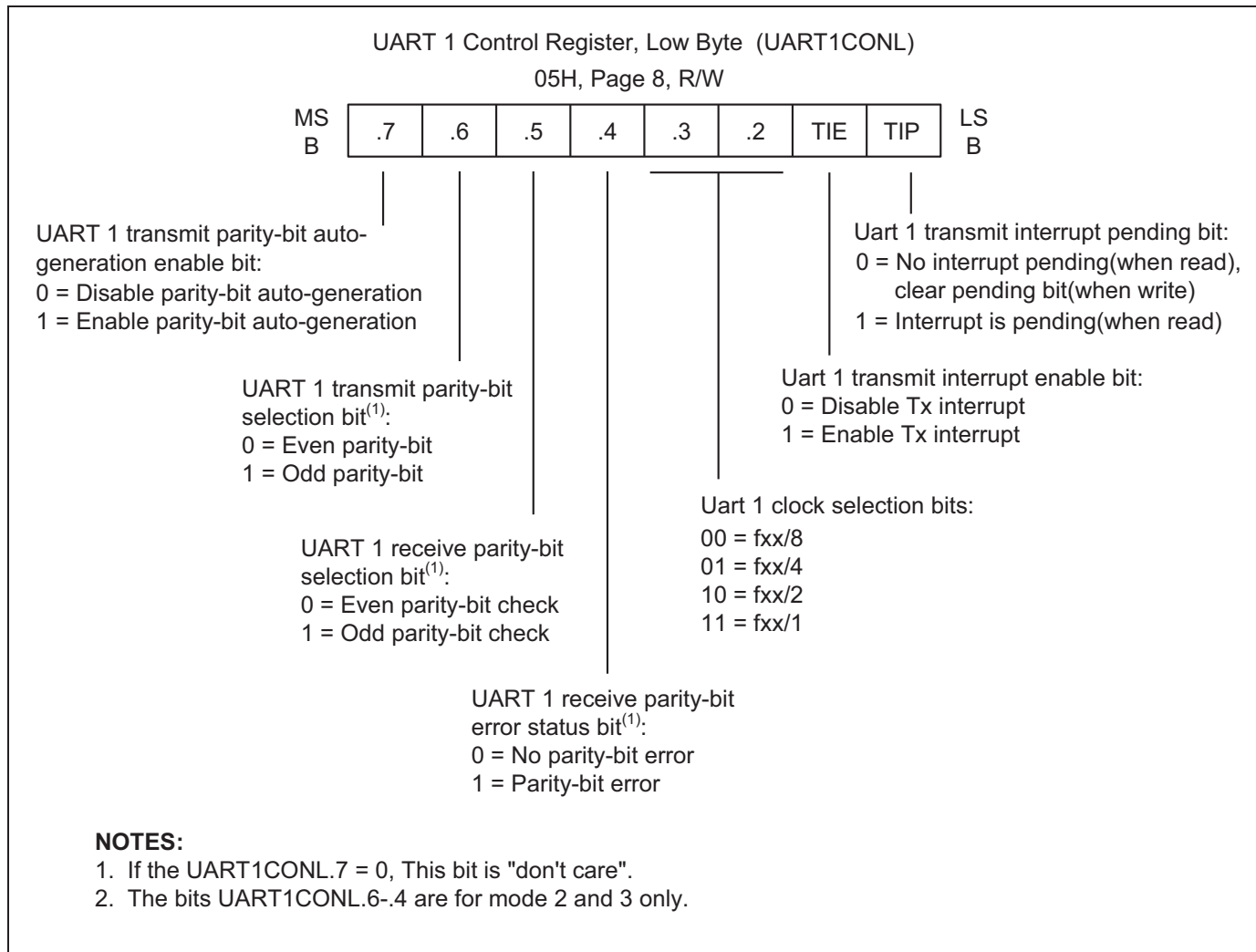


Figure 20-2 UART 1 Low Byte Control Register (UART1CONL)

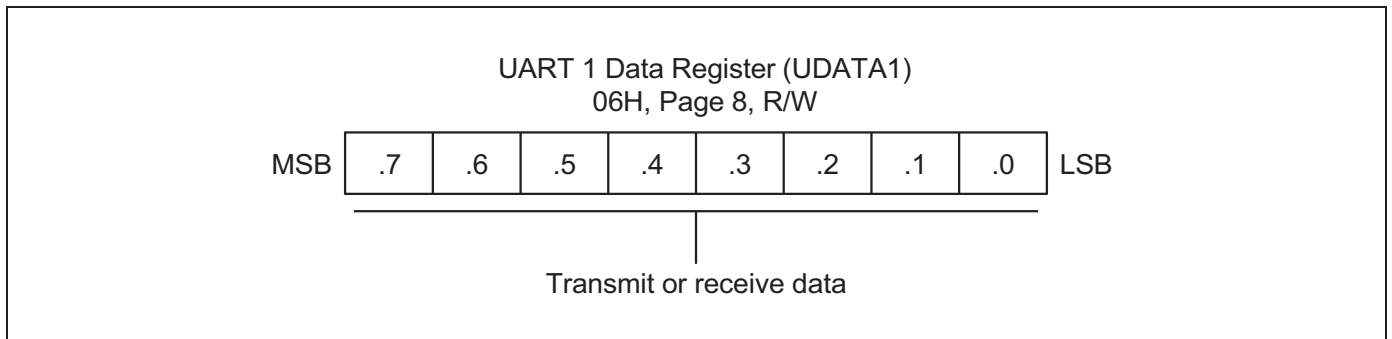
### 20.2.3 UART 1 Interrupt Pending bits

In mode 0, the receive interrupt pending bit UART1CONH.0 is set to "1" when the 8<sup>th</sup> receive data bit has been shifted. In mode 1, the UART1CONH.0 bit is set to "1" at the halfway point of the shift time of stop bit. In mode 2 or 3, the UART1CONH.0 bit is set to "1" at the halfway point of the shift time of RB8 bit. When the CPU acknowledges the receive interrupt pending condition, the UART1CONH.0 bit must then be cleared by software in the interrupt service routine.

In mode 0, the transmit interrupt pending bit UART1CONL.0 is set to "1" when the 8<sup>th</sup> transmit data bit has been shifted. In mode 1, 2 or 3, the UART1CONL.0 bit is set at the start of the stop bit. When the CPU acknowledges the transmit interrupt pending condition, the UART1CONL.0 bit must then be cleared by software in the interrupt service routine.

### 20.2.4 UART 1 Data Register

[Figure 20-3](#) illustrates the UART 1 data register.

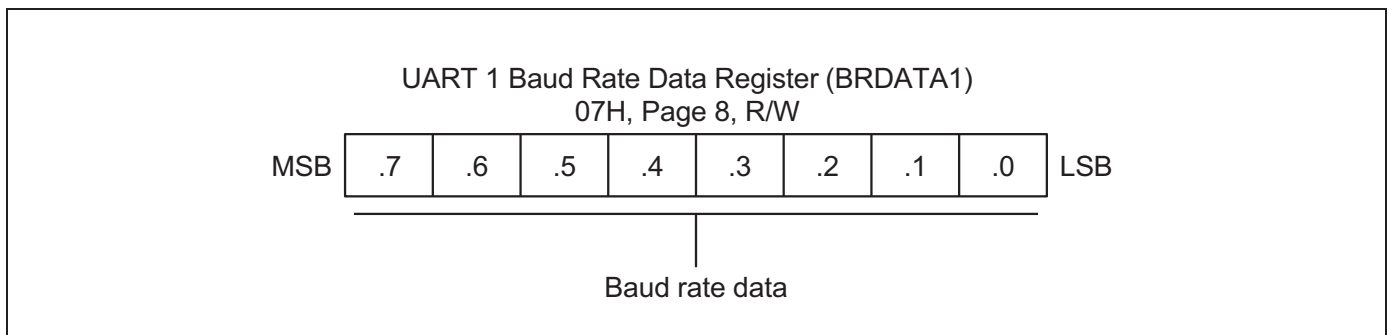


**Figure 20-3** UART 1 Data Register (UDATA1)

### 20.2.5 UART 1 Baud Rate Data Register

The value stored in the UART 1 baud rate register, BRDATA1, lets you determine the UART 1 clock rate (baud rate).

[Figure 20-4](#) illustrates the UART 1 baud rate data register.



**Figure 20-4** UART 1 Baud Rate Data Register (BRDATA1)

## 20.3 Baud Rate Calculations

This section includes:

- Mode 0 baud rate calculation
- Mode 2 baud rate calculation
- Modes 1 and 3 baud rate calculation

### 20.3.1 Mode 0 Baud Rate Calculation

In mode 0, the baud rate is determined by the UART 1 baud rate data register, BRDATA1 in set 1, bank 0 at address F5H: Mode 0 baud rate =  $f_U / (16 \times (BRDATA1 + 1))$ .

### 20.3.2 Mode 2 Baud Rate Calculation

The baud rate in mode 2 is fixed at the  $f_U$  clock frequency divided by 16: Mode 2 baud rate =  $f_U / 16$

### 20.3.3 Modes 1 and 3 Baud Rate Calculation

In modes 1 and 3, the baud rate is determined by the UART 1 baud rate data register, BRDATA1 in set 1, bank 0 at address F5H: Mode 1 and 3 baud rate =  $f_U / (16 \times (BRDATA1 + 1))$

[Table 20-1](#) lists the commonly used baud rates generated by BRDATA1.

**Table 20-1 Commonly Used Baud Rates Generated by BRDATA1**

| Mode                       | Baud Rate  | UART Clock ( $f_U$ ) | BRDATA1 |             |
|----------------------------|------------|----------------------|---------|-------------|
|                            |            |                      | Decimal | Hexadecimal |
| Mode 2                     | 0.5 MHz    | 8 MHz                | x       | x           |
| Mode 0<br>Mode 1<br>Mode 3 | 230,400 Hz | 11.0592 MHz          | 02      | 02H         |
|                            | 115,200 Hz | 11.0592 MHz          | 05      | 05H         |
|                            | 57,600 Hz  | 11.0592 MHz          | 11      | 0BH         |
|                            | 38,400 Hz  | 11.0592 MHz          | 17      | 11H         |
|                            | 19,200 Hz  | 11.0592 MHz          | 35      | 23H         |
|                            | 9,600 Hz   | 11.0592 MHz          | 71      | 47H         |
|                            | 4,800 Hz   | 11.0592 MHz          | 143     | 8FH         |
|                            | 62,500 Hz  | 10 MHz               | 09      | 09H         |
|                            | 9,615 Hz   | 10 MHz               | 64      | 40H         |
|                            | 38,461 Hz  | 8 MHz                | 12      | 0CH         |
|                            | 12,500 Hz  | 8 MHz                | 39      | 27H         |
|                            | 19,230 Hz  | 4 MHz                | 12      | 0CH         |
| 9,615 Hz                   | 4 MHz      | 25                   | 19H     |             |



## 20.5 UART 1 Mode 0 Function Description

In mode 0, UART 1 is input and output through the RxD1 (P4.5) pin and TxD1 (P4.4) pin outputs the shift clock. Data is transmitted or received in 8-bit units only. The LSB of the 8-bit value is transmitted (or received) first.

### 20.5.1 Mode 0 Transmit Procedure

The steps of Mode 0 transmit procedure are:

1. Select the UART 1 clock, UART1CONL.3 and .2.
2. Set the UART 1 transmit parity-bit auto generation enable or disable bit (UART1CONL.7).
3. Select mode 0 by setting UART1CONH.7 and .6 to "00B".
4. Write transmission data to the shift register UDATA1 (06H, page 8) to start the transmission operation.

### 20.5.2 Mode 0 Receive Procedure

The steps of Mode 0 receive procedure are:

1. Select the UART 1 clock, UART1CONL.3 and .2.
2. Set the UART 1 transmit parity-bit auto generation enable or disable bit (UART1CONL.7).
3. Select mode 0 by setting UART1CONH.7 and .6 to "00B".
4. Clear the receive interrupt pending bit (UART1CONH.0) by writing a "0" to UART1CONH.0.
5. Set the UART 1 receive enable bit (UART1CONH.4) to "1".
6. The shift clock will now be output to the TxD1 (P4.4) pin and will read the data at the RxD1 (P4.5) pin. A UART 1 receive interrupt occurs when UART1CONH.1 is set to "1".

Figure 20-6 illustrates the timing diagram for serial port Mode 0 operation.

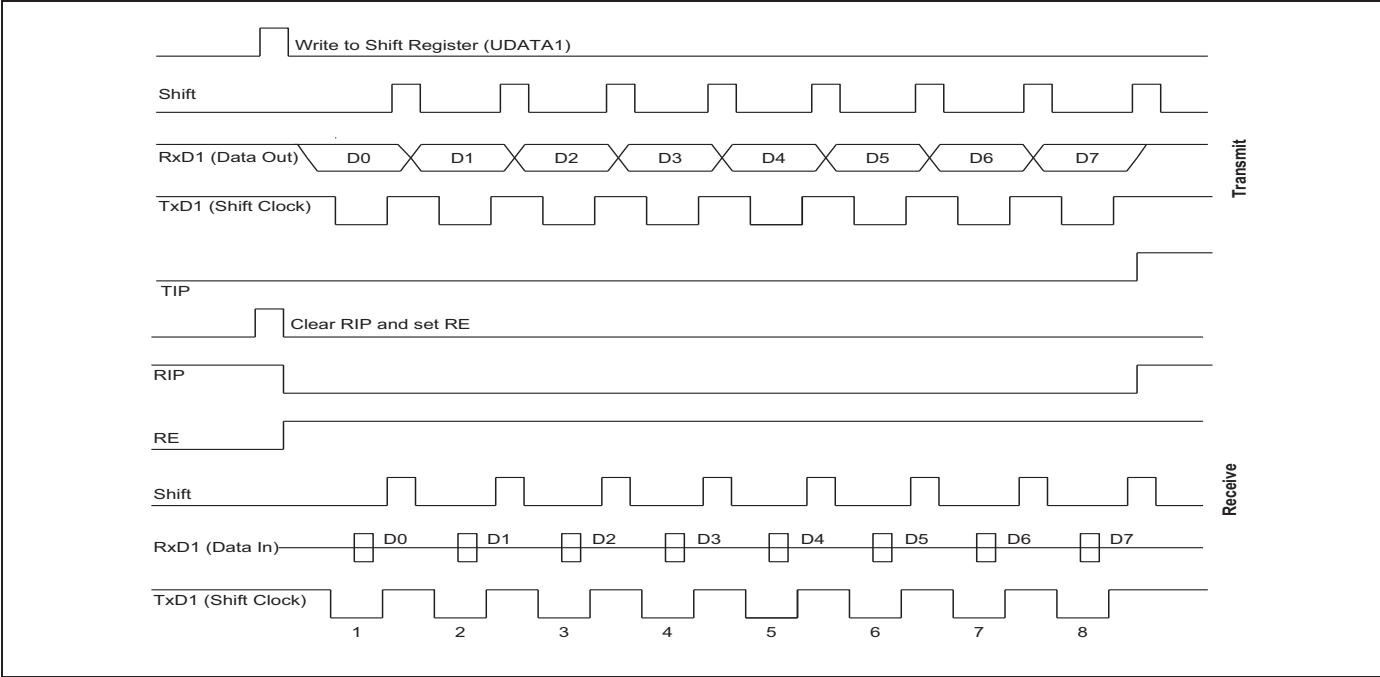


Figure 20-6 Timing Diagram for Serial Port Mode 0 Operation

## 20.6 Serial Port Mode 1 Function Description

In mode 1, 10 bits are transmitted through the TxD1 (P4.4) pin or received through the RxD1 (P4.5) pin.

The three components of each data frame are:

- Start bit ("0")
- 8 data bits (LSB first)
- Stop bit ("1")

The baud rate for mode 1 is variable.

### 20.6.1 Mode 1 Transmit Procedure

The steps of Mode 1 transmit procedure are:

1. Select the UART 1 clock, UART1CONL.3 and .2.
2. Set the UART 1 transmit parity-bit auto generation enable or disable bit (UART1CONL.7).
3. Select the baud rate that BRDATA1 generates.
4. Select mode 1 (8-bit UART) by setting UART1CONH bits 7 and 6 to "01B".
5. Write transmission data to the shift register UDATA1 (06H, page 8). The start and stop bits are generated automatically by hardware.

### 20.6.2 Mode 1 Receive Procedure

The steps of Mode 1 receive procedure are:

1. Select the UART 1 clock, UART1CONL.3 and .2.
2. Set the UART 1 transmit parity-bit auto generation enable or disable bit (UART1CONL.7).
3. Select the baud rate that BRDATA1 generates.
4. Select mode 1 and set the RE (Receive Enable) bit in the UART1CONH register to "1".
5. The start bit low ("0") condition at the RxD1 (P4.5) pin will cause the UART 1 module to start the serial data receive operation.



Figure 20-7 illustrates the timing diagram for serial port Mode 1 operation.

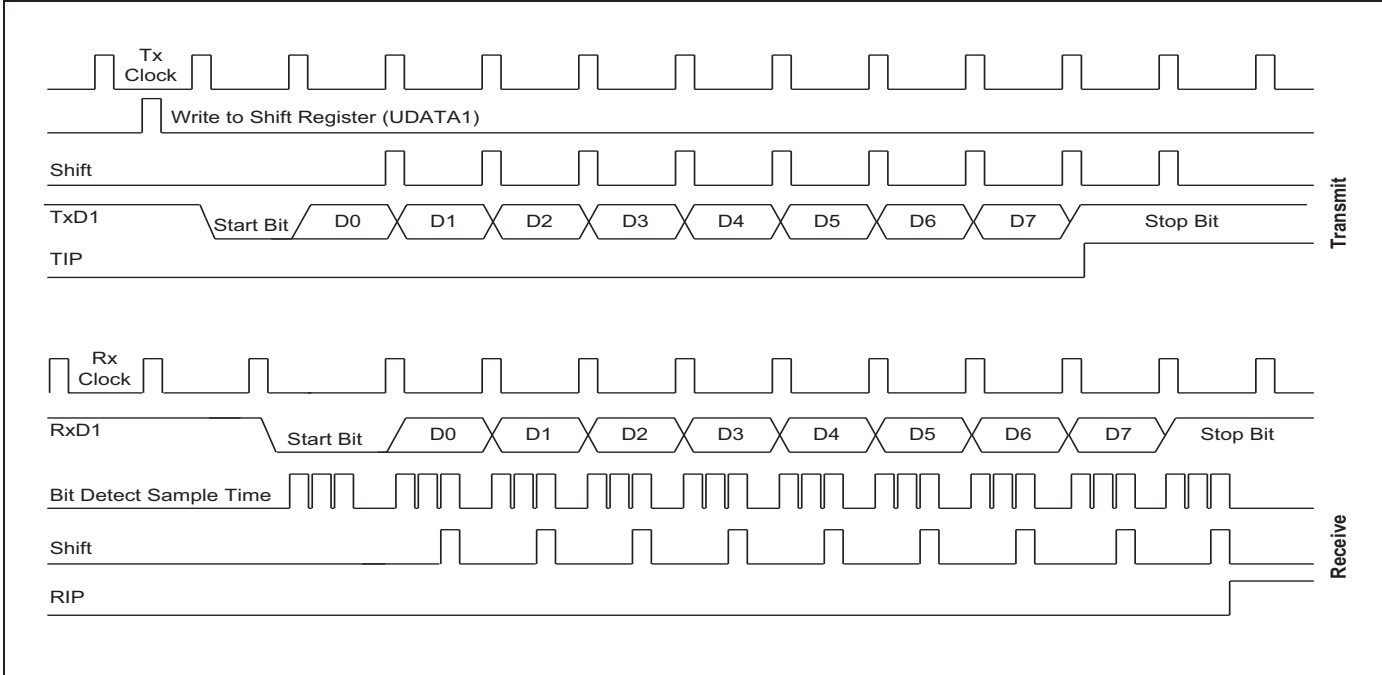


Figure 20-7 Timing Diagram for Serial Port Mode 1 Operation

## 20.7 Serial Port Mode 2 Function Description

In mode 2, 11 bits are transmitted through the TxD1 (P4.4) pin or received through the RxD1 (P4.5) pin.

The four components of each frame are:

- Start bit ("0")
- 8 data bits (LSB first)
- Programmable 9<sup>th</sup> data bit
- Stop bit ("1")

The 9<sup>th</sup> data bit to be transmitted can be assigned a value of "0" or "1" by writing the TB8 bit (UART1CONH.3). When receiving, the 9<sup>th</sup> data bit that it receives is written to the RB8 bit (UART1CONH.2), while the stop bit is ignored. The baud rate for mode 2 is  $f_U/16$  clock frequency.

### 20.7.1 Mode 2 Transmit Procedure

The steps for Mode 2 transmit procedure are:

1. Select the UART 1 clock, UART1CONL.3 and .2.
2. Set the UART 1 transmit parity-bit auto generation enable or disable bit (UART1CONL.7).
3. Select mode 2 (9-bit UART) by setting UART1CONH bits 7 and 6 to "10B". Also, select the 9<sup>th</sup> data bit to be transmitted by writing TB8 to "0" or "1".
4. Write transmission data to the shift register, UDATA1 (06H, page 8), to start the transmit operation.

### 20.7.2 Mode 2 Receive Procedure

The steps for Mode 2 receive procedure are:

1. Select the UART 1 clock, UART1CONL.3 and .2.
2. Set the UART 1 transmit parity-bit auto generation enable or disable bit (UART1CONL.7).
3. Select mode 2 and set the receive enable bit (RE) in the UART1CONH register to "1".
4. The receive operation starts when the signal at the RxD1 (P4.5) pin goes to low level.

Figure 20-8 illustrates the timing diagram for serial port Mode 2 operation.

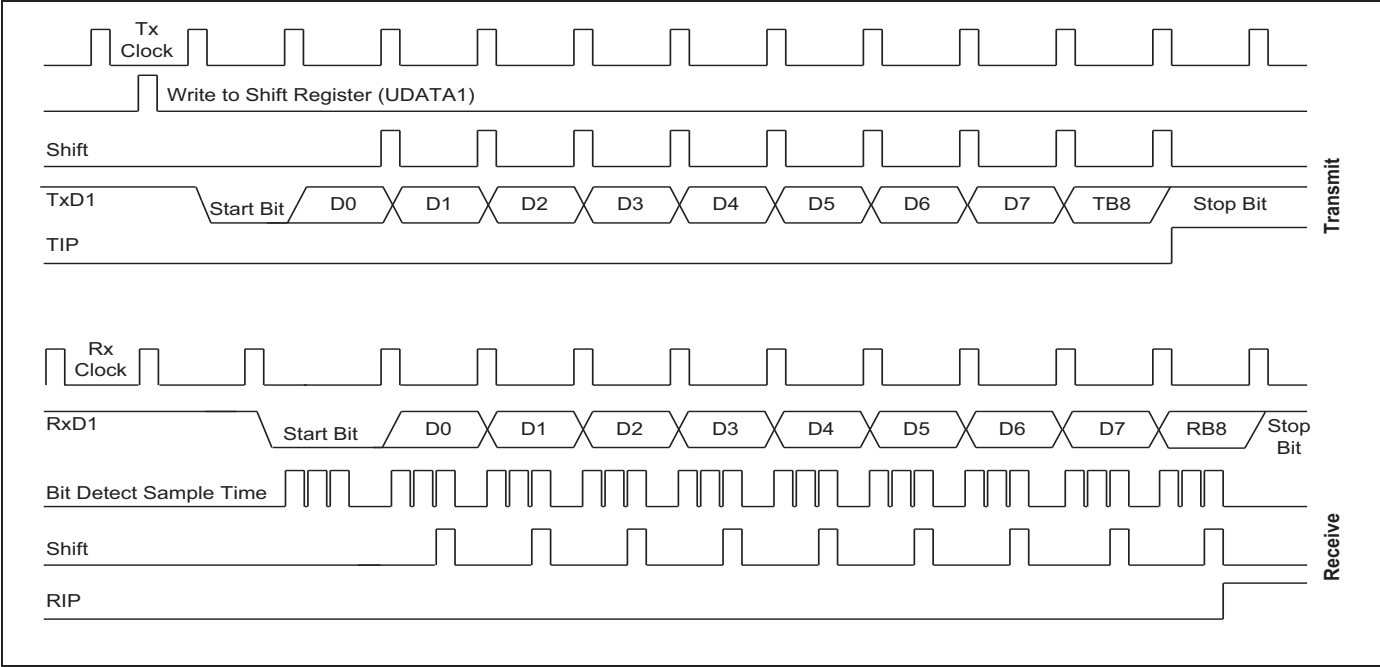


Figure 20-8 Timing Diagram for Serial Port Mode 2 Operation

## 20.8 Serial Port Mode 3 Function Description

In mode 3, 11 bits are transmitted through the TxD1 (P4.4) pin or received through the RxD1 (P4.5) pin. Mode 3 is identical to mode 2 except for baud rate, which is variable.

The four components of each data frame are:

- Start bit ("0")
- 8 data bits (LSB first)
- Programmable 9<sup>th</sup> data bit
- Stop bit ("1")

### 20.8.1 Mode 3 Transmit Procedure

The steps for Mode 3 transmit procedure are:

1. Select the UART 1 clock, UART1CONL.3 and .2.
2. Set the UART 1 transmit parity-bit auto generation enable or disable bit (UART1CONL.7).
3. Select mode 3 operation (9-bit UART) by setting UART1CONH bits 7 and 6 to "11B". Also, select the 9<sup>th</sup> data bit to be transmitted by writing UART1CONH.3 (TB8) to "0" or "1".
4. Write transmission data to the shift register, UDATA1 (06H, page 8), to start the transmit operation.

### 20.8.2 Mode 3 Receive Procedure

The steps for Mode 3 receive procedure are:

1. Select the UART 1 clock, UART1CONL.3 and .2.
2. Set the UART 1 transmit parity-bit auto generation enable or disable bit (UART1CONL.7).
3. Select mode 3 and set the RE (Receive Enable) bit in the UART1CONH register to "1".
4. The receive operation will be started when the signal at the RxD1 (P4.5) pin goes to low level.

Figure 20-9 illustrates the timing diagram for serial port Mode 3 operation.

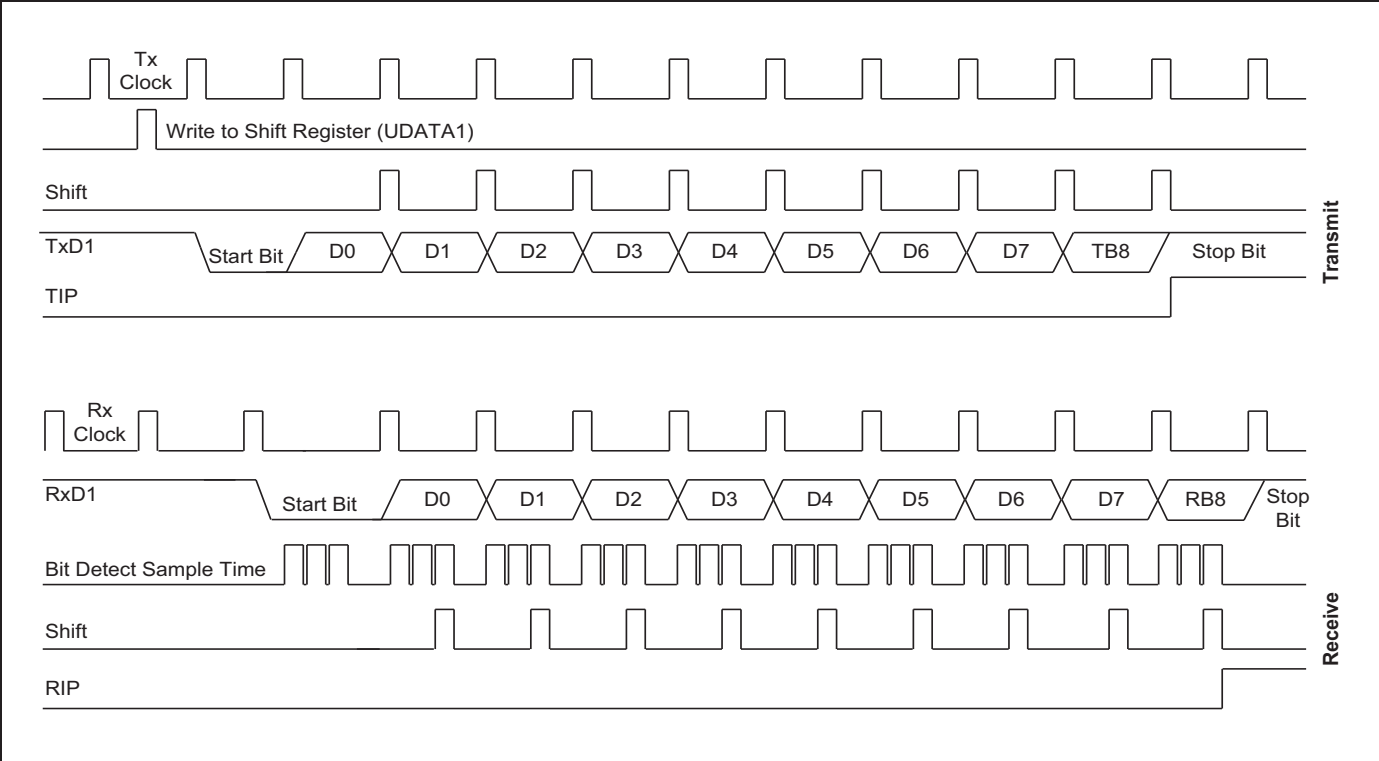


Figure 20-9 Timing Diagram for Serial Port Mode 3 Operation

## 20.9 Serial Communication for Multiprocessor Configurations

The S3F8-series multiprocessor communication feature enables a "master" S3F8S19/F8S15 to send a multiple-frame serial message to a "slave" device in a multi- S3F8S19/F8S15 configuration. It does this without interrupting other slave devices that may be on the same serial line.

This feature can be used only in UART modes 2 or 3. In these modes 2 and 3, 9 data bits are received. The 9<sup>th</sup> bit value is written to RB8 (UART1CONH.2). The data receive operation is concluded with a stop bit. You can program this function so that when the stop bit is received, the serial interrupt will be generated only if RB8 = "1".

To enable this feature, you should set the MCE bit in the UART1CONH register. When the MCE bit is "1", serial data frames that are received with the ninth bit = "0" do not generate an interrupt. In this case, the ninth bit simply separates the address from the serial data.

### 20.9.1 Sample Protocol for Master/Slave Interaction

When the master device wants to transmit a block of data to one of several slaves on a serial line, it first sends out an address byte to identify the target slave. Note that in this case, an address byte differs from a data byte: In an address byte, the 9<sup>th</sup> bit is "1" and in a data byte, it is "0".

The address byte interrupts all slaves so that each slave can examine the received byte and see if it is being addressed. The addressed slave then clears its MCE bit and prepares to receive incoming data bytes.

The MCE bits of slaves that were not addressed remain set, and they continue operating normally while ignoring the incoming data bytes.

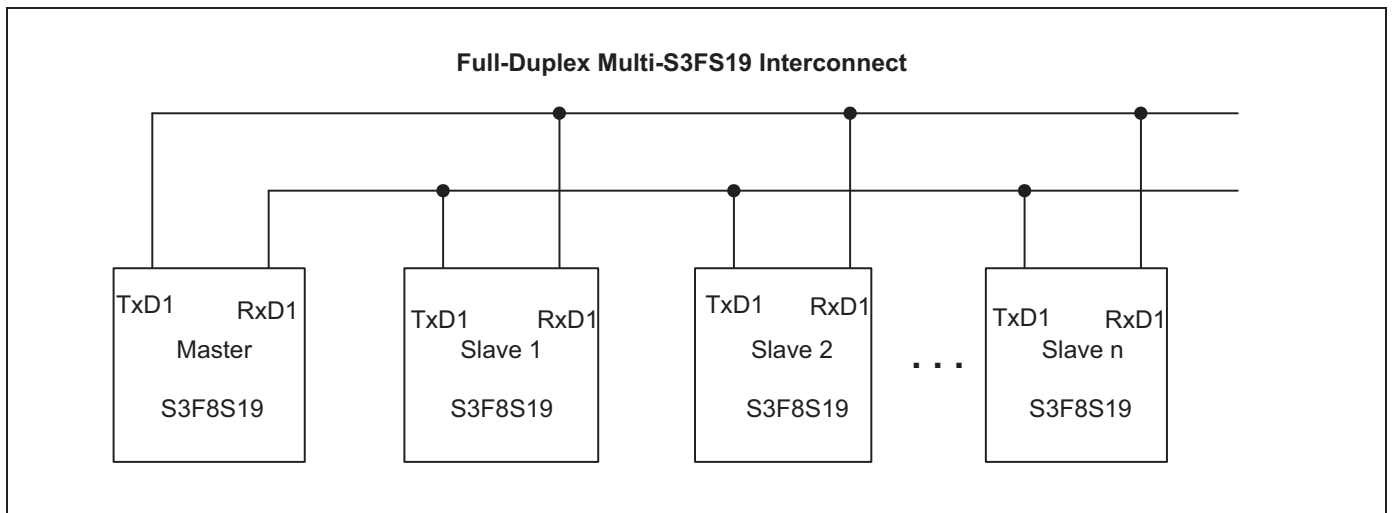
While the MCE bit setting has no effect in mode 0, you can use it in mode 1 to check the validity of the stop bit. For mode 1 reception, if MCE is "1", the receive interrupt will be issue unless a valid stop bit is received.

### 20.9.2 Setup Procedure for Multiprocessor Communications

The steps to configure multiprocessor communications are:

1. Set all S3F8S19/F8S15 devices (masters and slaves) to UART 1 mode 2 or 3.
2. Write the MCE bit of all the slave devices to "1".
3. The transmission protocol of master device is:
  - First byte: the address identifying the target slave device (ninth bit = "1")
  - Next bytes: data (ninth = "0")
4. When the target slave receives the first byte, all of the slaves are interrupted because the ninth data bit is "1". The targeted slave compares the address byte to its own address and then clears its MCE bit in order to receive incoming data. The other slaves continue operating normally.

[Figure 20-10](#) illustrates the connection example of multiprocessor serial data communications



**Figure 20-10 Connection Example for Multiprocessor Serial Data Communications**

# 21 Embedded Flash Memory Interface

## 21.1 Overview

S3F8S19/F8S15 has an on-chip flash memory internally instead of masked ROM. The flash memory is accessed by "LDC" instruction. This is a sector erasable and byte programmable flash. You can program the data in a flash memory area any time.

The two operating features of 32/16 K byte memory of S3F8S19/F8S15 are:

- Tool Program Mode (Refer to Chapter 25 "More Information")
- User Program Mode



## 21.2 User Program Mode

This mode supports:

- Sector erase
- Byte programming
- Byte read
- Protection mode (Hard lock protection)

The read protection mode is available only in Tool Program mode. Therefore, to make a chip into read protection, you must select a read protection option when you program by using a programming tool.

S3F8S19/F8S15 has the pumping circuit internally. Therefore, 12.5 V into Vpp (Test) pin is not needed. To program a flash memory in this mode several control registers will be used.

There are four kinds of functions:

- Programming
- Reading
- Sector erase
- Hard lock protection

### NOTE:

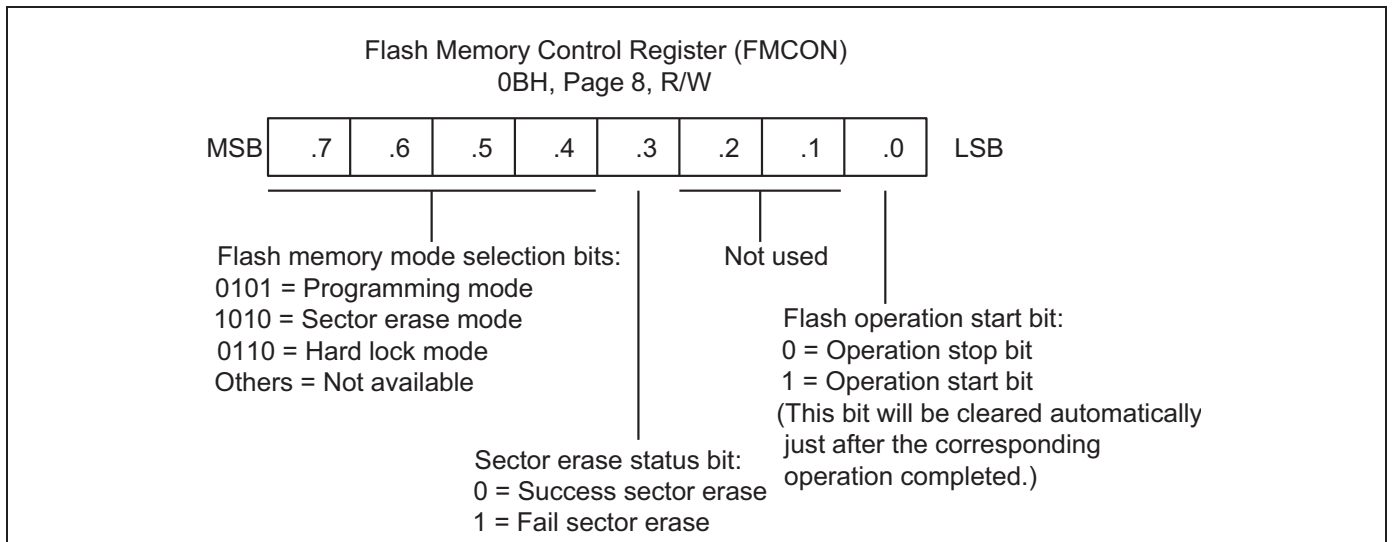
1. The user program mode cannot be used when the CPU operates with the sub-system clock.
2. Ensure to execute the DI instruction before starting user program mode. The user program mode verifies the interrupt request register (IRQ). When an interrupt request is generated, user program mode stops.
3. User program mode also stops by an interrupt request that it masks even in the DI status. To prevent this, disable the interrupt by using the each peripheral interrupt enable bit.

### 21.2.1 Flash Memory Control Register

Flash memory control register (FMCON) register is available only in user program mode to:

- Select the Flash Memory operation mode
- Select sector erase
- Select byte programming
- Make the flash memory into a hard lock protection

[Figure 21-1](#) illustrates the flash memory control register.



**Figure 21-1 Flash Memory Control Register (FMCON)**

The bit 0 of FMCON register (FMCON.0) is a start bit for Erase and Hard Lock operation mode. Therefore, operation of Erase and Hard Lock mode is activated when you set FMCON.0 to "1". Erase (Sector erase) or hard lock instruction need execution time. Therefore, you should insert wait time before a byte programming or a byte read of same sector area by using "LDC" instruction. When you read or program a byte data from or into flash memory, this bit is not needed to manipulate.

The sector erase status bit is read-only. If an interrupt is requested during the operation of "Sector erase", the operation of "Sector erase" is discontinued, and the interrupt is served by CPU. Therefore, you should verify the status bit after executing "Sector erase". The "sector erase" operation is successful when the bit is logic "0", and is failure if the bit is logic "1".

### 21.2.2 Flash Memory User Programming Enable Register

The FMUSR register is used for a safety operation of the flash memory. This register protects undesired erase or program operation from malfunctioning of CPU that is due to electrical noise.

After reset, the user-programming mode is disabled, because the value of FMUSR is "00000000B" by reset operation. To operate the flash memory, you can use the user programming mode by setting the value of FMUSR to "10100101B". If FMUSR is set to value other than "10100101b", User Program mode is disabled.

[Figure 21-2](#) illustrates the flash memory user programming enable register.

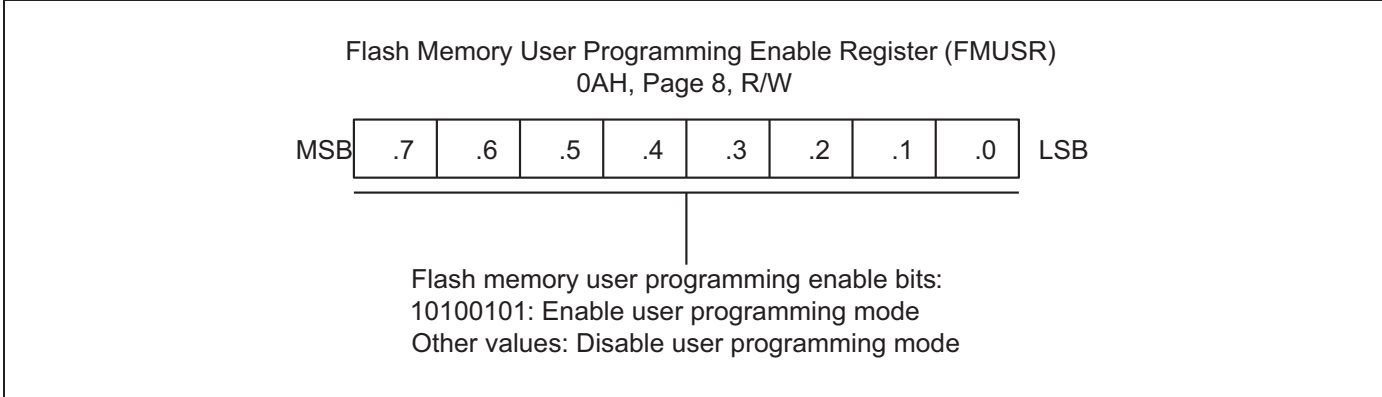


Figure 21-2 Flash Memory User Programming Enable Register (FMUSR)

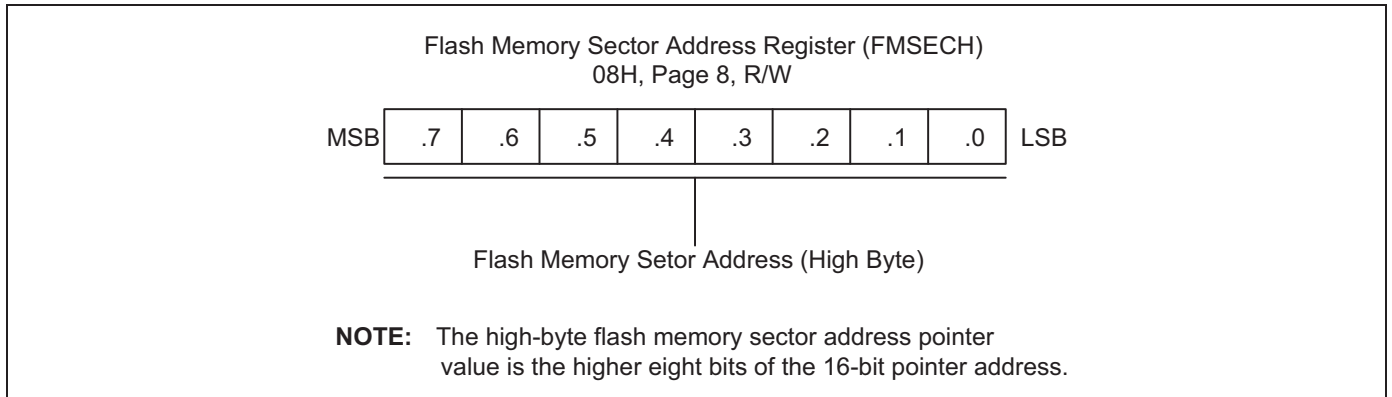
### 21.2.3 Flash Memory Sector Address Registers

There are two sector address registers for addressing a sector to be erased. The Flash Memory Sector Address Register Low Byte (FMSECL) indicates the low byte of sector address. The Flash Memory Sector Address Register High Byte (FMSECH) indicates the high byte of sector address. The FMSECH is needed for S3F8S19/F8S15 because it has 128 sectors, respectively. One sector consists of 128 bytes. Each address of sector starts with XX00H or XX80H, that is, a base address of sector is XX00H or XX80H. Therefore, FMSECL register 6-0 does not indicate whether the value is "1" or "0".

It is recommend to load sector base address into FMSECH and FMSECL register. When programming the flash memory, you should write data after loading sector base address located in the target address to write data into FMSECH and FMSECL register.

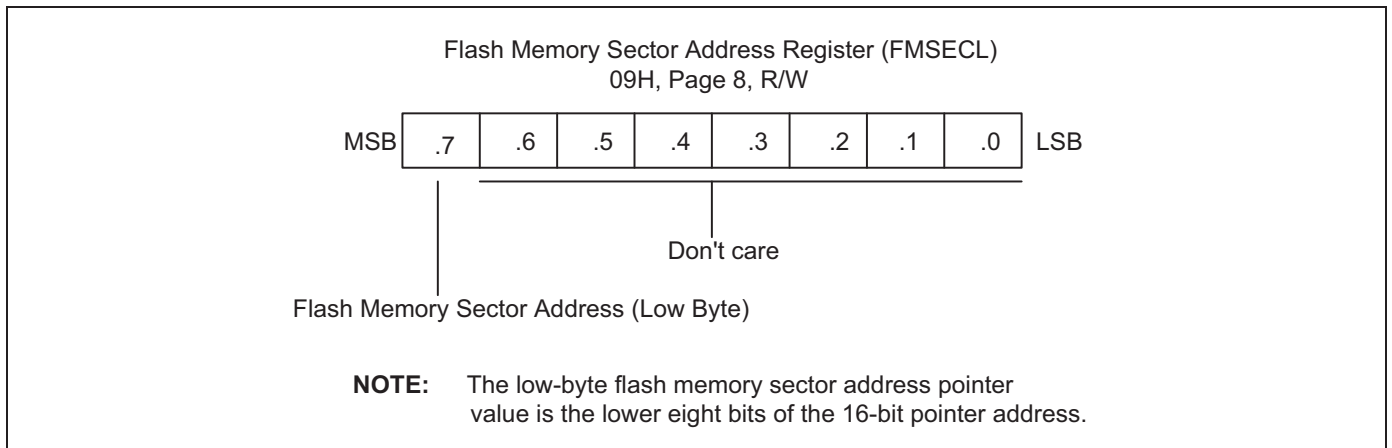
If the next operation is also to write data, you should verify whether next address is located in the same sector or not. In case of other sectors, you should load sector address to FMSECH and FMSECL register according to the sector.

[Figure 21-3](#) illustrates the flash memory sector address register high byte.



**Figure 21-3 Flash Memory Sector Address Register High Byte (FMSECH)**

[Figure 21-4](#) illustrates the flash memory sector address register low byte.



**Figure 21-4 Flash Memory Sector Address Register Low Byte (FMSECL)**

### 21.3 ISP (On-Board Programming) Sector

ISP™ sectors located in program memory area can store On Board Program software (Boot program code for upgrading application code by interfacing with I/O port pin). The ISP sectors cannot be erased or programmed by LDC instruction for the safety of On Board Program software.

The ISP sectors are available only when the ISP enable/disable bit is set 0, that is, enable ISP at the Smart Option. If you do not want to use ISP sector, you can use this area as a normal program memory (can erase or program by LDC instruction) by setting ISP disable bit ("1") at the Smart Option. Even if ISP sector is selected, ISP sector can be erased or programmed in the Tool Program mode by using Serial programming tools.

The size of ISP sector can vary by settings of Smart Option. You can select appropriate ISP sector size according to the size of On Board Program software.

[Figure 21-5](#) illustrates the program memory address space.

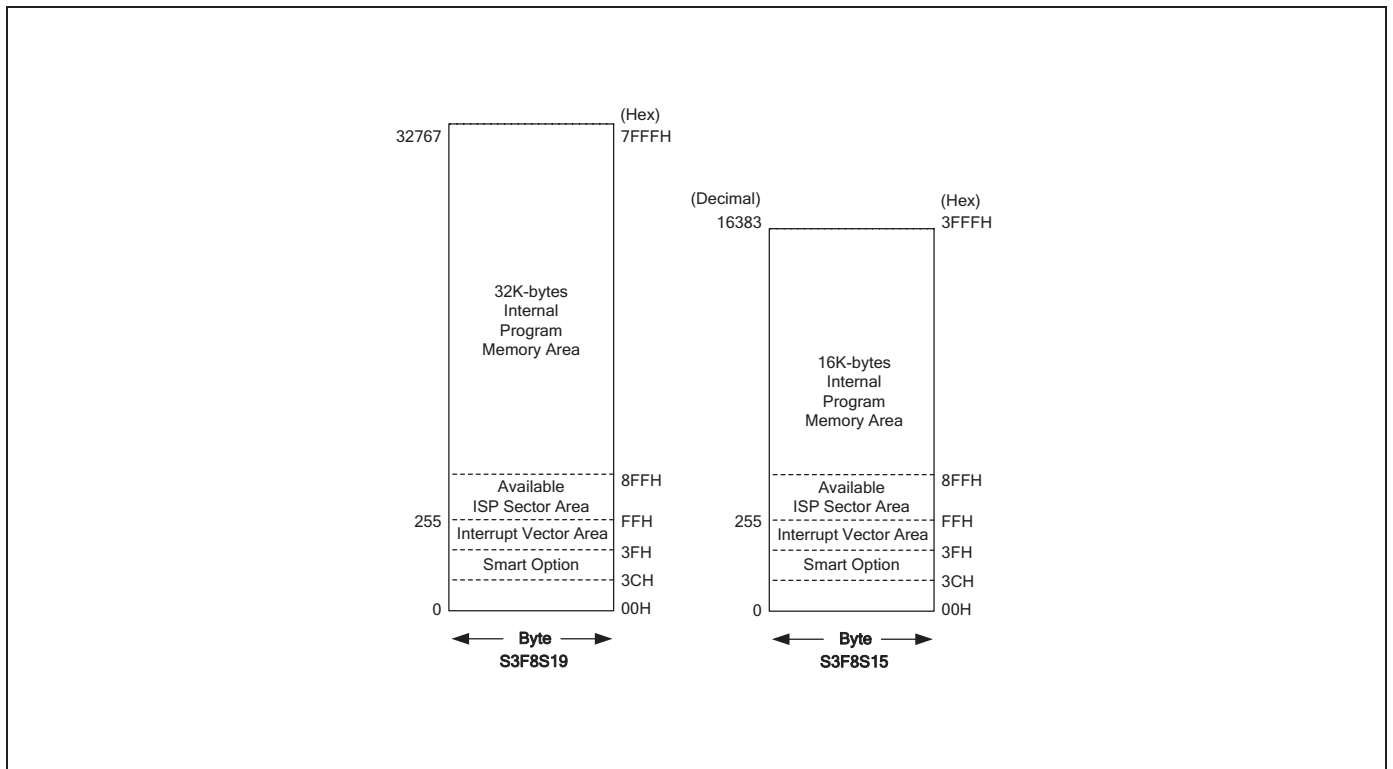


Figure 21-5 Program Memory Address Space

[Table 21-1](#) lists the ISP sector size.

**Table 21-1 ISP Sector Size**

| Smart Option(003EH) ISP Size Selection Bit |       |       | Area of ISP Sector    | ISP Sector Size |
|--|-------|-------|-----------------------|-----------------|
| Bit 2                                      | Bit 1 | Bit 0 |                       |                 |
| 1  | x     | x     | 0                     | 0               |
| 0  | 0     | 0     | 100H–1FFH (256 Byte)  | 256 Bytes       |
| 0  | 0     | 1     | 100H–2FFH (512 Byte)  | 512 Bytes       |
| 0  | 1     | 0     | 100H–4FFH (1024 Byte) | 1024 Bytes      |
| 0  | 1     | 1     | 100H–8FFH (2048 Byte) | 2048 Bytes      |

**NOTE:** The area of the ISP sector selected by Smart Option bit (003EH.2–003EH.0) cannot be erased and programmed by LDC instruction in User Program mode.

## 21.4 ISP Reset Vector and ISP Sector Size

At the Smart Option, when you use ISP sectors by setting the ISP Enable/Disable bit to "0" and the Reset Vector Selection bit to "0", you can select the reset vector address of CPU as listed in [Table 21-2](#). You can do this by setting the ISP Reset Vector Address Selection bits.

[Table 21-2](#) lists the reset vector address.

**Table 21-2 Reset Vector Address**

| Smart Option (003EH)<br>ISP Reset Vector Address Selection Bit |       |       | Reset Vector<br>Address After POR | Usable Area for<br>ISP Sector | ISP Sector Size |
|--|-------|-------|-----------------------------------|-------------------------------|-----------------|
| Bit 7  | Bit 6 | Bit 5 |                                   |                               |                 |
| 1  | x     | x     | 0100H                             | –                             | –               |
| 0  | 0     | 0     | 0200H                             | 100H–1FFH                     | 256 Bytes       |
| 0  | 0     | 1     | 0300H                             | 100H–2FFH                     | 512 Bytes       |
| 0  | 1     | 0     | 0500H                             | 100H–4FFH                     | 1024 Bytes      |
| 0  | 1     | 1     | 0900H                             | 100H–8FFH                     | 2048 Bytes      |

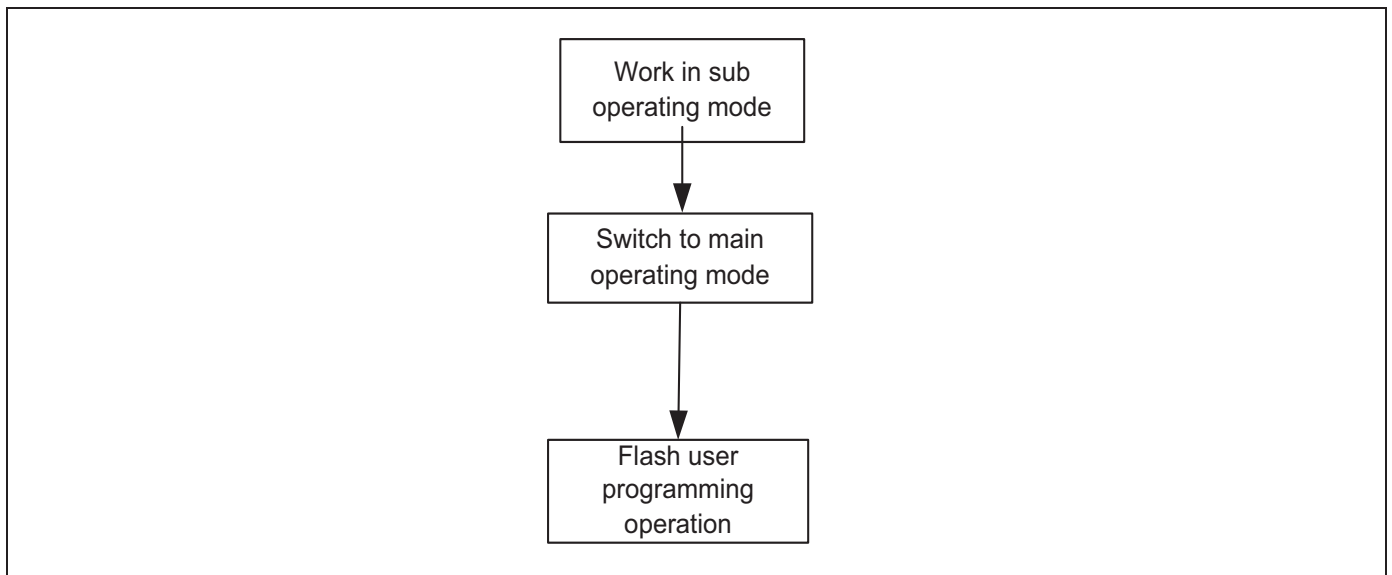
**NOTE:** The selection of the ISP reset vector address by Smart Option (003EH.7–003EH.5) does not depend on the selection of ISP sector size by Smart Option (003EH.2–003EH.0).

## 21.5 Sector Erase

You can erase a flash memory partially by using sector erase function only in User Program Mode. The only unit of flash memory that you can erase or program in User Program Mode is called sector.

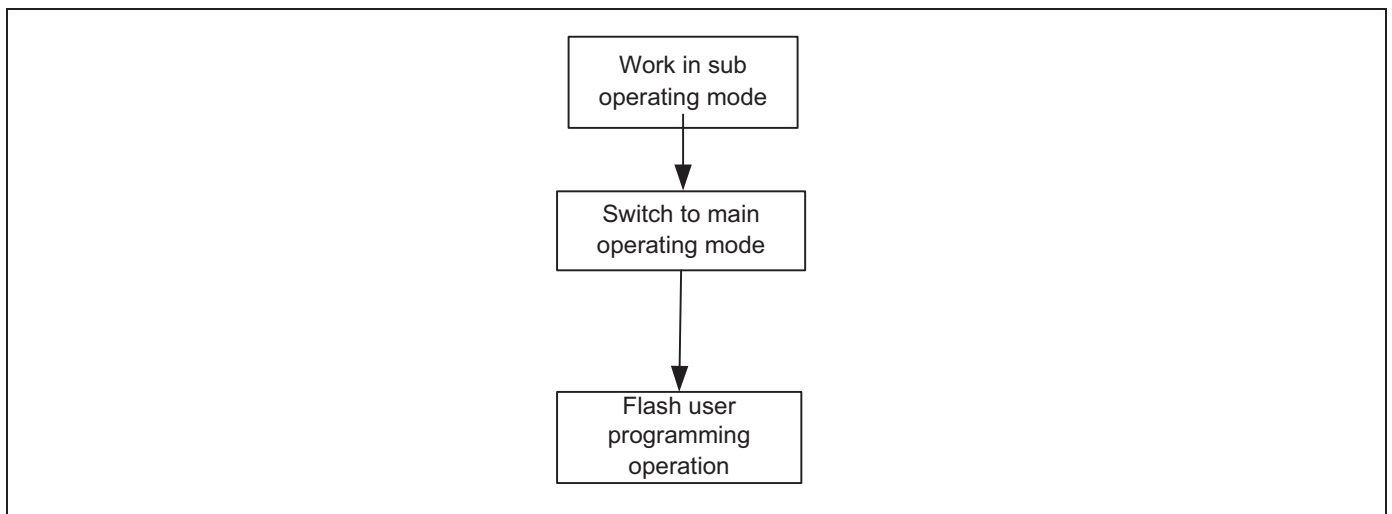
The program memory of S3F8S19/F8S15 is divided into 128 sectors for unit of erase and programming, respectively. Every sector has all 128 byte sizes of program memory areas. Therefore, you should erase each sector first to program a new data (byte) into a sector. It requires minimum 10ms delay time for erase after setting sector address and triggering erase start bit (FMCON.0). Tool Program Modes (MDS mode tool or Programming tool) does not supports sector erase.

[Figure 21-6](#) illustrates the sector configurations in user program mode.



**Figure 21-6 Sector Configurations in User Program Mode**

[Figure 21-7](#) illustrates the flash operation sequence in sub operating mode.



**Figure 21-7 Flash Operation Sequence in Sub Operating Mode**

### The Sector program procedure in User program Mode

1. Set Flash Memory User Programming Enable Register (FMUSR) to "10100101B".
2. Set Flash Memory Sector Address Register (FMSECH/ FMSECL).
3. Set Flash Memory Control Register (FMCON) to "10100001B".
4. Set Flash Memory User Programming Enable Register (FMUSR) to "00000000B".
5. Verify the "Sector erase status bit" whether "Sector erase" is successful or not.

[Example 21-1](#) shows the sector erase.

#### Example 21-1 Sector Erase

```

•
•
reErase:  AND    OSCCON, #0F6H           ; If work in sub operating mode, need to switch to main
                                                operating mode
        LD     PP, #88H
        LD     FMUSR, #0A5H          ; User Program mode enable
        LD     FMSECH, #10H
        LD     FMSECL, #00H          ; Set sector address (1000H-107FH)
        LD     FMCON, #10100001B    ; Start sector erase
        NOP                                ; Dummy Instruction, This instruction must be needed
        NOP                                ; Dummy Instruction, This instruction must be needed
        LD     FMUSR, #0              ; User Program mode disable
        TM     FMCON, #00001000B     ; Check "Sector erase status bit"
        JR     NZ, reErase            ; Jump to reErase if fail
        LD     PP, #00H

```



## 21.6 Programming

A flash memory is programmed in 1 byte unit after sector erase. And programming for safety sake, you should set FMSECH and FMSECL to flash memory sector value.

The write operation of programming starts by "LDC" instruction. You can write until 128 byte because the limit of flash sector is 128 byte. Therefore when you write 128 byte, you should reset FMSECH and FMSECL.

### The Program procedure in User program Mode

1. Ensure to erase sector before programming.
2. Set Flash Memory User Programming Enable Register (FMUSR) to "10100101B".
3. Set Flash Memory Control Register (FMCON) to "01010001B".
4. Set Flash Memory Sector Register (FMSECH, FMSECL) to sector value of write address.
5. Load a transmission data into a working register.
6. Load a flash memory upper address into upper register of pair working register.
7. Load a flash memory lower address into lower register of pair working register.
8. Load transmission data to flash memory location area on "LDC" instruction by indirectly addressing mode.
9. Set Flash Memory User Programming Enable Register (FMUSR) to "00000000B".

[Example 21-2](#) shows the program procedure.

#### Example 21-2 Program

```

•
•
AND    OSCCON, #0F6H           ; If work in sub operating mode, need to switch to main
                                   operating mode

LD     PP, #88H
LD     FMSECH, #17H
LD     FMSECL, #80H           ; Set sector address (1780H-17FFH)
LD     r2, #17H               ; Set a ROM address in the same sector 1780H-17FFH
LD     r3, #84H
LD     r4, #78H               ; Temporary data
LD     FMUSR, #0A5H           ; User Program mode enable
LD     FMCON, #01010001B      ; Start program
LDC    @rr2, r4               ; Write the data to an address of same sector (1784H)
NOP                                ; Dummy Instruction, This instruction must be needed
LD     FMUSR, #0               ; User Program mode disable
LD     PP, #00H

```

## 21.7 Reading

The read operation of programming starts by 'LDC' instruction.

### The Program procedure in User program Mode

1. Load a flash memory upper address into upper register of pair working register.
2. Load a flash memory lower address into lower register of pair working register.
3. Load receives data from flash memory location area on 'LDC' instruction by indirectly addressing mode.

[Example 21-3](#) shows the read operation.

### Example 21-3 Reading

```

•
•
AND    OSCCON, #0F6H      ; If work in sub operating mode, need to switch to main
                          ; operating mode
LD     PP, #88H
LD     R2, #3H            ; load flash memory upper address to upper of pair
                          ; working register
LD     R3, #0             ; load flash memory lower address to lower pair working
                          ; register
LOOP:  LDC    R0, @RR2     ; read data from flash memory location
                          ; (Between 300H and 3FFH)
INC    R3
CP     R3, #0H
JP     NZ, LOOP
LD     PP, #00H
•
•
•

```

## 21.8 Hard Lock Protection

You can set Hard Lock Protection by writing "0110" in FMCON7-4. If this function is enabled, then you cannot write or erase the data in a flash memory area. This protection can be released by the chip erase execution (in the tool program mode or user program mode). In terms of user program mode, the procedure of setting Hard Lock Protection is following chip erase execution. Whereas in tool mode, the manufacturer of the serial tool writer supports hardware Protection. Refer to the manual of serial program writer tool that the manufacturer provides for more information.

### The Program procedure in User program Mode

1. Set Flash Memory User Programming Enable Register (FMUSR) to "10100101B".
2. Set Flash Memory Control Register (FMCON) to "01100001B".
3. Set Flash Memory User Programming Enable Register (FMUSR) to "00000000B".

[Example 21-4](#) shows the hard lock protection.

#### Example 21-4 Hard Lock Protection

```
•
•
AND    OSCCON, #0F6H      ; If work in sub operating mode, need to switch to main
                                operating mode
LD     PP, #88H
LD     FMUSR, #0A5H      ; User Program mode enable
LD     FMCON, #01100001B ; Hard Lock mode set & start
NOP                                ; Dummy Instruction, This instruction must be needed
LD     FMUSR, #0         ; User Program mode disable
LD     PP, #00H
•
•
```

# 22 Low Voltage Detect and Low Voltage Reset

## 22.1 Low Voltage Reset

You can select internal RESET (LVR) or external RESET by using smart option (3FH.7 in ROM).

You can reset S3F8S39/38/35/34 in four ways:

- By external power-on-reset
- By the external reset input pin pulled low
- By the digital watchdog timing out
- By the Low Voltage reset circuit (LVR)

During an external power-on reset, the voltage  $V_{DD}$  is High level and the RESETB pin is forced Low level. The RESETB signal is input through a Schmitt trigger circuit where it is synchronized with the CPU clock. This brings the S3F8S19/F8S15 into a known operating status. To ensure correct start-up, you should ensure that reset signal is not released before the  $V_{DD}$  level is sufficient to allow MCU operation at the chosen frequency.

You should hold nRESET pin to low level for a minimum time interval after the power supply comes within tolerance to allow time for internal CPU clock oscillation to stabilize.

When a reset occurs during normal operation (with both  $V_{DD}$  and RESETB at High level), it forces the signal at the nRESET pin to Low and the reset operation starts. All system and peripheral control registers are then set to their default hardware reset values (see Table 8-1).

The MCU provides a watchdog timer function to ensure graceful recovery from software malfunction. If it does not refresh watchdog timer before it reaches end-of-counter condition (overflow), then it activates the internal reset.

The S3F8S19/F8S15 has a built-in low voltage reset circuit. It provides detection of power voltage drop of external VDD input level to prevent MCU from malfunctioning in an unstable MCU power level. This voltage detector works for the reset operation of MCU. This low voltage reset includes an analog comparator and Vref circuit. Hardware internally sets the value of a detection voltage. The on-chip Low Voltage Reset, features static reset when supply voltage is below a reference voltage value (Typical 1.9/2.3/3.0/3.9 V). This feature can remove external reset circuit while keeping the application safe. As long as the supply voltage is below the reference value, an internal static RESET will be triggered. The MCU can start only when the supply voltage rises over the reference voltage.

When you calculate power consumption, remember that a static current of LVR circuit should be added a CPU operating current in any operating modes such as Stop, Idle, and normal RUN mode.

Figure 22-1 illustrates the low voltage reset circuit.

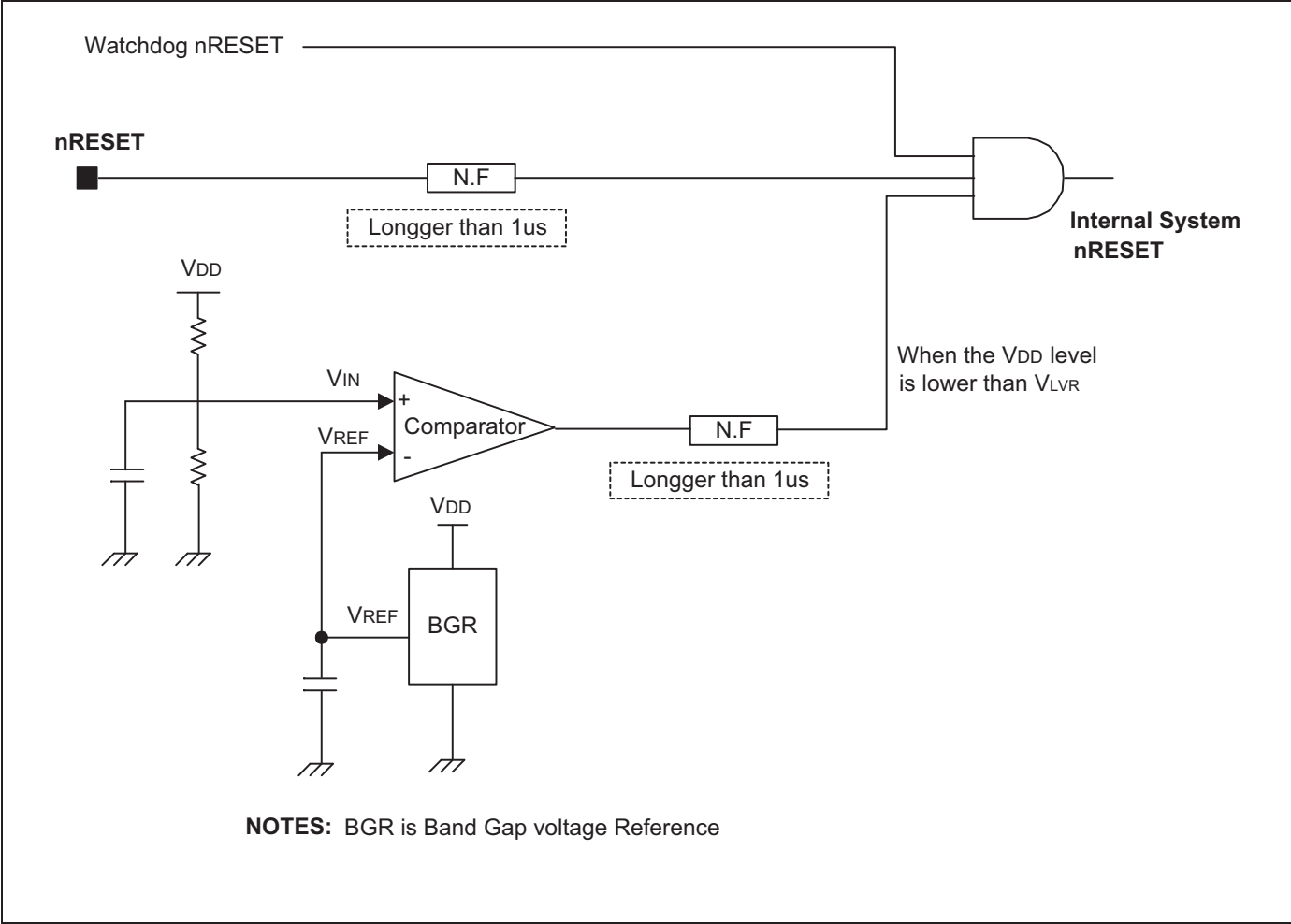


Figure 22-1 Low Voltage Reset Circuit

**NOTE:** To program the duration of the oscillation stabilization interval, make the appropriate settings to the basic timer control register, BTCON, before entering Stop mode. Also, if you do not want to use the basic timer watchdog function (which causes a system reset if a basic timer counter overflow occurs); disable it by writing "1010B" to the upper nibble of BTCON.

## 22.2 Low Voltage Detect

The S3F8S19/F8S15 micro-controller has a built-in Low Voltage Detector (LVD) circuit, which allows LVD interrupt and LVD\_FLAG detection of power voltage. The S3F8S19/F8S15 has four options in LVD voltage level according to the LVDCON register (Refer to [Figure 22-3](#) for more information).

- Low voltage detect level Flag Bit (LVD\_FLAG): 2.1 V, 2.5 V, 3.2V, 4.1 V (Typ)  $\pm$  100 mV

LVD block can be enabled or disabled by LVDCON.7. If you enable the LVD interrupt, when  $VDD < VLVD$ , an LVD interrupt generates.

The LVD block of S3F8S19/F8S15 consists of one comparator and a resistor string. The comparator is for LVD detection.

The comparator's output makes LVD indicator flag bit "1" or "0". That is used to indicate low voltage level. When the power voltage is below the LVD level, the bit 5 of LVDCON register is set "1". When the power voltage is above the LVD level, the bit 5 of LVDCON register is set "0" automatically. You can use LVDCON.5 flag bit to indicate low battery in applications.

[Figure 22-2](#) illustrates the block diagram of low voltage detect (LVD).

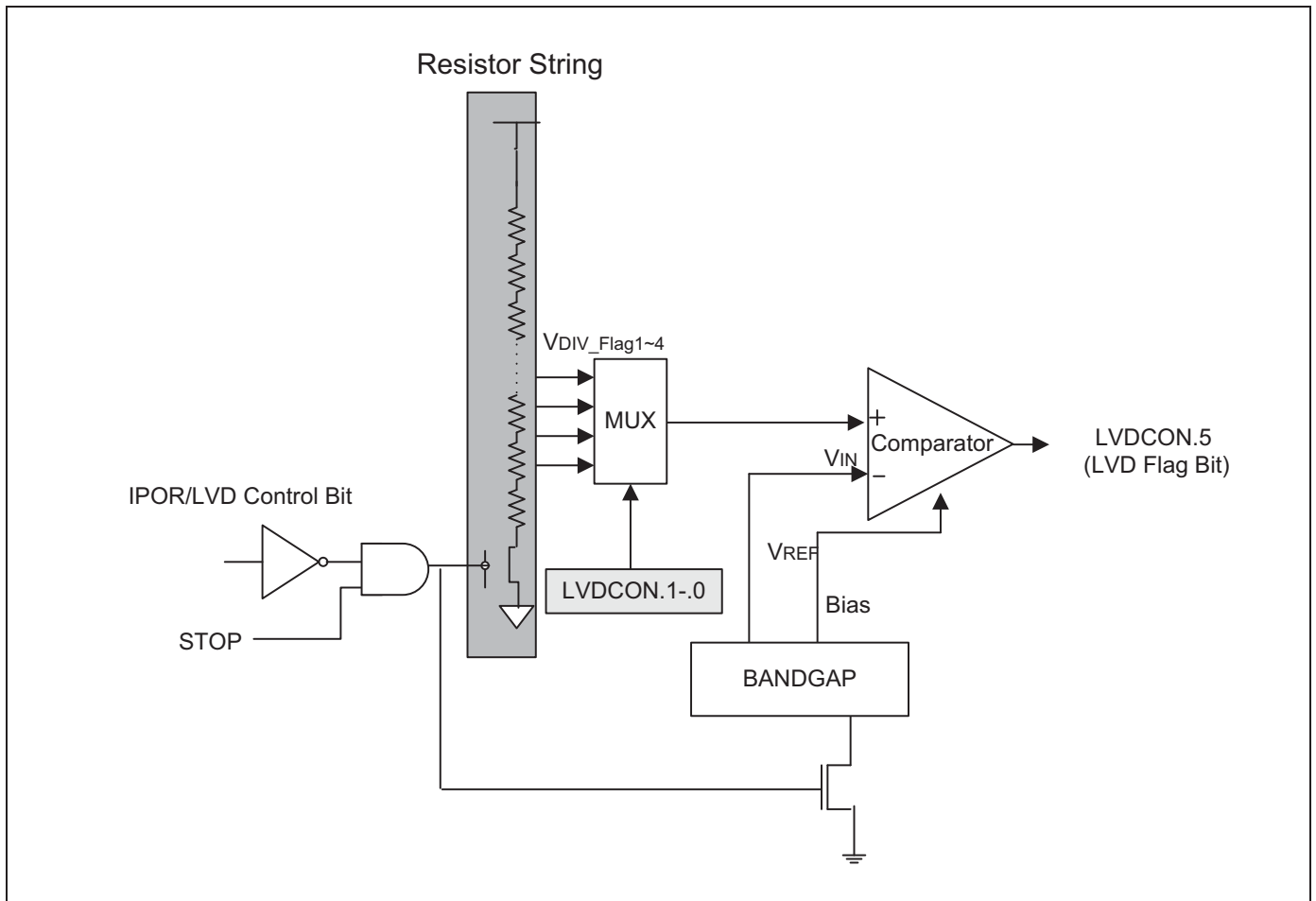
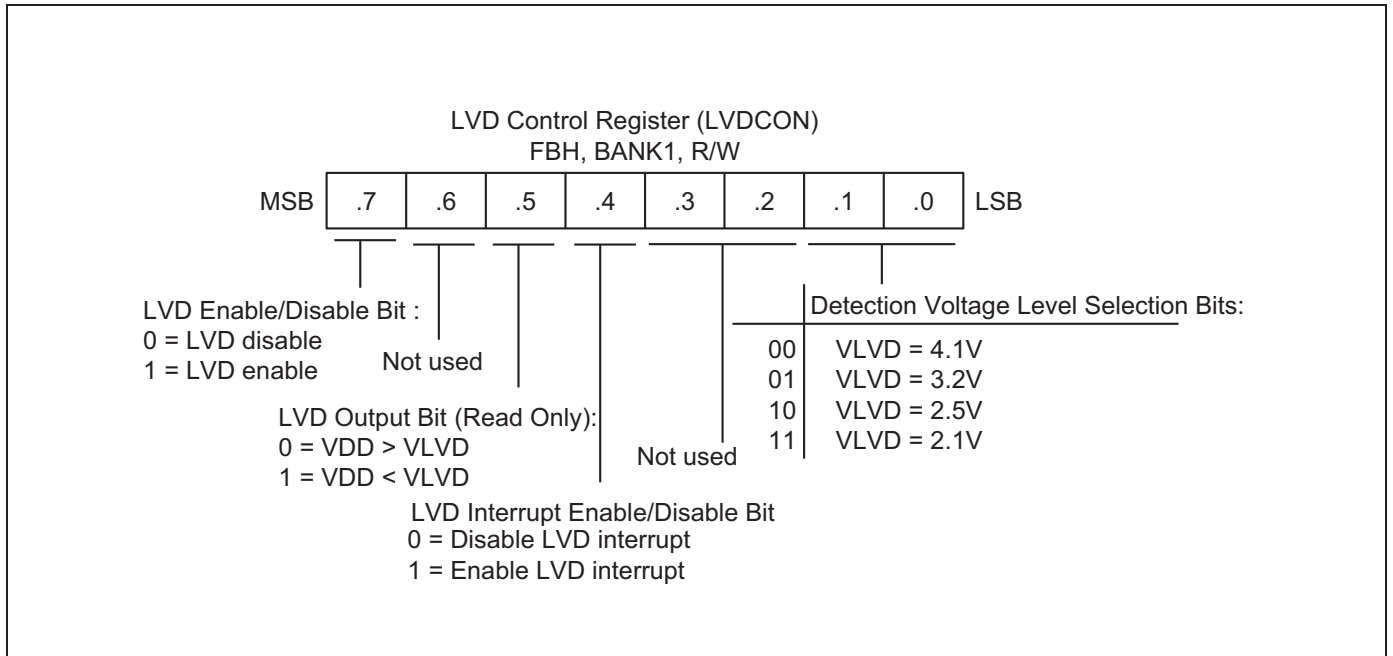


Figure 22-2 Low Voltage Detect (LVD) Block Diagram

Figure 22-3 illustrates the flash low voltage detect control register (LVDCON).



**Figure 22-3 Flash Low Voltage Detect Control Register (LVDCON)**

# 23 Electrical Data

## 23.1 Overview

This section includes the electrical characteristics of S3F8S19/F8S15, namely:

- Absolute maximum ratings
- Direct Current (D.C.) electrical characteristics
- Alternate current (A.C.) electrical characteristics
- Input timing measurement points
- Oscillator characteristics
- Oscillation stabilization time
- Operating voltage range
- Schmitt trigger input characteristics
- Data retention supply voltage in stop mode
- Stop mode release timing when initiated by a RESET
- Analog-to-digital (A/D) converter electrical characteristics
- Liquid Cristal Display (LCD) cap bias characteristics
- Universal Asynchronous Receiver/Transmitter (UART) characteristics
- Low Voltage Reset (LVR) circuit characteristics
- LVR reset timing
- Low Voltage Detect (LVD) circuit characteristics
- Full-Flash memory characteristics
- Electrostatic Discharge (ESD) Characteristics

This section presents these characteristics in tables and graphs.



## 23.2 Absolute Maximum Ratings

[Table 23-1](#) lists the absolute maximum ratings.

**Table 23-1 Absolute Maximum Ratings**

( $T_A = 25\text{ }^\circ\text{C}$ )

| Parameter             | Symbol    | Conditions                        | Rating                  | Unit             |
|-----------------------|-----------|-----------------------------------|-------------------------|------------------|
| Supply voltage        | $V_{DD}$  | –                                 | – 0.3 to + 6.5          | V                |
| Input voltage         | $V_I$     | All ports                         | – 0.3 to $V_{DD} + 0.3$ |                  |
| Output voltage        | $V_O$     | All output ports                  | – 0.3 to $V_{DD} + 0.3$ |                  |
| Output current high   | $I_{OH}$  | One Input/Output (I/O) pin active | – 25                    | mA               |
|                       |           | All I/O pins active               | – 80                    |                  |
| Output current low    | $I_{OL}$  | One I/O pin active                | + 30                    |                  |
|                       |           | All I/O pins active               | + 100                   |                  |
| Operating temperature | $T_A$     | –                                 | – 40 to + 85            | $^\circ\text{C}$ |
| Storage temperature   | $T_{STG}$ | –                                 | – 65 to +150            |                  |

## 23.3 DC Electrical Characteristics

Table 23-2 lists the DC electrical characteristics.

**Table 23-2 DC Electrical Characteristics**

( $T_A = -40\text{ }^\circ\text{C}$  to  $+85\text{ }^\circ\text{C}$ ,  $V_{DD} = 1.8\text{ V}$  to  $5.5\text{ V}$ )

| Parameter                         | Symbol            | Conditions   | Min.  | Typ.           | Max.           | Unit     |
|-----------------------------------|-------------------|--|---|----------------|----------------|----------|
| Operating voltage                 | V <sub>DD</sub>   | $T_A = -40\text{ }^\circ\text{C}$ to $+85\text{ }^\circ\text{C}$ | 1.8   | –              | 5.5            | V        |
| Main crystal or ceramic frequency | f <sub>main</sub> | $V_{DD} = 2.7\text{ V}$ to $5.5\text{ V}$                        | 0.4   | –              | 12             | MHz      |
|                                   |                   | $V_{DD} = 1.8\text{ V}$ to $2.7\text{ V}$                        | 0.4   | –              | 4              |          |
| Input high voltage                | V <sub>IH1</sub>  | Ports 0, 3   | $V_{DD} = 1.8$ to $5.5\text{ V}$                          | –              | $0.8 V_{DD}$   | $V_{DD}$ |
|                                   | V <sub>IH2</sub>  | Ports 1, 2, 4 and RESET  |   |                | $0.7 V_{DD}$   |          |
|                                   | V <sub>IH3</sub>  | X <sub>IN</sub>  |   |                | $V_{DD} - 0.1$ |          |
|                                   | V <sub>IH4</sub>  | XT <sub>IN</sub>   |   |                | –              |          |
| Input low voltage                 | V <sub>IL1</sub>  | Ports 0, 3   | $V_{DD} = 1.8$ to $5.5\text{ V}$                          | –              | $0.2 V_{DD}$   | V        |
|                                   | V <sub>IL2</sub>  | Ports 1, 2, 4 and RESET  |   |                | $0.3 V_{DD}$   |          |
|                                   | V <sub>IL3</sub>  | X <sub>IN</sub> and XT <sub>IN</sub>                             |   |                | 0.1            |          |
| Output high voltage               | V <sub>OH</sub>   | I <sub>OH</sub> = –1 mA<br>Ports 0, 1, 2, 3, 4                   | $V_{DD} = 4.5$ to $5.5\text{ V}$                          | $V_{DD} - 1.0$ | –              | –        |
| Output low voltage                | V <sub>OL</sub>   | I <sub>OL</sub> = 15 mA<br>Ports 0, 1, 2, 3, 4                   | $V_{DD} = 4.5$ to $5.5\text{ V}$                          | –              | 0.4            | 2.0      |
| Input high leakage current        | I <sub>LIH1</sub> | All input except I <sub>LIH2</sub>                               | $V_{IN} = V_{DD}$   | –              | –              | 1        |
|                                   | I <sub>LIH2</sub> | X <sub>IN</sub> , XT <sub>IN</sub>                               | $V_{IN} = V_{DD}$   | –              | –              | 20       |
| Input low leakage current         | I <sub>LIL1</sub> | All input except I <sub>LIL2</sub>                               | $V_{IN} = 0\text{ V}$                                     | –              | –              | –1       |
|                                   | I <sub>LIL2</sub> | X <sub>IN</sub> , XT <sub>IN</sub>                               | $V_{IN} = 0\text{ V}$                                     | –              | –              | –20      |
| Output high leakage current       | I <sub>LOH</sub>  | All output pins  | $V_{OUT} = V_{DD}$  | –              | –              | 2        |
| Output low leakage current        | I <sub>LOL</sub>  | All output pins  | $V_{OUT} = 0\text{ V}$                                    | –              | –              | –2       |
| Pull-up resistors                 | R <sub>DP1</sub>  | $V_{IN} = 0\text{ V}$ ,<br>Ports 0, 1, 2, 3, 4                   | $V_{DD} = 5\text{ V}$<br>$T_A = 25\text{ }^\circ\text{C}$ | 25             | 50             | 100      |
|                                   | R <sub>DP2</sub>  | $V_{IN} = 0\text{ V}$<br>nReset                                  | $V_{DD} = 5\text{ V}$<br>$T_A = 25\text{ }^\circ\text{C}$ | 125            | 250            | 500      |
| Supply current                    | I <sub>DD1</sub>  | Run mode<br>12MHz CPU clock                                      | $V_{DD} = 4.5$ to $5.5\text{ V}$                          | –              | 2.2            | 4        |
|                                   |                   | Run mode<br>4 MHz CPU clock                                      | $V_{DD} = 4.5$ to $5.5\text{ V}$                          | –              | 1.2            | 2        |
|                                   |                   | Run mode<br>4 MHz CPU clock                                      | $V_{DD} = 3.0\text{ V}$                                   | –              | 0.8            | 1.5      |
|                                   | I <sub>DD2</sub>  | Idle mode  | $V_{DD} = 4.5$ to $5.5\text{ V}$                          | –              | 1.3            | 2        |

| Parameter  | Symbol    | Conditions                   | Min.   | Typ. | Max. | Unit          |     |
|--|-----------|------------------------------|--|------|------|---------------|-----|
|  |           | 12 MHz CPU clock             |  |      |      | $\mu\text{A}$ |     |
|  |           | Idle mode<br>4 MHz CPU clock | $V_{DD} = 4.5 \text{ to } 5.5 \text{ V}$   |      | 0.8  |               | 1.5 |
|  |           | Idle mode<br>4 MHz CPU clock | $V_{DD} = 3.0\text{V}$   | –    | 0.4  |               | 0.8 |
|  | $I_{DD3}$ | Sub-Run                      | $V_{DD} = 3.0 \text{ V}$   | –    | 10   |               | 16  |
|  |           |                              | $V_{DD} = 3.0 \text{ V}$<br>(Cap bias LCD on)  | –    | 15   |               | 25  |
|  | $I_{DD4}$ | Sub-Idle                     | $V_{DD} = 3.0 \text{ V}$   | –    | 2.5  |               | 8   |
|  |           |                              | $V_{DD} = 3.0 \text{ V}$<br>(Cap bias LCD on)  | –    | 6    |               | 14  |
|  | $I_{DD5}$ | Stop mode                    | $V_{DD} = 4.5 \text{ to } 5.5\text{V}$   | –    | 0.6  |               | 4.5 |
|  |           |                              | $V_{DD} = 4.5 \text{ to } 5.5\text{V}$<br>(Ring OSC on,<br>STOP Wake-up<br>Timer on) |      | 1    |               | 5   |
| $V_{DD} = 4.5 \text{ to } 5.5\text{V}$<br>(LVR enable) |           |                              | 30   |      | 60   |               |     |

**NOTE:**

1. Supply current does not include current drawn through internal pull-up resistors, LCD voltage dividing resistors, ADC block, the LVR block, LVD block, and external output current loads.
2.  $I_{DD1}$  and  $I_{DD2}$  include power consumption for sub clock oscillation.
3.  $I_{DD3}$  and  $I_{DD4}$  are current when main clock oscillation stops and the sub clock issued.
4.  $I_{DD5}$  is current when main and sub clock oscillation stops.

## 23.4 AC Electrical Characteristics

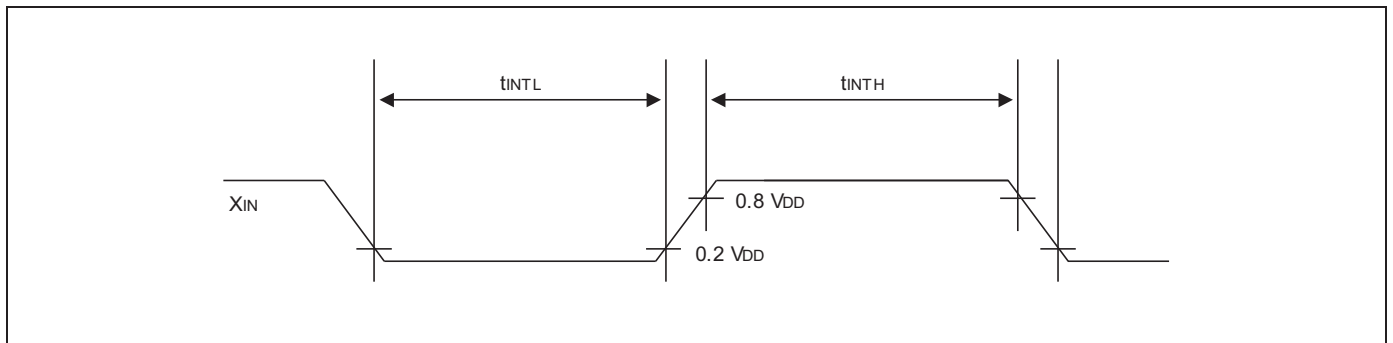
[Table 23-3](#) lists the AC electrical characteristics.

**Table 23-3 AC Electrical Characteristics**

( $T_A = -40\text{ }^\circ\text{C}$  to  $+85\text{ }^\circ\text{C}$ ,  $V_{DD} = 1.8\text{ V}$  to  $5.5\text{ V}$ )

| Parameter                       | Symbol                   | Conditions                                  | Min. | Typ. | Max. | Unit          |
|---------------------------------|--------------------------|---|------|------|------|---------------|
| Interrupt input high, low width | $t_{INTH}$<br>$t_{INTL}$ | INT0-INT7<br>$V_{DD} = 5\text{ V} \pm 10\%$ | 500  | –    | –    | ns            |
| RESET input low width           | $t_{RSL}$                | Input<br>$V_{DD} = 5\text{ V} \pm 10\%$     | 10   | –    | –    | $\mu\text{s}$ |

[Figure 23-1](#) illustrates the input timing measurement points.



**Figure 23-1 Input Timing Measurement Points**

## 23.5 Oscillator Characteristics

[Table 23-4](#) lists the oscillator characteristics.

**Table 23-4 Oscillator Characteristics**

( $T_A = -40\text{ }^\circ\text{C}$  to  $+85\text{ }^\circ\text{C}$ ,  $V_{DD} = 1.8\text{ V}$  to  $5.5\text{ V}$ )

| Oscillator  | Clock Circuit | Test Condition   | Min.   | Typ.      | Max.      | Unit |
|---|---------------|--|--------|-----------|-----------|------|
| Main crystal or ceramic                                   |               | $V_{DD} = 2.7$ to $5.5\text{ V}$                                     | 0.4    | –         | 12        | MHz  |
|   |               | $V_{DD1} = 1.8$ to $2.7\text{ V}$                                    | 0.4    | –         | 4         |      |
| External clock<br>(Main System)                           |               | $V_{DD} = 2.7$ to $5\text{ V}$                                       | 0.4    | –         | 12        | MHz  |
|   |               | $V_{DD} = 1.8$ to $2.7\text{ V}$                                     | 0.4    | –         | 4         |      |
| Tolerance of internal<br>RC oscillator<br>(8/4/2/0.5 MHz) | –             | $T_A = 25\text{ }^\circ\text{C}$<br>$V_{DD} = 1.8$ to $5.0\text{ V}$ | –      | $\pm 0.5$ | $\pm 1$   | %    |
|   |               | $T_A = -40\text{ }^\circ\text{C}$ to $+85\text{ }^\circ\text{C}$     | –      | –         | $\pm 3.5$ |      |
| Internal Ring oscillator<br>(OSC)                         | –             | $V_{DD} = 5\text{ V}$ , $T_A = 25\text{ }^\circ\text{C}$             | 16.384 | 32.768    | 49.152    | KHz  |
| External sub crystal                                      | –             | –  | –      | 32.768    | –         |      |
| External RC oscillator                                    | –             | $V_{DD} = 5\text{ V}$  | –      | 4         | –         |      |

**NOTE:**

1. Refer to the figure of Operating Voltage Range for more information.
2. For user calibration of internal RC oscillator, refer to Chapter 7 for more information.

Table 23-5 lists the oscillation stabilization point.

**Table 23-5 Oscillation Stabilization Time**

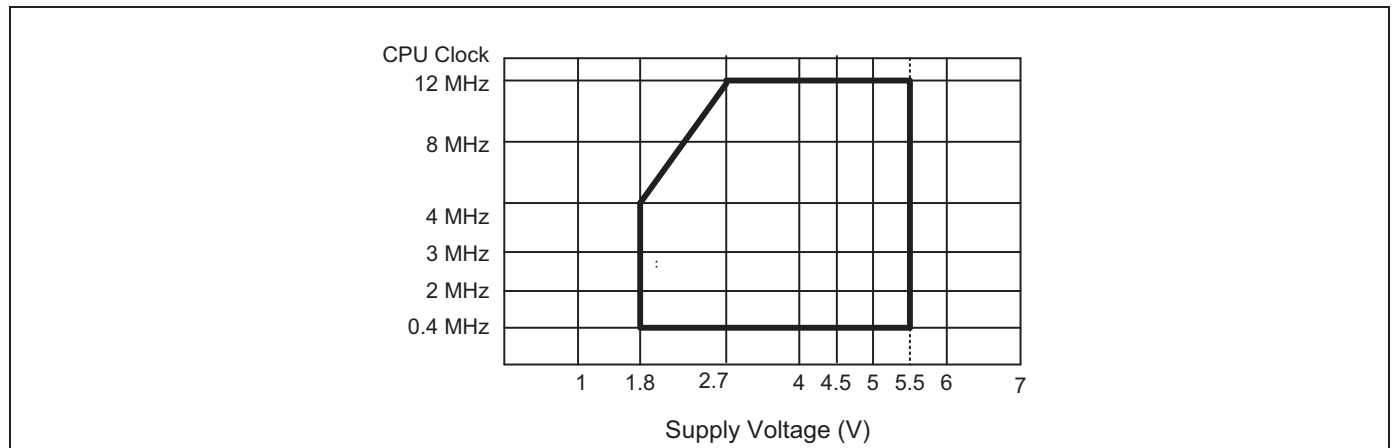
( $T_A = -40\text{ }^\circ\text{C}$  to  $+85\text{ }^\circ\text{C}$ ,  $V_{DD} = 1.8\text{ V}$  to  $5.5\text{ V}$ )

| Oscillator                         | Test Condition   | Min. | Typ.             | Max. | Unit |
|------------------------------------|--|------|------------------|------|------|
| Main crystal                       | $f_{OSC} > 1.0\text{ MHz}$   | –    | –                | 20   | ms   |
| Main ceramic                       | Oscillation stabilization occurs when $V_{DD}$ is equal to the minimum oscillator voltage range. | –    | –                | 10   |      |
| External clock (main system)       | $X_{IN}$ input high and low width ( $t_{XH}$ , $t_{XL}$ )  | 25   | –                | 500  | ns   |
| Oscillator stabilization wait time | $t_{WAIT}$ when released by a reset <sup>(1)</sup>   | –    | $2^{19}/f_{OSC}$ | –    | ms   |
|                                    | $t_{WAIT}$ when released by an interrupt <sup>(2)</sup>  | –    | –                | –    |      |
| Sub oscillator stabilization time  | –  | –    | –                | 10   | s    |

**NOTE:**

- $f_{OSC}$  is the oscillator frequency.
- The duration of the oscillator stabilization wait time,  $t_{WAIT}$ , when it is released by an interrupt, is determined by the settings in the basic timer control register, BTCON.

Figure 23-2 illustrates the operating voltage range.



**Figure 23-2 Operating Voltage Range**

[Table 23-6](#) lists the data retention supply voltage in stop mode.

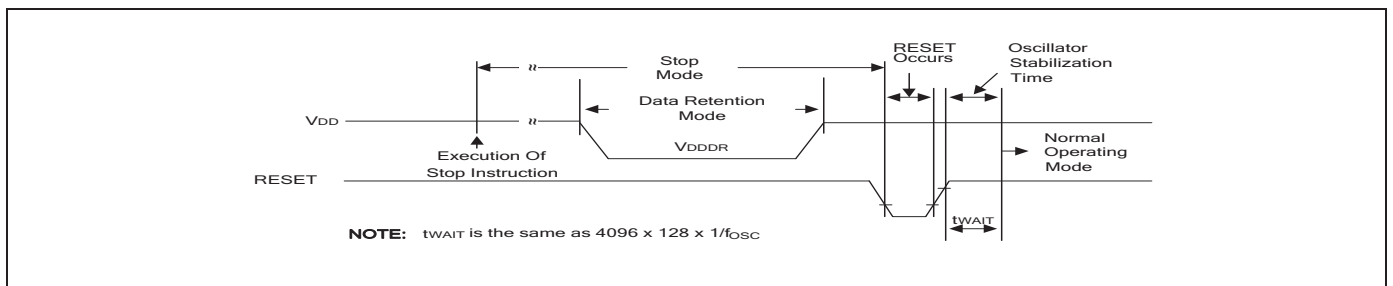
**Table 23-6 Data Retention Supply Voltage in Stop Mode**

( $T_A = -40\text{ }^\circ\text{C}$  to  $+85\text{ }^\circ\text{C}$ ,  $V_{DD} = 1.8\text{ V}$  to  $5.5\text{ V}$ )

| Parameter                     | Symbol     | Conditions                           | Min. | Typ. | Max. | Unit          |
|-------------------------------|------------|--------------------------------------|------|------|------|---------------|
| Data retention supply voltage | $V_{DDDR}$ | Stop mode                            | 1.0  | –    | 5.5  | V             |
| Data retention supply current | $I_{DDDR}$ | Stop mode; $V_{DDDR} = 2.0\text{ V}$ | –    | –    | 1    | $\mu\text{A}$ |

**NOTE:** Supply current does not include current drawn through internal pull-up resistors or external output current loads.

[Figure 23-3](#) illustrates the stop mode release timing when reset initiates it.



**Figure 23-3 Stop Mode Release Timing When Initiated by a RESET**

Table 23-7 lists the A/D converter electrical characteristics.

**Table 23-7 A/D Converter Electrical Characteristics**

( $T_A = -40\text{ }^\circ\text{C}$  to  $+85\text{ }^\circ\text{C}$ ,  $V_{DD} = 1.8\text{ V}$  to  $5.5\text{ V}$ ,  $V_{SS} = 0\text{ V}$ )

| Parameter                           | Symbol     | Test Conditions   | Min.     | Typ.    | Max.                   | Unit             |
|-------------------------------------|------------|---|----------|---------|------------------------|------------------|
| Resolution                          | –          | –   | –        | 10      | –                      | bit              |
| Total accuracy                      | –          | $V_{DD} = 5.12\text{ V}$<br>CPU clock = 10 MHz<br>$V_{SS} = 0\text{ V}$ | –        | –       | $\pm 3$ <sup>(1)</sup> | LSB              |
| Integral linearity error            | ILE        | –   | –        | –       | $\pm 2$                |                  |
| Differential linearity error        | DLE        | –   | –        | –       | $\pm 1$                |                  |
| Offset error of top                 | EOT        | –   | –        | $\pm 1$ | $\pm 3$                |                  |
| Offset error of bottom              | EOB        | –   | –        | $\pm 1$ | $\pm 3$                |                  |
| Conversion time <sup>(2)</sup>      | $T_{ON}$   | –   | –        | 20      | –                      | $\mu\text{s}$    |
| Analog input voltage                | $V_{IAN}$  | –   | $V_{SS}$ | –       | $V_{DD}$               | V                |
| Analog input impedance              | $R_{AN}$   | –   | 2        | 1000    | –                      | $\text{M}\Omega$ |
| Analog input current                | $I_{ADIN}$ | $V_{DD} = 5\text{ V}$   | –        | –       | 10                     | $\mu\text{A}$    |
| Analog block current <sup>(3)</sup> | $I_{ADC}$  | $V_{DD} = 5\text{ V}$   | –        | 0.5     | 1.5                    | mA               |
|                                     |            | $V_{DD} = 3\text{ V}$   |          | 0.15    | 0.45                   |                  |
|                                     |            | $V_{DD} = 5\text{ V}$<br>power down mode                                | –        | 100     | 500                    | nA               |

**NOTE:**

1. The total accuracy is 3LSB (maximum) at  $V_{DD} = 2.7\text{ V}$ – $5.5\text{ V}$ , It is for design guidance only and are not tested in production.
2. "Conversion time" is the time required from the moment a conversion operation starts until it ends.
3.  $I_{ADC}$  is operating current during A/D conversion.



Table 23-8 lists the capacitor bias electrical characteristics.

**Table 23-8 Capacitor Bias Electrical Characteristics**

( $T_A = -40\text{ }^\circ\text{C}$  to  $+85\text{ }^\circ\text{C}$  at  $V_{DD} = 1.8\text{ V}$  to  $5.5\text{ V}$ )

| Parameter                    | Symbol  | Conditions  | Min.                               | Typ.                               | Max.                               | Unit                     |   |
|------------------------------|---|---|------------------------------------|------------------------------------|------------------------------------|--------------------------|---|
| Liquid crystal drive voltage | $V_{LC3}$   | Connects a $0.1\text{ }\mu\text{F}$ load capacitor between $V_{LC3}$ and $V_{SS}$ (No panel load) | LMOD.2-.0 = 0                      | Typical $\times$<br>0.85           | 0.90                               | Typical $\times$<br>1.15 | V |
|                              |   |   | LMOD.2-.0 = 1                      |                                    | 0.95                               |                          |   |
|                              |   |   | LMOD.2-.0 = 2                      |                                    | 1.00                               |                          |   |
|                              |   |   | LMOD.2-.0 = 3                      |                                    | 1.05                               |                          |   |
|                              |   |   | LMOD.2-.0 = 4                      |                                    | 1.10                               |                          |   |
|                              |   |   | LMOD.2-.0 = 5                      |                                    | 1.15                               |                          |   |
|                              |   |   | LMOD.2-.0 = 6                      |                                    | 1.20                               |                          |   |
|                              |   |   | LMOD.2-.0 = 7                      |                                    | 1.25                               |                          |   |
|                              | $V_{LC2}$   | Connects a $0.1\text{ }\mu\text{F}$ load capacitor between $V_{LC2}$ and $V_{SS}$ (No panel load) | $2 \times V_{LC3}$<br>$\times 0.9$ | –                                  | $2 \times V_{LC3}$<br>$\times 1.1$ |                          |   |
|                              | $V_{LC1}$   | Connects a $0.1\text{ }\mu\text{F}$ load capacitor between $V_{LC1}$ and $V_{SS}$ (No panel load) | $3 \times V_{LC3}$<br>$\times 0.9$ | –                                  | $3 \times V_{LC3}$<br>$\times 1.1$ |                          |   |
| $V_{LC0}$                    | Connects a $0.1\text{ }\mu\text{F}$ load capacitor between $V_{LC0}$ and $V_{SS}$ (No panel load) | $4 \times V_{LC3}$<br>$\times 0.9$  | –                                  | $4 \times V_{LC3}$<br>$\times 1.1$ |                                    |                          |   |

Table 23-9 lists the UART timing characteristics in mode 0 (10 MHz).

**Table 23-9 UART Timing Characteristics in Mode 0 (10 MHz)**

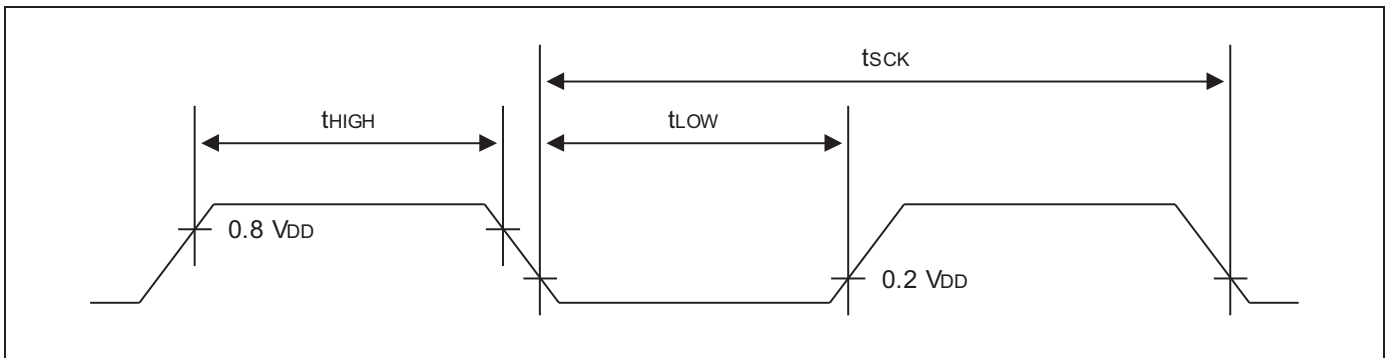
( $T_A = -40\text{ }^\circ\text{C}$  to  $+85\text{ }^\circ\text{C}$ , 1.8 V to 5.5 V, Load capacitance = 80 pF)

| Parameter                                | Symbol              | Min.           | Typ.               | Max. | Unit |
|--|---------------------|----------------|--------------------|------|------|
| Serial port clock cycle time             | $t_{SCK}$           | 500            | $T_{0PU} \times 6$ | 700  | ns   |
| Output data setup to clock rising edge   | $t_{S1}$            | 300            | $T_{0PU} \times 5$ | –    |      |
| Clock rising edge to input data valid    | $t_{S2}$            | –              | –                  | 300  |      |
| Output data hold after clock rising edge | $t_{H1}$            | $T_{0PU} - 50$ | $T_{0PU}$          | –    |      |
| Input data hold after clock rising edge  | $t_{H2}$            | 0              | –                  | –    |      |
| Serial port clock high, low-level width  | $t_{HIGH}, t_{LOW}$ | 200            | $T_{0PU} \times 3$ | 400  |      |

**NOTE:**

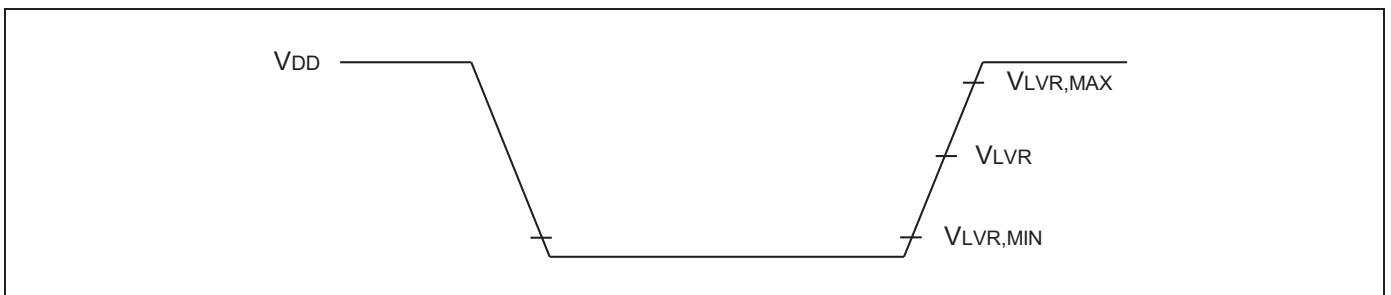
1. All timings are in nanoseconds (ns) and assume a 10 MHz CPU clock frequency.
2. The unit  $T_{0PU}$  means one CPU clock period.

Figure 23-4 illustrates the waveform for UART timing characteristics.



**Figure 23-4 Waveform for UART Timing Characteristics**

Figure 23-5 illustrates the LVR reset timing.



**Figure 23-5 LVR Reset Timing**

[Table 23-10](#) lists the flash memory AC electrical characteristics.

**Table 23-10 Flash Memory AC Electrical Characteristics**

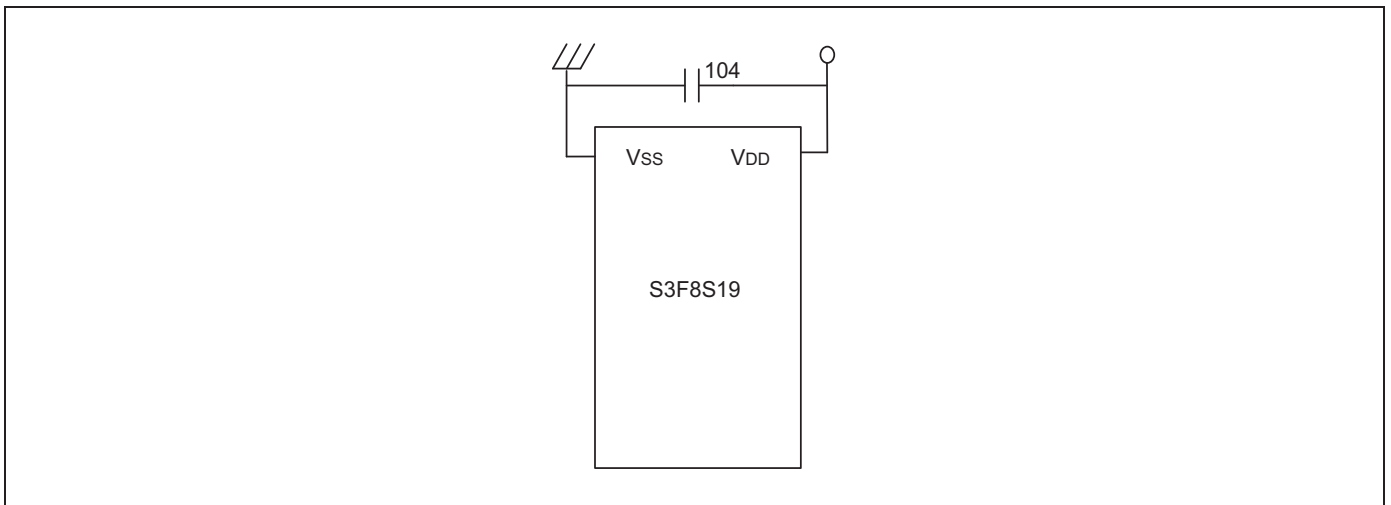
( $T_A = -40\text{ }^\circ\text{C}$  to  $+85\text{ }^\circ\text{C}$  at  $V_{DD} = 1.8\text{ V}$  to  $5.5\text{ V}$ )

| Parameter                          | Symbol    | Conditions             | Min.   | Typ. | Max. | Unit          |
|------------------------------------|-----------|------------------------|--------|------|------|---------------|
| Flash Erase/Write/Read Voltage     | Fewrv     | $V_{DD}$               | 1.8    | 5.0  | 5.5  | V             |
| Programming time <sup>(1)</sup>    | Ftp       | –                      | 20     | –    | 30   | $\mu\text{s}$ |
| Chip Erasing time <sup>(2)</sup>   | Ftp1      |                        | 32     | –    | 70   | ms            |
| Sector Erasing time <sup>(3)</sup> | Ftp2      |                        | 4      | –    | 12   |               |
| Data Access Time                   | $F_{tRS}$ | $V_{DD} = 2.0\text{V}$ | –      | 250  | –    | ns            |
| Number of writing/erasing          | FNwe      | –                      | 10,000 | –    | –    | Times         |
| Data Retention                     | Ftdr      | –                      | 10     | –    | –    | Years         |

**NOTE:**

1. The programming time is the time during which one byte (8-bit) is programmed.
2. The Chip erasing time is the time during which entire program memory is erased.
3. The Sector erasing time is the time during which all 128 byte block is erased.
4. The chip erasing is available in Tool Program Mode only.

[Figure 23-6](#) illustrates the circuit diagram to improve EFT characteristics.



**Figure 23-6 The Circuit Diagram to Improve EFT Characteristics**

**NOTE:** To improve EFT characteristics, use power capacitor near S3F8S19/F8S15 as illustrated in [Figure 23-6](#).

[Table 23-11](#) lists the ESD characteristics.

**Table 23-11 ESD Characteristics**

| Parameter               | Symbol    | Conditions | Min. | Typ. | Max. | Unit |
|-------------------------|-----------|------------|------|------|------|------|
| Electrostatic discharge | $V_{ESD}$ | HBM        | 2000 | –    | –    | V    |
|                         |           | MM         | 200  | –    | –    |      |
|                         |           | CDM        | 500  | –    | –    |      |

[Table 23-12](#) lists the LVD circuit characteristics.

**Table 23-12 LVD Circuit Characteristics**

( $T_A = -40$  to  $85$  °C,  $V_{DD} = 1.8$  V to  $5.5$  V)

| Parameter          | Symbol     | Conditions | Min. | Typ. | Max. | Unit |
|--------------------|------------|------------|------|------|------|------|
| LVD Detect Voltage | $V_{LVD0}$ | –          | 4.0  | 4.1  | 4.2  | V    |
|                    | $V_{LVD1}$ |            | 3.1  | 3.2  | 3.3  |      |
|                    | $V_{LVD2}$ |            | 2.4  | 2.5  | 2.6  |      |
|                    | $V_{LVD3}$ |            | 2.0  | 2.1  | 2.2  |      |

[Table 23-13](#) lists the LVR circuit characteristics.

**Table 23-13 LVR Circuit Characteristics**

( $T_A = -40$  to  $85$  °C,  $V_{DD} = 1.8$  V to  $5.5$  V)

| Parameter          | Symbol     | Conditions | Min. | Typ. | Max. | Unit |
|--------------------|------------|------------|------|------|------|------|
| LVR Detect Voltage | $V_{LVR0}$ | –          | 3.8  | 3.9  | 4.0  | V    |
|                    | $V_{LVR1}$ |            | 2.9  | 3.0  | 3.1  |      |
|                    | $V_{LVR2}$ |            | 2.2  | 2.3  | 2.4  |      |
|                    | $V_{LVR3}$ |            | 1.8  | 1.9  | 2.0  |      |

# 24 Mechanical Data

## 24.1 Overview

The S3F8S19/F8S15 is available in these packages:

- 48-pin Quad Flat Package (QFP) (Samsung: 48-QFP-1010E)

Package dimensions are illustrated in [Figure 24-1](#).

[Figure 24-1](#) illustrates the package dimensions of 48-pin Quad Flat Package (QFP) (Samsung: 48-QFP-1010E).

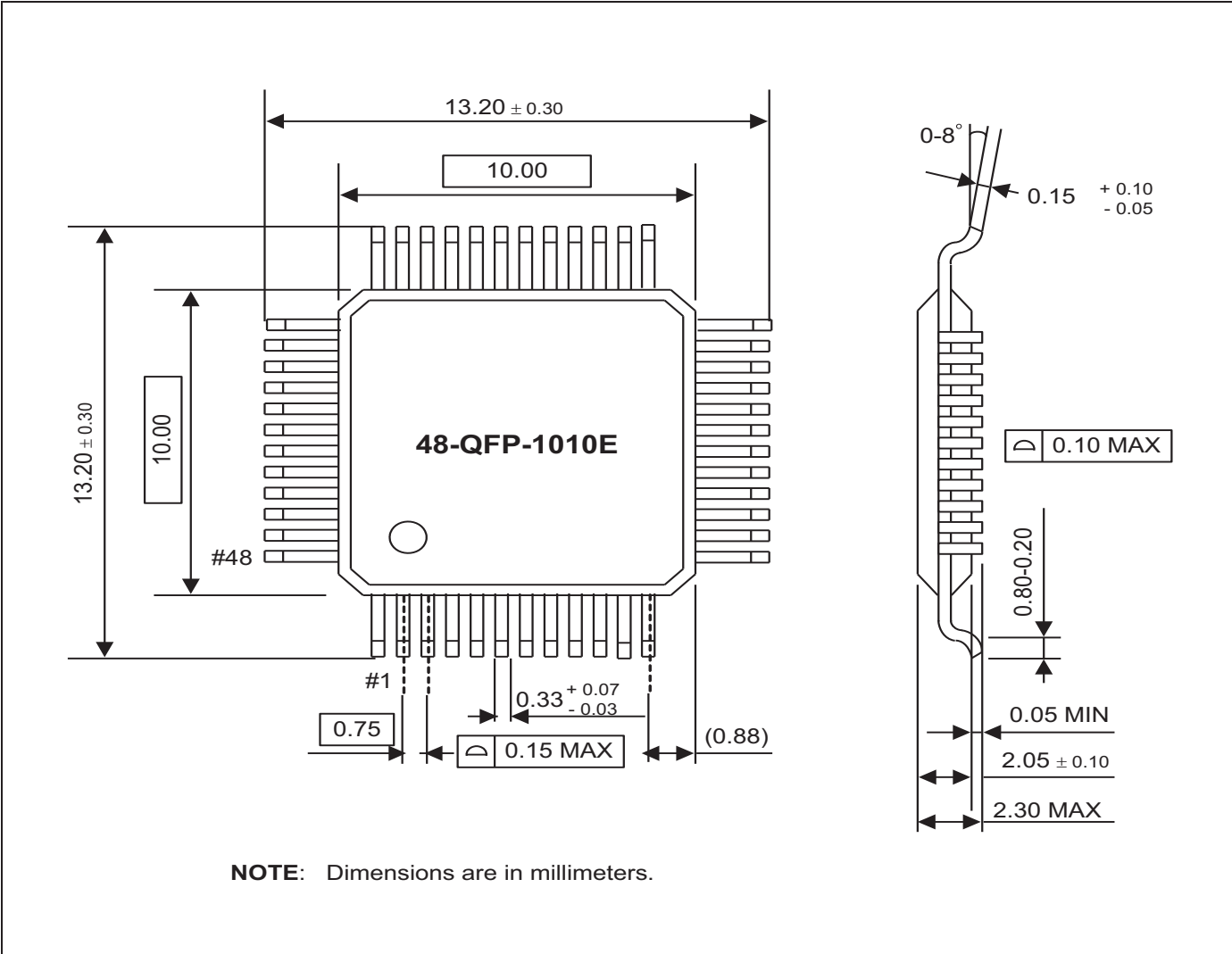


Figure 24-1 48-QFP-1010E Package Dimensions

# 25

## S3F8S19/F8S15 Flash MCU

### 25.1 Overview

The S3F8S19/F8S15 single-chip CMOS microcontroller is the Flash MCU. It has an on-chip Flash MCU Read Only Memory (ROM). The Flash ROM is accessed by serial data format.

**NOTE:** This chapter is about the Tool Program Mode of Flash MCU. Refer to Chapter 21 Embedded Flash Memory Interface, to know more information about the User Program Mode.

## 25.2 Pin Assignments

Figure 25-1 illustrates the S3F8S19/F8S15 pin assignments.

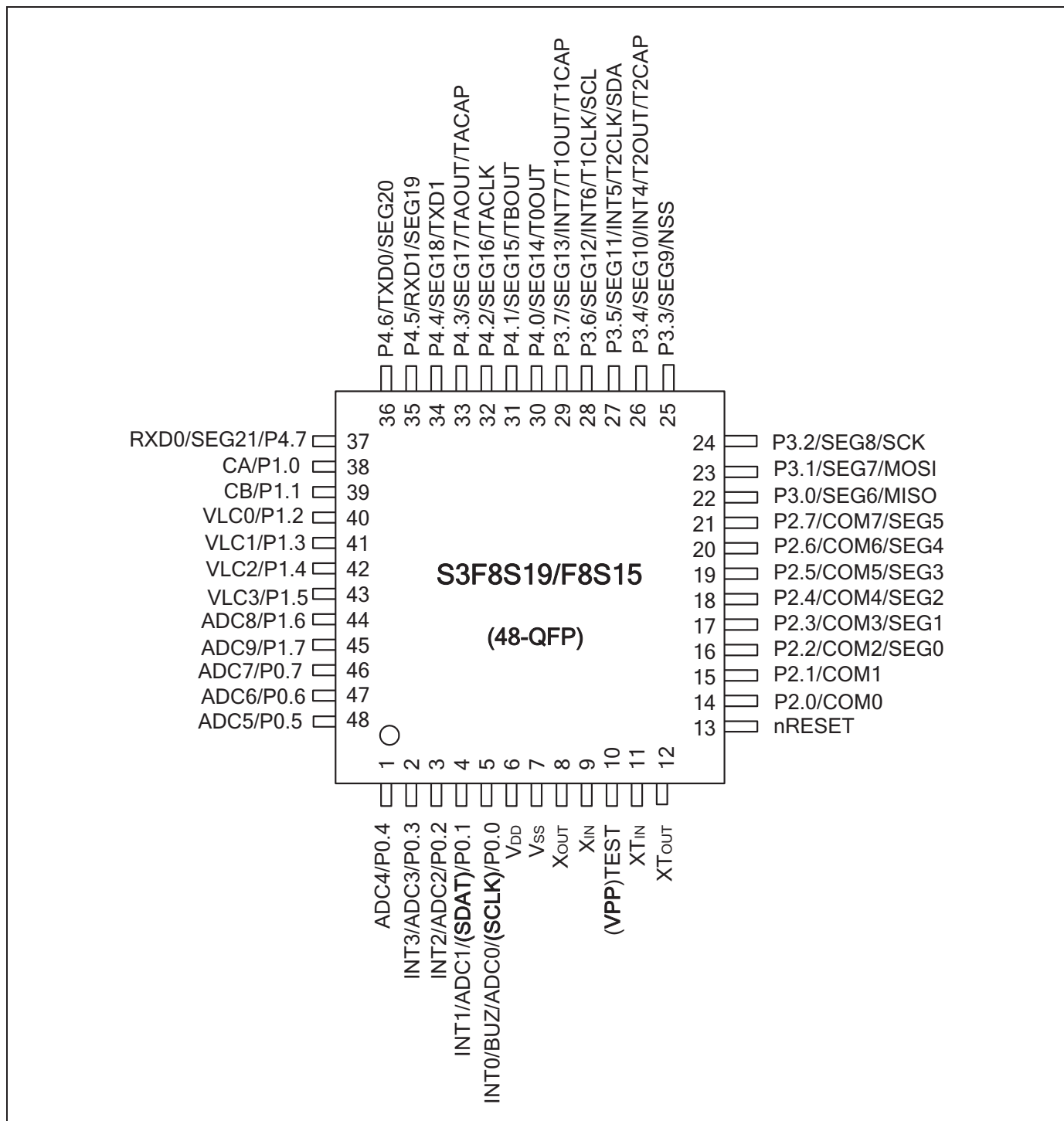


Figure 25-1 S3F8S19/F8S15 Pin Assignments (48-QFP-1010E)

[Table 25-1](#) describes the pins used to read/write the flash in tool program mode.

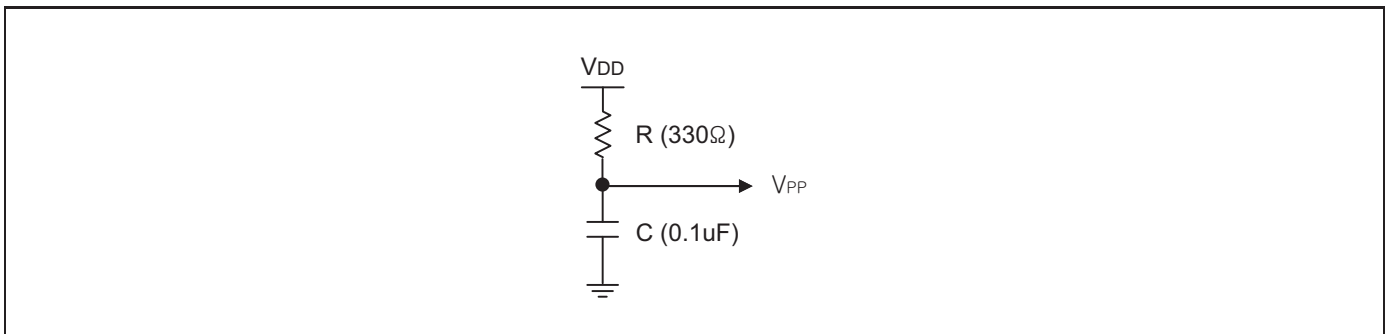
**Table 25-1 Descriptions of Pins Used to Read/Write the Flash in Tool Program mode**

| Normal Chip                       | During Programming                |         |     |   |
|-----------------------------------|-----------------------------------|---------|-----|---|
| Pin Name                          | Pin Name                          | Pin No. | I/O | Function  |
| P0.1                              | SDAT                              | 4       | I/O | Serial data pin.<br>Output port when reading and input port when writing. Can be assigned as an input or push-pull output port.   |
| P0.0                              | SCLK                              | 5       | I   | Serial clock pin. Input only pin.   |
| TEST                              | Vpp                               | 10      | I   | Tool mode selection when TEST/Vpp pin sets Logic value "1".<br>When you use the flash writer tool mode (ex.spw2+ etc...), you should connect TEST/VPP pin to VDD. (S3F8S19/F8S15 supplies high voltage 11 V by internal high voltage generation circuit.) |
| nRESET                            | nRESET                            | 13      | I   | Chip Initialization   |
| V <sub>DD</sub> , V <sub>SS</sub> | V <sub>DD</sub> , V <sub>SS</sub> | 6<br>7  | —   | Power supply pin for logic circuit.<br>You should tie V <sub>DD</sub> to 5.0 V during programming.  |

### Test Pin Voltage

The TEST pin on socket board for MTP writer must be connected to VDD (5.0 V) with RC delay as illustrated in [Figure 25-2](#) (only when SPW 2+ and GW-pro2 are used). The TEST pin on socket board must not be connected Vpp (5.0 V) which is generated from MTP Writer. Therefore, when you write or erase using MTP writer, you should use the specific socket board for S3F8S39/38/35/34.

[Figure 25-2](#) illustrates the RC delay circuit.



**Figure 25-2 RC Delay Circuit**



## 25.3 On Board Writing

The S3F8S19/F8S15 needs only 6 signal lines that include  $V_{DD}$  and  $V_{SS}$  pins for writing internal flash memory with serial protocol. Therefore, the on-board writing is possible if the writing signal lines are considered when the PCB of application board is designed.

### 25.3.1 Circuit Design Guide

At the flash writing, the writing tool needs 6 signal lines that are  $V_{SS}$ ,  $V_{DD}$ , nRESET, TEST, SDAT and SCLK. When you design the PCB circuits, you should consider the usage of these signal lines for the on-board writing.

In case of TEST pin, normally test pin is connected to  $V_{SS}$ , but in writing mode, a resistor should be inserted between the TEST pin and  $V_{SS}$ . You should treat nRESET, SDAT, and SCLK under the same consideration.

You should be careful to design the circuit that these signal pins relate because rising/falling timing of  $V_{PP}$ , SCLK, and SDAT is very important for proper programming.

[Figure 25-3](#) illustrates the PCB design guide for on board programming.

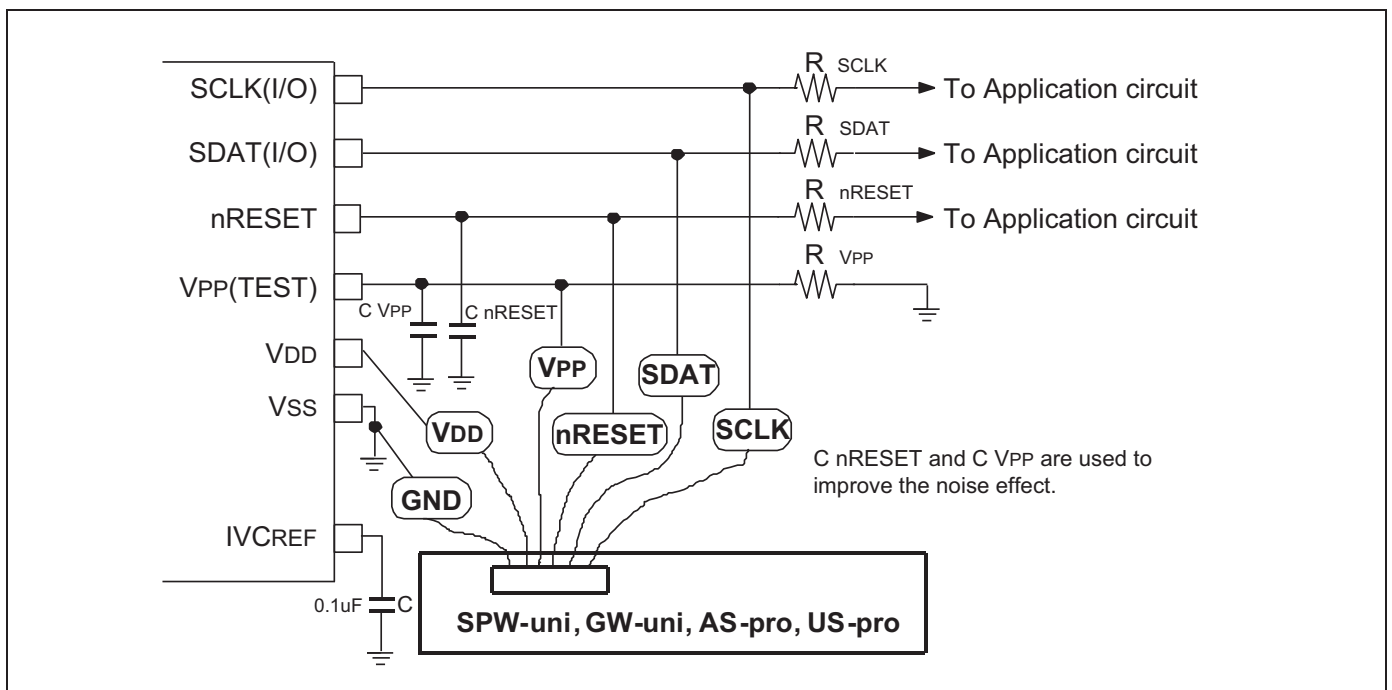


Figure 25-3 PCB Design Guide for on Board Programming

### 25.3.2 Reference Table for Connection

[Table 25-2](#) describes the reference table for connection.

**Table 25-2 Reference Table for Connection**

| Pin Name               | I/O Mode in Applications | Resistor (Need) | Required Value   |
|------------------------|--------------------------|-----------------|--|
| V <sub>PP</sub> (TEST) | Input                    | Yes             | RV <sub>pp</sub> is 10 kΩ to 50 kΩ.<br>CV <sub>pp</sub> is 0.01 μF to 0.02 μF. |
| nRESET                 | Input                    | Yes             | RnRESET is 2 kΩ to 5 kΩ.<br>CnRESET is 0.01 μF to 0.02 μF.                     |
| SDAT (I/O)             | Input                    | Yes             | RSDAT is 2 kΩ to 5 kΩ.   |
|                        | Output                   | No (NOTE)       | –  |
| SCLK (I/O)             | Input                    | Yes             | RSCLK is 2 kΩ to 5 kΩ.   |
|                        | Output                   | No (NOTE)       | –  |

**NOTE:** In the on-board writing mode, very high-speed signal will be provided to pin SCLK and SDAT. It also causes some damages to the application circuits connected to SCLK or SDAT port if the application circuit is designed as high-speed response such as relay control circuit. If possible, set the Input/Output (I/O) configuration of SDAT, SCLK pins to input mode.

The value of R, C in this table is a recommended value. It varies with circuit of system.

# 26

## Development Tools

### 26.1 Overview

Samsung provides a powerful and easy-to-use development support system on a turnkey basis. The development support system consists of a host system, debugging tools, and supporting software. For a host system, you can use any standard computer that employs Win95/98/2000/XP as its operating system. Samsung provides sophisticated debugging tool both in hardware and software: the powerful in-circuit emulator, OPENice-i500/i2000 and SK-1200, for the S3F7-, S3F9-and S3F8- microcontroller families. Samsung also offers supporting software that includes debugger, an assembler, and a program for setting options.

#### 26.1.1 Target Boards

Target boards are available for all the S3C8/S3F8-series microcontrollers. All the target system cables and adapters that user requires, it includes on the device-specific target board. TB8S19/8S28/8S39 is a specific target board for the development of application systems using S3F8S19/F8S15.

#### 26.1.2 Programming Socket Adapter

When you program S3F8S19/F8S15's flash memory by using an emulator or OTP/MTP writer, you require a specific programming socket adapter for S3F8S19/F8S15.

[Development System Configuration]

Figure 26-1 illustrates the development system configuration.

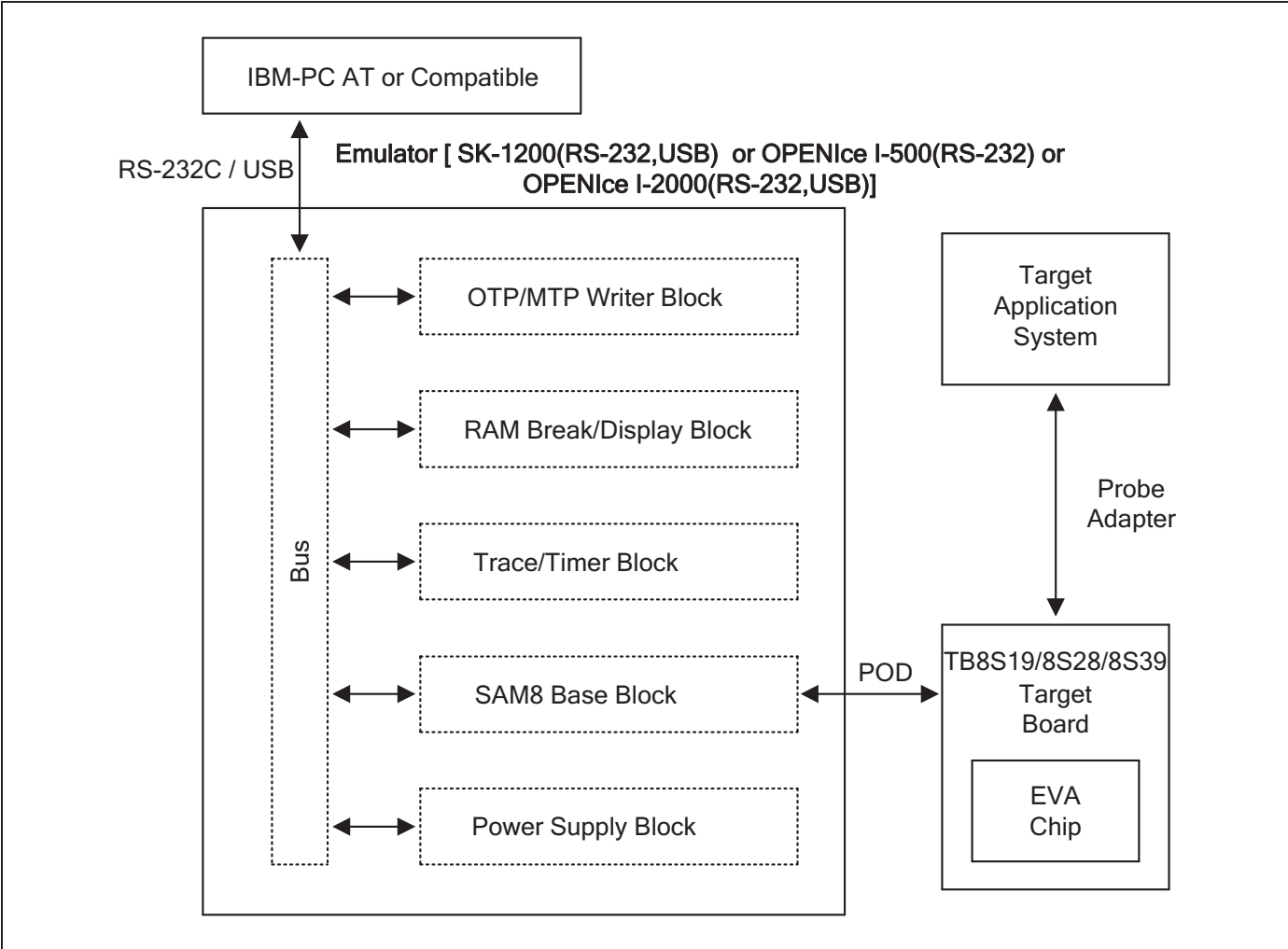
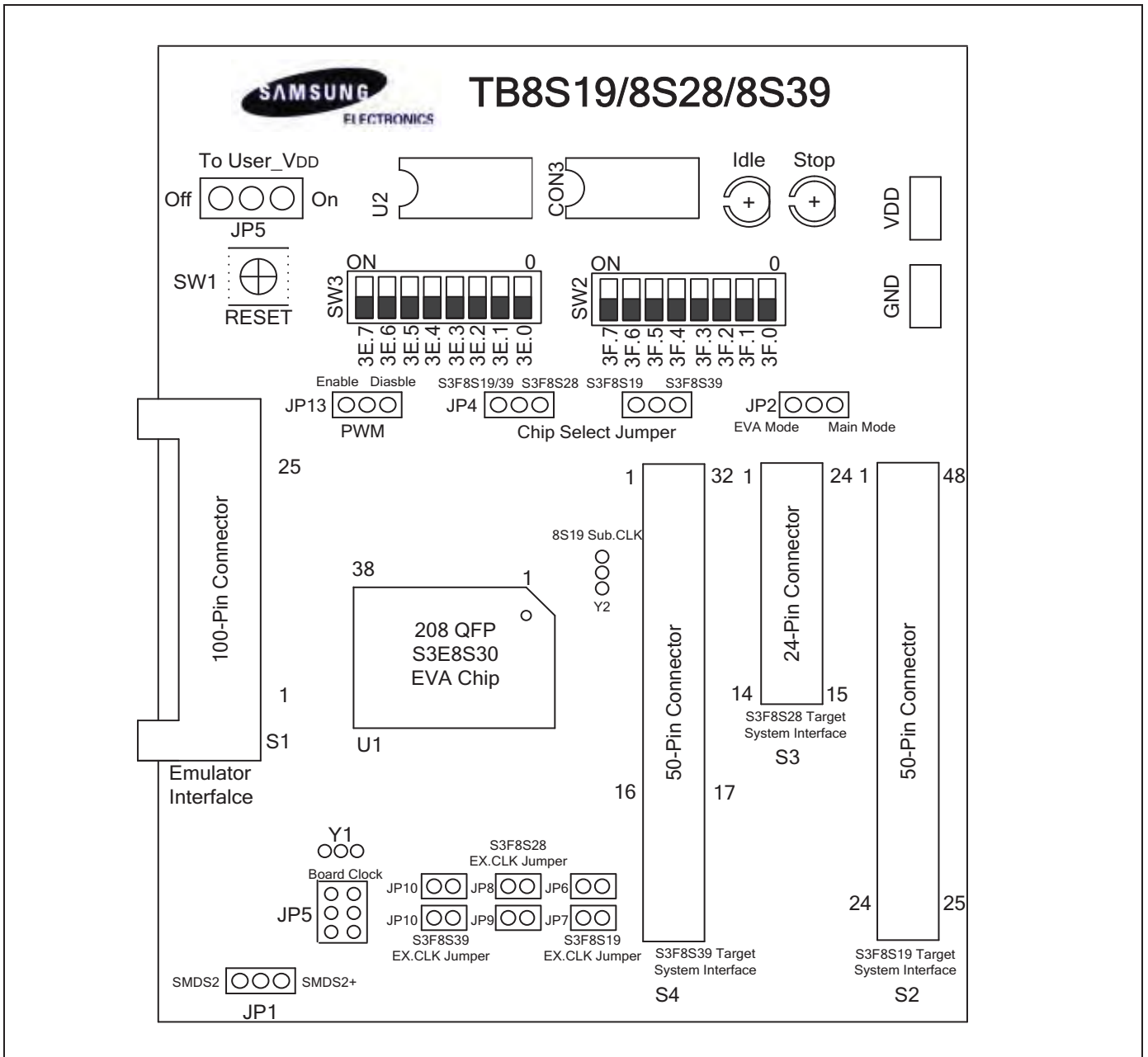


Figure 26-1 Development System Configuration

**26.1.2.1 TB8S19/8S28/8S39 Target Board**

The TB8S19/8S28/8S39 target board is used for the S3F8S19/F8S15/8S28/8S24/8S39 microcontrollers. The TB8S19/8S28/8S39 target board is operated as target CPU with Emulator (OPENIce I-500/2000, SK-1200).

*Figure 26-2* illustrates the TB8S19/8S28/8S39 target board configuration.



**Figure 26-2 TB8S19/8S28/8S39 Target Board Configuration**


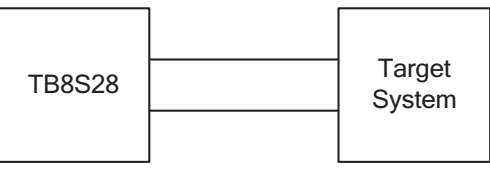


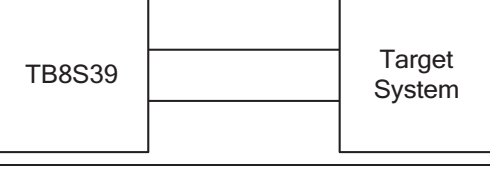


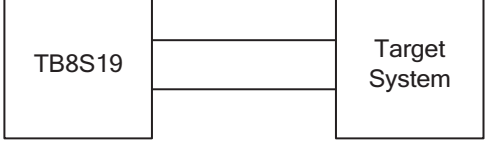
[Table 26-1](#) describes the UART 1 low byte control register.


**Table 26-1 UART 1 Low Byte Control Register (UART1CONL)**

| <b>Symbols</b> | <b>Usage</b>           | <b>Description</b>   |
|----------------|------------------------|--|
| JP3, JP4       | Device Selection       | Selection of device: S3F8S19/F8S15, S3F8S28, S3F8S39   |
| JP6, JP7       | Ex.CLK selection       | Set external clock connect to S3F8S19/F8S15 EVA-chip.  |
| JP12           | User's Power selection | Selection of Power to User.  |
| JP2            | MODE Selection         | Selection of Eva/Main-chip mode of S3F8S19/F8S15 EVA-chip                                      |
| JP1            | Emulator selection     | Selection of SMDS2/SMDS2+  |
| JP5            | Clock Source Selection | Selection of debug with internal/external clock  |
| SW2, SW3       | 8-pin switch           | Smart Option setting for S3F8S19/F8S15 EVA-chip  |
| S1             | 100-pin connector      | Connection between emulator and TB8S8S19 target board.   |
| S2             | 24-pin connector       | Connection between target board and user application system                                    |
| RESET          | Push button            | Generation low active reset signal to S3F8S19/F8S15 EVA-chip                                   |
| VCC, GND       | POWER connector        | External power connector for TB8S19/8S28/8S39  |
| IDLE, STOP LED | STOP/IDLE Display      | Indicate the status of STOP or IDLE of S3F8S19/F8S15 EVA-chip on TB8S19/8S28/8S39 target board |
| JP3            | PWM selection          | Selection of PWM enable/disable  |

[Table 26-2](#) describes the device selection settings for TB8S19/8S28/8S39.


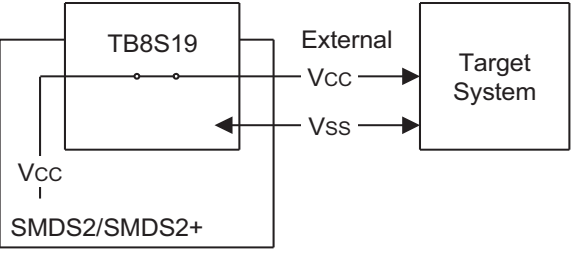

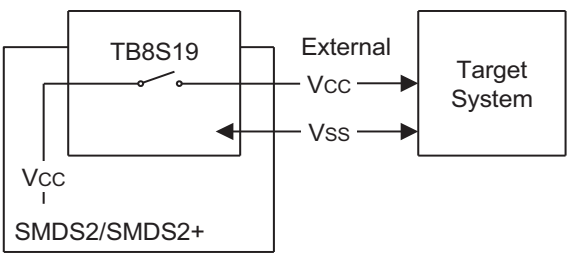
**Table 26-2 Device Selection Settings for TB8S19/8S28/8S39**

| "Device Selection" Settings   | Operating Mode   | Comments             |
|---|--|----------------------|
| Device Selection:JP4<br>8S19/39  8S28  |  | Operates with TB8S28 |
| Device Selection<br>JP4<br>8S19/8S39  8S28<br>JP3<br>8S19  8S39 |  | Operates with TB8S39 |
| Device Selection<br>JP4<br>8S19/39  8S28<br>JP3<br>8S19  8S39   |  | Operates with TB8S19 |

**NOTE:** The symbols in the "8S19" Setting column indicates the electrical short (off) configuration: 

[Table 26-3](#) describes the power selection settings for TB8S19/8S28/8S39.

**Table 26-3 Power Selection Settings for TB8S19/8S28/8S39**


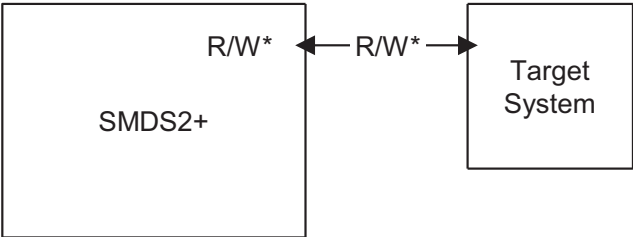
| "To User_Vcc" Settings  | Operating Mode   | Comments  |
|---|--|---|
| To user_VDD<br>off  on |  | The SMDS2/SMDS2+ main board supplies $V_{DD}$ to the target board (evaluation chip) and the target system.                                  |
| To user_VDD<br>off  on |  | The SMDS2/SMDS2+ main board supplies $V_{DD}$ only to the target board (evaluation chip). The target system must have its own power supply. |

### 26.1.2.2 SMDS2+ Selection (SAM8)

To write data into program memory that is available in SMDS2+, you should select the target board for SMDS2+ through a switch. Otherwise, the program memory writing function is not available.

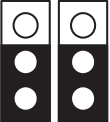



[Table 26-4](#) describes the SMDS2+ tool selection setting.

**Table 26-4 The SMDS2+ Tool Selection Setting**

| "JP4" Setting  | Operating Mode   |
|--|--|
| SMDS2  SMDS2+ |  |

[Table 26-5](#) describes using single header pins to select clock source/PWM/operation mode.

**Table 26-5 Using Single Header Pins to Select Clock Source/PWM/Operation Mode**

| Target Board Part  | Comments   |
|--|--|
| Board CLK<br><br>Inner CLK<br>JP5<br>Clock Source | Uses SMDS2/SMDS2+ internal clock source as the system clock.<br>Default Setting                  |
| Board CLK<br><br>Inner CLK<br>JP5<br>Clock Source | Uses external crystal or ceramic oscillator as the system clock.                                 |
| <br>JP6<br>JP7                                    | Connects Clock to S3F8S19/F8S15. (JP10-11, JP8-9 off)  |
| Main Mode<br><br>EVA Mode<br>JP2                  | The S3E8S30 runs in main mode, just same as S3F8S28/F8S24. The debug interface is not available. |



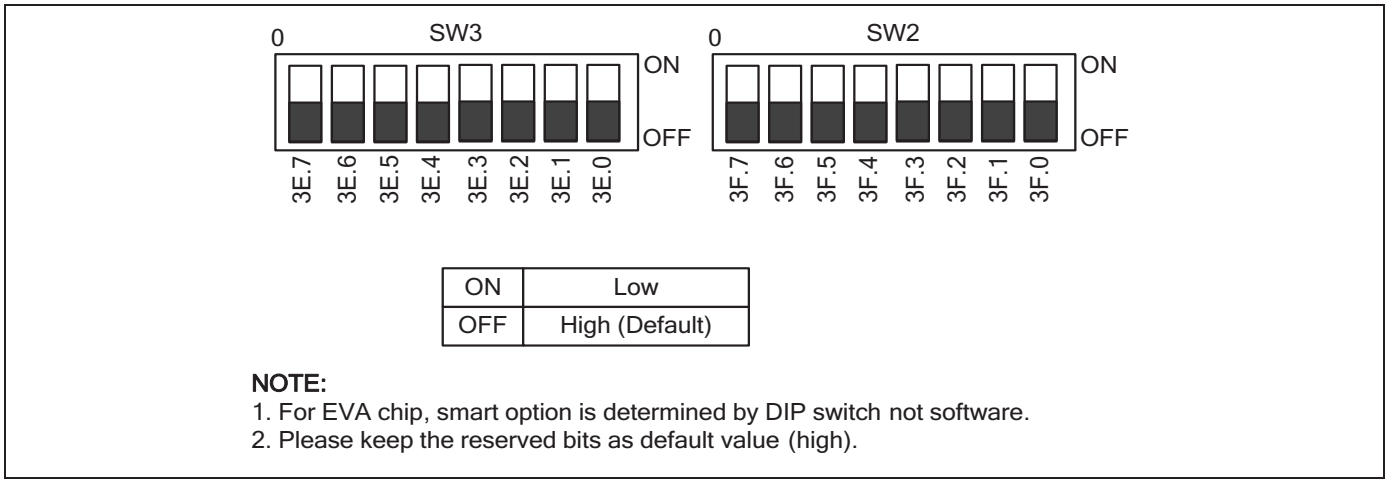
| Target Board Part                           | Comments  |
|---|---|
| <p>Main Mode</p> <p>JP2</p> <p>EVA Mode</p> | <p>The S3E8S30 runs in EVA mode, available. When debug program, set the jumper in this mode.</p> <p>Default Setting</p> |

Table 26-6 describes using single header pins as the input path for external trigger sources.

**Table 26-6 Using Single Header Pins as the Input Path for External Trigger Sources**

| Target Board Part  | Comments   |
|--|--|
| <p>External Triggers</p> <p>Ch1(TP3)</p> <p>Ch2(TP4)</p> | <p>Connector from External Trigger Sources of the Application System</p> <p>You can connect an external trigger source to one of the two external trigger channels (CH1 or CH2) for the SK-1000/SMDS2+ breakpoint and trace functions.</p> |

Figure 26-3 illustrates the DIP switch for smart option.



**Figure 26-3 DIP Switch for Smart Option**

- IDLE LED  
This LED is ON when the evaluation chip (S3E8S30) is in idle mode.
- STOP LED  
This LED is ON when the evaluation chip (S3E8S30) is in stop mode.

Figure 26-4 illustrates the 48-pin connector for TB8S19/8S28/8S39.

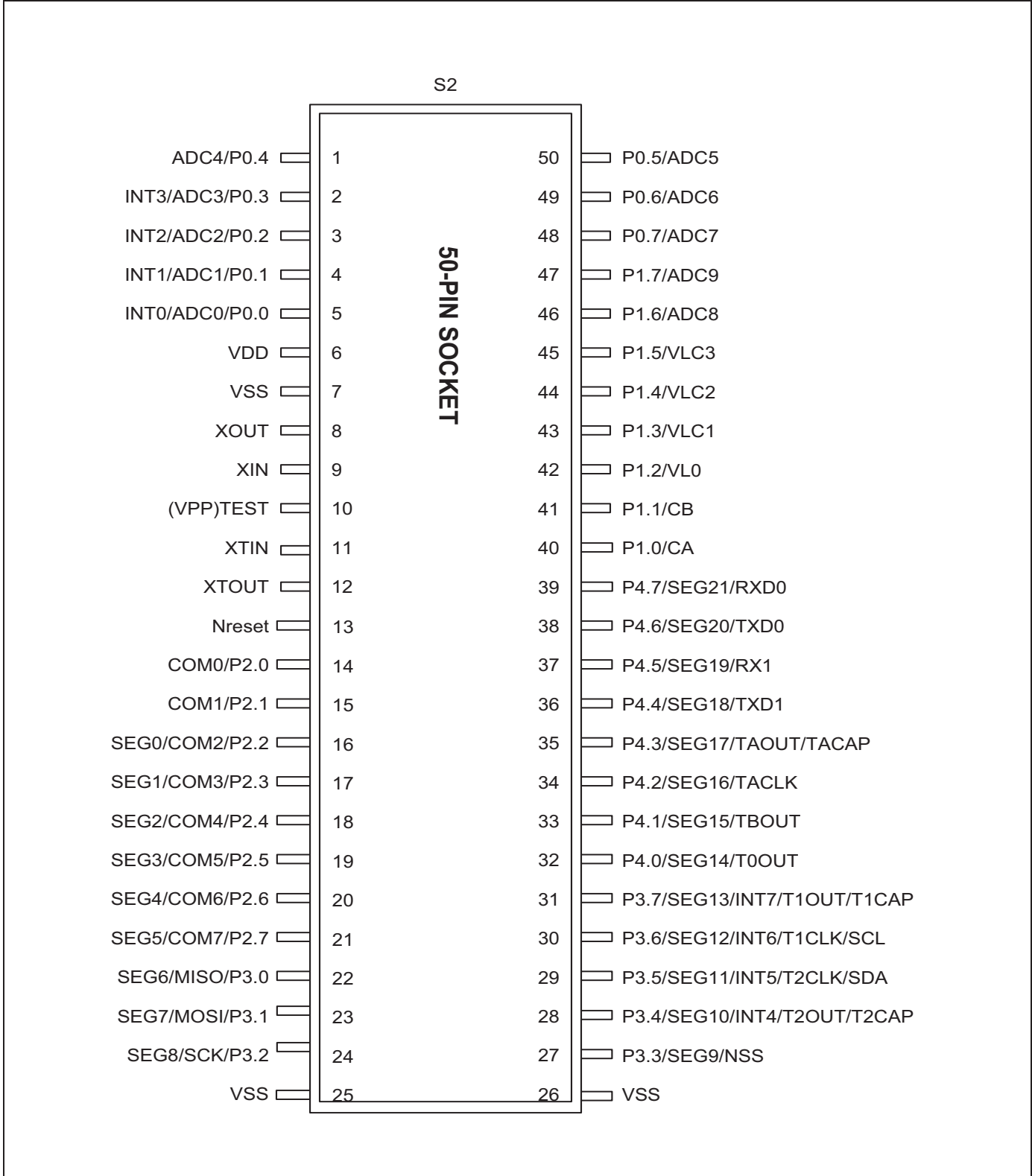


Figure 26-4 48-Pin Connector for TB8S19/8S28/8S39

Figure 26-5 illustrates the S3F8S19/F8S15 probe adapter for 48 pin package.

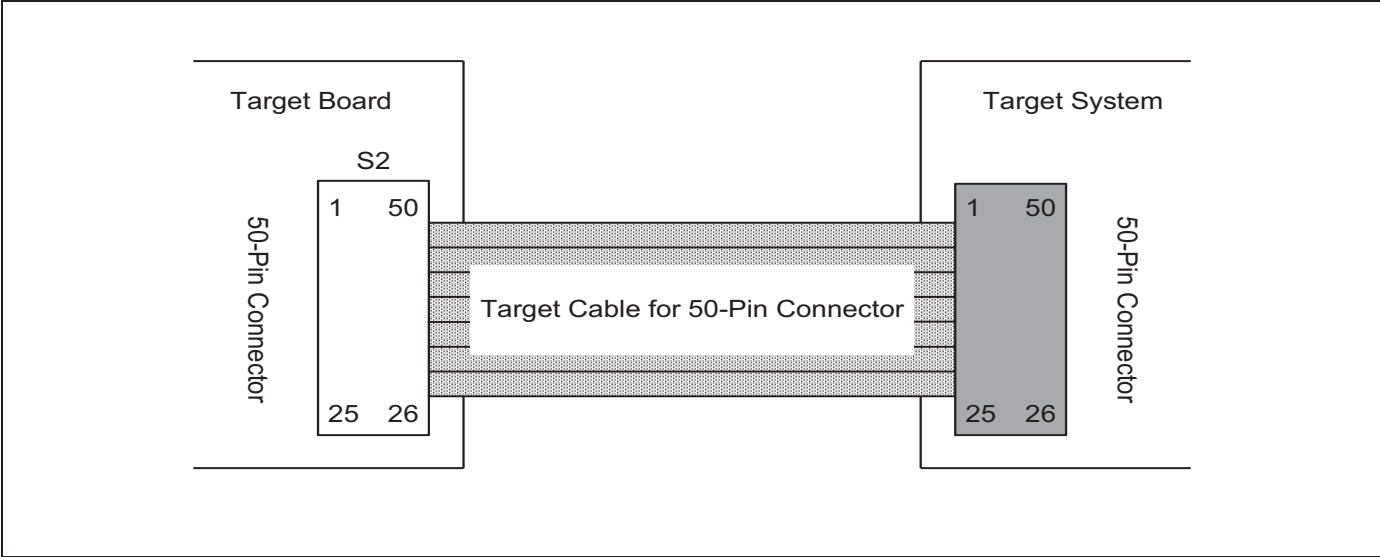


Figure 26-5 S3F8S19/F8S15 Probe Adapter for 48 Pin Package

## **26.2 Third Parties for Development Tools**

SAMSUNG provides a complete line of development tools for microcontroller of SAMSUNG. With long experience in developing MCU systems, our third parties are leading companies in the technology of tools. SAMSUNG In-circuit emulator solution covers a wide range of capabilities and prices, from a low cost ICE to a complete system with an OTP/MTP programmer.

### **26.2.1 In-Circuit Emulator for SAM8 family**

- OPENice-i500/2000
- SmartKit SK-1200

### **26.2.2 OTP/MTP Programmer**

- SPW-uni
- GW-uni (8-gang programmer)
- AS-pro



### **26.2.3 Development Tools Suppliers**


You can contact our local sales offices or the 3<sup>rd</sup> party tool suppliers directly for getting development tools as described in sub section 1.2.4.8.

26.2.4 8-Bit In-Circuit Emulator

|   |   |
|---|---|
| <p style="text-align: center;"><b>OPENice - i500</b></p>   | <p><b>AIJI System</b></p> <ul style="list-style-type: none"> <li>• TEL: 82-31-223-6611</li> <li>• FAX: 82-331-223-6613</li> <li>• E-mail: <a href="mailto:openice@aijisystem.com">openice@aijisystem.com</a><br/> <a href="mailto:stroh@yicsystem.com">stroh@yicsystem.com</a></li> <li>• URL: <a href="http://www.aijisystem.com">http://www.aijisystem.com</a></li> </ul> |
| <p style="text-align: center;"><b>OPENice - i2000</b></p>  | <p><b>AIJI System</b></p> <ul style="list-style-type: none"> <li>• TEL: 82-31-223-6611</li> <li>• FAX: 82-331-223-6613</li> <li>• E-mail: <a href="mailto:openice@aijisystem.com">openice@aijisystem.com</a><br/> <a href="mailto:stroh@yicsystem.com">stroh@yicsystem.com</a></li> <li>• URL: <a href="http://www.aijisystem.com">http://www.aijisystem.com</a></li> </ul> |
| <p style="text-align: center;"><b>SK-1200</b></p>         | <p><b>Seminix</b></p> <ul style="list-style-type: none"> <li>• TEL: 82-2-539-7891</li> <li>• FAX: 82-2-539-7819</li> <li>• E-mail: <a href="mailto:sales@seminix.com">sales@seminix.com</a></li> <li>• URL: <a href="http://www.seminix.com">http://www.seminix.com</a></li> </ul>  |

26.2.5 OTP/MTP Programmer (Writer)

|   |   |   |
|---|---|---|
|    | <p><b>SPW-uni</b><br/><b>Single OTP/MTP/FLASH Programmer</b></p> <ul style="list-style-type: none"> <li>• Download/Upload and data edit function</li> <li>• PC-based operation with USB port</li> <li>• Full function regarding OTP/MTP/FLASH MCU programmer (Read, Program, Verify, Blank, Protection ...)</li> <li>• Fast programming speed (4 Kbyte/sec)</li> <li>• Support all of SAMSUNG OTP/MTP/FLASH MCU devices</li> <li>• Low-cost</li> <li>• NOR Flash memory (SST, Samsung and so on)</li> <li>• NAND Flash memory (SLC)</li> <li>• Supports new devices by adding device files or by upgrading the software.</li> </ul>   | <p><b>SEMINIX</b></p> <ul style="list-style-type: none"> <li>• TEL: 82-2-539-7891</li> <li>• FAX: 82-2-539-7819.</li> <li>• E-mail: <a href="mailto:sales@seminix.com">sales@seminix.com</a></li> <li>• URL: <a href="http://www.seminix.com">http://www.seminix.com</a></li> </ul> |
|  | <p><b>GW-uni</b><br/><b>Gang Programmer for OTP/MTP/FLASH MCU</b></p> <ul style="list-style-type: none"> <li>• 8 devices programming at one time</li> <li>• Fast programming speed :OTP (2 Kbps)/MTP (10 Kbps)</li> <li>• Maximum buffer memory:100Mbyte</li> <li>• Operation mode: PC base/Stand-alone(no PC)</li> <li>• Supports full functions of OTP/MTP (Read, Program, Checksum, Verify, Erase, Read protection, Smart option)</li> <li>• Simple GUI(Graphical User Interface)</li> <li>• Device information setting by a device part no.</li> <li>• LCD display and touch key (Stand-alone mode operation)</li> <li>• System upgradable (Simple firmware upgrade by user)</li> </ul> | <p><b>SEMINIX</b></p> <ul style="list-style-type: none"> <li>• TEL: 82-2-539-7891</li> <li>• FAX: 82-2-539-7819.</li> <li>• E-mail: <a href="mailto:sales@seminix.com">sales@seminix.com</a></li> <li>• URL: <a href="http://www.seminix.com">http://www.seminix.com</a></li> </ul> |

|   |   |   |
|---|---|---|
|  | <p><b>AS-pro</b><br/><b>On-board programmer for Samsung Flash MCU</b></p> <ul style="list-style-type: none"> <li>• Portable and stand alone Samsung OTP/MTP/FLASH Programmer for After Service</li> <li>• Small size and light weight for the portable use</li> <li>• Supports all of SAMSUNG OTP/MTP/FLASH devices</li> <li>• HEX file download through USB port from PC</li> <li>• Very fast program and verify time (OTP: 2 Kbytes per second, MTP:10Kbytes per second)</li> <li>• Internal large buffer memory (118M Bytes)</li> <li>• Driver software run under various Operating Systems (O/S) (Windows 95/98/2000/XP)</li> <li>• Full function regarding OTP/MTP programmer (Read, Program, Verify, Blank, Protection and so on)</li> <li>• Two types of power supplies (User system power or USB power adapter)</li> <li>• Supports firmware upgrade</li> </ul> | <p><b>SEMINIX</b></p> <ul style="list-style-type: none"> <li>• TEL: 82-2-539-7891</li> <li>• FAX: 82-2-539-7819.</li> <li>• E-mail: <a href="mailto:sales@seminix.com">sales@seminix.com</a></li> <li>• URL: <a href="http://www.seminix.com">http://www.seminix.com</a></li> </ul>               |
|   | <p><b>Flash writing adapter board</b></p> <ul style="list-style-type: none"> <li>• Special flash writing socket for S3F8S28/F8S24 – 24SOP, 24TSSOP, 20DIP, 20SOP, 20SSOP</li> </ul>   | <p><b>C&amp;A technology</b></p> <ul style="list-style-type: none"> <li>• TEL: 82-2-2612-9027</li> <li>• FAX: 82-2-2612-9044</li> <li>• E-mail: <a href="mailto:wisdom@cnatech.com">wisdom@cnatech.com</a></li> <li>• URL: <a href="http://www.cnatech.com">http://www.cnatech.com</a></li> </ul> |