

THICK FILM (FOR HIGH VOLTAGE)

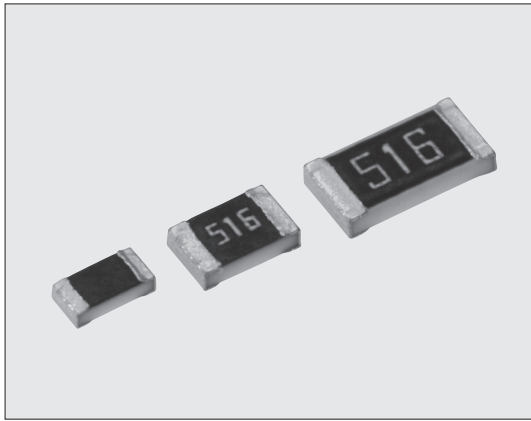

HV73V 高压用片式电阻器 (汽车用) Flat Chip Resistors For High Voltage (For Automotive)

矩形片式电阻器
Flat Chip Resistors



■ 结构图 Construction

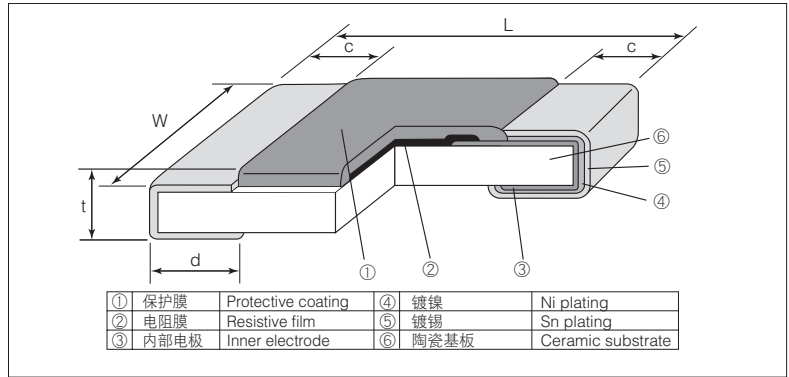

外观颜色：黑色 Coating color：Black

■ 特点 Features

- 与通用型片状电阻器 (RK73) 相比，对最高使用电压进行了高耐压化。
- 对应回流焊、波峰焊。
- 符合欧盟RoHS。电极、电阻膜层、玻璃中所含的铅玻璃不适用欧盟RoHS指令。
- 最适合于汽车等需要高可靠性的用途。AEC-Q200相关数据已取得。
- Superior to RK73 series in maximum working voltage.
- Suitable for flow and reflow solderings.
- Products meet EU-RoHS requirements. EU-RoHS regulation is not intended for Pb-glass contained in electrode, resistor element and glass.
- Suitable for high reliable applications like automotives. AEC-Q200 qualified.

■ 用途 Applications

- 车载变频器、DC-DC转换器、蓄电池管理、车载充电器、HID灯
- Inverter, DC-DC converter, Battery Management, Charger, HID lamp

■ 参考标准 Reference Standards

IEC 60115-8
JIS C 5201-8
EIAJ RC-2134C

■ 外形尺寸 Dimensions

型号 Type (Inch Size Code)	尺寸 Dimensions (mm)					Weight (g) (1000pcs)
	L±0.2	W	c	d	t±0.1	
1J (0603)	1.6	0.8±0.1	0.3±0.1	0.3±0.1	0.45	2.14
2A (0805)	2.0	1.25±0.1	0.4±0.2	0.3±0.1	0.5	4.54
2B (1206)	3.2	1.6±0.2	0.5±0.3	0.4±0.2	0.6	9.14

■ 品名构成 Type Designation

实例 Example

品种 Product Code	额定功率 Power Rating	端子表面材质 Terminal Surface Material	二次加工 Taping	公称电阻值 Nominal Resistance	阻值允许偏差 Resistance Tolerance
HV73V	1J:0.1W 2A:0.25W 2B:0.25W	T: Sn	TD:4mm pitch punch paper BK: Bulk	D,F: 4 digits G,J: 3 digits	D: ±0.5% F: ±1% G: ±2% J: ±5%

欲知关于此产品含有的环境负荷物质详情 (除EU-RoHS以外)，请与我们联系。
编带细节请参考卷末附录C。

Contact us when you have control request for environmental hazardous material other than the substance specified by EU-RoHS.

For further information on taping, please refer to APPENDIX C on the back pages.

■ 额定值 Ratings

型号 Type	额定功率 Power Rating	额定值 环境温度 Rated Ambient Temp.	额定值 端子部温度 Rated Terminal Part Temp.	电阻温度系数 T.C.R. (×10 ⁻⁶ /K)	电阻值范围 Resistance Range (Ω)				最高使用电压 Max. Working Voltage	最高 过载电压*1 Max. Overload Voltage (D.C.)	编带和包装数/卷 Taping & Qty/Reel (pcs)
					D: ±0.5% E24, E96	F: ±1% E24, E96	G: ±2% E24	J: ±5% E24			
HV73V1J	0.1W	70℃	80℃	±100*2	—	10k~10M	10k~10M	10k~10M	350V	500V	5,000
HV73V2A	0.25W			±100	100k~1M	100k~10M	100k~10M	100k~10M	400V	800V	
HV73V2B	0.25W			±200	—	—	—	11M~51M	800V	1000V	
				±100	100k~1M	100k~10M	100k~10M	100k~10M			
				±200	—	—	—	11M~51M			

使用温度范围 Operating Temperature Range: -55℃~+155℃

额定电压是√额定功率×公称电阻值所算出的值或表中最高使用电压两者中小的值为额定电压。

Rated voltage = √Power Rating × Resistance value or Max. working voltage, whichever is lower.

*1 最高过载电压为直流电压。 *1 Max. overload voltage is specified by D.C. voltage.

*2 1.02MΩ~10MΩ的冷T.C.R. (-55℃~+25℃) 为±200×10⁻⁶/K。 *2 Cold T.C.R. (-55℃~+25℃) of 1.02MΩ~10MΩ is ±200×10⁻⁶/K.

根据客户的使用状况，如果不清楚是该使用额定环境温度还是额定端子部温度，请以额定端子部温度为优先。

详情请参照14~17页的“端子部温度负荷特性曲线的说明”。

If any questions arise whether to use the “Rated Ambient Temperature” or the “Rated Terminal Part Temperature” in your usage conditions, please give priority to the “Rated Terminal Part Temperature”.

For more details, please refer to “Introduction of the derating curves based on the terminal part temperature” in page 14 to 17.

■ 负荷减轻特性曲线 Derating Curve

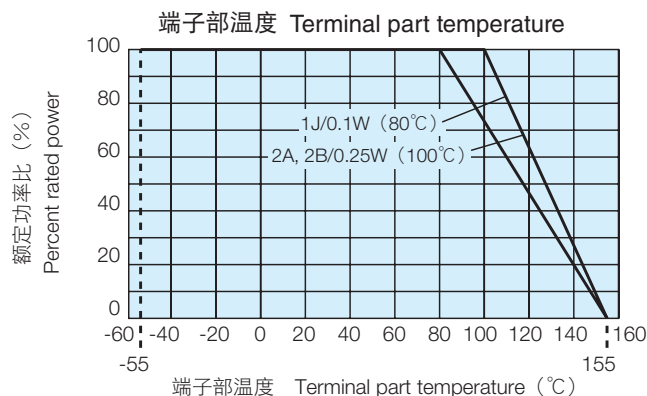
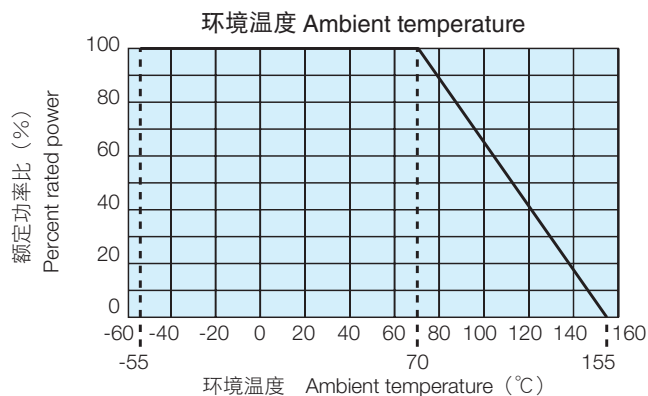

在环境温度70℃以上使用时，应按照上图负荷减轻特性曲线，减小额定功率。
For resistors operated at an ambient temperature of 70℃ or above, a power rating shall be derated in accordance with the above derating curve.

超过上述端子部温度使用时，请根据负荷减轻特性曲线减小额定功率后使用。
※关于使用方法，请参照卷首的“端子部温度负荷减轻特性曲线的说明”。
For resistors operated terminal part temperature of described for each size or above, a power rating shall be derated in accordance with derating curve.
※Please refer to “Introduction of the derating curves based on the terminal part temperature” on the beginning of our catalog before use.

■ 性能 Performance

试验项目 Test Items	标准值 Performance Requirements $\Delta R \pm (\%+0.1\Omega)$		试验方法 Test Methods
	保证值 Limit	代表值 Typical	
电阻值 Resistance	在规定的允许偏差内 Within specified tolerance	—	25℃
电阻温度系数 T.C.R.	在规定值以内 Within specified T.C.R.	—	+25℃/-55℃ and +25℃/+125℃
过载(短时间) Overload (Short time)	2	0.5	额定电压(D.C.)×2.5倍施加5秒钟 Rated voltage (D.C.)×2.5 for 5s
耐焊接热 Resistance to soldering heat	1	0.5	260℃±5℃, 10s±1s
温度突变 Rapid change of temperature	0.5: (10kΩ<R≤10MΩ) 1: (11MΩ≤R≤51MΩ)	0.3: (10kΩ≤R≤10MΩ) 0.5: (11MΩ≤R≤51MΩ)	-55℃ (30min.) / +125℃ (30min.) 100 cycles
耐湿负荷 Moisture resistance	2	0.75	40℃±2℃, 90%~95%RH, 1000h 1.5小时ON、0.5小时OFF的周期 1.5h ON/0.5h OFF cycle
在70℃时的耐久性 Endurance at 70℃	2	0.75	70℃±2℃, 1000h 1.5小时ON、0.5小时OFF的周期 1.5h ON/0.5h OFF cycle
高温放置 High temperature exposure	2	0.3	+155℃, 1000h

■ 使用注意事项 Precautions for Use

- 最高过载电压为直流电压，交流电压时，峰值电压请不要超过最高过载电压的电压。
- 片状电阻器的基材是氧化铝。由于和安装基板的热膨胀系数不同，在反复加热循环等热应力时，接合部的焊锡（焊脚部）有时会发生龟裂。如果环境温度反复发生很大的变动，并且载荷反复进行ON/OFF，则需要注意龟裂的发生。因热应力而发生的龟裂，取决于所安装的焊盘的大小、焊锡量、安装基板的散热性等，因此在环境温度有很大的变化或载荷ON/OFF的条件下使用时，请充分注意以进行设计。
- Max. overload voltage is specified by D.C. voltage. When using in A.C. voltage, the peak value of A.C. voltage shall not exceed the Maximum overload voltage.
- The substrate of chip resistors is alumina. Cracks may occur at the connection of solder (solder fillet portion) due to the difference of the coefficient of thermal expansion from a mounting board when heat stress like heat cycle, etc. are repeatedly given to them. Care should be taken to the occurrence of the cracks when the change in ambient temperature or ON/OFF of load is repeated. The occurrence of the crack by heat stress may be influenced by the size of a pad, solder volume, heat radiation of mounting board etc., so please pay careful attention to designing when a big change in ambient temperature and conditions for use like ON/OFF of load can be assumed.