

XKB SWITCH CONNECTOR

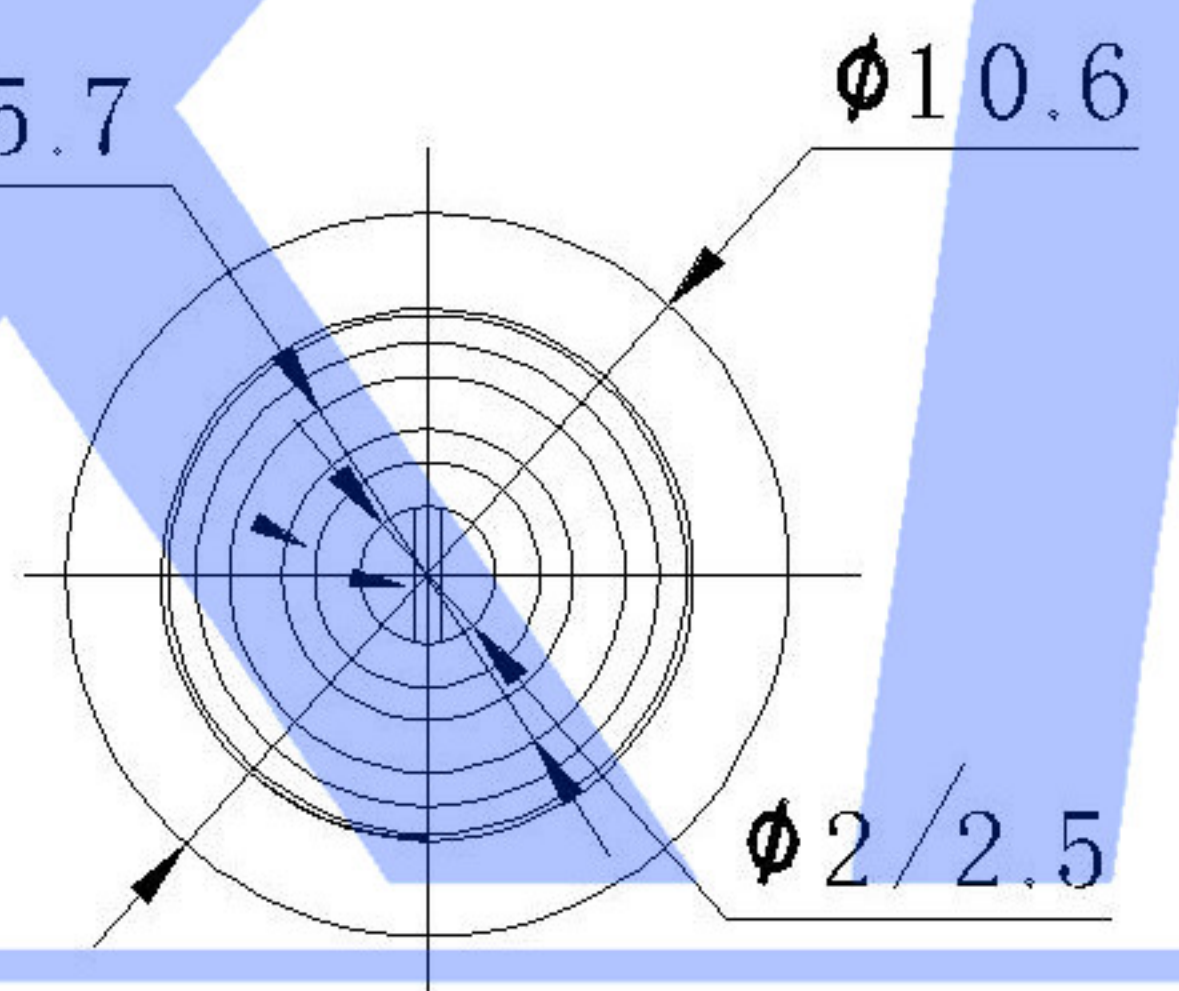

	MATERIAL	PLATING
center pin	brass	nickel
terminal 1	brass	silver
terminal 2	phosphor bronze	silver
terminal 3	brass	silver
bushing	brass	nickel
nut	brass	nickel
washer	steel	nickel
insulator	red vulcanized fiber	
plastic	PBT	

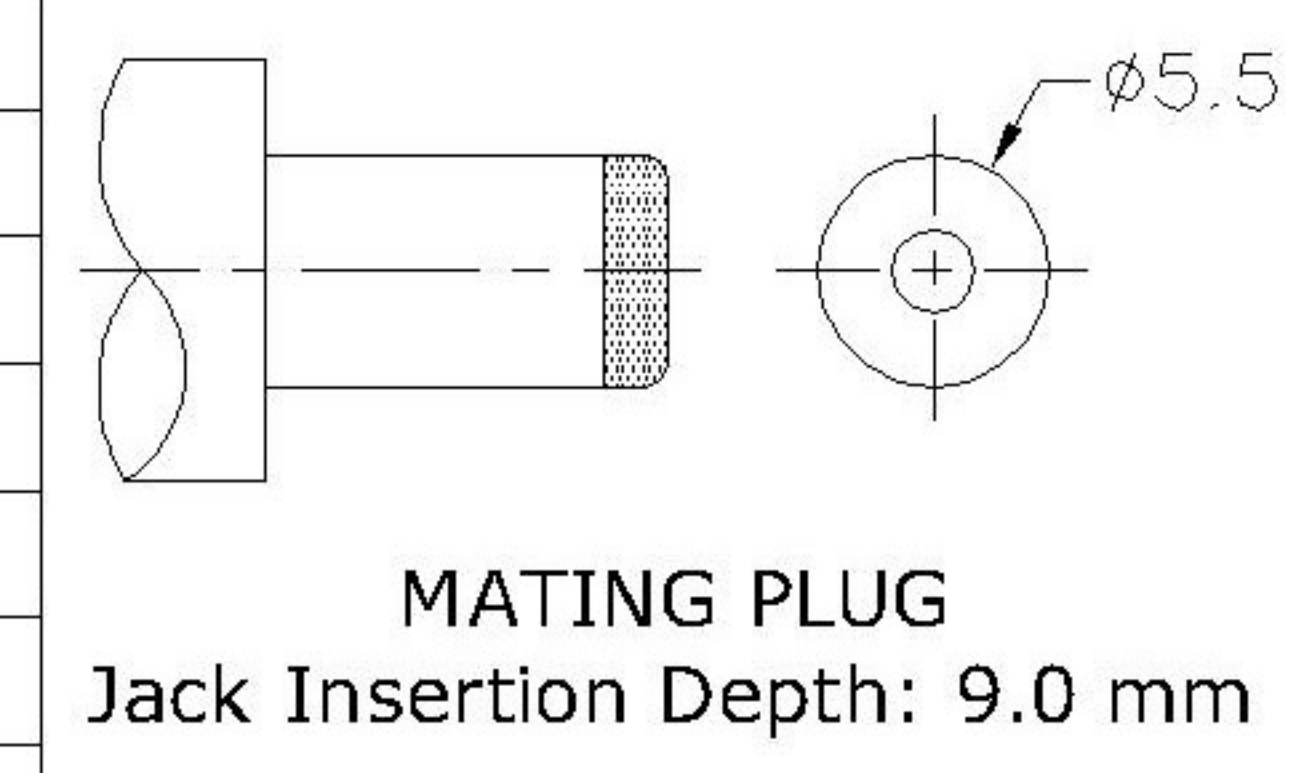

SCHEMATIC	
Model	DC-025
Center Pin	Ø2.0 mm
	Ø2.5 mm

△ X	DESCRIPTION	DATE	REVISED	APPROVED	ANGULAR	±ε
△ X					L ≤ 4	±L/2
△ X					4 < L ≤ 16	±0.1
MAPK					16 < L ≤ 63	±0.4
					L > 63	±0.5

DSND		DATE		SCALE: N/A	MODEL T/FE:
DWN		DATE		VIEW:	DC POWER JACK
CHKD		DATE		UNIT: mm	FART NO.:
APPD		DATE		SIZE: A4	DWG NO.:
XKB INDUSTRIAL PRECISION CO., LIMITED					DC-025-5A-2.0
	WEIGHT	SHEET	REVISION		
	1.0g	1/1	A0		