

1 2 3 4 5 6 7 8

A B C D E F

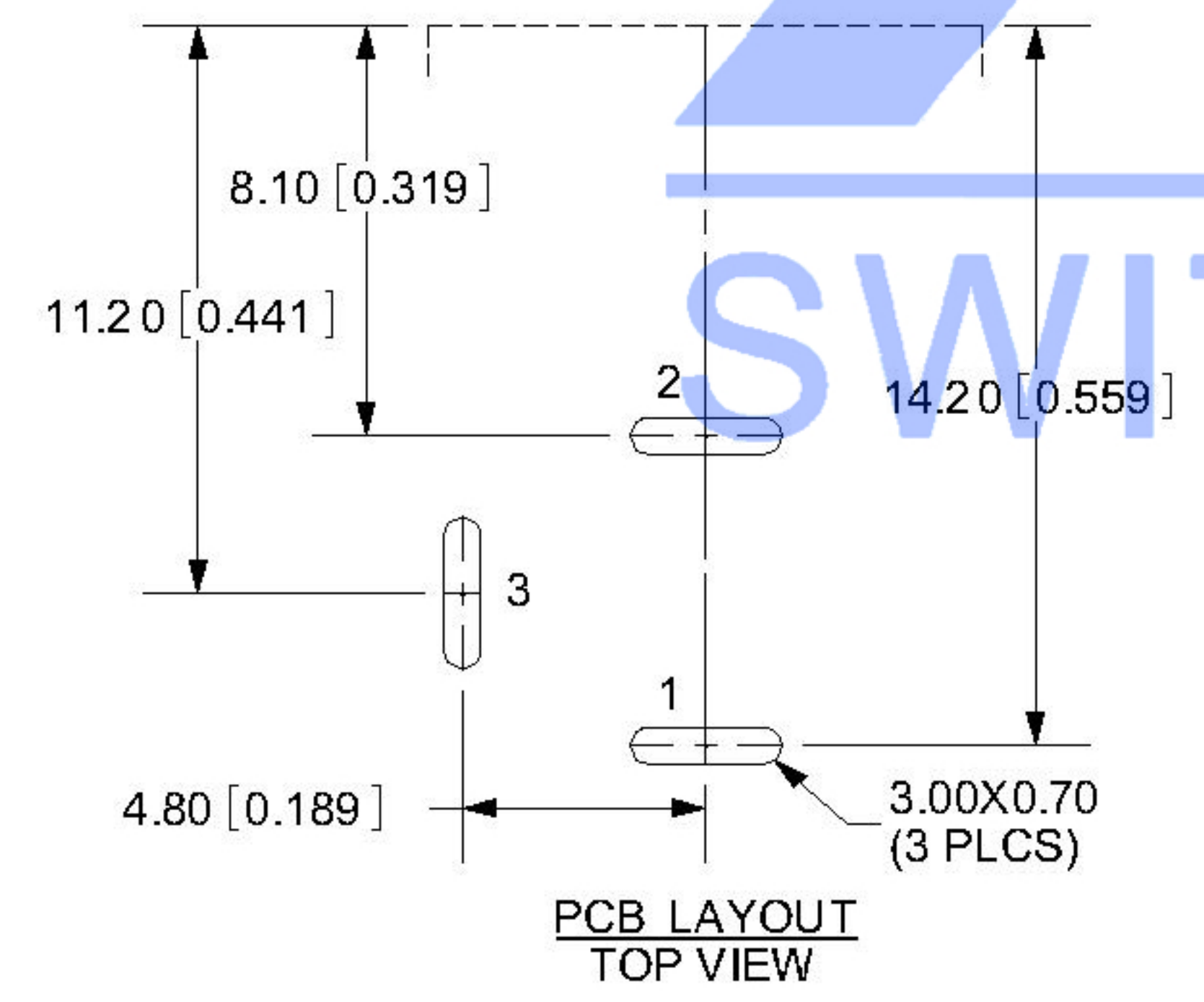
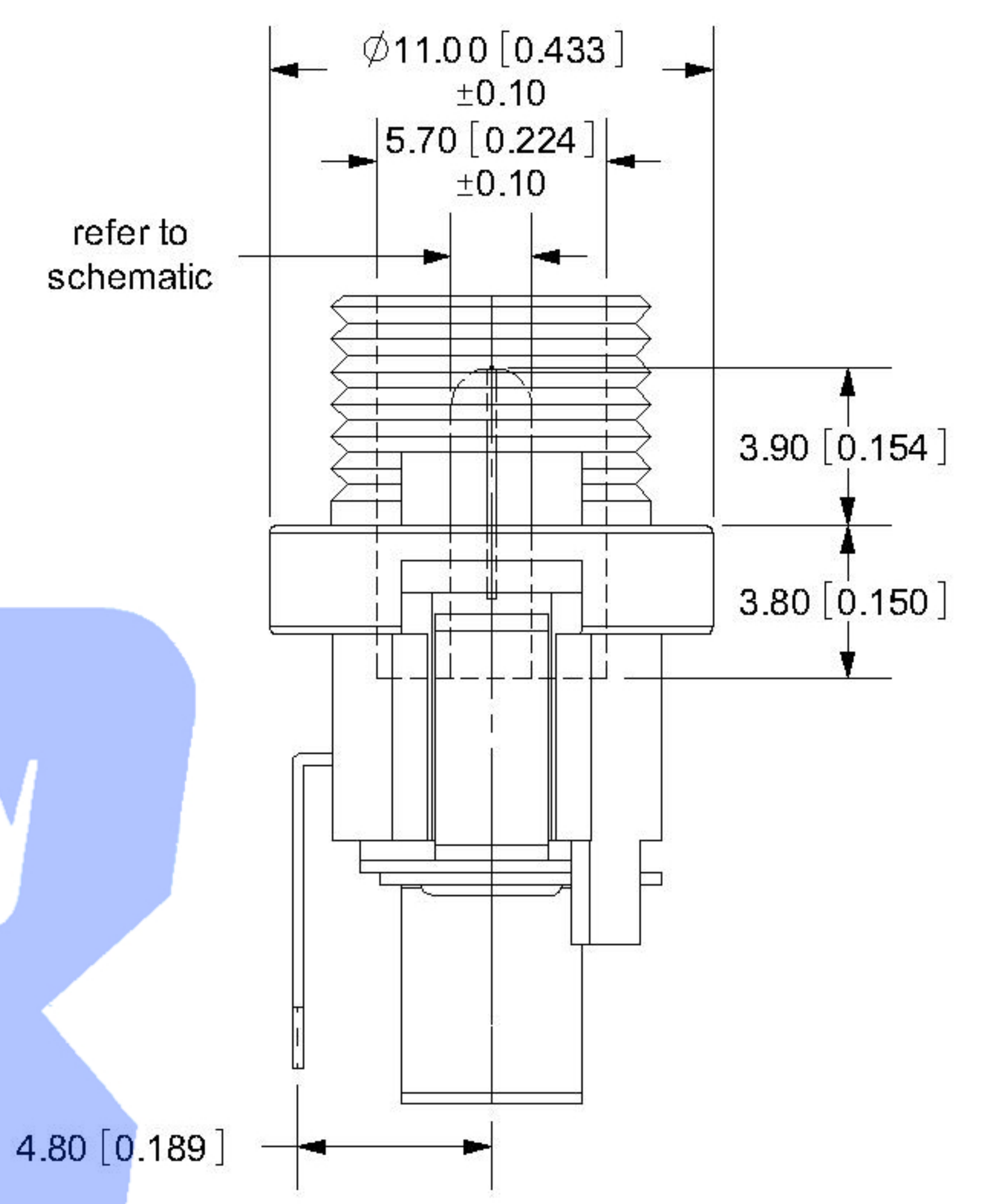
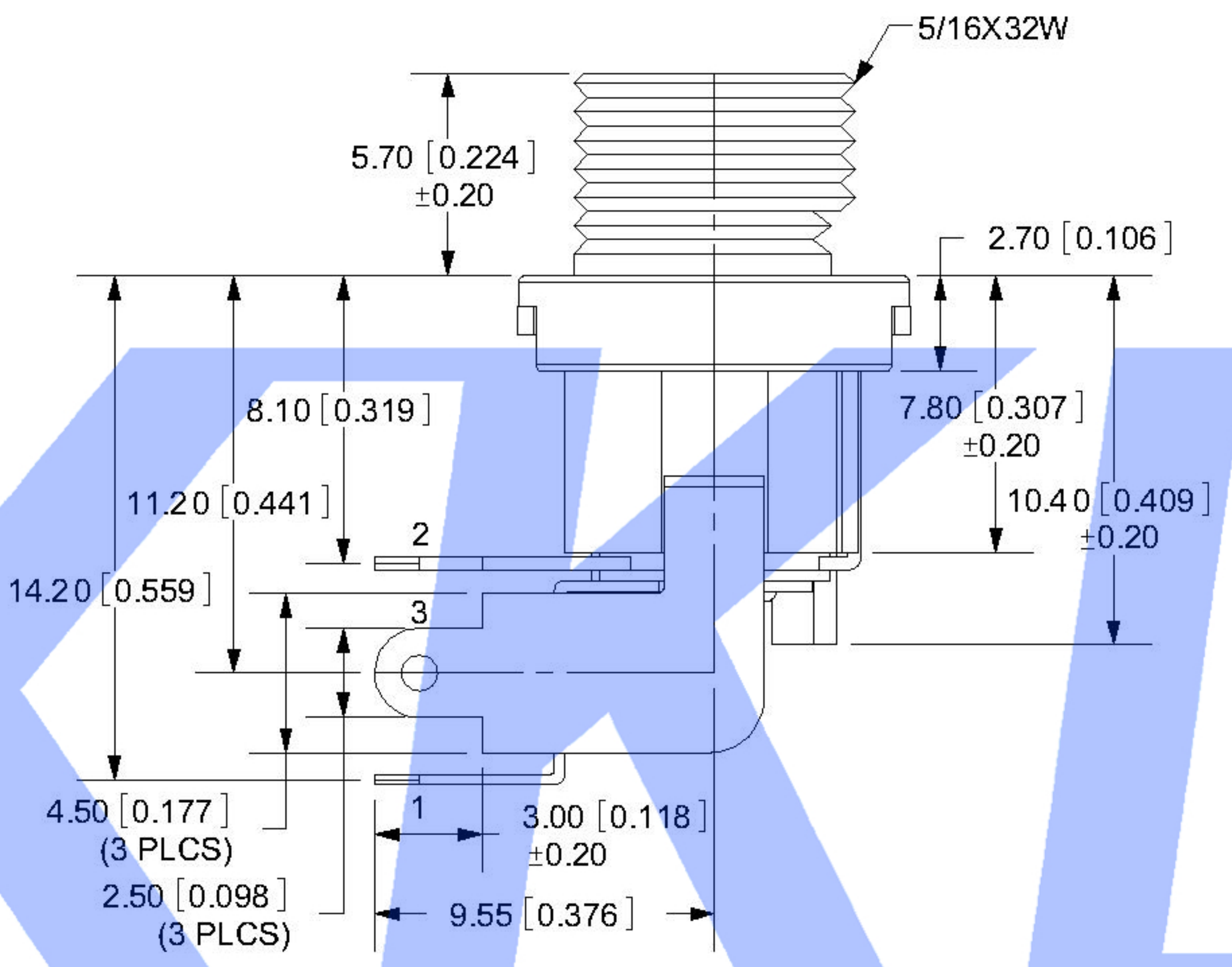
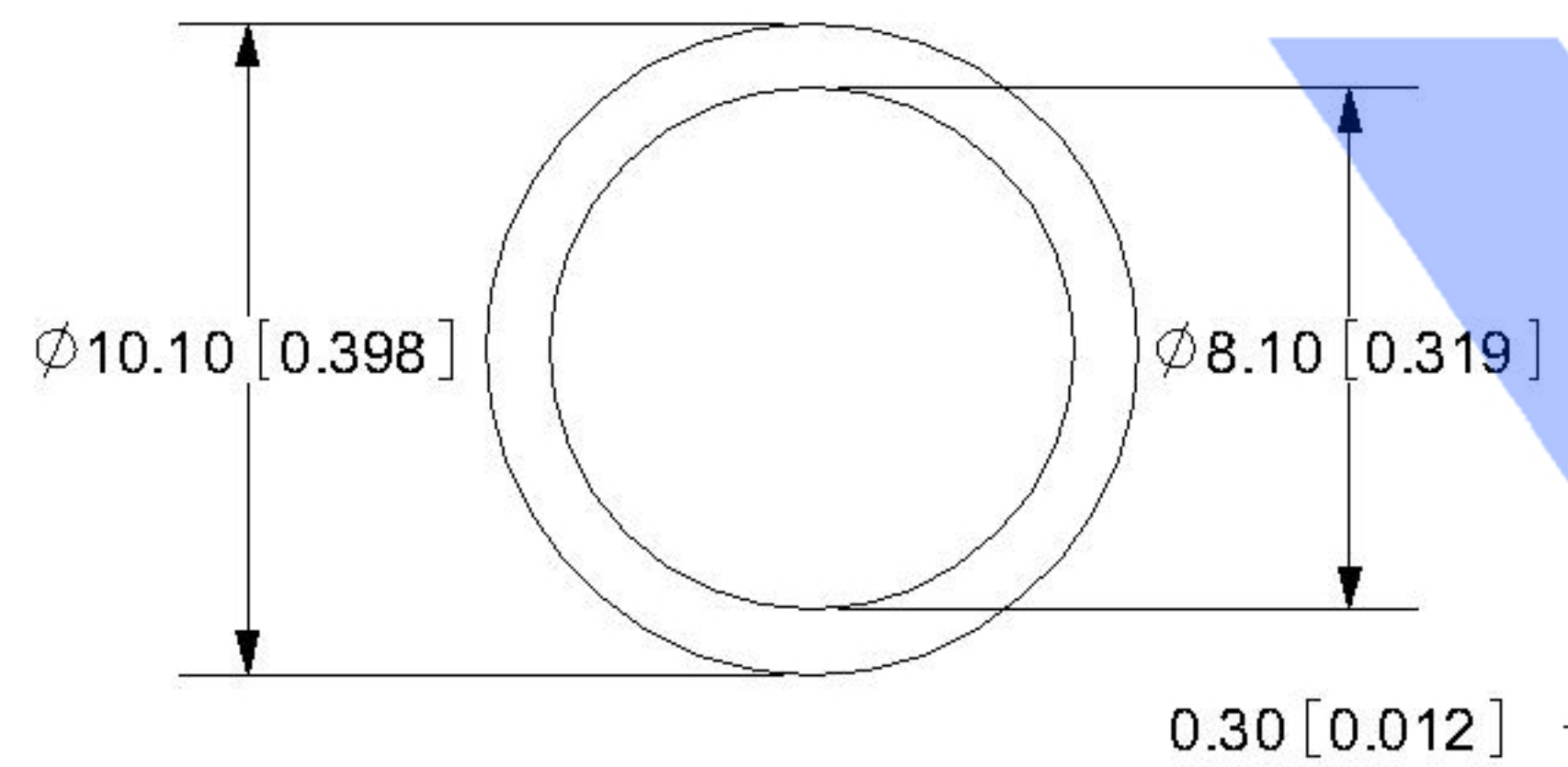
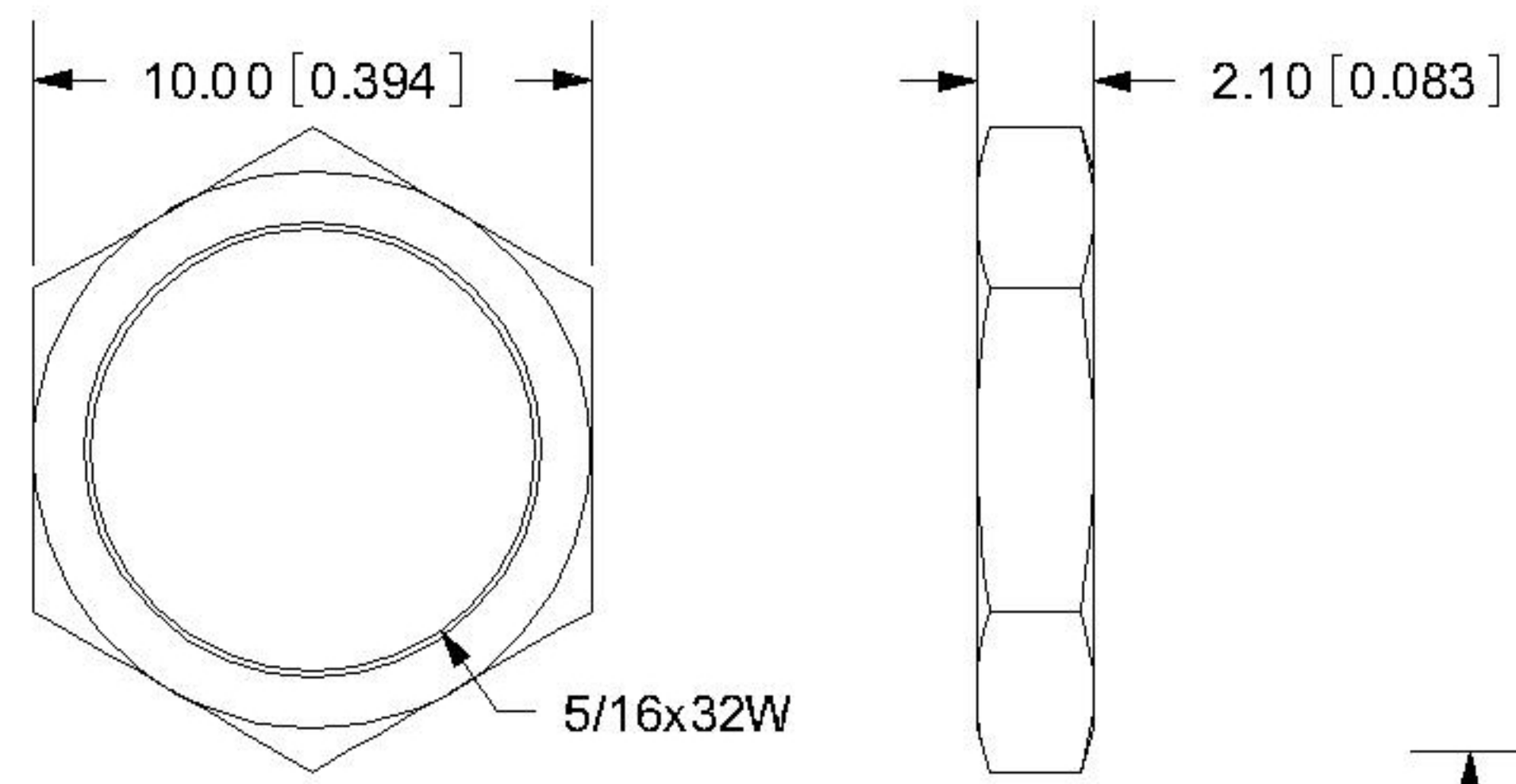

XKB

# SWITCH CONNECTOR

	MATERIAL	PLATING
center pin	brass	nickel
terminal 1	brass	silver
terminal 2	phosphor bronze	silver
terminal 3	brass	silver
bushing	brass	nickel
insulator	red vulcanite fiber	
plastic	PBT	
nut	brass	nickel
washer	steel	nickel

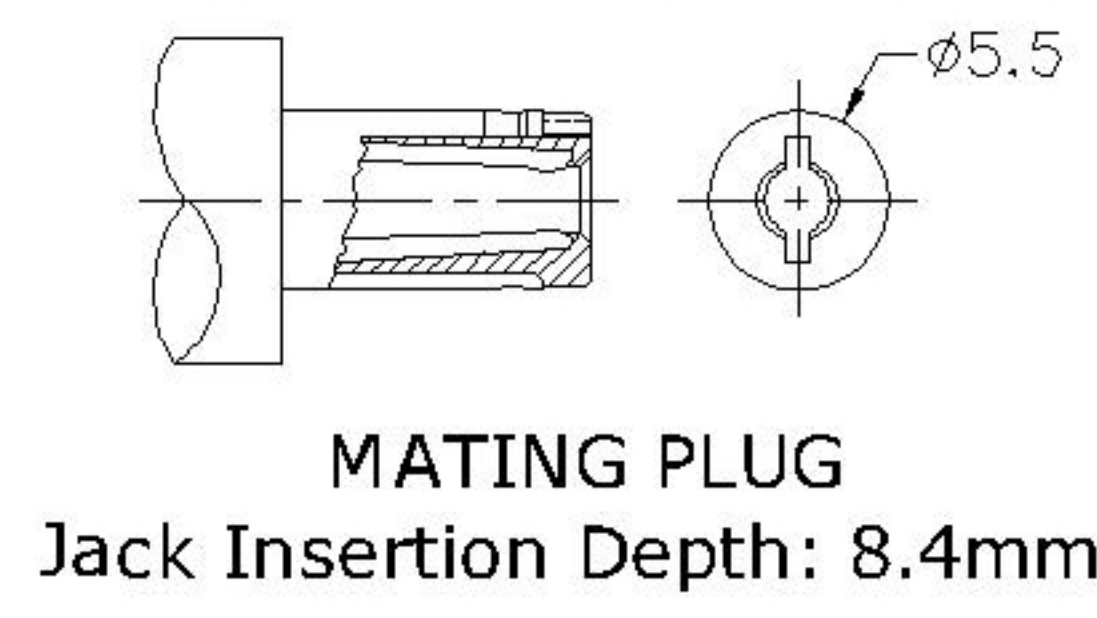

Schematic	
Model	Center Pin
DC-025LM	ø2.0 mm
DC-025LM	ø2.5 mm

MARK	DESCRIPTION	DATE	REVISED	APPROVED	UNSPECIFIED TOLERANCES
△ X					ANGULAR ± 5°
△ X					L ≤ 4 ± 0.2
△ X					4 < L ≤ 16 ± 0.3
					16 < L ≤ 63 ± 0.4
					L > 63 ± 0.5

DSND	DATE	SCALE: N/A	MODEL TYPE:
DWN	DATE	VIEW:	DC POWER JACK
CHKD	DATE	UNIT: mm	PART NO.:
APPD	DATE	SIZE: A4	DWG NO.:
<b>XKB INDUSTRIAL PRECISION CO., LIMITED</b>			DC-025LM-5A-2.0
WEIGHT	SHEET	REVISION	
1.0g	1/1	A0	

1 2 3 4 5 6 7 8