

Product Summary

$V_{(BR)DSS}$	$R_{DS(on)MAX}$	I_D
150V	6.2mΩ@10V	140A

Feature

- High density cell design for ultra low Rdson
- Fully characterized avalanche voltage and current
- Good stability and uniformity with high E_{AS}
- Excellent package for good heat dissipation

Application

- DC/DC Converter
- Ideal for high-frequency switching and synchronous rectification

Package

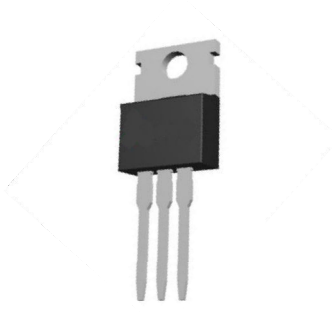

TO-220AB

Circuit diagram

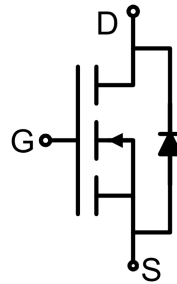

Marking

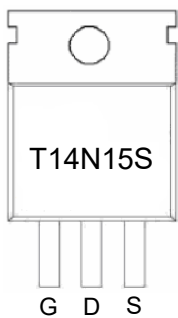

Absolute maximum ratings (Ta=25°C unless otherwise noted)

Parameter	Symbol	Value	Unit
Drain-Source Voltage	V_{DS}	150	V
Gate-Source Voltage	V_{GS}	±20	V
Continuous Drain Current	I_D	140	A
Pulsed Drain Current	I_{DM}	440	A
Power Dissipation	P_D	320	W
Thermal Resistance, Junction-to-Case	$R_{\theta JC}$	0.47	°C/W
Single pulse avalanche energy	E_{AS}	1296	mJ
Junction Temperature	T_J	150	°C
Storage Temperature	T_{STG}	-55 ~ +150	°C

Electrical characteristics (T_A=25 °C, unless otherwise noted)

Parameter	Symbol	Test Condition	Min.	Typ.	Max.	Unit
Static Characteristics						
Drain-source breakdown voltage	$V_{(BR)DSS}$	$V_{GS} = 0V, I_D = 250\mu A$	150			V
Zero gate voltage drain current	I_{DSS}	$V_{DS} = 150V, V_{GS} = 0V$			1	μA
Gate-body leakage current	I_{GSS}	$V_{GS} = \pm 20V, V_{DS} = 0V$			±100	nA
Gate threshold voltage	$V_{GS(th)}$	$V_{DS} = V_{GS}, I_D = 250\mu A$	2		4	V
Drain-source on-resistance ¹⁾	$R_{DS(on)}$	$V_{GS} = 10V, I_D = 70A$		5.6	6.2	mΩ
Forward transconductance ¹⁾	g_{FS}	$V_{DS} = 10V, I_D = 70A$	70			S
Dynamic characteristics²⁾						
Input Capacitance	C_{iss}	$V_{DS} = 75V, V_{GS} = 0V, f = 1MHz$		5900		pF
Output Capacitance	C_{oss}			690		
Reverse Transfer Capacitance	C_{rss}			7		
Total Gate Charge	Q_g	$V_{DS} = 75V, V_{GS} = 10V, I_D = 70A$		80		nC
Gate-Source Charge	Q_{gs}			32		
Gate-Drain Charge	Q_{gd}			13		
Turn-on delay time	$t_{d(on)}$	$V_{DD} = 75V, V_{GS} = 10V, I_D = 70A, R_{GEN} = 4.7\Omega$		26		nS
Turn-on rise time	t_r			36		
Turn-off delay time	$t_{d(off)}$			47		
Turn-off fall time	t_f			15		
Source-Drain Diode characteristics						
Diode Forward Current ¹⁾	I_S				140	A
Diode Forward voltage	V_{DS}	$V_{GS} = 0V, I_S = 140A$			1.2	V

Notes:

- 1) Pulse Test: Pulse Width < 300μs, Duty Cycle ≤2%.
- 2) Guaranteed by design, not subject to production testing.

Test Circuit

1) E_{AS} test Circuit

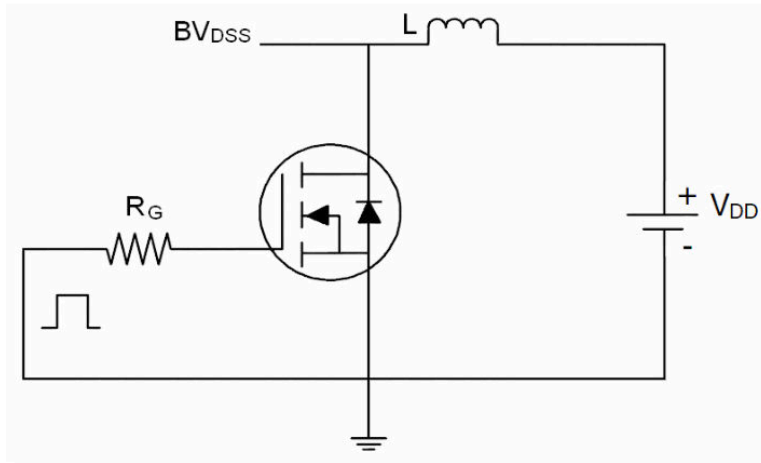

2) Gate charge test Circuit

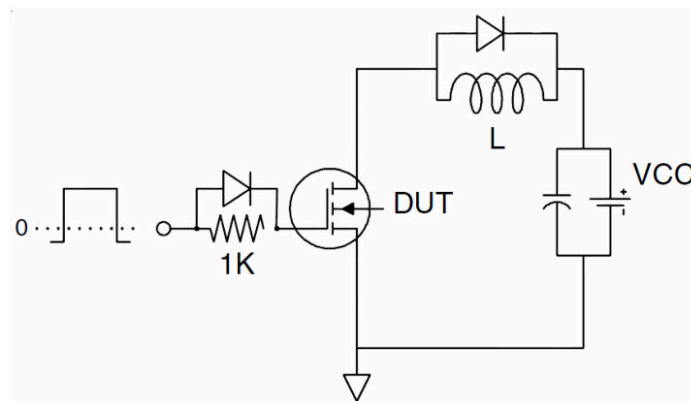

3) Switch Time Test Circuit

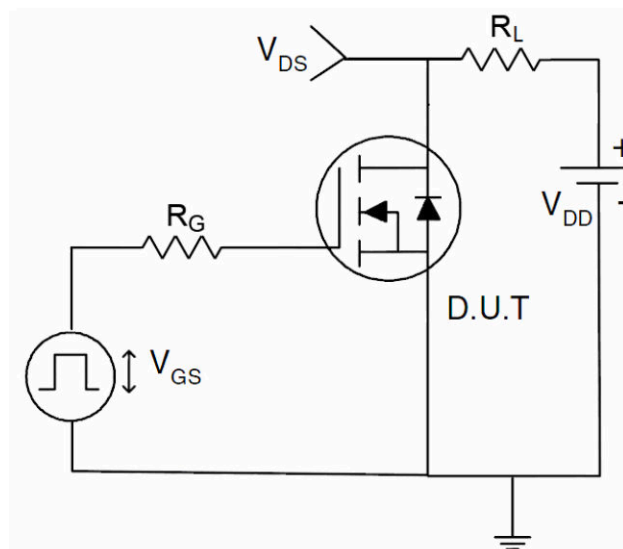

Typical Characteristics

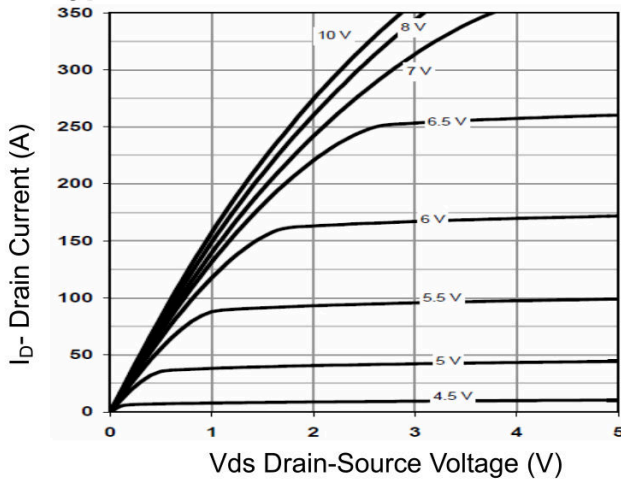

Figure 1 Output Characteristics

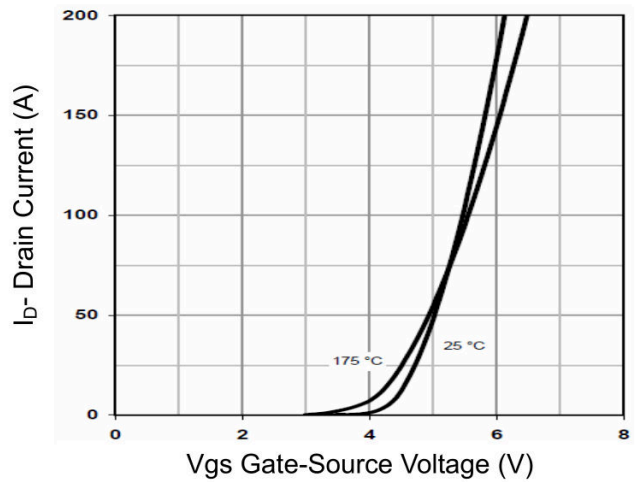

Figure 2 Transfer Characteristics

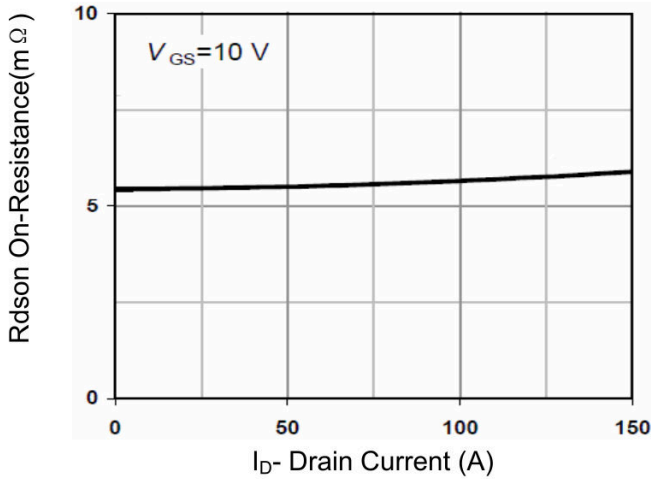

Figure 3 Rdson- Drain Current

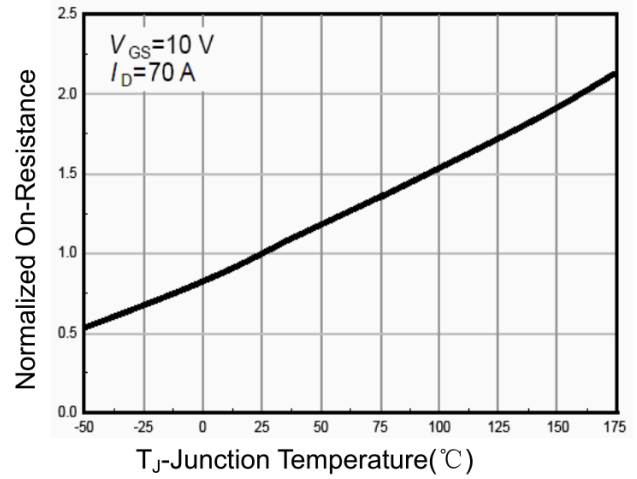

Figure 4 Rdson-Junction Temperature

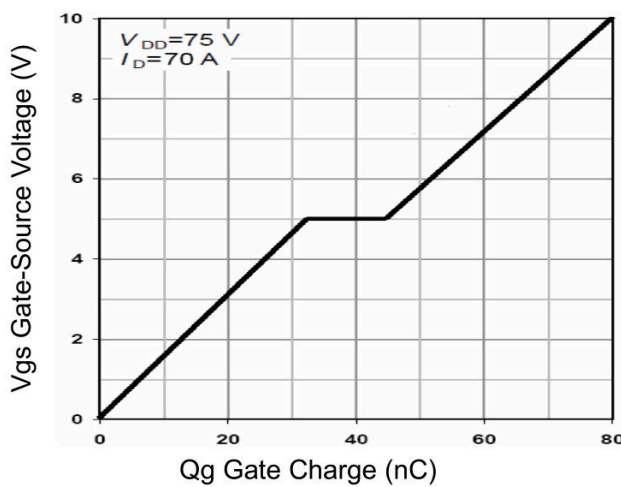

Figure 5 Gate Charge

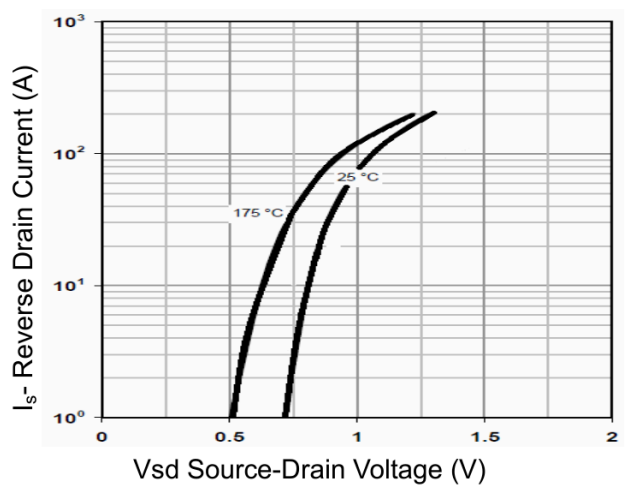

Figure 6 Source- Drain Diode Forward

Typical Characteristics

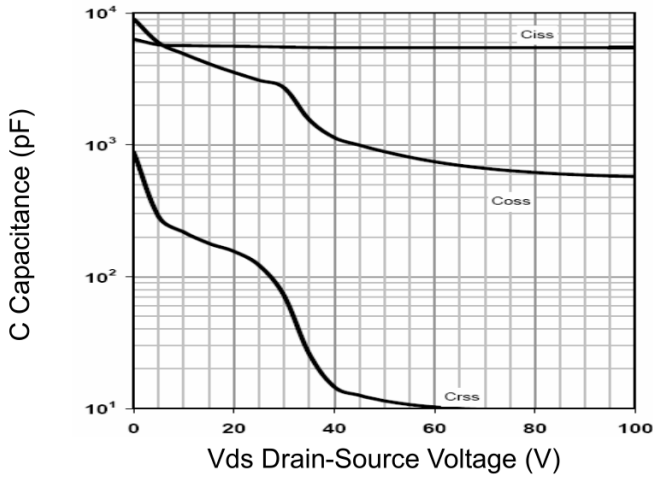

Figure 7 Capacitance vs Vds

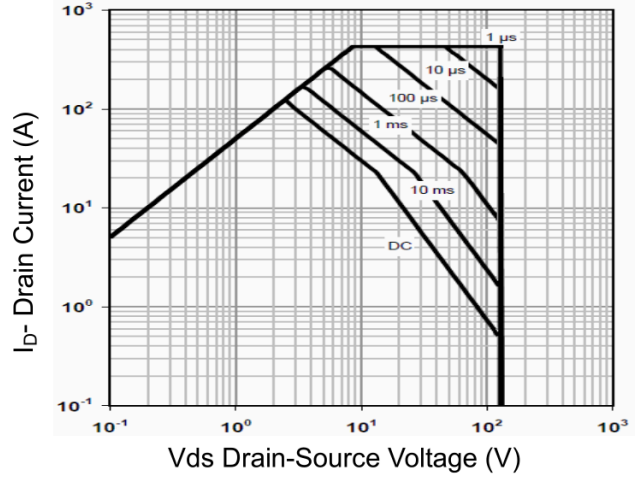

Figure 8 Safe Operation Area

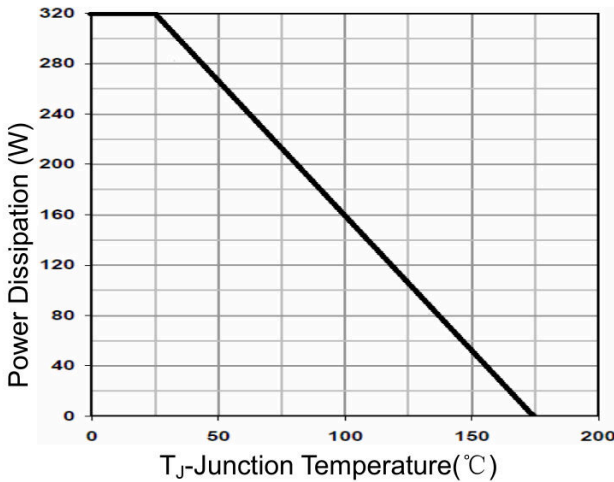

Figure 9 Power De-rating

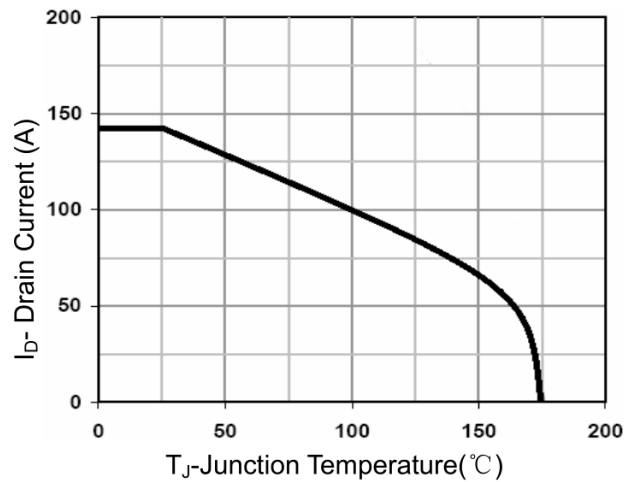

Figure 10 Current De-rating

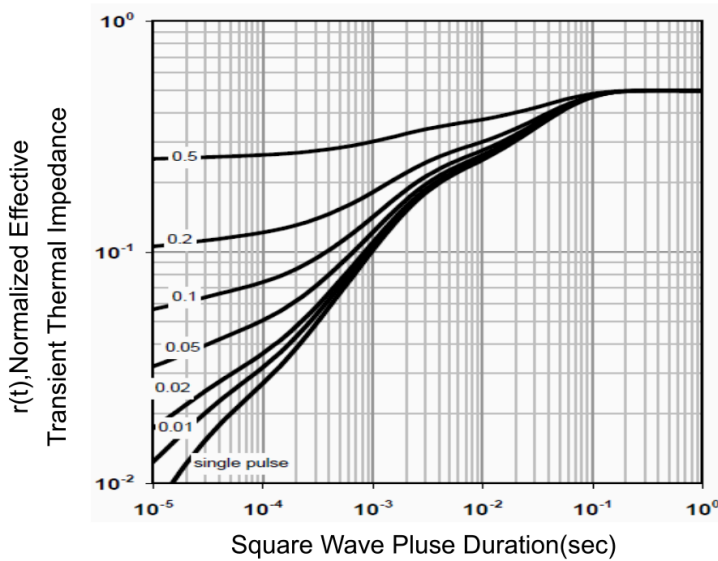
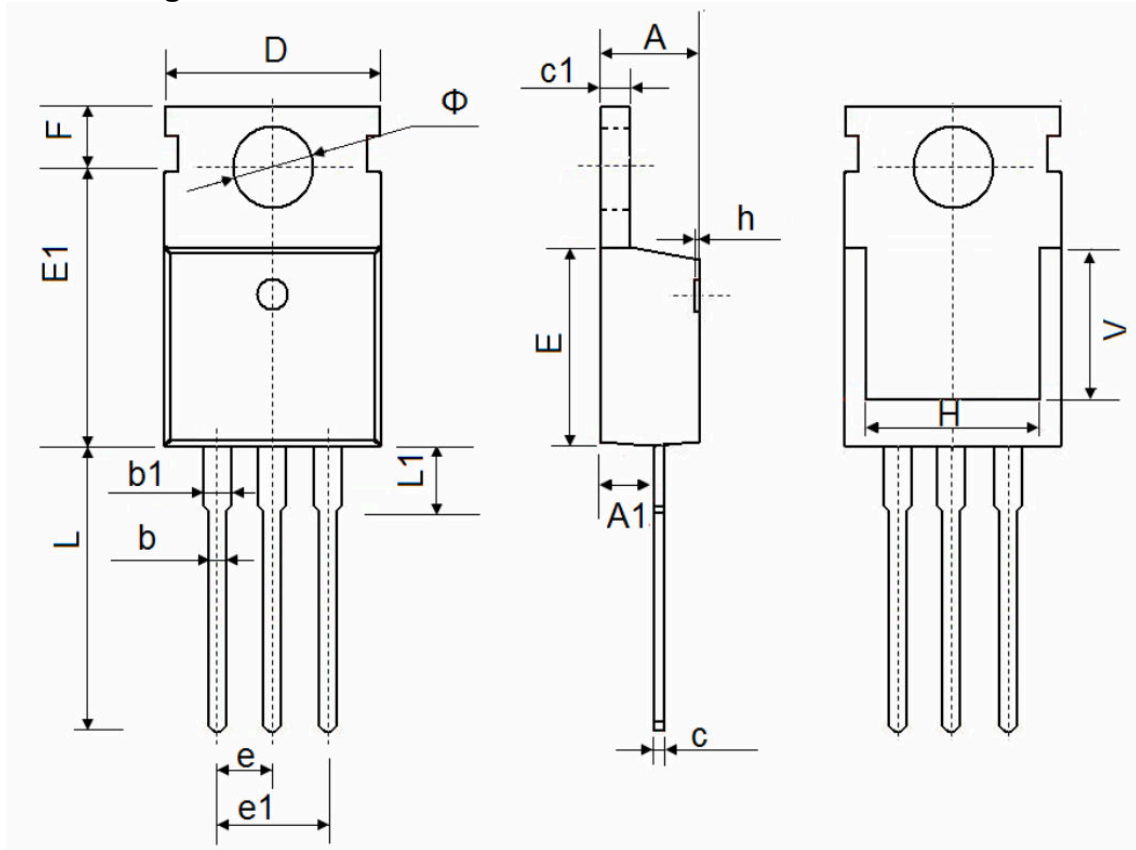

Figure 11 Normalized Maximum Transient Thermal Impedance

TO-220AB Package Information



Symbol	Dimensions In Millimeters		Dimensions In Inches	
	Min.	Max.	Min.	Max.
A	4.400	4.600	0.173	0.181
A1	2.250	2.550	0.089	0.100
b	0.710	0.910	0.028	0.036
b1	1.170	1.370	0.046	0.054
c	0.330	0.650	0.013	0.026
c1	1.200	1.400	0.047	0.055
D	9.910	10.250	0.390	0.404
E	8.9500	9.750	0.352	0.384
E1	12.650	12.950	0.498	0.510
e	2.540 TYP.		0.100 TYP.	
e1	4.980	5.180	0.196	0.204
F	2.650	2.950	0.104	0.116
H	7.900	8.100	0.311	0.319
h	0.000	0.300	0.000	0.012
L	12.900	13.400	0.508	0.528
L1	2.850	3.250	0.112	0.128
V	7.500 REF.		0.295 REF.	
Φ	3.400	3.800	0.134	0.150