

Product Summary

$V_{(BR)DSS}$	$R_{DS(on)MAX}$	I_D
100V	32mΩ@10V	30A

Feature

- High density cell design for ultra low Rdson
- Fully characterized avalanche voltage and current
- Good stability and uniformity with high E_{AS}
- Excellent package for good heat dissipation

Application

- Power switching application
- Hard switched and high frequency circuits
- Uninterruptible power supply

Package

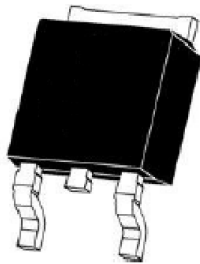

TO-252AB

Circuit diagram

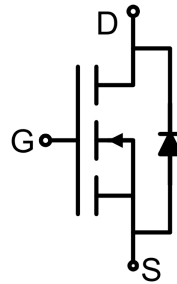

Marking

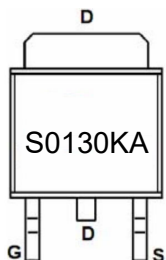

Absolute maximum ratings (Ta=25°C unless otherwise noted)

Parameter	Symbol	Value	Unit
Drain-Source Voltage	V _{DS}	100	V
Gate-Source Voltage	V _{GS}	±20	V
Continuous Drain Current	I _D	30	A
Pulsed Drain Current	I _{DM}	70	A
Power Dissipation	P _D	85	W
Thermal Resistance, Junction-to-Case	R _{θJC}	1.8	°C/W
Single pulse avalanche energy	E _{AS}	256	mJ
Junction Temperature	T _J	150	°C
Storage Temperature	T _{STG}	-55 ~ +150	°C

Electrical characteristics (T_A=25 °C, unless otherwise noted)

Parameter	Symbol	Test Condition	Min.	Typ.	Max.	Unit
Static Characteristics						
Drain-source breakdown voltage	V _{(BR)DSS}	V _{GS} = 0V, I _D = 250μA	100			V
Zero gate voltage drain current	I _{DSS}	V _{DS} = 100V, V _{GS} = 0V			1	μA
Gate-body leakage current	I _{GSS}	V _{GS} = ±20V, V _{DS} = 0V			±100	nA
Gate threshold voltage	V _{GS(th)}	V _{DS} = V _{GS} , I _D = 250μA	1.3		2.5	V
Drain-source on-resistance ¹⁾	R _{DS(on)}	V _{GS} = 10V, I _D = 10A		25	32	mΩ
Forward transconductance ¹⁾	g _{FS}	V _{DS} = 5V, I _D = 10A		15		S
Dynamic characteristics²⁾						
Input Capacitance	C _{iss}	V _{DS} = 50V, V _{GS} = 0V, f = 1MHz		2356		pF
Output Capacitance	C _{oss}			94		
Reverse Transfer Capacitance	C _{rss}			83.3		
Total Gate Charge	Q _g	V _{DS} = 50V, V _{GS} = 10V, I _D = 10A		61.7		nC
Gate-Source Charge	Q _{gs}			8.3		
Gate-Drain Charge	Q _{gd}			16.7		
Turn-on delay time	t _{d(on)}	V _{DD} = 50V, V _{GS} = 10V, R _L = 5Ω, R _{GEN} = 3Ω		7		nS
Turn-on rise time	t _r			7		
Turn-off delay time	t _{d(off)}			29		
Turn-off fall time	t _f			7		
Source-Drain Diode characteristics						
Diode Forward Current ¹⁾	I _S				30	A
Diode Forward voltage	V _{DS}	V _{GS} = 0V, I _S = 10A			1.2	V
Reverse Recovery Time	t _{rr}	T _J = 25°C, I _F = 10A di/dt = 100A/μs ¹⁾		32		nS
Reverse Recovery Charge	Q _{rr}			53		nC

Notes:

1) Pulse Test: Pulse Width < 300μs, Duty Cycle ≤2%.

2) Guaranteed by design, not subject to production testing.

Test Circuit

1) E_{AS} test Circuit

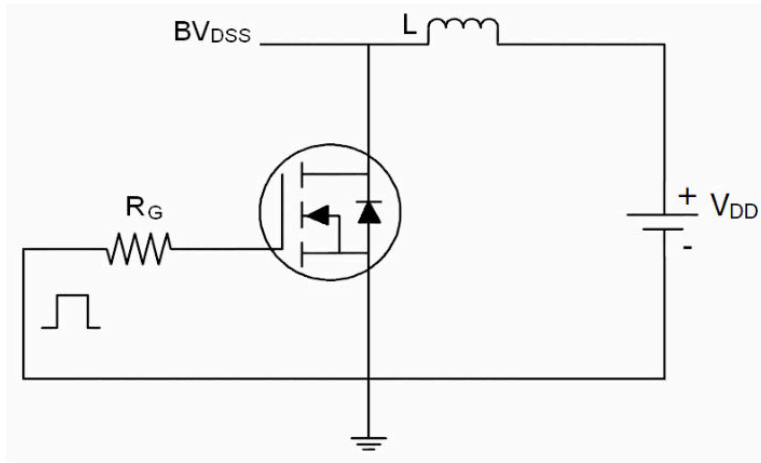

2) Gate charge test Circuit

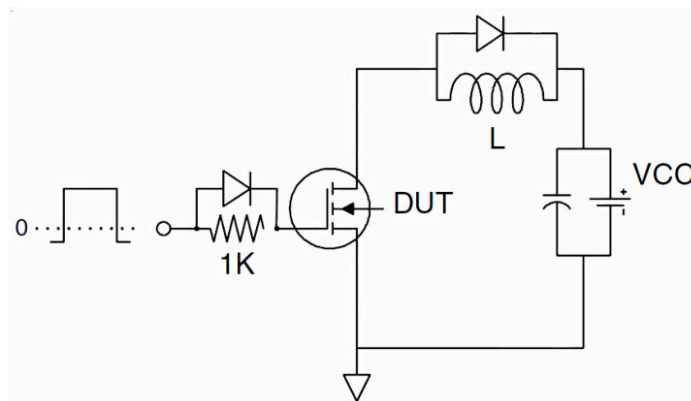

3) Switch Time Test Circuit

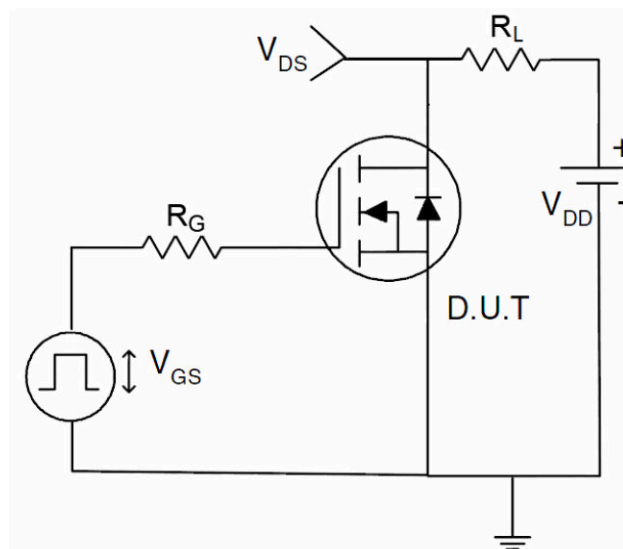

Typical Characteristics

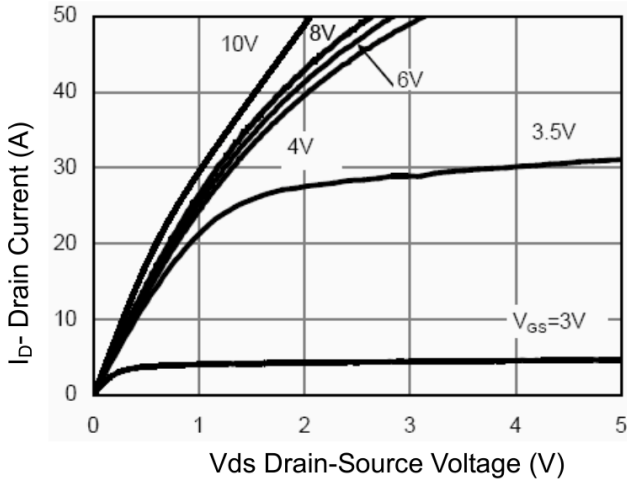

Figure 1 Output Characteristics

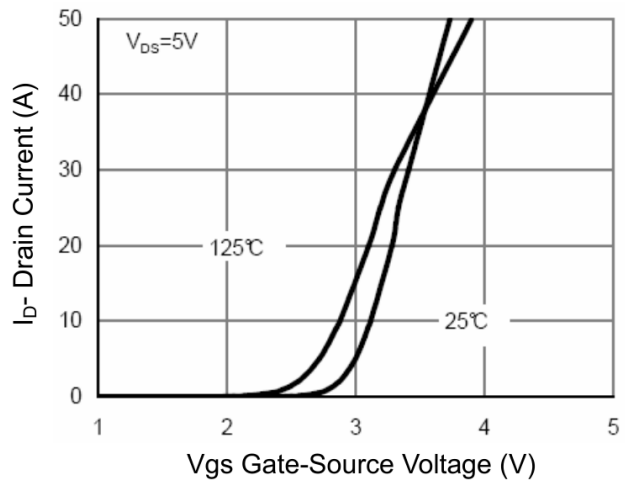

Figure 2 Transfer Characteristics

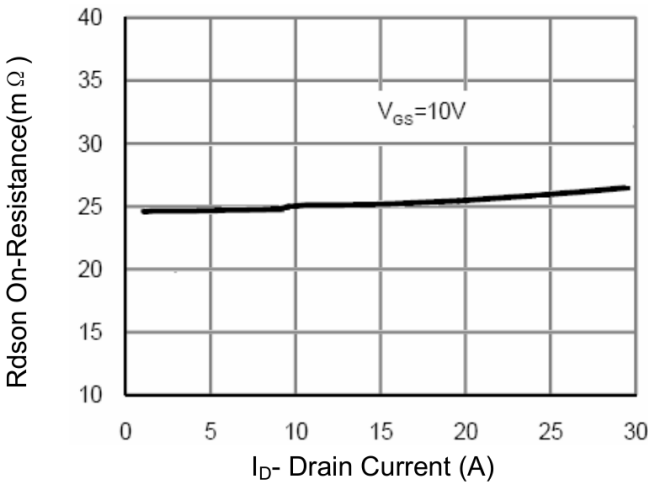

Figure 3 Rdson- Drain Current

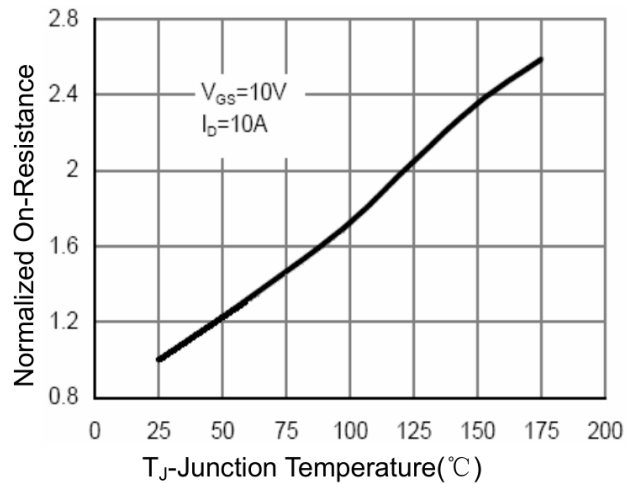

Figure 4 Rdson-Junction Temperature

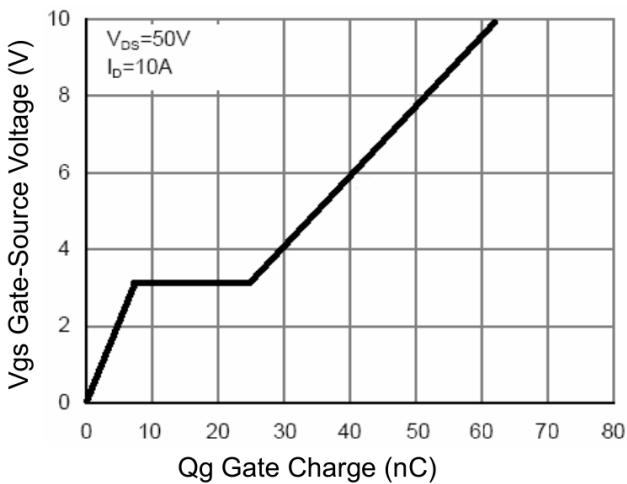

Figure 5 Gate Charge

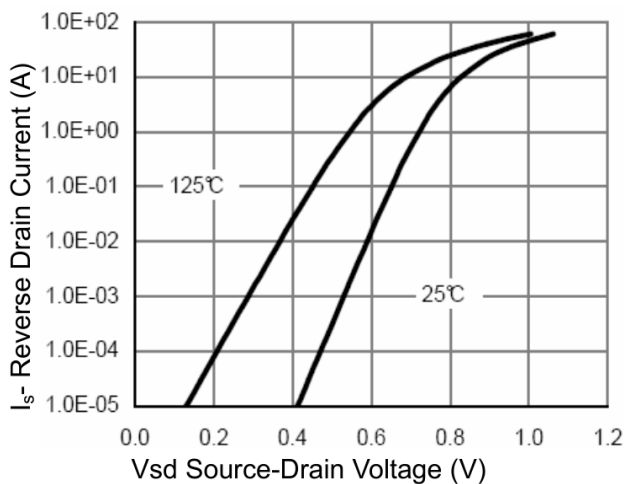

Figure 6 Source- Drain Diode Forward

Typical Characteristics

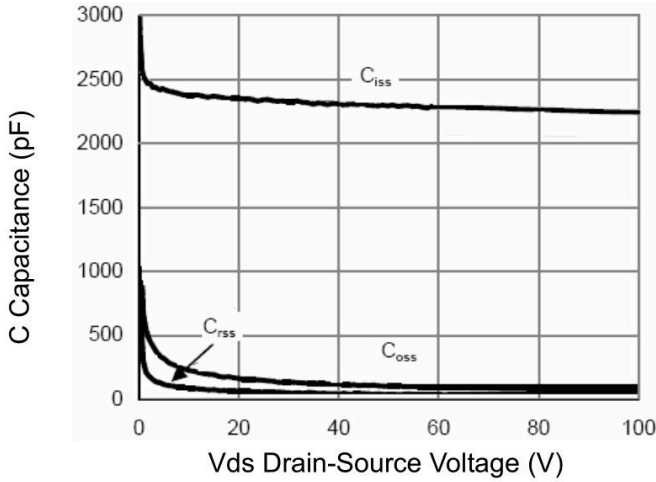

Figure 7 Capacitance vs Vds

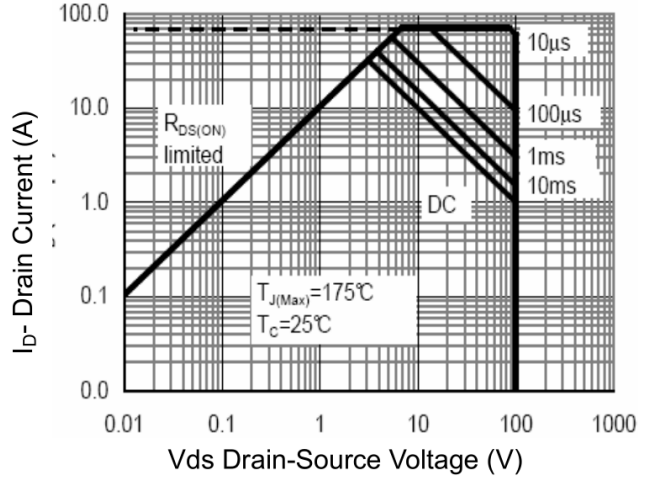

Figure 8 Safe Operation Area

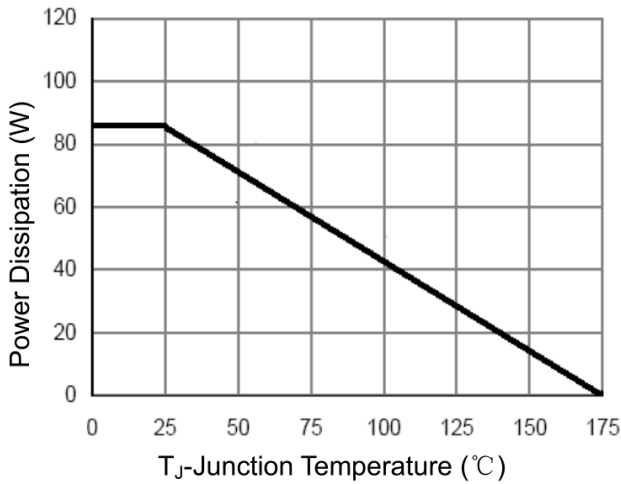

Figure 9 Power De-rating

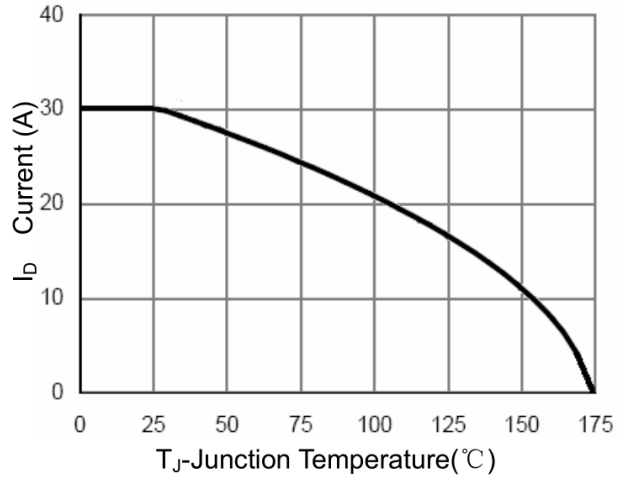

Figure 10 Id Current- Junction Temperature

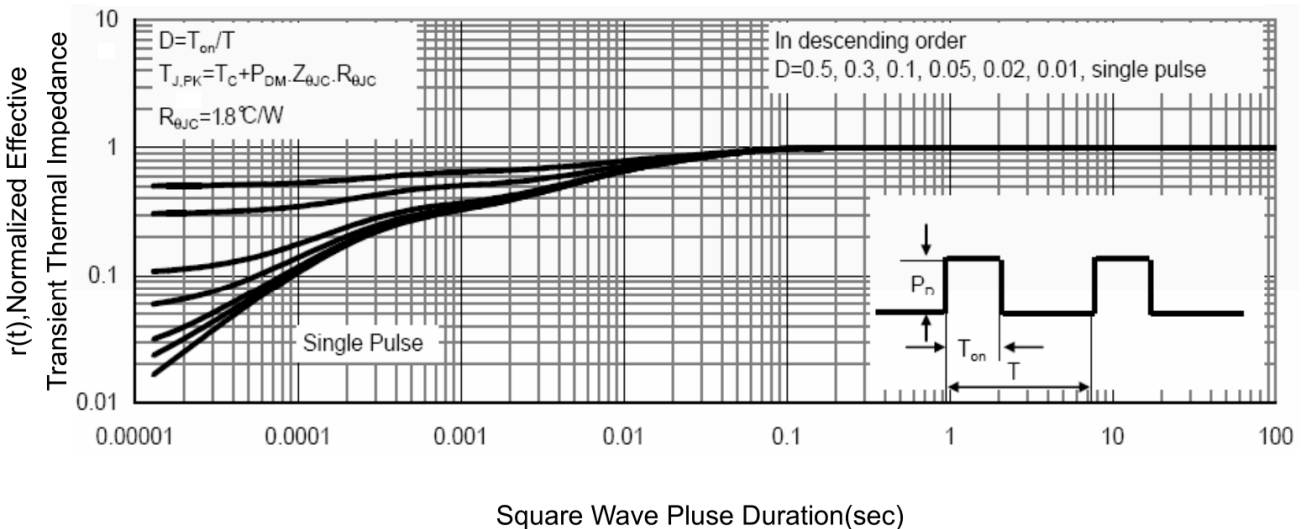
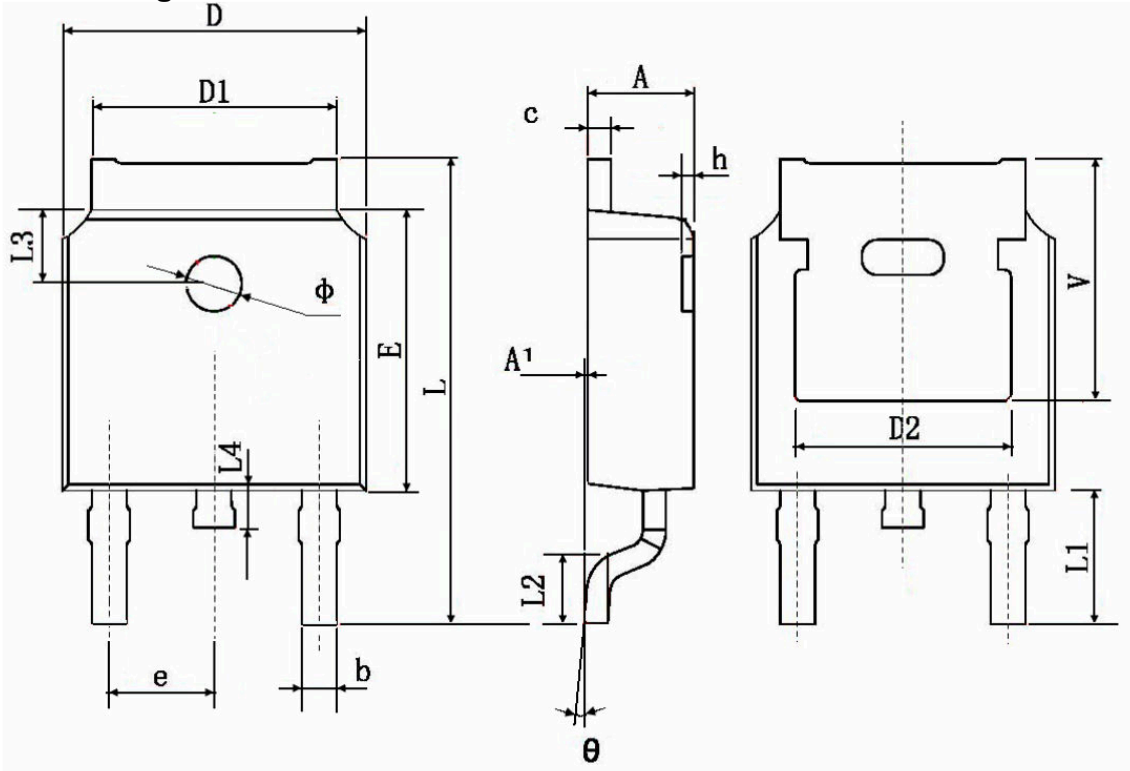

Figure 11 Normalized Maximum Transient Thermal Impedance

TO-252AB Package Information



Symbol	Dimensions In Millimeters		Dimensions In Inches	
	Min.	Max.	Min.	Max.
A	2.200	2.400	0.087	0.094
A1	0.000	0.127	0.000	0.005
b	0.660	0.860	0.026	0.034
c	0.460	0.580	0.018	0.023
D	6.500	6.700	0.256	0.264
D1	5.100	5.460	0.201	0.215
D2	4.830 TYP.		0.190 TYP.	
E	6.000	6.200	0.236	0.244
e	2.186	2.386	0.086	0.094
L	9.800	10.400	0.386	0.409
L1	2.900 TYP.		0.114 TYP.	
L2	1.400	1.700	0.055	0.067
L3	1.600 TYP.		0.063 TYP.	
L4	0.600	1.000	0.024	0.039
Φ	1.100	1.300	0.043	0.051
θ	0°	8°	0°	8°
h	0.000	0.300	0.000	0.012
V	5.350 TYP.		0.211 TYP.	