

**Specification for Approval**



Customer: 立创

Customer P/N: \_\_\_\_\_

Product Name: Power Inductors

Coilank P/N: APW12A45M150

[  New Released,  Revised ]

Approved by	Checked by	Prepared by
	Jean.lin	Bruce.lan

**Coilank Technology Co.,Ltd**

ADD: No.39, Chingao Rd.,(305)Hsinpu, Hs inchu Hsien Taiwan, R.O.C  
 TEL : 00886-3-5894523 FAX : 00886-3-5894415  
 ADD: Unit D, 16/F Cheuk Nang Plaze 250 Hennessy Road, Wanchai HongKong  
 TEL : 00852-31135161 FAX : 00852-31121631  
 SZ Office TEL : 0755-29452870/3 FAX : 0755-61658369  
 HTTP : www.coilank.com E-mail : [sales@coilank.com](mailto:sales@coilank.com)

<b>【For Customer approval Only】</b>		Date: _____
Qualification Status:	<input type="checkbox"/> Full	<input type="checkbox"/> Restricted <input type="checkbox"/> Rejected
<b>Approved By</b>	<b>Verified By</b>	<b>Checked By</b>
Comments: _____		



### 1. External Dimensions (Unit:m/m)

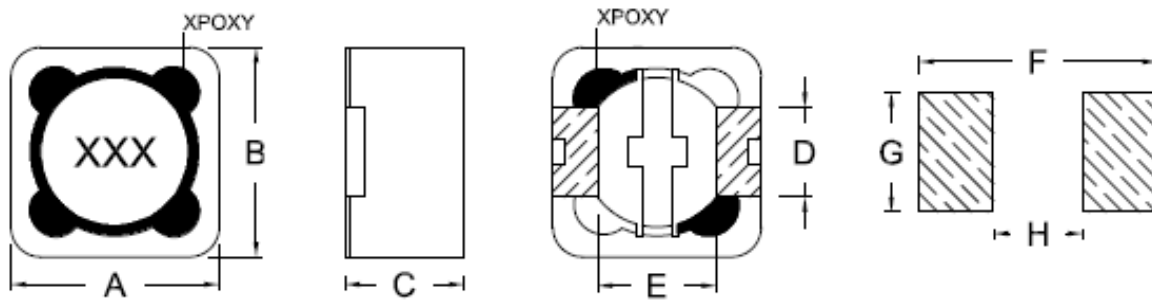

TYPE	A	B	C	D	E	F	G	H	Q'TY/Reel
APW12A45	12.5Max	12.5Max	4.5Max	5.0Ref	7.6Ref	12.6Ref	5.4Ref	7.0Ref	500

### 2. Part Number Code

$\frac{APW}{A}$      $\frac{12}{B}$      $\frac{A}{C}$      $\frac{45}{D}$      $\frac{M}{E}$      $\frac{150}{F}$

- A: Series Name                      Power Inductors
- B: Dimensions(mm)                12: 12.5x12.5 Max
- C: Materials                         NO use
- D: Thickness(mm)                 45: 4.5 Max
- E: Tolerance                         M: ±20%
- F: Inductance                        150=15uH

### 3. Electrical Characteristics

Part Number	Inductance (uH)	Test Frequency (KHz)	DC Resistance (mΩ)Max.	Saturation Current (A)Max.
APW12A45M150	15.0	100KHz/0.25V	50.0	3.5

#### Notes:

- 1) AEC-Q200 qualified.
- 2) All test data is referenced to 25°C ambient.
- 3) Operating temperature range -40°C to +125°C.
- 4) Isat: DC current(A) that will cause I<sub>o</sub> to drop approximately 35%.
- 5) The part temperature(ambient + temp rise)should not exceed 125°C under worst case operating conditions. circuit design,component placement, PWB trace size and thickness,airflow and other cooling provisions all affect the part temperature,part temperature should be verified in the end application.

## 4. Test Data

ELECTRICAL CHARACTERISTIC				MECHANICAL DIMENSIONS				
SPEC	L(uH)	DCR(mΩ)	Isat(uH)	A(mm)	B(mm)	C(mm)	D(mm)	
TOL	15.0	50.0	3.5A	12.5	12.5	4.5	5.0	
NO	±20%	Max	(LOA-L3.5A) /LOA≤35%	Max	Max	Max	Ref	
1	15.52	36.56	14.06	12.03	11.99	4.26	OK	
2	15.46	36.63	14.02	11.99	12.01	4.28	OK	
3	15.49	36.46	14.08	11.98	12.01	4.28	OK	
4	15.52	36.72	14.13	12.03	11.99	4.30	OK	
5	15.56	37.06	14.05	12.02	12.01	4.27	OK	
6	15.56	37.04	14.13	11.99	12.01	4.29	OK	
7	15.62	36.85	14.05	11.97	11.98	4.26	OK	
8	15.46	36.89	14.13	12.01	12.01	4.27	OK	
9	15.49	37.06	14.16	11.99	11.99	4.25	OK	
10	15.63	36.93	14.05	12.02	11.99	4.28	OK	
Test Equipmets: IM3536,VR126,VR7210,Calipers								

## 5. Test and Measurement Procedures

### 5.1 Test Conditions

5.1.1 Unless otherwise specified, the standard atmospheric conditions for measurement/test as:

- Ambient Temperature: 20±15℃
- Relative Humidity: 65%±20%
- Air Pressure: 86KPa to 106KPa

5.1.2 If any doubt on the results, measurements/tests should be made within the following limits:

- Ambient Temperature: 20±2℃
- Relative Humidity: 65%±5%
- Air Pressure: 86KPa to 106Kpa

### 5.2 Visual Examination

- Inspection Equipment: 10X magnifier

### 5.3 Electrical Test

5.3.1 Inductance (L)

- Refer to the third item.
- Test equipment: IM3536 LCR meter or equivalent.
- Test Frequency and Voltage: Refer to the third item.

5.3.2 Direct Current Resistance (DCR)

- Refer to the third item.
- Test equipment: VR126 or equivalent.

5.3.3 Current

- Refer to the third item.
- Test equipment (see Fig.5.3.3-1): Electric Power, Electric current meter, Thermometer.
- Measurement method (see Fig. 5.3.3-1):

1. Set test current to be 0 mA.
  2. Measure initial temperature of chip surface.
  3. Gradually increase voltage and measure chip temperature for corresponding current.
- d. Definition of Temperature rise current: DC current that causes the temperature rise ( $\Delta T = 40^{\circ}\text{C}$ ) from  $20^{\circ}\text{C}$  ambient (see Fig. 5.3.3-2).

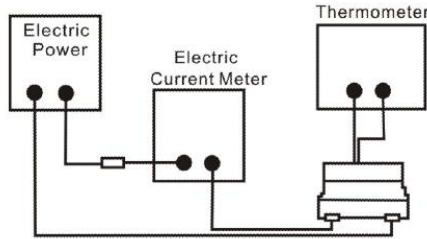

Fig.5.3.3-1

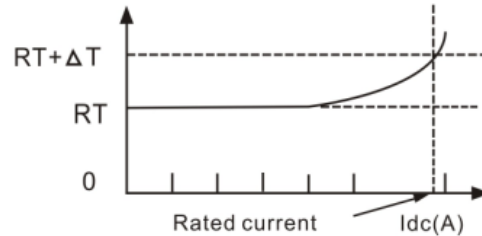
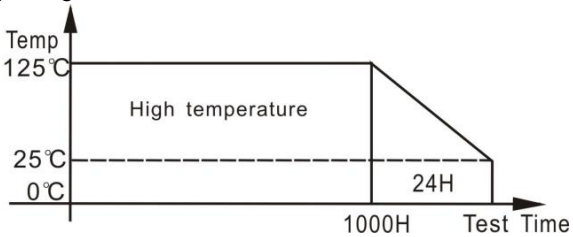
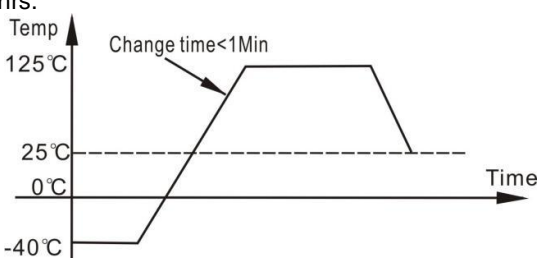
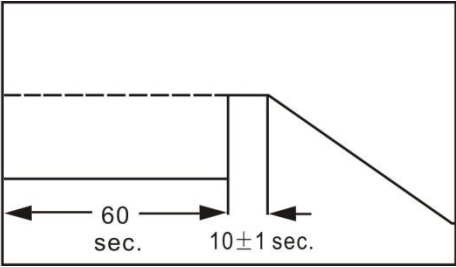
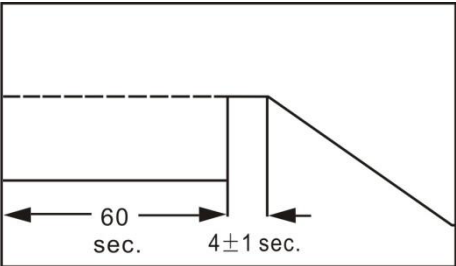

Fig.5.3.3-2

### 5.4 Reliability Test

Item	Specifications	Test conditions
5.4.1 High temperature storage test	No visible mechanical damage. Inductance change: Within $\pm 10\%$ .	Temperature: $125 \pm 2^{\circ}\text{C}$ . Duration: 1000hrs. Measured at room temperature after placing for $24 \pm 4$ hrs. 
5.4.2 Temperature cycling test	No visible mechanical damage. Inductance change: Within $\pm 10\%$ .	Condition for 1 cycle. Step1: $-40 \pm 2^{\circ}\text{C}$ 30min Min. Step2: $125 \pm 2^{\circ}\text{C}$ , transition time 1min Max. Step3: $125 \pm 2^{\circ}\text{C}$ 30min Min. Step4: Low temp, transition time 1min Max. Number of cycles: 1000. Measured at room temperature after placing for $24 \pm 4$ hrs. 
5.4.3 Biased humidity test	No visible mechanical damage. Inductance change: Within $\pm 10\%$ .	Humidity : $85\% \pm 3$ RH. Temperature: $85^{\circ}\text{C} \pm 2^{\circ}\text{C}$ . Duration : 1000hrs. Measured at room temperature after placing for $24 \pm 4$ hrs.

Item	Specifications	Test conditions
5.4.4 Operational life test	No visible mechanical damage. Inductance change: Within $\pm 10\%$ .	Temperature: $105 \pm 2^\circ\text{C}$ . Duration :1000hrs. Measured at room temperature after placing for $24 \pm 4$ hrs.
5.4.5 Resistance to solvent test	No visible mechanical damage. Inductance change: Within $\pm 10\%$ .	Add aqueous wash chemical - OKEM clean or equivalent.
5.4.6 Vibration test	No visible mechanical damage. Inductance change: Within $\pm 10\%$ .	Oscillation Frequency: $10 \sim 2\text{K} \sim 10\text{Hz}$ for 20 minute. Total Amplitude: $1.52\text{mm} \pm 10\%$ . Testing Time : 12 hours(20 minutes, 12 cycles each of 3 orientations).
5.4.7 Resistance to soldering heat test	No visible mechanical damage. Inductance change: Within $\pm 10\%$ .	Temperature ( $^\circ\text{C}$ ): $260 \pm 5$ (solder temp). Time (s): $10 \pm 1$ . ramp/immersion and emersion rate: $25\text{mm/s} \pm 6 \text{ mm/s}$ . Number of heat cycles:1. 
5.4.8 Solderability test	More than 95% of the terminal electrode should be covered with solder.	Steam Aging: 8 hours $\pm$ 15 min. Preheat: $150^\circ\text{C}$ , 60sec. Solder: Sn99.5%-Cu0. 5%. Temperature: $245 \pm 5^\circ\text{C}$ . Flux for lead free: Rosin. 9.5%. Dip time: $4 \pm 1$ sec. Depth: completely cover the termination. 
5.4.9 Terminal strength (SMD) test	No visible mechanical damage.	With the component mounted on a PCB with the device to be tested, apply a 17.7 N (1.8 Kg) force to the side of a device being tested. This force shall be applied for $60 \pm 1$ seconds. Also the force shall be applied radually as not to apply a shock to the component being tested.

### 6. Packaging, Storage

#### 6.1 Tape and Reel Packaging Dimensions

##### 6.1.1 Taping Dimensions (Unit: mm)

Please refer to Fig. 6.1.1-1

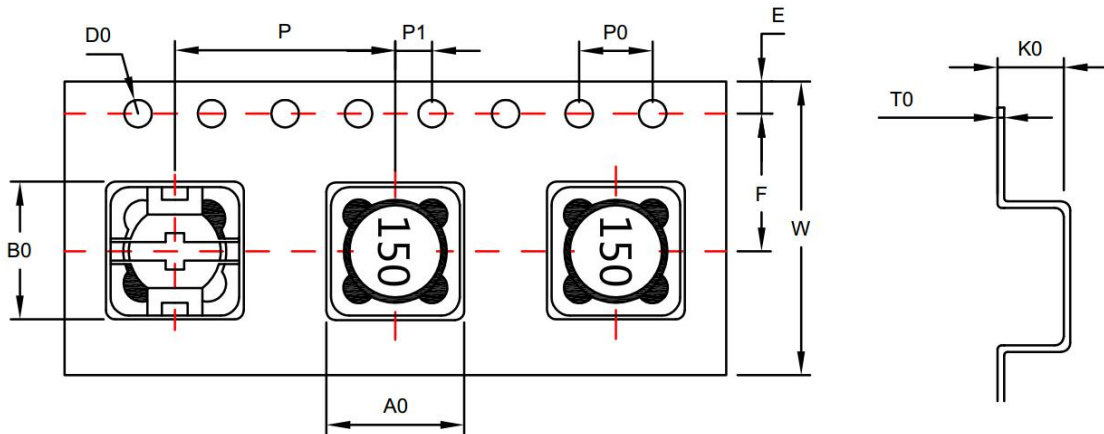

6.1.1-1

TYPE	A0	B0	W	E	F	P0	P	P1	D0	T0	K0
APW12A45	12.7±0.1	12.7±0.1	24.0±0.3	1.75±0.1	11.5±0.1	4.0±0.1	16.0±0.1	2.0±0.1	1.5±0.1	0.4±0.1	4.8±0.1

##### 6.1.2 Reel Dimensions (Unit: mm)

Please refer to Fig. 6.1.2-1.

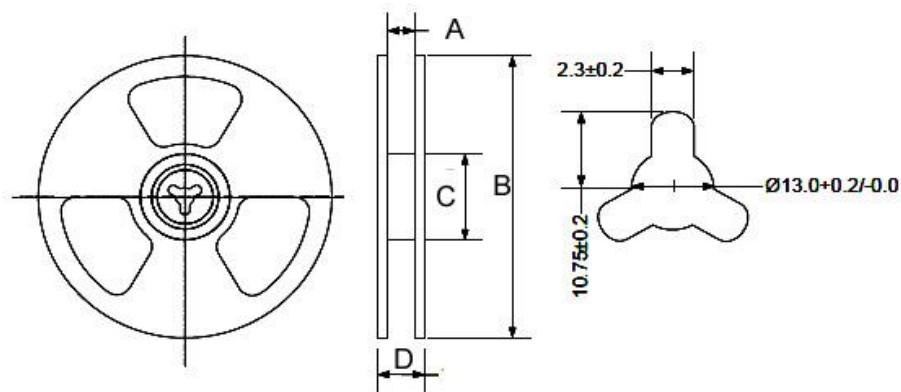

Fig. 6.1.2-1.

TYPE	A	B	C	D
APW12A45	24.5±2.0	330.0±2.0	100.0±2.0	28.5±2.0

### 6.2 Packaging

6.2.1 The inner box specification: 350\*340\*40MM

Packing quantity: 500PCS/ box

Bubble bag : 37\*45CM

Job description: putting the air bubble bag products placed inside the box, sealed with scotch tape

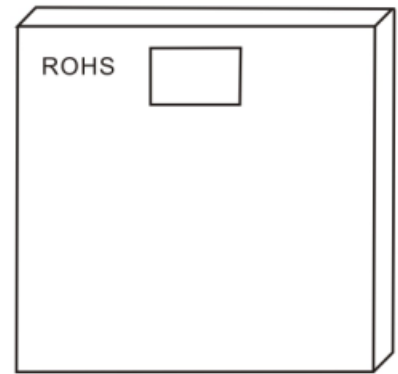

6.2.2 The outside box specification: 370\*360\*165MM

Packing quantity: 1500PCS/ box

Job description: will be outside the box bottom sealed, inner box into the box.

- a. With transparent tape sealed box at the top
- b. The specified location with a box labels in the outer box.
- c. If the mantissa box under a FCL with inner box or filling full

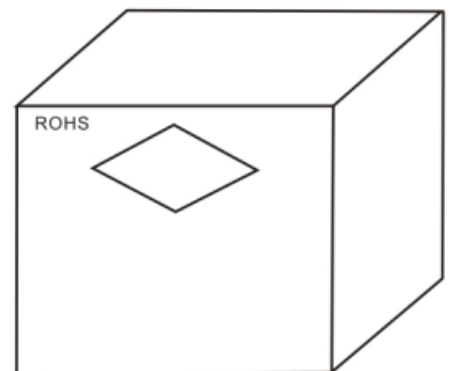

### 6.3 Storage

- a. To maintain the solderability of terminal electrodes and to keep the packing material in good condition, temperature and humidity in the storage area should be controlled.
- b. Recommended conditions: -10°C~40°C, 70%RH (Max.)
- c. The ambient temperature must be kept below 30°C. Even under ideal storage conditions, solderability of products electrodes may decrease as time passes. For this reason, product should be used with one year from the time of delivery.
- d. In case of storage over 6 months, solderability shall be checked before actual usage.



### 7. Recommended Soldering Technologies

#### 7.1 Re-flowing Profile:

- △ Preheat condition: 150~200°C/60~120sec.
- △ Allowed time above 217°C: 60~90sec.
- △ Max temp: 260°C
- △ Max time at max temp: 5sec.
- △ Solder paste: Sn/3.0Ag/0.5Cu
- △ Allowed Reflow time: 2x max

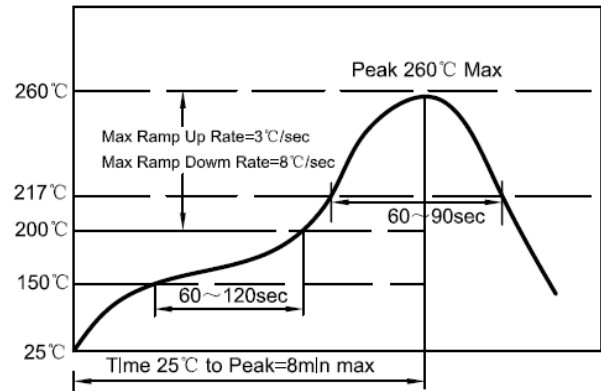

#### 7.2 Iron Soldering Profile:

- △ Iron soldering power: Max.30W
- △ Pre-heating: 150°C/60sec.
- △ Soldering Tip temperature: 350°C Max.
- △ Soldering time: 3sec Max.
- △ Solder paste: Sn/3.0Ag/0.5Cu
- △ Max.1 times for iron soldering

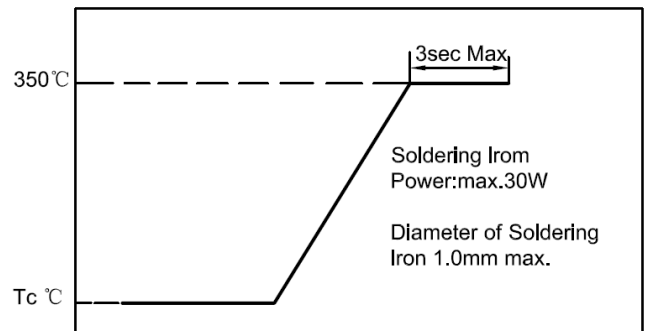

[Note: Take care not to apply the tip of the soldering iron to the]