



600KHz 36V/1.2A Synchronous Step-down Converter

General Description

The LP6498A is a synchronous step-down regulator from a high voltage input supply. Operating with an input voltage range from 4.5V to 30V. 1.2A continuous output current. The converter integrates a main switch and a synchronous rectifier for high efficiency without an external Schottky diode. LP6498A Requires a minimum number of readily available standard external components. over current protection and thermal shutdown. output short circuit protection.

The LP6498A converters are available in the industry standard SOT23-6 packages.

Features

- ◆ Input Voltage Range: 4.5V to 30V
- ◆ Output Voltage Range: 0.8V to 12V
- ◆ 1200mA Load Current
- ◆ Up to 93% Efficiency
- ◆ 600KHz Switching Frequency
- ◆ Short Circuit Protection
- ◆ Thermal Fault Protection
- ◆ SOT23-6 Package
- ◆ RoHS Compliant and 100% Lead (Pb)-Free

Order Information

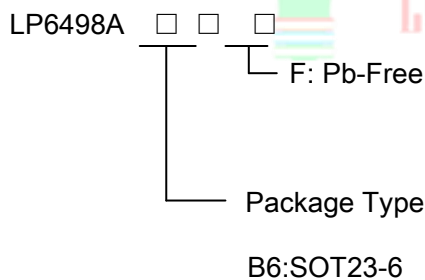

Typical Application Circuit

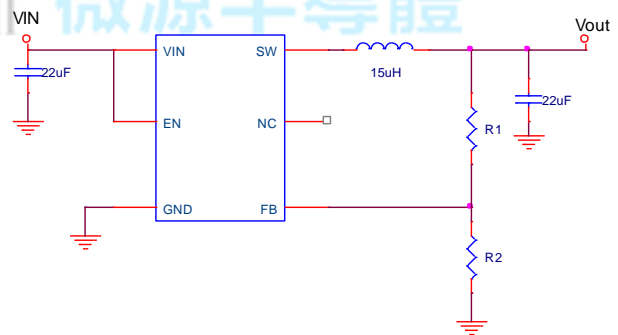

Applications

- ✧ Car Charger / Adaptor
- ✧ Pre-Regulator for Linear Regulators
- ✧ Distributed Power Systems
- ✧ USB Dedicated Charging Ports (DCP)

Marking Information

Device	Marking	Package	Shipping
LP6498AB6F	LPS AOYWX	SOT23-6	3K/REEL
Marking indication: Y: Year code. W: Week code. X: Batch numbers.			



Functional Pin Description

Package Type	SOT23-6(Top View)
Pin Configurations	

Pin Description

PIN	Name	Description
1	NC	No connection.
2	GND	Ground.
3	FB	Feedback Input. $V_{out} = \left(\frac{R1}{R2} + 1\right) \times V_{FB}$
4	EN	Enable Pin
5	VIN	Voltage supply.
6	SW	Switch Mode Connection to Inductor. This pin connects to the drains of the internal main and synchronous power MOSFET switches.



Function Diagram

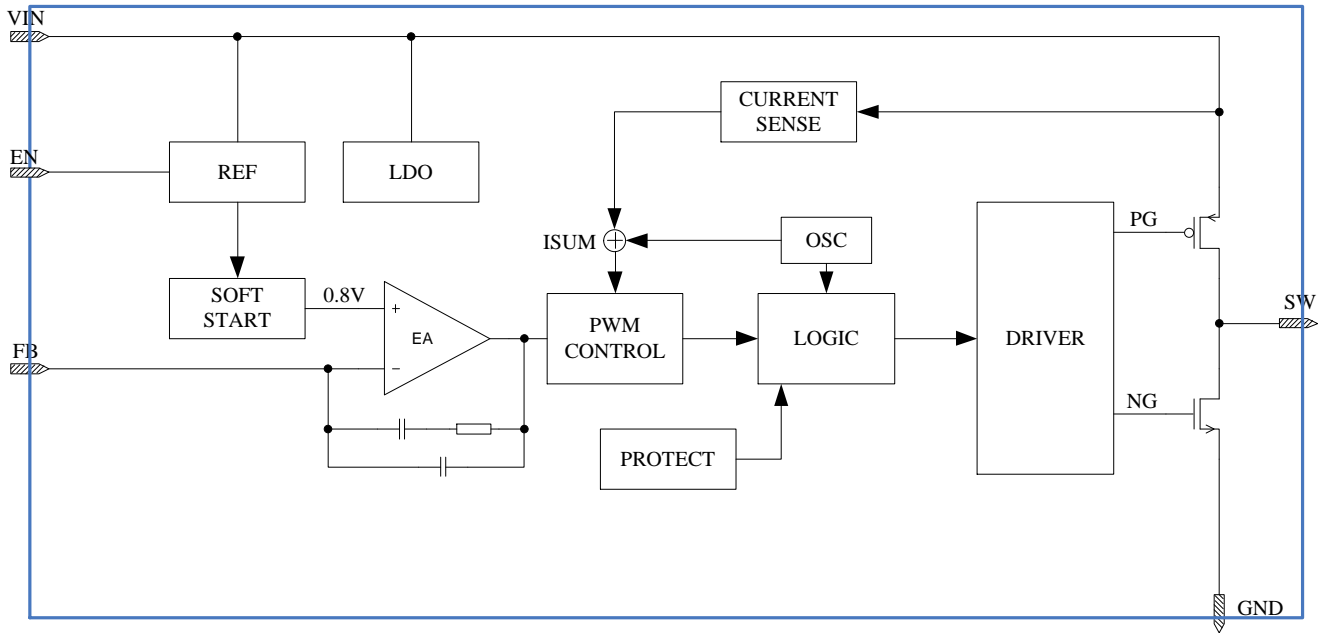

Absolute Maximum Ratings ^{Note 1}

- ✧ VIN\SW \EN to GND ----- -0.3V to 36V
- ✧ VOUT\LED\RV\FB to GND ----- -0.3V to 6.5V
- ✧ Maximum Junction Temperature ----- 150°C
- ✧ Storage Temperature ----- -65°C to 165°C
- ✧ Operating Ambient Temperature Range (TA) ----- -20°C to 85°C
- ✧ Maximum Soldering Temperature (at leads, 10 sec) ----- 260°C

Note 1. Stresses beyond those listed under “Absolute Maximum Ratings” may cause permanent damage to the device. These are stress ratings only, and functional operation of the device at these or any other conditions beyond those indicated in the operational sections of the specifications is not implied. Exposure to absolute maximum rating conditions for extended periods may affect device reliability.

Thermal Information

- ✧ Maximum Power Dissipation (SOT23-6, P_D, T_A=25°C) ----- 0.6W
- ✧ Thermal Resistance (SOT23-6, θ_{JA}) ----- 200°C/W

ESD Susceptibility

- ✧ HBM(Human Body Mode) ----- 2KV
- ✧ MM(Machine Mode) ----- 200V



Electrical Characteristics

$V_{IN}=12V$, $V_{EN}=5V$, $T_A=25^{\circ}C$, unless otherwise noted

Symbol	Parameter	Condition	Min	Typ	Max	Units
V_{IN}	Input Voltage		4.5		30	V
V_{FB}	Feedback Threshold Voltage Accuracy		0.784	0.8	0.816	V
I_Q	Quiescent Current	$I_{load}=0mA$		8		mA
V_{UVLO}	V_{IN} Under Voltage Lockout Threshold	V_{IN} Rising		4		V
$V_{UVLO-HYS}$	UVLO Hysteresis			0.5		V
I_{LIM}	P-Channel Current Limit	$T_J=25^{\circ}C$		2.4		A
		$T_J=150^{\circ}C$		1.6		
$R_{DS(ON)_H}$	High-Side Switch On Resistance			240		m Ω
$R_{DS(ON)_L}$	Low-Side Switch On Resistance			130		m Ω
T_{HICCUP}	Hiccup Time			6		mS
T_{SS}	Soft-start Time			0.8		mS
f_{OSC}	Oscillator Frequency			600		KHz
t_{SD}	Over-Temperature Shutdown Threshold			150		$^{\circ}C$
T_{HYS}	Over-Temperature Shutdown Hysteresis			20		$^{\circ}C$



Typical Operating Characteristics

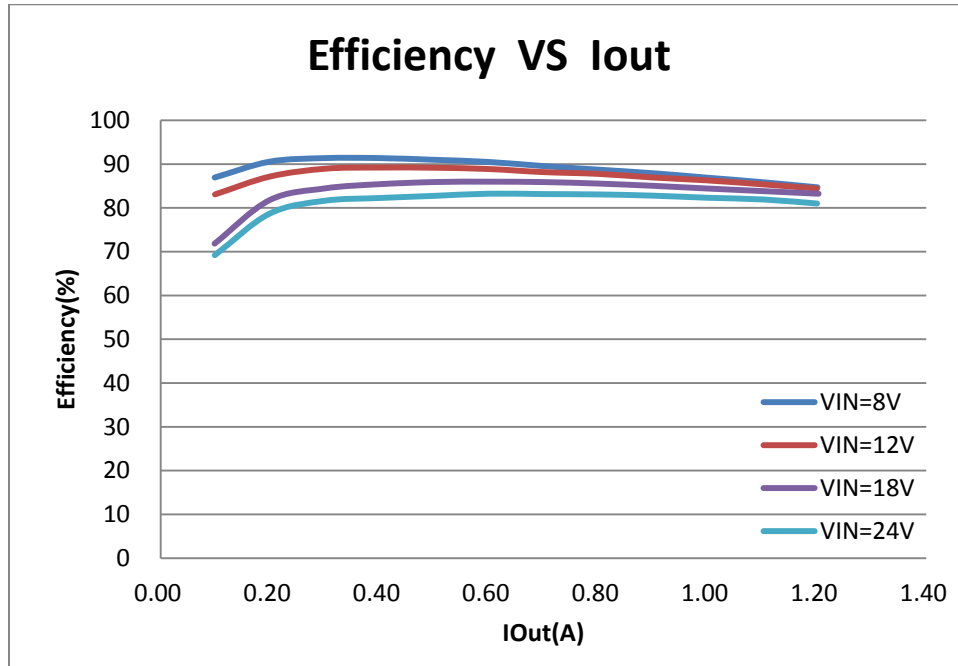



Operation Information

Functional Description

The LP6498A is a switch-mode step-down DC-DC converter. The device operates at a fixed 600KHz switching frequency, and uses a slope compensated current mode architecture. This step-down DC-DC converter can supply up to 1.2A output current at input voltage range from 4.5V to 30V. It minimizes external component size and optimizes efficiency at the heavy load range. The integrated slope compensation allows the device to remain stable over a wider range of inductor values so that smaller values (6.8 μ H to 22 μ H) with lower DCR can be used to achieve higher efficiency.

Layout Guidance

When laying out the PCB board, the following layout guideline should be followed to ensure proper operation of the LP6498A:

1. The power traces, including the GND trace, the SW trace and the IN trace should be kept short, direct and wide to allow large current flow. The L connection to the SW pins should be as short as possible. Use several VIN pads when routing between layers.
2. The input capacitor (C_{IN}) should connect as closely as possible to VIN and GND to get good power filtering.





Packaging Information

SOT23-6

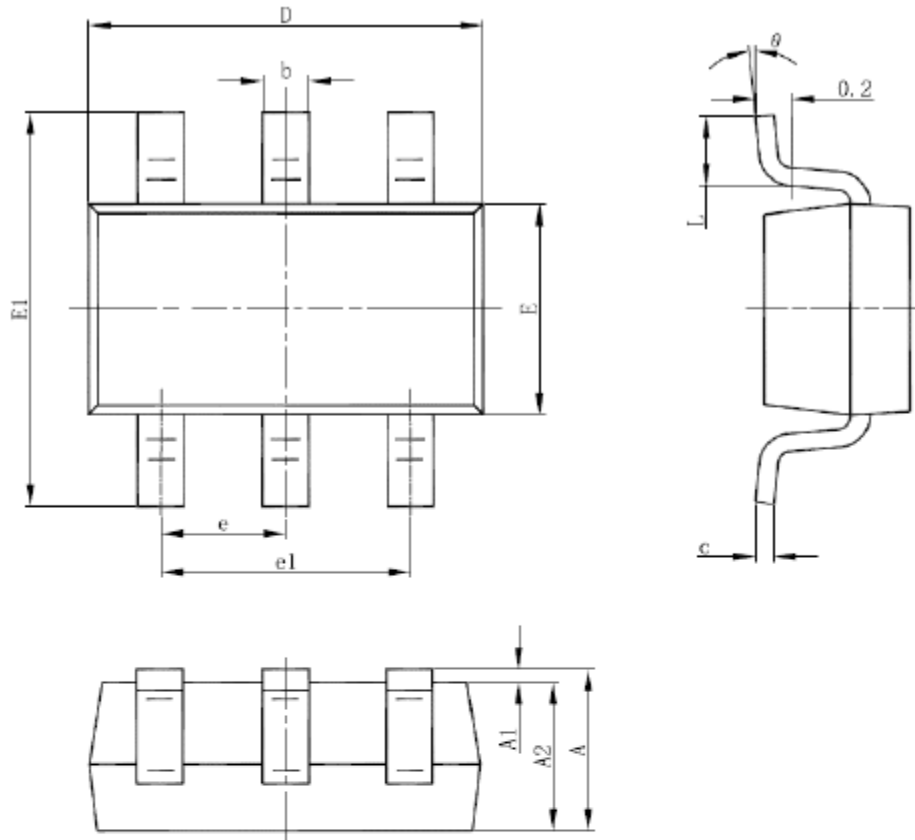

Symbol	Dimensions In Millimeters		Dimensions In Inches	
	Min	Max	Min	Max
A	1.050	1.250	0.041	0.049
A1	0.000	0.100	0.000	0.004
A2	1.050	1.150	0.041	0.045
b	0.300	0.500	0.012	0.020
c	0.100	0.200	0.004	0.008
D	2.820	3.020	0.111	0.119
E	1.500	1.700	0.059	0.067
E1	2.650	2.950	0.104	0.116
e	0.950(BSC)		0.037(BSC)	
e1	1.800	2.000	0.071	0.079
L	0.300	0.600	0.012	0.024
θ	0°	8°	0°	8°