

Specification for Approval



Customer: 立创

Customer P/N: C328273

Product Name: Power Inductors

Coilank P/N: APD03H20N1R5

[New Released, Revised]

Approved by	Checked by	Prepared by
	Jean.lin	Bruce.lan

Coilank Technology Co., Ltd

ADD: No.39, Chingao Rd.,(305)Hsinpu, Hs inchu Hsien Taiwan, R.O.C
 TEL : 00886-3-5894523 FAX : 00886-3-5894415
 ADD: Unit D, 16/F Cheuk Nang Plaze 250 Hennessy Road, Wanchai HongKong
 TEL : 00852-31135161 FAX : 00852-31121631
 SZ Office TEL : 0755-29452870/3 FAX : 0755-61658369
 HTTP : www.coilank.com E-mail : sales@coilank.com

【For Customer approval Only】		Date: _____
Qualification Status:	<input type="checkbox"/> Full	<input type="checkbox"/> Restricted <input type="checkbox"/> Rejected
Approved By	Verified By	Checked By
Comments: _____		

1. External Dimensions (Unit:m/m)

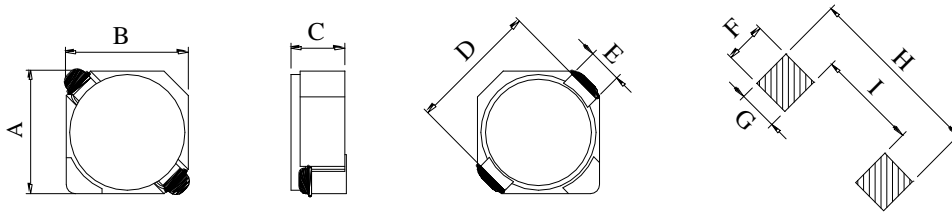

Type	A	B	C	D	E	F	G	H	I	Q'TY/Reel
APD03H20	3.2Max	3.2Max	2.0Max	4.2Max	1.0Ref	1.3Ref	1.3Ref	4.3Ref	1.7Ref	1000

2. Part Number Code

APD 03 H 20 N 1R5
 A B C D E F

A: Series Name Power Inductors
 B: Dimensions(mm) 03: 3.2x3.2
 C: Materials NO use
 D: Thickness(mm) 20: 2.0 Max
 E: Tolerance N: ±30%
 F: Inductance 1R5=1.5uH

3. Electrical Characteristics

Part Number	Inductance (uH)	Test Frequency (KHz)	DC Resistance (mΩ)Max.	Saturation Current (A)Max.
APD03H20N1R5	1.5	100KHz/0.25V	48.0	2.1

Notes:

- 1) AEC-Q200 qualified.
- 2) All test data is referenced to 25°C ambient.
- 3) Operating temperature range -40°C to +125°C.
- 4) DC current(A) that will cause Lo to drop approximately 35%.
- 5) The part temperature(ambient + temp rise)should not exceed 125°C under worst case operating conditions. Circuit design,component placement, PWB trace size and thickness,airflow and other cooling provisions all affect the part temperature, Part temperature should be verified in the end application.

4. Test Data

ELECTRICAL CHARACTERISTIC				MECHANICAL DIMENSIONS			
SPEC	L(uH)	DCR(mΩ)	Isat(uH)	A(mm)	B(mm)	C(mm)	D(mm)
TOL	1.5	48.0	2.1A	3.2	3.2	2.0	4.2
NO	±30%	Max	(L0A-L2.1A) /L0A≤35%	Max	Max	Max	Max
1	1.52	37.2	1.23	2.97	3.01	1.89	OK
2	1.53	39.5	1.25	3.01	2.97	1.91	OK
3	1.37	36.3	1.14	3.03	3.02	1.89	OK
4	1.43	35.1	1.20	3.05	3.01	1.90	OK
5	1.54	34.3	1.26	3.04	3.04	1.92	OK
6	1.37	35.2	1.13	2.97	3.06	1.94	OK
7	1.38	34.3	1.16	3.01	3.04	1.87	OK
8	1.35	35.7	1.14	3.03	3.01	1.89	OK
9	1.39	36.7	1.17	3.05	3.03	1.91	OK
10	1.44	32.3	1.22	2.98	3.05	1.95	OK

Test Equipments: IM3536,VR126,VR7210,Calipers

5. Test and Measurement Procedures

5.1 Test Conditions

5.1.1 Unless otherwise specified, the standard atmospheric conditions for measurement/test as:

- Ambient Temperature: 20±15℃
- Relative Humidity: 65%±20%
- Air Pressure: 86KPa to 106KPa

5.1.2 If any doubt on the results, measurements/tests should be made within the following limits:

- Ambient Temperature: 20±2℃
- Relative Humidity: 65%±5%
- Air Pressure: 86KPa to 106Kpa

5.2 Visual Examination

- Inspection Equipment: 10X magnifier

5.3 Electrical Test

5.3.1 Inductance (L)

- Refer to the third item.
- Test equipment: IM3536 LCR meter or equivalent.
- Test Frequency and Voltage: Refer to the third item.

5.3.2 Direct Current Resistance (DCR)

- Refer to the third item.
- Test equipment: VR126 or equivalent.

5.3.3 Current

- Refer to the third item.
- Test equipment (see Fig.5.3.3-1): Electric Power, Electric current meter, Thermometer.

c. Measurement method (see Fig. 5.3.3-1):

1. Set test current to be 0 mA.
2. Measure initial temperature of chip surface.
3. Gradually increase voltage and measure chip temperature for corresponding current.

d. Definition of Temperature rise current: DC current that causes the temperature rise ($\Delta T = 40^\circ\text{C}$) from 20°C ambient (see Fig. 5.3.3-2).

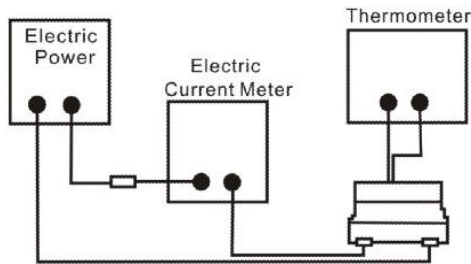

Fig.5.3.3-1

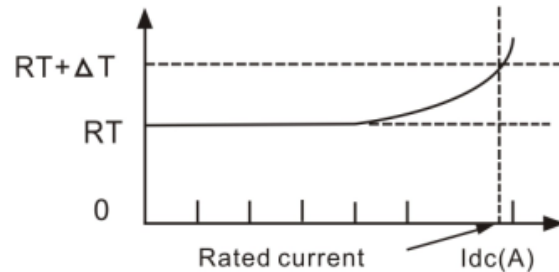
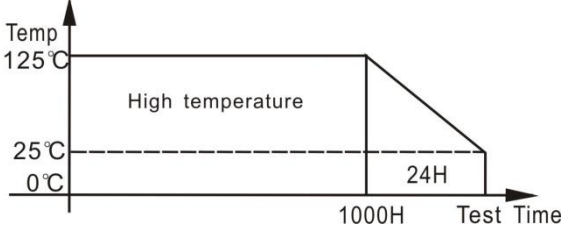
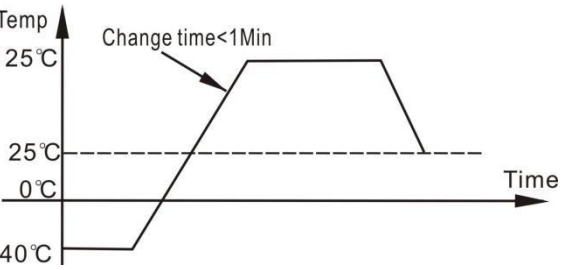
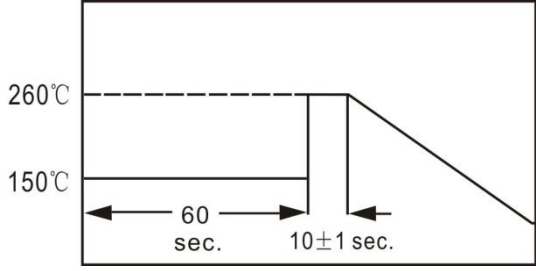
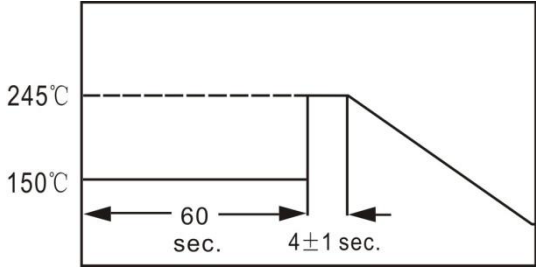

Fig.5.3.3-2

5.4 Reliability Test

Item	Specifications	Test conditions
5.4.1 High temperature storage test	No visible mechanical damage. Inductance change: Within $\pm 10\%$.	Temperature: $125 \pm 2^\circ\text{C}$. Duration: 1000hrs. Measured at room temperature after placing for 24 ± 4 hrs. 
5.4.2 Temperature cycling test	No visible mechanical damage. Inductance change: Within $\pm 10\%$.	Condition for 1 cycle. Step1: $-40 \pm 2^\circ\text{C}$ 30min Min. Step2: $125 \pm 2^\circ\text{C}$, transition time 1min Max. Step3: $125 \pm 2^\circ\text{C}$ 30min Min. Step4: Low temp, transition time 1min Max. Number of cycles: 1000. Measured at room temperature after placing for 24 ± 4 hrs. 
5.4.3 Biased humidity test	No visible mechanical damage. Inductance change: Within $\pm 10\%$.	Humidity : $85\% \pm 3$ RH. Temperature: $85^\circ\text{C} \pm 2^\circ\text{C}$. Duration : 1000hrs. Measured at room temperature after placing for 24 ± 4 hrs.

Item	Specifications	Test conditions
5.4.4 Operational life test	No visible mechanical damage. Inductance change: Within $\pm 10\%$.	Temperature: $105 \pm 2^\circ\text{C}$. Duration :1000hrs. Measured at room temperature after placing for 24 ± 4 hrs.
5.4.5 Resistance to solvent test	No visible mechanical damage. Inductance change: Within $\pm 10\%$.	Add aqueous wash chemical - OKEM clean or equivalent.
5.4.6 Vibration test	No visible mechanical damage. Inductance change: Within $\pm 10\%$.	Oscillation Frequency: $10 \sim 2\text{K} \sim 10\text{Hz}$ for 20 minute. Total Amplitude: $1.52\text{mm} \pm 10\%$. Testing Time : 12 hours(20 minutes, 12 cycles each of 3 orientations).
5.4.7 Resistance to soldering heat test	No visible mechanical damage. Inductance change: Within $\pm 10\%$.	Temperature ($^\circ\text{C}$): 260 ± 5 (solder temp). Time (s): 10 ± 1 . ramp/immersion and emersion rate: $25\text{mm/s} \pm 6 \text{ mm/s}$. Number of heat cycles:1. 
5.4.8 Solderability test	More than 95% of the terminal electrode should be covered with solder.	Steam Aging: 8 hours \pm 15 min. Preheat: 150°C , 60sec. Solder: Sn99.5%-Cu0. 5%. Temperature: $245 \pm 5^\circ\text{C}$. Flux for lead free: Rosin. 9.5%. Dip time: 4 ± 1 sec. Depth: completely cover the termination. 
5.4.9 Terminal strength (SMD) test	No visible mechanical damage.	With the component mounted on a PCB with the device to be tested, apply a 17.7 N (1.8 Kg) force to the side of a device being tested. This force shall be applied for 60 ± 1 seconds. Also the force shall be applied radually as not to apply a shock to the component being tested.

6. Packaging, Storage

6.1 Tape and Reel Packaging Dimensions

6.1 .1 Taping Dimensions (Unit: mm)

Please refer to Fig. 6.1.1-1

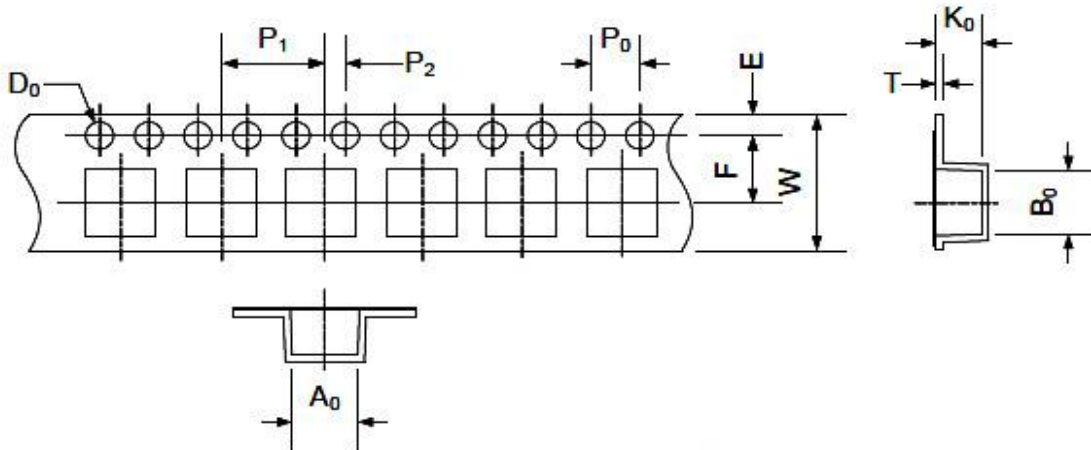

6.1.1-1

TYPE	A0	B0	W	E	F	P0	P1	P2	T	K0
APD03H20	3.4±0.1	3.4±0.1	12.0±0.3	1.75±0.1	5.5±0.1	4.0±0.1	8.0±0.1	2.0±0.1	0.4±0.1	2.2±0.1

6.1.2 Reel Dimensions (Unit: mm)

Please refer to Fig. 6.1.2-1.

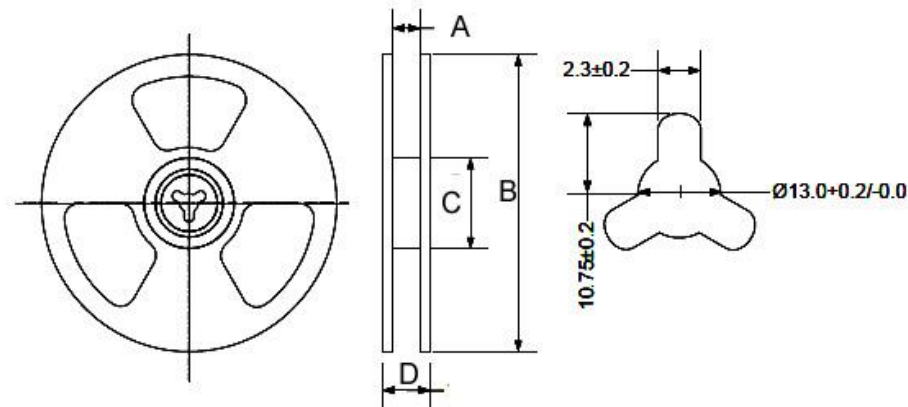

Fig. 6.1.2-1.

TYPE	A	B	C	D
APD03H20	12.5±2.0	330±2.0	100±2.0	16.5±2.0

6.2 Packaging

6.2.1 The inner box specification: 350*340*40MM

Packing quantity: 2000PCS/ box

Bubble bag : 37*45CM

Job description: putting the air bubble bag products placed inside the box, sealed with scotch tape

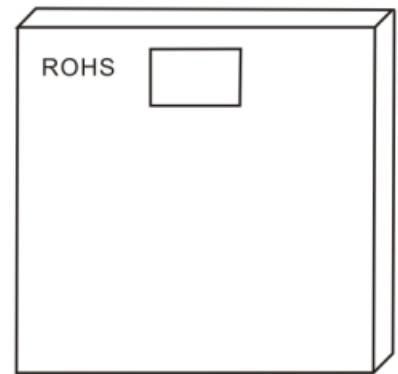

6.2.2 the outside box specification: 370*360*255MM

Packing quantity: 10000PCS/ box

Job description: will be outside the box bottom sealed, inner box into the box.

- a. with transparent tape sealed box at the top
- b. the specified location with a box labels in the outer box.
- c. if the mantissa box under a FCL with inner box or filling full

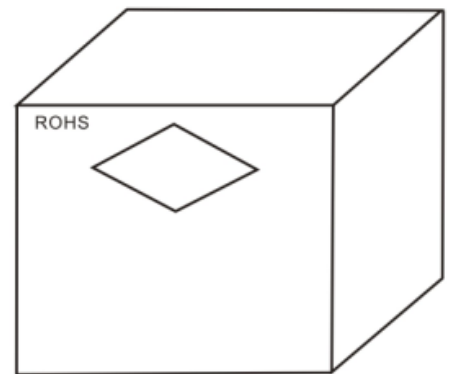

6.3 Storage

- a. To maintain the solderability of terminal electrodes and to keep the packing material in good condition, temperature and humidity in the storage area should be controlled.
- b. Recommended conditions: -10°C~40°C, 70%RH (Max.)
- c. The ambient temperature must be kept below 30°C. Even under ideal storage conditions, solderability of products electrodes may decrease as time passes. For this reason, product should be used with one year from the time of delivery.
- d. In case of storage over 6 months, solderability shall be checked before actual usage.

7. Recommended Soldering Technologies

7.1 Re-flowing Profile:

- △ Preheat condition: 150~200°C/60~120sec.
- △ Allowed time above 217°C: 60~90sec.
- △ Max temp: 260°C
- △ Max time at max temp: 5sec.
- △ Solder paste: Sn/3.0Ag/0.5Cu
- △ Allowed Reflow time: 2x max

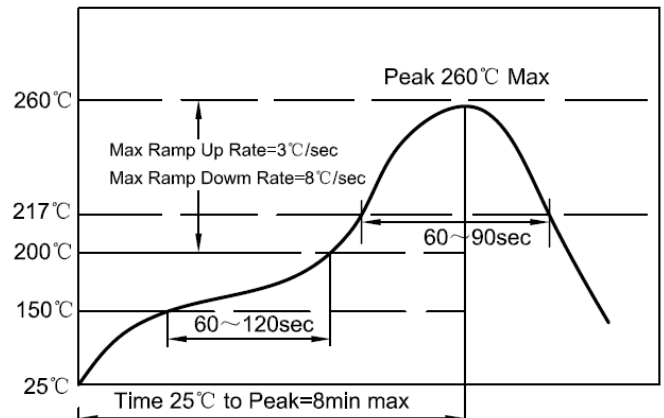

7.2 Iron Soldering Profile:

- △ Iron soldering power: Max.30W
 - △ Pre-heating: 150°C/60sec.
 - △ Soldering Tip temperature: 350°C Max.
 - △ Soldering time: 3sec Max.
 - △ Solder paste: Sn/3.0Ag/0.5Cu
 - △ Max.1 times for iron soldering
- [Note: Take care not to apply the tip of the soldering iron to the]

