

To : Q.Z TORCH INTERNATIONAL LIMITED-MOTO

## PRODUCT SPECIFICATION

P/N:                   JDK105ABJ475MV-F  
Type:                   Multilayer Ceramic Capacitors  
                          (High dielectric type)  
  
Soldering:            Reflow only  
  
Issue date:           July 2, 2018

Applicable products to RoHS restriction

Document No.  MLRME1800121	Specifications Multilayer Ceramic Capacitor (High dielectric type)
----------------------------------	--

1. Scope

This specification covers multilayer chip type ceramic capacitor (Pb-Free) for use (for reflow soldering) in electronic appliances and electric communications equipment.

2. Part Numbering System

Part number is indicated as follows.

(Example):       J    DK   105    A     BJ    475    M     V    -F   
                   ①   ※    ②       ③    ④   Capacitance   ⑤       ⑥       ⑦

※Voltage in high temperature loading test.(100%)

①Rated voltage

Code	Voltage [VDC]
J	6.3

②Size

Code	L×W [mm]
105	1.0×0.5

③Control Code

Per Fig 1

④Temperature characteristics

Characteristic	Capacitance change rate [%]	Temperature range [°C]	Reference temperature [°C]
BJ (X5R)	±15 (EIA)	-55 to +85	25

⑤Tolerance

Code	Tolerance
M	±20%

⑥Thickness

Code	Thickness [mm]
V	0.5

⑦Packaging

Code	Packaging type
- F	Taping

## Multilayer Ceramic Chip Capacitor

### 3. Test Conditions

Standard test conditions shall be temperature of 5 to 35°C, relative humidity of 45 to 85% and air pressure of 86 to 106kPa. Tests shall be conducted at temperature of 25±3°C, relative humidity of 60 to 70% and air pressure of 86 to 106kPa if test results are suspicious.

Unless otherwise specified, all tests shall be conducted under the standard test conditions.

### 4. Construction, Dimensions and Performance

Details of construction, dimensions and performance shall be specified in the following pages.

### 5. Packaging

Capacitors shall be packaged properly to avoid damage in the capacitors during transportation and storage.

The package shall be marked with part number, quantity, lot number, and manufacturer's name at its appropriate position.

### 6. Manufacturing site

TAIYO YUDEN CO., LTD. (JAPAN)

TAIYO YUDEN (SARAWAK) SDN, BHD. (MALAYSIA)

TAIYO YUDEN (GUANG DONG) CO., LTD. (CHINA)

TAIYO YUDEN (PHILIPPINES), INC. (PHILIPPINES)

### 7. Precautions

- This specification does not cover capacitors when Sn-Zn lead free solder is used.
- If you need further information, please contact us.
- When MLCCs are used in places where dew condensation develops and/or where corrosive gas such as hydrogen sulfide, sulfurous acid, or chlorine exists in the air, insulation (dielectric) deterioration may occur. Please do not use MLCCs under such environmental conditions.

### 8. Storage conditions

- Temperature and humidity in storage area shall be controlled carefully to maintain the solderability of terminal electrodes and to keep the packaging material in good condition. Humidity should especially be kept as low as possible.
- Recommended conditions  
Ambient temperature: 30°C or below  
Humidity: 70% RH or below  
The ambient temperature must be kept below +40°C. Even under ideal storage conditions, capacitor electrode solderability decreases with time. Therefore ceramic chip capacitors should be used 6 months from the time of delivery. If the period is exceeded, please check solderability before using the capacitors.
- The packaging material should be kept where no chlorine or sulfur exists in the air.

## Multilayer Ceramic Chip Capacitor

### 9. RoHS compliance

- Our products conform to RoHS.
- "RoHS compliance" means that the product does not contain lead, cadmium, mercury, hexavalent chromium, PBB or PBDE referring to EU Directive 2011/65/EU, except other non-restricted substances or impurities which cannot be technically removed at refining process.
- Our products are halogen-free products.

### 10. Others

#### Resin-coating:

- Coating/molding capacitors with resin may have negative effects on the capacitor functions.
- When capacitors are coated/molded with resin, please check effects on the capacitors by analyzing them in actual applications prior to use.

No.	Item	Specified Value	Remarks				
1	Operating Temperature Range	Capable of continuous operation under these conditions.	-55 to +85°C				
2	Shape and Dimensions	Per Fig.1					
3	Heat Treatment		Initial value shall be measured after test sample is heat-treated at 150 +0/-10°C for an hour and kept at room temperature for 24±2 hours.				
4	Voltage Treatment		Initial value shall be measured after test sample is voltage-treated for an hour at temperature and voltage which are specified as test conditions, and kept at room temperature for 24±2 hours.				
5	Dielectric Withstanding Voltage (between terminals)	No abnormality.	Conforming to EIA RS-198 (1991). 160% of DC rated voltage shall be applied for 1 to 5 seconds. Charging and discharging current shall be 50mA or less.				
6	Insulation Resistance (IR)	100MΩ·μF Min	Conforming to EIA RS-198 (1991). Rated voltage shall be applied to test sample for 1 minute±5 seconds. Charging and discharging current shall be 50mA or less.				
7	Capacitance (Cap.)	4.7 μF	Conforming to EIA RS-198 (1991). Heat treatment specified in this specification shall be conducted prior to measurement. Measuring frequency and voltage shall conform to the table below. <table border="1" data-bbox="896 1133 1305 1234"> <thead> <tr> <th>Measuring Frequency</th> <th>Measuring Voltage</th> </tr> </thead> <tbody> <tr> <td>1kHz±10%</td> <td>0.5±0.1Vrms</td> </tr> </tbody> </table>	Measuring Frequency	Measuring Voltage	1kHz±10%	0.5±0.1Vrms
Measuring Frequency	Measuring Voltage						
1kHz±10%	0.5±0.1Vrms						
8	Dissipation Factor (DF)	10.0% Max.	Conforming to EIA RS-198 (1991). Heat treatment specified in this specification shall be conducted prior to measurement. Measuring frequency and voltage shall conform to the table below. <table border="1" data-bbox="896 1458 1305 1559"> <thead> <tr> <th>Measuring Frequency</th> <th>Measuring Voltage</th> </tr> </thead> <tbody> <tr> <td>1kHz±10%</td> <td>0.5±0.1Vrms</td> </tr> </tbody> </table>	Measuring Frequency	Measuring Voltage	1kHz±10%	0.5±0.1Vrms
Measuring Frequency	Measuring Voltage						
1kHz±10%	0.5±0.1Vrms						
9	Temperature Characteristic	Per P.1④	Conforming to EIA RS-198 (1991). Heat treatment specified in this specification shall be conducted prior to measurement. Maximum capacitance deviation in both (+) and (-) sides in range of lowest temperature to highest temperature for capacitor shall be indicated in ratio of variation in reference to capacitance value at reference temperature.				

No.	Item	Specified Value	Remarks
10	Adhesive Force of Terminal Electrodes	Terminal electrodes shall be no exfoliation or a sign of exfoliation.	Conforming to EIA RS-198 (1991). Test sample shall be soldered to test board shown in Fig.2 and a force of 5N{0.51kgf} shall be applied in vertically downward direction for 30±5 seconds.
11	Vibration	Initial performance shall be satisfied.	Conforming to EIA RS-198 (1991). Test sample shall be soldered to test board shown in Fig.2. Heat treatment specified in this specification shall be conducted prior to test.  Test conditions: Frequency range: 10-55Hz Overall amplitude: 1.5mm Sweeping method: 10-55-10Hz for 1 min. Each two hours in X,Y,Z direction: 6 hours in total
12	Solderability	More than 95% of terminal electrode shall be covered with fresh solder.	<p><b>【Eutectic】</b> Solder used shall be [JIS Z 3282 H60A or H63A]. Test sample shall be completely submerged in molten solder at 230±5°C for 4±1 seconds.</p> <p><b>【Pb free】</b> Solder used shall be [Sn/3.0Ag/0.5Cu]. Test sample shall be completely submerged in molten solder at 245±3°C for 4±1 seconds.</p>

No.	Item	Specified Value	Remarks															
13	Resistance to Soldering Heat	Appearance	No abnormality															
		Cap. Change	±15.0%															
		DF	10.0% Max.															
		IR	Initial value shall be satisfied.															
		Dielectric Withstanding Voltage (between terminals)	No dielectric breakdown or damage															
<p>Conforming to EIA RS-198 (1991). Solder used shall be [JIS Z 3282 H60A or H63A]. Heat treatment specified in this specification shall be conducted prior to test.</p> <p>Test sample shall be completely submerged in molten solder of 270±5°C for 3±0.5seconds. Preheating as shown in the table below shall be continuously conducted before submersion and test sample shall be kept at ambient temperature after test.</p> <table border="1"> <thead> <tr> <th>Sequence</th> <th>Temperature (°C)</th> <th>Time (min.)</th> </tr> </thead> <tbody> <tr> <td>1</td> <td>80 to 100</td> <td>2 to 5</td> </tr> <tr> <td>2</td> <td>150 to 200</td> <td>2 to 5</td> </tr> </tbody> </table> <p>Measurement shall be conducted after test sample is kept at ambient temperature for 24±2 hours.</p>				Sequence	Temperature (°C)	Time (min.)	1	80 to 100	2 to 5	2	150 to 200	2 to 5						
Sequence	Temperature (°C)	Time (min.)																
1	80 to 100	2 to 5																
2	150 to 200	2 to 5																
14	Thermal Shock	Appearance	No abnormality															
		Cap. Change	±15.0%															
		DF	10.0% Max.															
		IR	Initial value shall be satisfied.															
		Dielectric Withstanding Voltage (between terminals)	No dielectric breakdown or damage															
<p>Conforming to EIA RS-198 (1991). Test sample shall be soldered to test board shown in Fig.2. Heat treatment specified in this specification shall be conducted prior to test.</p> <p>Test sample shall be exposed to each of temperature conditions in the following Steps 1 to 4 in sequence for the specified time.</p> <table border="1"> <thead> <tr> <th>Step</th> <th>Temperature (°C)</th> <th>Time (min)</th> </tr> </thead> <tbody> <tr> <td>1</td> <td>Lowest operating temperature</td> <td>30±3</td> </tr> <tr> <td>2</td> <td>Ambient temperature</td> <td>2 to 3</td> </tr> <tr> <td>3</td> <td>Highest operating temperature</td> <td>30±3</td> </tr> <tr> <td>4</td> <td>Ambient temperature</td> <td>2 to 3</td> </tr> </tbody> </table> <p>Temperature cycle shall be repeated five times in this method, and measurement shall be conducted after test sample is kept at ambient temperature for 24±2 hours.</p>				Step	Temperature (°C)	Time (min)	1	Lowest operating temperature	30±3	2	Ambient temperature	2 to 3	3	Highest operating temperature	30±3	4	Ambient temperature	2 to 3
Step	Temperature (°C)	Time (min)																
1	Lowest operating temperature	30±3																
2	Ambient temperature	2 to 3																
3	Highest operating temperature	30±3																
4	Ambient temperature	2 to 3																

No.	Item	Specified Value	Remarks	
15	Humidity (Steady State)	Appearance	No abnormality	Conforming to EIA RS-198 (1991). Heat treatment specified in this specification shall be conducted prior to test. Test sample shall be put into constant temperature/humidity bath at 40±2°C and 90 to 95%RH for 500+24/-0 hours. Measurement shall be conducted after test sample is kept at ambient temperature for the 24±2 hours.
		Cap. Change	±25.0%	
		DF	15.0% Max.	
		IR	10MΩ·μF Min.	
16	High Temperature Loading	Appearance	No abnormality	Conforming to EIA RS-198 (1991). Voltage treatment specified in this specification shall be conducted prior to test. Test sample shall be put in thermostatic oven at maximum operating temperature and 100 % of DC voltage shall be continuously applied for 1000+48/-0 hours. Charging and discharging current shall be 50mA or less. Measurement shall be conducted after test sample is kept at ambient temperature for 24±2 hours.
		Cap. Change	±25.0%	
		DF	15.0% Max.	
		IR	10MΩ·μF Min.	
17	Humidity Loading	Appearance	No abnormality	Conforming to EIA RS-198 (1991). Voltage treatment specified in this specification shall be conducted prior to test. Test sample shall be put into constant temperature/humidity bath at 40±2°C and 90 to 95%RH, and DC rated voltage shall be continuously applied for 500 +24/-0 hours. Charging and discharging current shall be 50mA or less. Measurement shall be conducted after test sample is kept at ambient temperature for 24±2 hours.
		Cap. Change	±25.0%	
		DF	15.0% Max.	
		IR	5MΩ·μF Min.	
18	Bending Strength	Appearance	No abnormality	Test sample shall be soldered to test board as shown in Fig.3. Sample shall be carefully soldered to avoid abnormality such as heat shock. The board is bent 1.0mm for 10 seconds as shown in Fig.4. Measurement shall be conducted as the board is bent 1.0mm.
		Cap. Change	±12.5%	



Fig 1: Shape and Dimensions

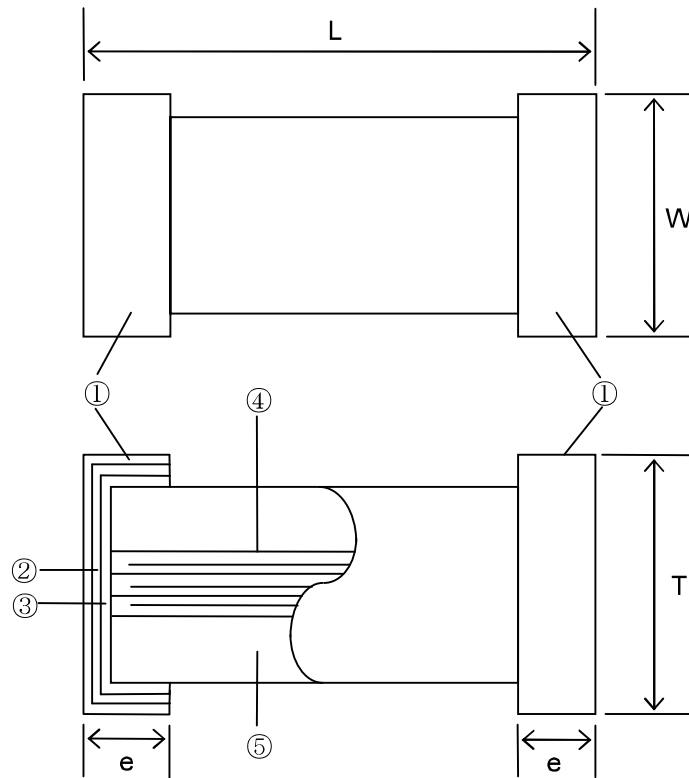

[High dielectric type]

No.	Name	Material
①	Terminal Electrodes (Surface)	Sn Plating
②	Terminal Electrodes	Ni Plating
		Cu Plating
③	External Electrodes	Ni
④	Internal Electrodes	Ni
⑤	Dielectric	Barium titanate

Item type	Control Code	Dimension [Unit: mm]			
		L	W	T	e
105	A	$1.0 \pm 0.10$	$0.5 \pm 0.10$	$0.5 \pm 0.10$	$0.25 \pm 0.10$

Fig.2 Board / Test Jig of Adhesive force of Terminal Electrodes, Vibration and Thermal Shock

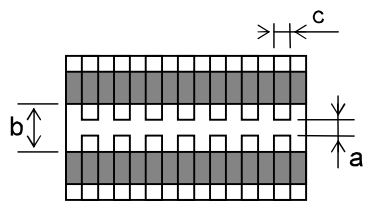

Size (L×W)	a	b	c
1.0×0.5	0.4	1.5	0.5

[Unit: mm]

Material: Glass epoxy board [JIS C 6484]

- Copper foil (thickness: 0.035mm)
- Solder resist

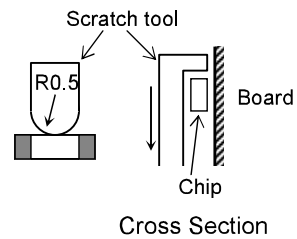

Remarks: Uniform soldering shall be conducted with solder (H60A or H63A in JIS Z 3282) by using soldering iron or soldering oven.  
Soldering shall be conducted with care to avoid abnormality such as heat shock.

Fig.3 Test Board

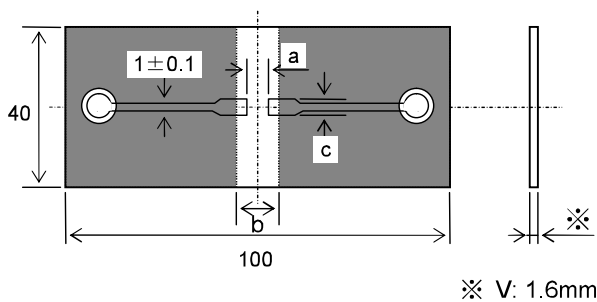

Material: Glass epoxy board [JIS C 6484]

- Copper foil (thickness: 0.035mm)
- Solder resist

Size (L×W)	a	b	c
1.0×0.5	0.4	1.5	0.5

[Unit: mm]

Fig.4

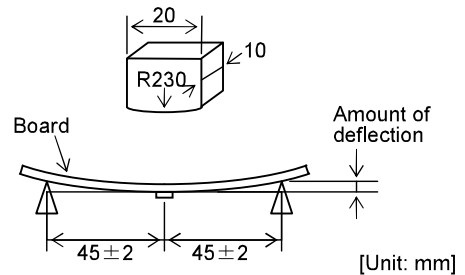

Apply pressure at the rate of 0.5mm/sec. until amount of deflection reaches to 1.0mm.

# Tape Packaging 105 Type

◎ Tape packaging type (products with thickness code V): Paper tape

Dimensions [Unit: mm]

A ※1	B ※1
0.65±0.1	1.15±0.1
0.7±0.1 ※2	1.2±0.1 ※2
0.74±0.08 ※3	1.34±0.08 ※3
0.8±0.1 ※4	1.4±0.1 ※4

Dimensions [Unit: mm]

C	D	E	F	G	H	J	t ※1
8.0±0.3	3.5±0.05	1.75±0.1	2.0±0.05	2.0±0.05	4.0±0.1	$\phi 1.5 \begin{matrix} +0.1 \\ -0 \end{matrix}$	0.8max.
							0.85max. ※4

- ※1: A, B, t: Sufficient clearance
- ※2: \*MK105A\*\*\*\*\*V\*\* / JDK105ABJ475MV-F
- ※3: \*MK105B\*\*\*\*\*V\*\*
- ※4: \*MK105C\*\*\*\*\*V\*\*

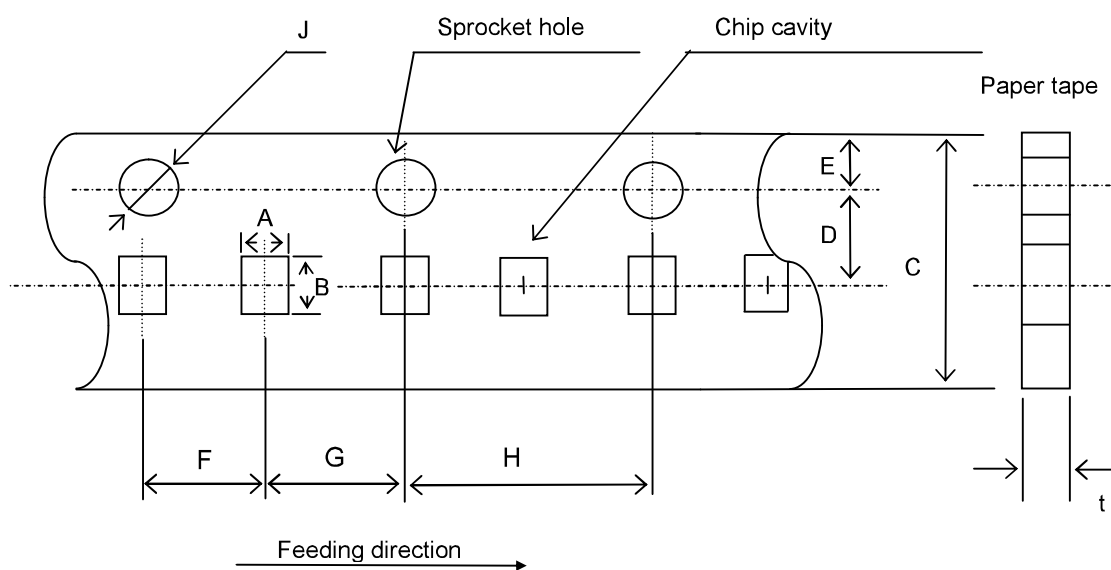

# Tape Packaging 105 Type

Dimensions of Reel [Unit: mm]

A	B	C	D	E	W	t	R
$\phi 178 \pm 2.0$	$\phi 50 \text{min.}$	$\phi 13.0 \pm 0.2$	$\phi 21.0 \pm 0.8$	$2.0 \pm 0.5$	$10.0 \pm 1.5$	2.5max.	1.0

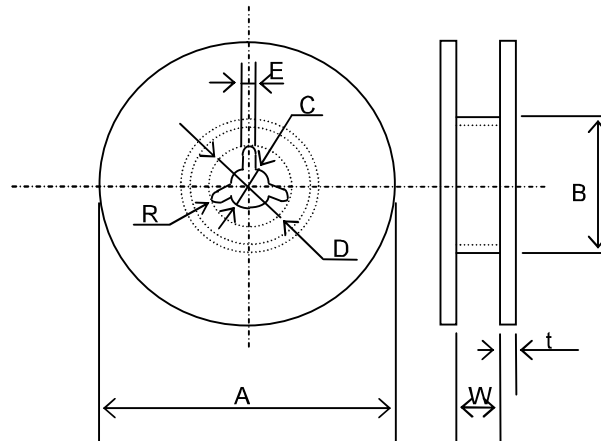

## Tape Packaging (thickness code V)

1. Taping shall be right-sided wound. Sprocket hole shall be on the right side against the pull-out direction.
2. Either the width side (W) or the thickness side (T) of the components faces up at random when the components are inserted in the chip cavities.
3. There shall be blank spaces in each reel tape as shown in the following figure.
  - Leader part 400mm min.
  - Leader part (Blank part) 100mm min.
  - Trailer (Blank part) 160mm min.

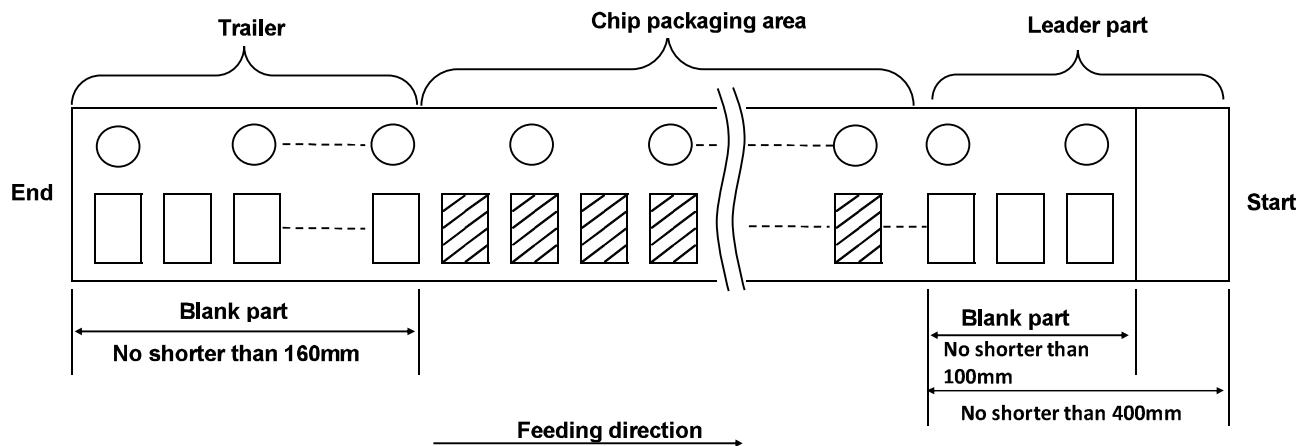

4. Top tape and bottom tape (only thickness rank V) of paper taping shall not be crossed over sprocket holes.
5. Paper tape shall not be seamed.
6. Tensile strength of the tape is 5N (0.51kgf) or over.
7. The number of the chip missing from tape reel shall be 1 piece at a maximum per reel.
8. The number of packaged chips per reel is shown in the table below.
9. Label indicating part No., quantity and control No. shall be attached to the outside of reel.
10. Peeling strength of top tape shall be 0.1 to 0.7N (10.2 to 71.4gf) when top tape is peeled from carrier tape at an angle of  $0^\circ$  to  $20^\circ$ .

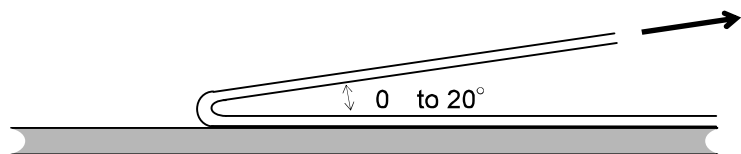

### Dimensions of reel

Thickness [Unit: mm] (Thickness code)	Quantity (pcs/reel)	Carrier tape
0.5 (V)	10,000	Paper

# Tape Packaging 105 Type

[Packaging Mode]

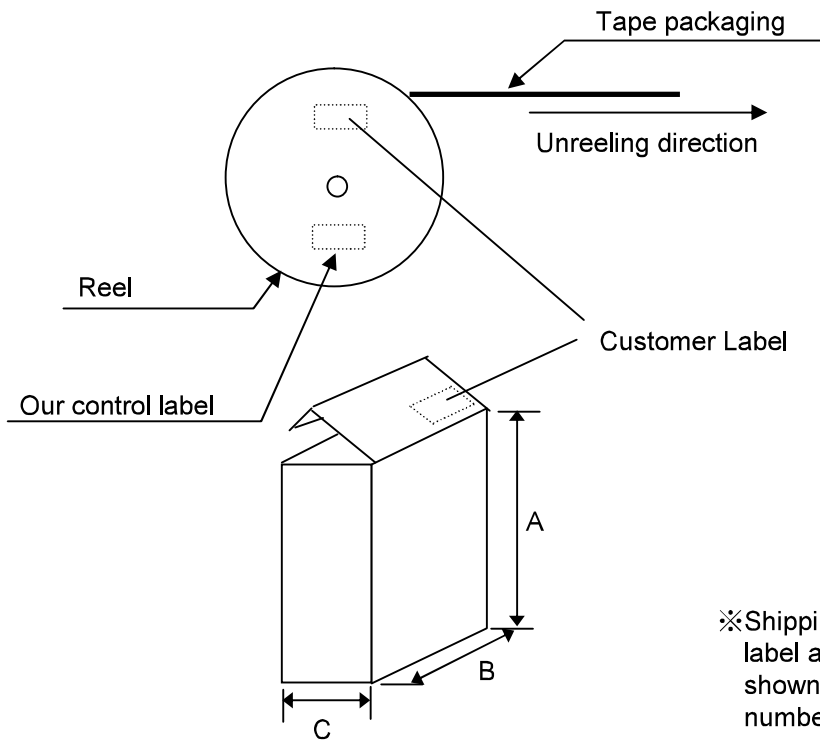

- Customer Label contents
1. Manufacture Name
  2. Customer Parts No.
  3. Our parts no.
  4. Quantity
  5. Control No.  
(Shipping lot number) ※
  6. Manufacturing site  
MADE IN ○○○
  7. RoHS

※Shipping lot number is marked on our control label and is also traceable from Control number shown in customer label; no shipping lot number is marked on customer label.

Code	A	B	C	reel
Size	190	185	70	5 reels max
			140	10 reels max

[Unit: mm]

Material: Paper

(The size is only for reference.)

Note: Labels are attached on reels/boxes only after components passed all inspections.

Labeled products: Acceptance components

## Composition of the shipping lot number

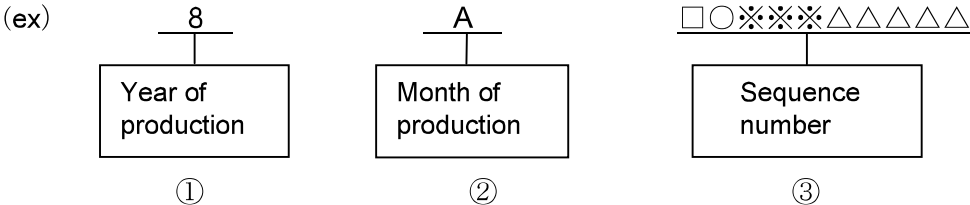

- ① First digit of lot No.: Production year (Last number of the Christian era)  
Example: 2018year → 8
- ② Second digit of lot No.: Month of production (See the table below.)
- ③ Sequence number of lot No.: Alphanumeric characters including space

Month	1	2	3	4	5	6	7	8	9	10	11	12
Code	A	B	C	D	E	F	G	H	J	K	L	M

## Recommended Soldering Profiles for Lead-free Solder Paste

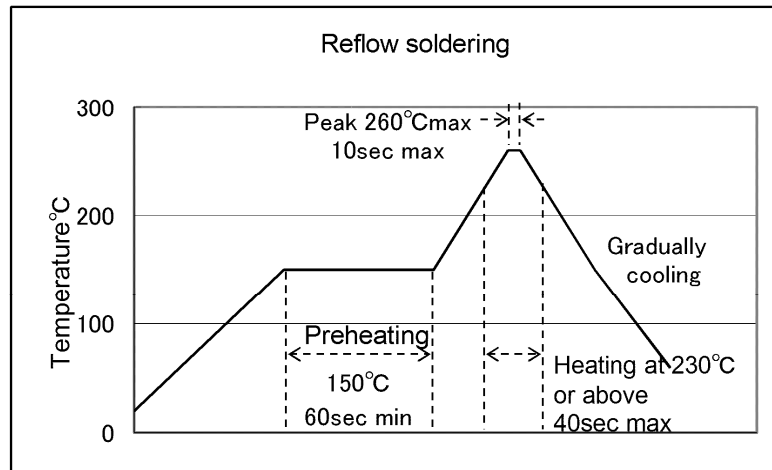

\*Ceramic chip component should be preheated sufficiently to maintain the temperature difference between the component surface and solder at 130°C or below.

\*Allowable number of reflow soldering: **2 times max.**

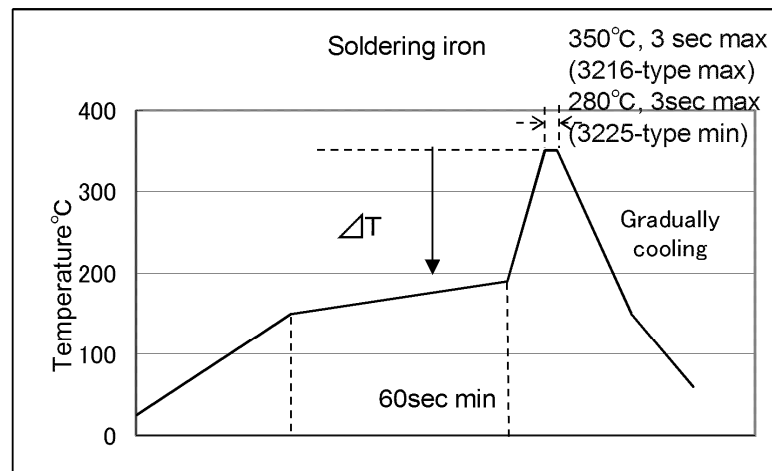

\*  $\Delta T \leq 150^\circ\text{C}$  (3216-type max),  $\Delta T \leq 130^\circ\text{C}$  (3225-type min)

\*Preheating control: Boards and components should be preheated sufficiently at 150°C or over, and soldering should be conducted with soldering iron as boards and components are maintained at sufficient temperatures.

\*The soldering iron should not directly touch the components.

\*Allowable number of hand soldering: **1 time max.**

\*Recommendation: Use 20W-soldering iron with the 1φ-tip or less.

Temperature in usage of Pb-free solder (Sn-3Ag-0.5Cu)

Case size	Soldering iron tip temp	Preheating temp.
3216-type max.	$\leq 350^\circ\text{C}$	$\geq 150^\circ\text{C}$
3225-type min.	$\leq 280^\circ\text{C}$	$\geq 150^\circ\text{C}$

\*\*Note: The above profiles are the maximum allowable soldering condition; therefore, these profiles are not always recommended.



Operating conditions for guarantee of products are as shown in the specification.  
Please note that TAIYO YUDEN CO., LTD. shall not be responsible for a failure and/or abnormality which are caused by use under the conditions other than aforesaid operating conditions.

- Please conduct validation and verification of our products in actual condition of mounting and operating environment before using our products.
- The products listed in this specification are intended for use in general electronic equipment (e.g., AV equipment, OA equipment, home electric appliances, office equipment, information and communication equipment including, without limitation, mobile phone, and PC) and medical equipment classified as Class I or II by IMDRF. Please be sure to contact TAIYO YUDEN for further information before using the products for any equipment which may directly cause loss of human life or bodily injury (e.g., transportation equipment including, without limitation, automotive powertrain control system, train control system, and ship control system, traffic signal equipment, disaster prevention equipment, medical equipment classified as Class III by IMDRF, highly public information network equipment including, without limitation, telephone exchange, and base station).

Please do not incorporate our products into any equipment requiring high levels of safety and/or reliability (e.g., aerospace equipment, aviation equipment\*, medical equipment classified as Class IV by IMDRF, nuclear control equipment, undersea equipment, military equipment).

\*Note: There is a possibility that our products can be used only for aviation equipment that does not directly affect the safe operation of aircraft (e.g., in-flight entertainment, cabin light, electric seat, cooking equipment) if such use meets requirements specified separately by TAIYO YUDEN. Please be sure to contact TAIYO YUDEN for further information before using our products for such aviation equipment.

When our products are used even for high safety and/or reliability-required devices or circuits of general electronic equipment, it is strongly recommended to perform a thorough safety evaluation prior to use of our products and to install a protection circuit as necessary.

Please note that unless you obtain prior written consent of TAIYO YUDEN, TAIYO YUDEN shall not be in any way responsible for any damages incurred by you or third parties arising from use of the products listed in this specification for any equipment requiring inquiry to TAIYO YUDEN or prohibited for use by TAIYO YUDEN as described above.

- Information contained in this specification is intended to convey examples of typical performances and/or applications of our products and is not intended to make any warranty with respect to the intellectual property rights or any other related rights of TAIYO YUDEN or any third parties nor grant any license under such rights.
- Please note that the scope of warranty for our products is limited to the delivered our products themselves and TAIYO YUDEN shall not be in any way responsible for any damages resulting from a fault or defect in our products. Notwithstanding the foregoing, if there is a written agreement (e.g., supply and purchase agreement, quality assurance agreement) signed by TAIYO YUDEN and your company, TAIYO YUDEN will warrant our products in accordance with such agreement.
- The contents of this specification are applicable to our products which are purchased from our sales offices or authorized distributors (hereinafter “TAIYO YUDEN’s official sales channel”). Please note that the contents of this specification are not applicable to our products purchased from any seller other than TAIYO YUDEN’s official sales channel.
- Caution for Export  
Some of our products listed in this specification may require specific procedures for export according to “U.S. Export Administration Regulations”, “Foreign Exchange and Foreign Trade Control Law” of Japan, and other applicable regulations. Should you have any questions on this matter, please contact our sales staff.