

## P-channel Enhanced mode SOP-8/DFN3\*3 MOSFET

### Features

- High ruggedness
- Low  $R_{DS(ON)}$  (Typ 14m $\Omega$ )@ $V_{GS}=-4.5V$   
Low  $R_{DS(ON)}$  (Typ 10m $\Omega$ )@ $V_{GS}=-10V$
- Low Gate Charge (Typ 48nC)
- Improved dv/dt Capability
- 100% Avalanche Tested
- Application: Adaptor Input Switch for Notebook PC

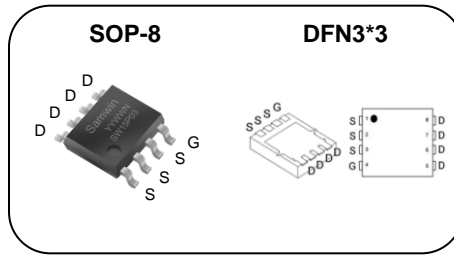

SOP-8/DFN3\*3: 4.Gate 5,6,7,8.Drain 1,2,3.Source

$BV_{DSS}$ : -30V
$I_D$ : -15A
$R_{DS(ON)}$ : 14m $\Omega$ @ $V_{GS}=-4.5V$ 10m $\Omega$ @ $V_{GS}=-10V$

### General Description

This power MOSFET is produced with advanced technology of SAMWIN. This technology enable the power MOSFET to have better characteristics, including Fast switching time, low on resistance, low gate charge and especially excellent Avalanche characteristics.



### Order Codes

Item	Sales Type	Marking	Package	Packaging
1	SW K 15P03	SW15P03	SOP-8	REEL
2	SW H 15P03	SW15P03	DFN3*3	REEL

### Absolute maximum ratings

Symbol	Parameter	Value		Unit
		SOP-8	DFN3*3	
$V_{DSS}$	Drain to source voltage	-30		V
$I_D$	Continuous drain current (@ $T_C=25^\circ C$ )	-15*		A
	Continuous drain current (@ $T_C=100^\circ C$ )	-9.5*		A
$I_{DM}$	Drain current pulsed (note 1)	-60		A
$V_{GS}$	Gate to source voltage	$\pm 25$		V
$E_{AS}$	Single pulsed avalanche energy (note 2)	81		mJ
dv/dt	Peak diode recovery dv/dt (note 3)	5		V/ns
$P_D$	Total power dissipation (@ $T_a=25^\circ C$ )	2.5	2.1	W
	Derating factor above 25 $^\circ C$	0.02	0.017	W/ $^\circ C$
$T_{STG}, T_J$	Operating junction temperature & storage temperature	-55 ~ + 150		$^\circ C$

\*. Drain current is limited by junction temperature.

### Thermal characteristics

Symbol	Parameter	Value		Unit
		SOP-8	DFN3*3	
$R_{thja}$	Thermal resistance, Junction to ambient (note)	50	60	$^\circ C/W$

Note:  $R_{thja}$  is the sum of the junction-to-case and case-to-ambient thermal resistance where the case thermal reference is defined as the solder mounting surface of the drain pins.  $R_{thjc}$  is guaranteed by design while  $R_{thca}$  is determined by the user's board design.



SOP-8 : 50 $^\circ C/W$  on a 1 in<sup>2</sup> pad of 2oz copper.  
DFN3\*3 : 60 $^\circ C/W$  on a 1 in<sup>2</sup> pad of 2oz copper.

Electrical characteristic (  $T_C = 25^\circ\text{C}$  unless otherwise specified )

Symbol	Parameter	Test conditions	Min.	Typ.	Max.	Unit
<b>Off characteristics</b>						
$BV_{DSS}$	Drain to source breakdown voltage	$V_{GS}=0V, I_D=-250\mu A$	-30			V
$\Delta BV_{DSS} / \Delta T_J$	Breakdown voltage temperature coefficient	$I_D=-250\mu A$ , referenced to $25^\circ\text{C}$		0.02		V/ $^\circ\text{C}$
$I_{DSS}$	Drain to source leakage current	$V_{DS}=-30V, V_{GS}=0V$			-1	$\mu A$
		$V_{DS}=-24V, T_C=125^\circ\text{C}$			-50	$\mu A$
$I_{GSS}$	Gate to source leakage current, forward	$V_{GS}=-25V, V_{DS}=0V$			-100	nA
	Gate to source leakage current, reverse	$V_{GS}=25V, V_{DS}=0V$			100	nA
<b>On characteristics</b>						
$V_{GS(TH)}$	Gate threshold voltage	$V_{DS}=V_{GS}, I_D=-250\mu A$	-1		-2.5	V
$R_{DS(ON)}$	Drain to source on state resistance	$V_{GS}=-4.5V, I_D=-7.5A$		14	22	m $\Omega$
		$V_{GS}=-10V, I_D=-7.5A$		10	14	m $\Omega$
$G_{fs}$	Forward transconductance	$V_{DS}=-10V, I_D=-7.5A$		29		S
<b>Dynamic characteristics</b>						
$C_{iss}$	Input capacitance	$V_{GS}=0V, V_{DS}=-15V, f=1\text{MHz}$		3290		pF
$C_{oss}$	Output capacitance			344		
$C_{riss}$	Reverse transfer capacitance			277		
$t_{d(on)}$	Turn on delay time	$V_{DS}=-15V, I_D=-15A, R_G=25\Omega, V_{GS}=-10V$ (note 4,5)		15		ns
$t_r$	Rising time			90		
$t_{d(off)}$	Turn off delay time			214		
$t_f$	Fall time			150		
$Q_g$	Total gate charge	$V_{DS}=-24V, V_{GS}=-10V, I_D=-15A$ (note 4,5)		48		nC
$Q_{gs}$	Gate-source charge			7		
$Q_{gd}$	Gate-drain charge			10		
$R_g$	Gate resistance	$V_{DS}=0V$ , Scan F mode		14		$\Omega$

### Source to drain diode ratings characteristics

Symbol	Parameter	Test conditions	Min.	Typ.	Max.	Unit
$I_S$	Continuous source current	Integral reverse p-n Junction diode in the MOSFET			-15	A
$I_{SM}$	Pulsed source current				-60	A
$V_{SD}$	Diode forward voltage drop.	$I_S=-15A, V_{GS}=0V$			-1.4	V
$t_{rr}$	Reverse recovery time	$I_S=-15A, V_{GS}=0V,$ $dI_F/dt=100A/\mu s$		17		ns
$Q_{rr}$	Reverse recovery charge			3.5		nC

※. Notes

1. Repetitive rating : pulse width limited by junction temperature.
2.  $L=4.5\text{mH}, I_{AS}=-6A, V_{DD}=-25V, R_G=25\Omega$ , Starting  $T_J=25^\circ\text{C}$
3.  $I_{SD} \leq -15A, di/dt = 100A/\mu s, V_{DD} \leq BV_{DSS}$ , Starting  $T_J=25^\circ\text{C}$
4. Pulse Test : Pulse Width  $\leq 300\mu s$ , duty cycle  $\leq 2\%$
5. Essentially independent of operating temperature.

**Fig. 1. On-state characteristics**

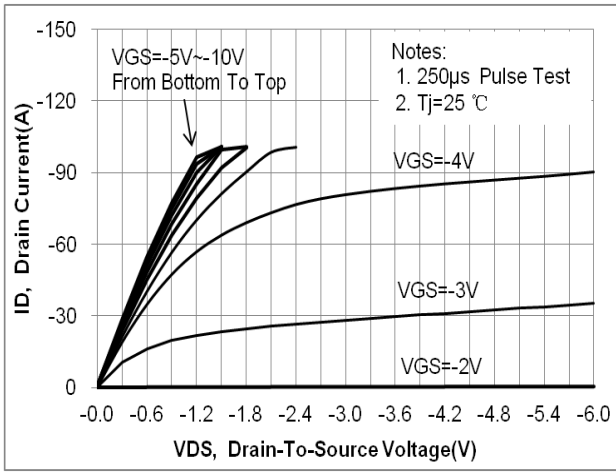

**Fig. 2. On-resistance variation vs. drain current and gate voltage**

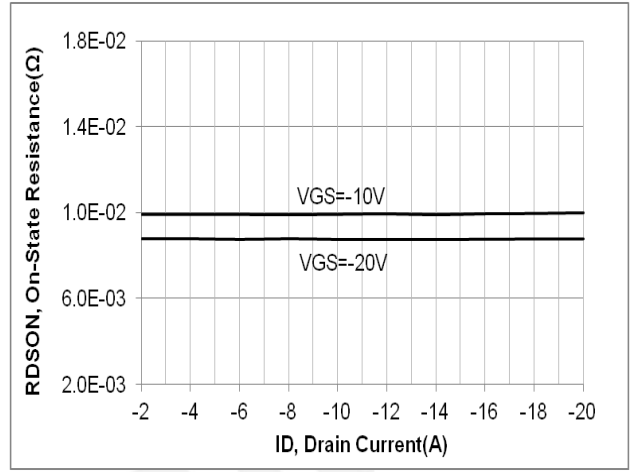

**Fig. 3. Gate charge characteristics**

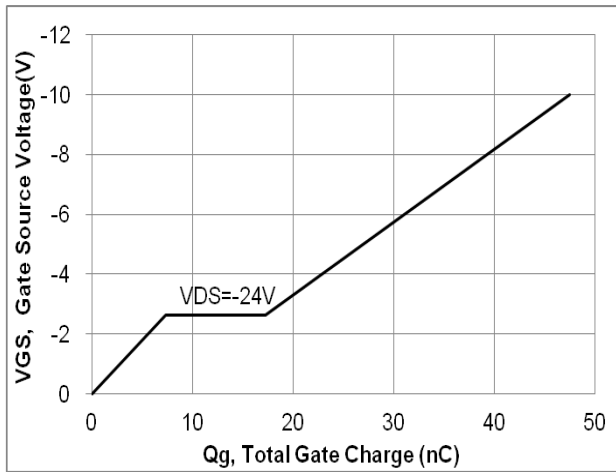

**Fig. 4. On state current vs. diode forward voltage**

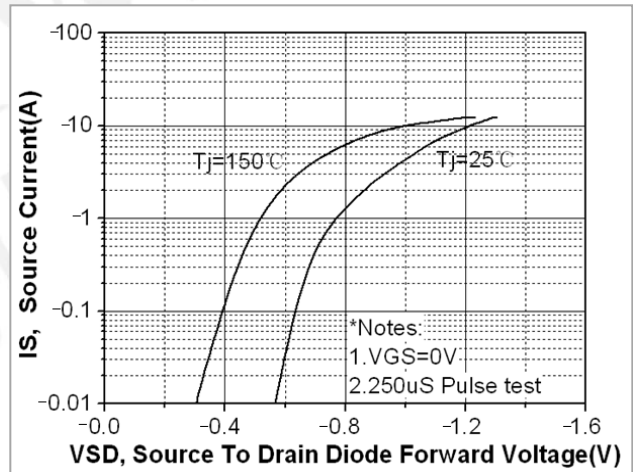

**Fig 5. Breakdown Voltage Variation vs. Junction Temperature**

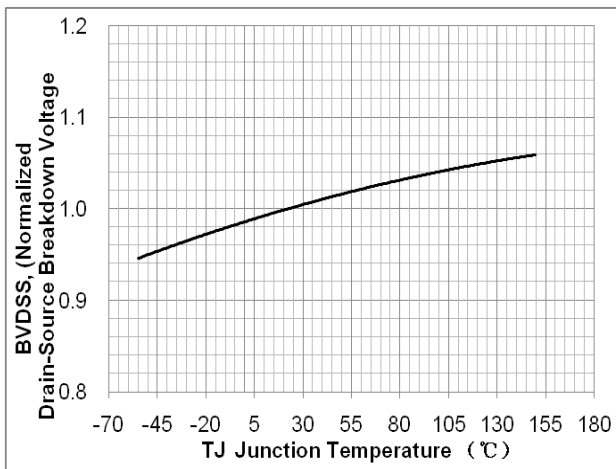

**Fig. 6. On resistance variation vs. junction temperature**

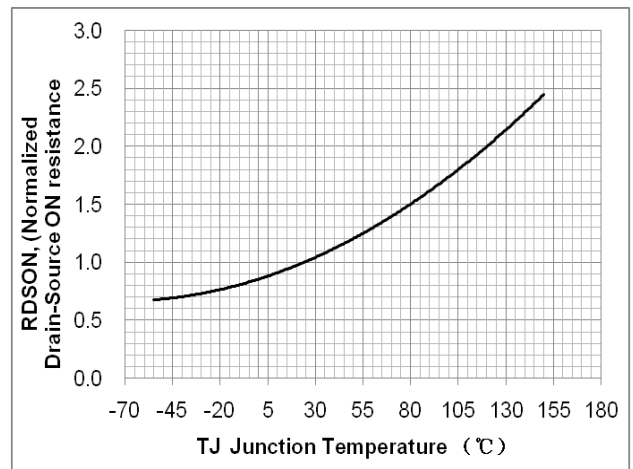

Fig. 7. Capacitance Characteristics

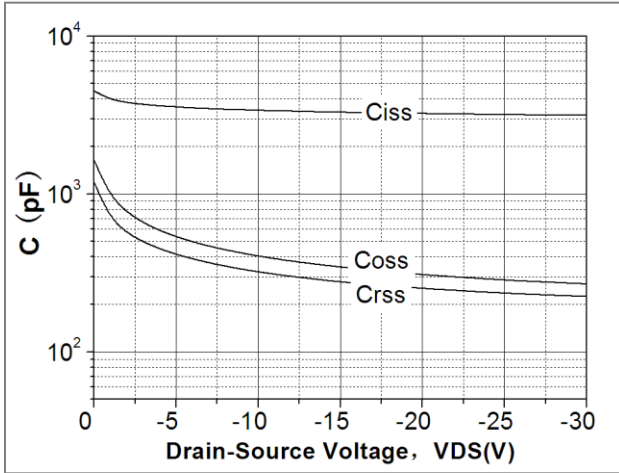

Fig. 8. Maximum safe operating area (SOP-8)

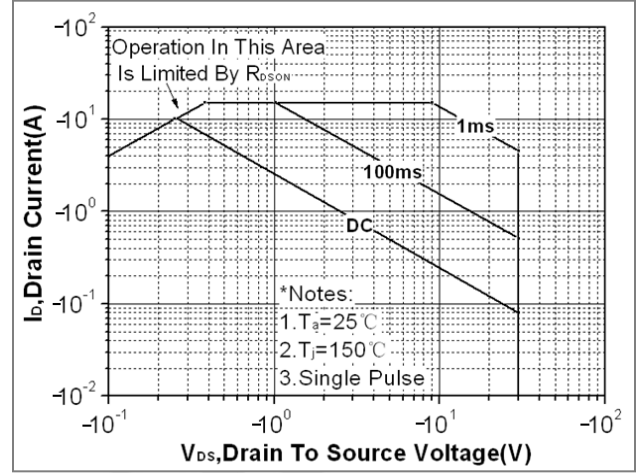

Fig. 9. Maximum safe operating area (DFN3\*3)

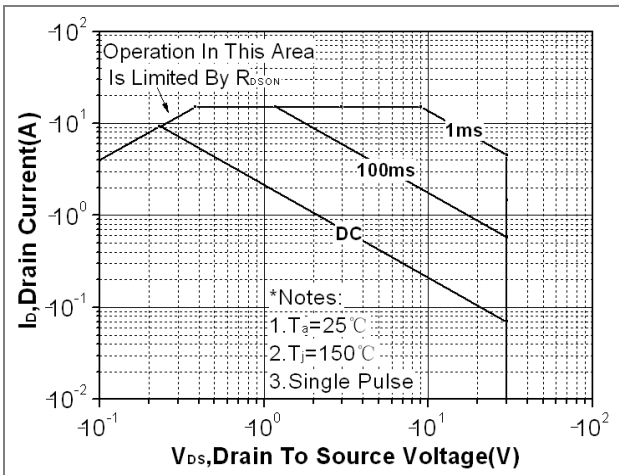

Fig. 10. Transient thermal response curve (SOP-8)

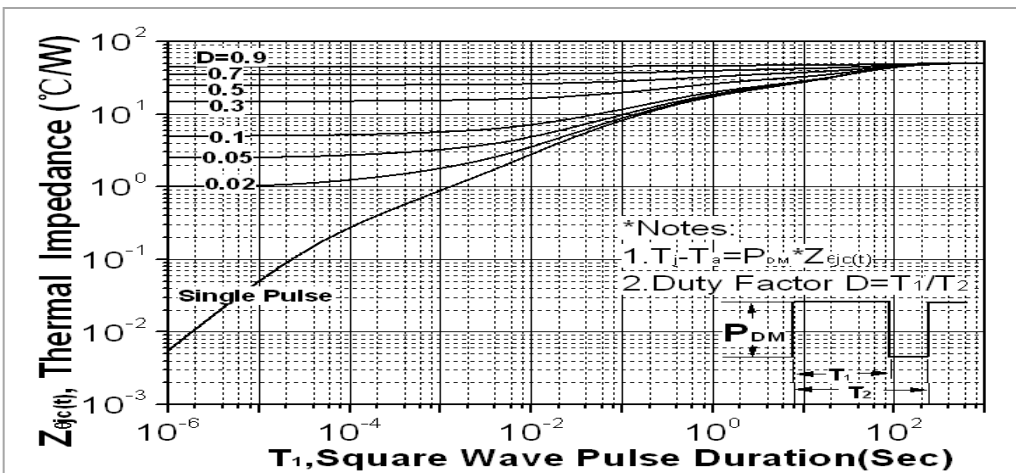

Fig. 11. Transient thermal response curve (DFN3\*3)

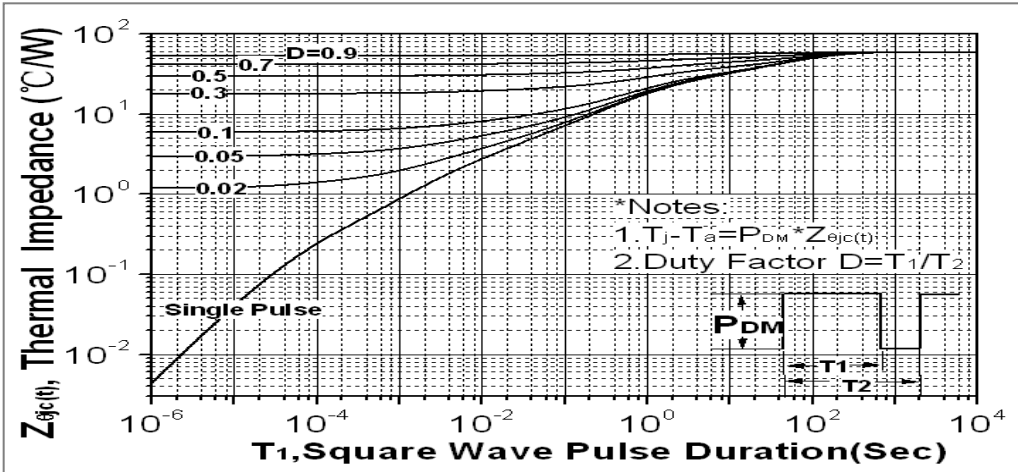

Fig. 12. Gate charge test circuit & waveform

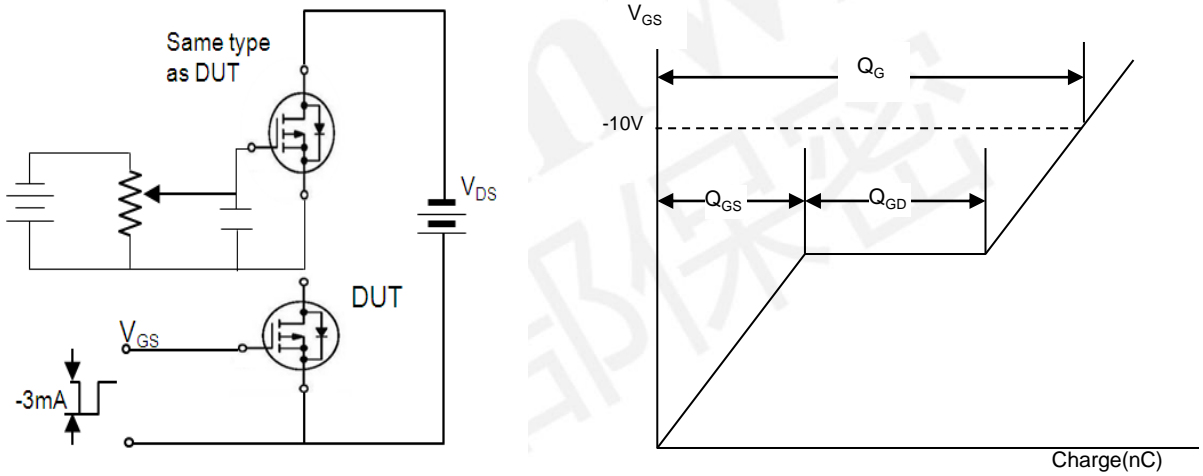
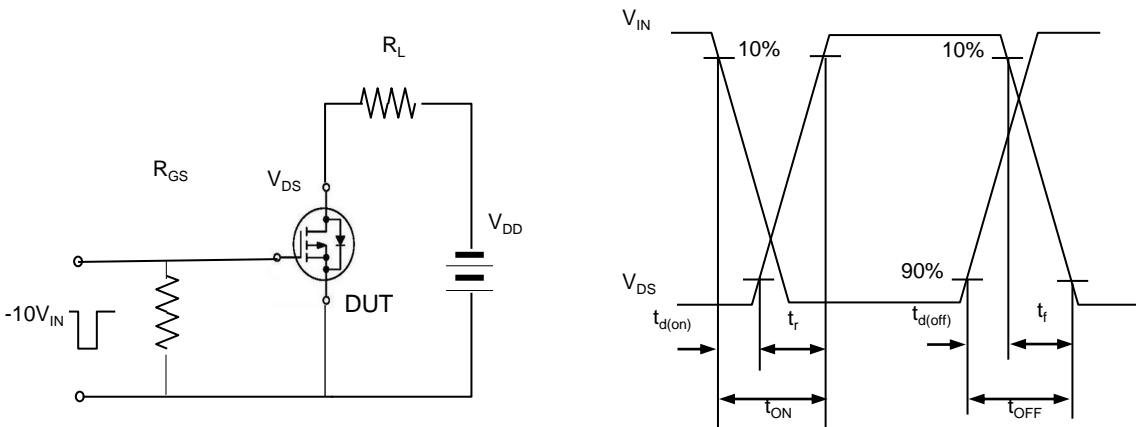
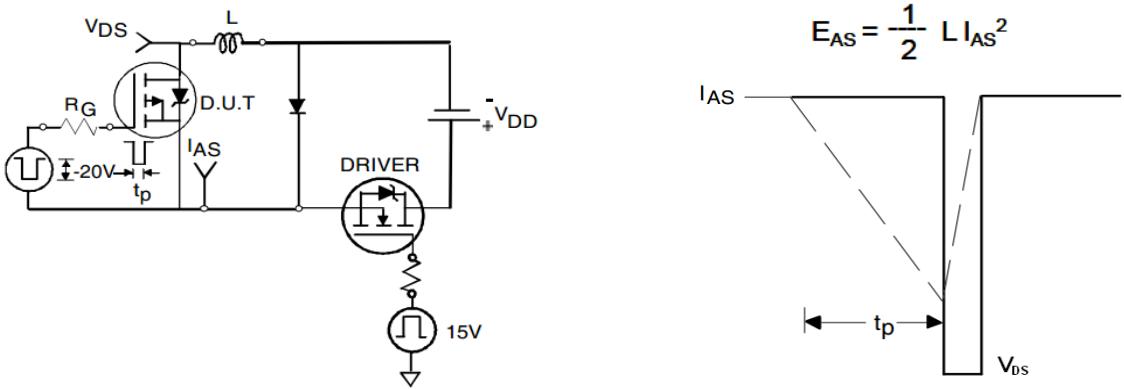

Fig. 13. Switching time test circuit & waveform



**Fig. 14. Unclamped Inductive switching test circuit & waveform**



**Fig. 15. Peak diode recovery dv/dt test circuit & waveform**

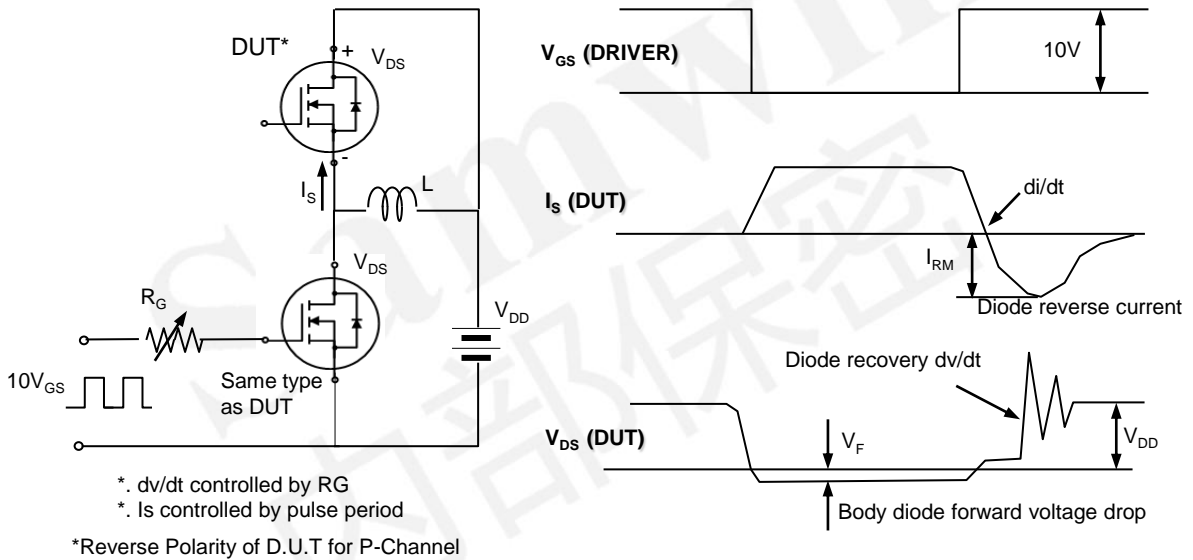

**DISCLAIMER**

\* All the data & curve in this document was tested in XI' AN SEMIPOWER TESTING & APPLICATION CENTE R.

\* This product has passed the PCT,TC,HTRB,HTGB,HAST,PC and Solderdunk reliability testing.

\* Qualification standards can also be found on the Web site (<http://www.semipower.com.cn>)

\* Suggestions for improvement are appreciated, Please send your suggestions to [samwin@winsemi.com](mailto:samwin@winsemi.com)