

1 MHz Bandwidth Low Power Op Amp

Features

- 1 MHz Gain Bandwidth Product (typ.)
- Rail-to-Rail Input/Output
- Supply Voltage: 1.8V to 5.5V
- Supply Current: $I_Q = 100 \mu\text{A}$ (typ.)
- 90° Phase Margin (typ.)
- Temperature Range:
 - Industrial: -40°C to +85°C
 - Extended: -40°C to +125°C
- Available in Single, Dual and Quad Packages

Applications

- Automotive
- Portable Equipment
- Photodiode Pre-amps
- Analog Filters
- Notebooks and PDAs
- Battery-Powered Systems

Description

LMV932 operational amplifiers (op amps) is specifically designed for general-purpose applications. This family has a 1 MHz gain bandwidth product and 90° phase margin (typ.). It also maintains 45° phase margin (typ.) with 500 pF capacitive load. This family operates from a single supply voltage as low as 1.8V, while drawing 100 μA (typ.) quiescent current. Additionally, the LM932 supports rail-to-rail input and output swing with a common mode input voltage range of $V_{DD} + 300 \text{ mV}$ to $V_{SS} - 300 \text{ mV}$. This family of operational amplifiers is designed with Microchip's advanced CMOS process.

The LMV932 family is available in the industrial and extended temperature ranges. It also has a power supply range of 1.8V to 5.5V.

Package Types

Typical Application

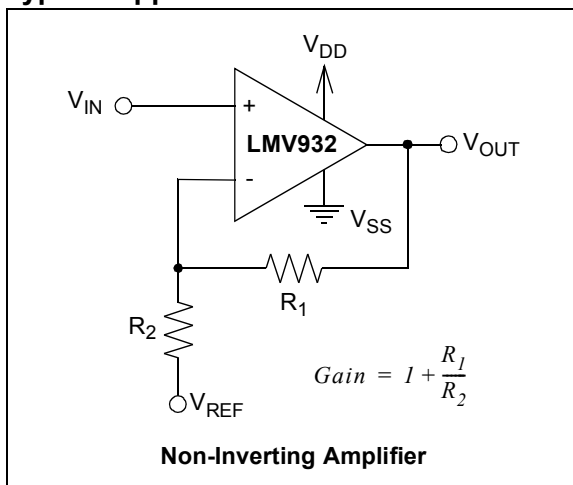

LMV932

PDIP, SOIC, MSOP

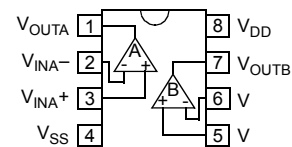

1.0 ELECTRICAL CHARACTERISTICS

Absolute Maximum Ratings †

$V_{DD} - V_{SS}$	7.0V
All Inputs and Outputs	$V_{SS} - 0.3V$ to $V_{DD} + 0.3V$
Difference Input Voltage	$ V_{DD} - V_{SS} $
Output Short Circuit Current	continuous
Current at Input Pins	± 2 mA
Current at Output and Supply Pins	± 30 mA
Storage Temperature	-65°C to $+150^{\circ}\text{C}$
Maximum Junction Temperature (T_J)	$+150^{\circ}\text{C}$
ESD Protection On All Pins (HBM;MM)	≥ 4 kV; 200V

† **Notice:** Stresses above those listed under “Maximum Ratings” may cause permanent damage to the device. This is a stress rating only and functional operation of the device at those or any other conditions above those indicated in the operational listings of this specification is not implied. Exposure to maximum rating conditions for extended periods may affect device reliability.

PIN FUNCTION TABLE

Name	Function
V_{INA+}, V_{INB}	Non-inverting Inputs
V_{INA-}, V_{INB}	Inverting Inputs
V_{DD}	Positive Power Supply
V_{SS}	Negative Power Supply
V_{OUTA}, V_{OUTB}	Outputs

DC ELECTRICAL SPECIFICATIONS

Electrical Characteristics: Unless otherwise indicated, $T_A = +25^{\circ}\text{C}$, $V_{DD} = +1.8\text{V}$ to $+5.5\text{V}$, $V_{SS} = \text{GND}$, $V_{CM} = V_{DD}/2$, $R_L = 10$ k Ω to $V_{DD}/2$, and $V_{OUT} \sim V_{DD}/2$.

Parameters	Sym	Min	Typ	Max	Units	Conditions
Input Offset						
Input Offset Voltage	V_{OS}	-7.0	—	+7.0	mV	$V_{CM} = V_{SS}$
Input Offset Drift with Temperature	$\Delta V_{OS}/\Delta T_A$	—	± 2.0	—	$\mu\text{V}/^{\circ}\text{C}$	$T_A = -40^{\circ}\text{C}$ to $+125^{\circ}\text{C}$, $V_{CM} = V_{SS}$
Power Supply Rejection	PSRR	—	86	—	dB	$V_{CM} = V_{SS}$
Input Bias Current and Impedance						
Input Bias Current:	I_B	—	± 1.0	—	pA	$T_A = +85^{\circ}\text{C}$ $T_A = +125^{\circ}\text{C}$
Industrial Temperature	I_B	—	19	—	pA	
Extended Temperature	I_B	—	1100	—	pA	
Input Offset Current	I_{OS}	—	± 1.0	—	pA	
Common Mode Input Impedance	Z_{CM}	—	$10^{13} 6$	—	$\Omega \mu\text{F}$	
Differential Input Impedance	Z_{DIFF}	—	$10^{13} 3$	—	$\Omega \mu\text{F}$	
Common Mode						
Common Mode Input Range	V_{CMR}	$V_{SS} - 0.3$	—	$V_{DD} + 0.3$	V	
Common Mode Rejection Ratio	CMRR	60	76	—	dB	$V_{CM} = -0.3\text{V}$ to 5.3V , $V_{DD} = 5\text{V}$
Open-Loop Gain						
DC Open-Loop Gain (large signal)	A_{OL}	88	112	—	dB	$V_{OUT} = 0.3\text{V}$ to $V_{DD} - 0.3\text{V}$, $V_{CM} = V_{SS}$
Output						
Maximum Output Voltage Swing	V_{OL}, V_{OH}	$V_{SS} + 25$	—	$V_{DD} - 25$	mV	$V_{DD} = 5.5\text{V}$
Output Short-Circuit Current	I_{SC}	—	± 6	—	mA	$V_{DD} = 1.8\text{V}$
		—	± 23	—	mA	$V_{DD} = 5.5\text{V}$
Power Supply						
Supply Voltage	V_{DD}	1.8	—	5.5	V	
Quiescent Current per Amplifier	I_Q	50	100	170	μA	$I_O = 0$, $V_{DD} = 5.5\text{V}$, $V_{CM} = 5\text{V}$

AC ELECTRICAL SPECIFICATIONS

Electrical Characteristics: Unless otherwise indicated, $T_A = +25^\circ\text{C}$, $V_{DD} = +1.8$ to 5.5V , $V_{SS} = \text{GND}$, $V_{CM} = V_{DD}/2$, $V_{OUT} \approx V_{DD}/2$, $R_L = 10\text{ k}\Omega$ to $V_{DD}/2$, and $C_L = 60\text{ pF}$.

Parameters	Sym	Min	Typ	Max	Units	Conditions
AC Response						
Gain Bandwidth Product	GBWP	—	1.0	—	MHz	
Phase Margin	PM	—	90	—	°	G = +1
Slew Rate	SR	—	0.6	—	V/ μs	
Noise						
Input Noise Voltage	E_{ni}	—	6.1	—	$\mu\text{Vp-p}$	f = 0.1 Hz to 10 Hz
Input Noise Voltage Density	e_{ni}	—	28	—	nV/ $\sqrt{\text{Hz}}$	f = 1 kHz
Input Noise Current Density	i_{ni}	—	0.6	—	fA/ $\sqrt{\text{Hz}}$	f = 1 kHz

2.0 TYPICAL PERFORMANCE CURVES

Note: The graphs and tables provided following this note are a statistical summary based on a limited number of samples and are provided for informational purposes only. The performance characteristics listed herein are not tested or guaranteed. In some graphs or tables, the data presented may be outside the specified operating range (e.g., outside specified power supply range) and therefore outside the warranted range.

Note: Unless otherwise indicated, $T_A = +25^\circ\text{C}$, $V_{DD} = +1.8\text{V}$ to $+5.5\text{V}$, $V_{SS} = \text{GND}$, $V_{CM} = V_{DD}/2$, $V_{OUT} \approx V_{DD}/2$, $R_L = 10\text{ k}\Omega$ to $V_{DD}/2$, and $C_L = 60\text{ pF}$.

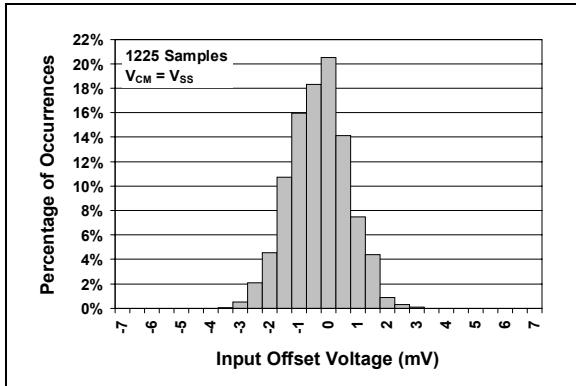

FIGURE 2-1: Input Offset Voltage Histogram.

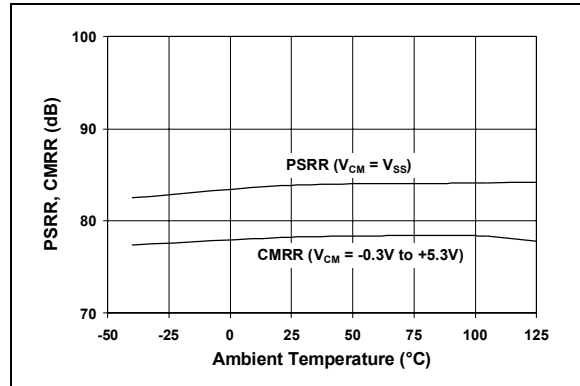

FIGURE 2-4: CMRR, PSRR vs. Ambient Temperature.

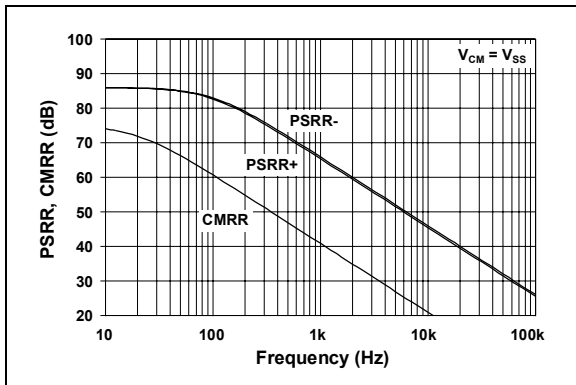

FIGURE 2-2: PSRR, CMRR vs. Frequency.

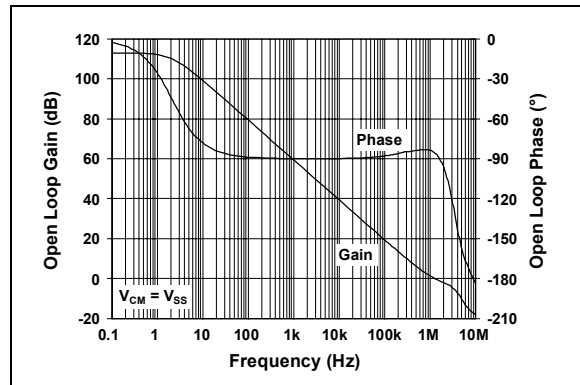

FIGURE 2-5: Open-Loop Gain, Phase vs. Frequency.

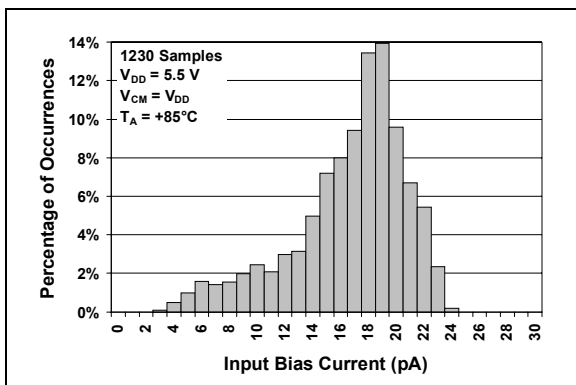

FIGURE 2-3: Input Bias Current at $+85^\circ\text{C}$ Histogram.

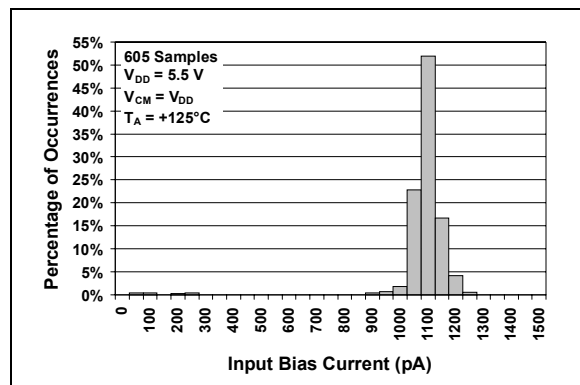

FIGURE 2-6: Input Bias Current at $+125^\circ\text{C}$ Histogram.

Note: Unless otherwise indicated, $T_A = +25^\circ\text{C}$, $V_{DD} = +1.8\text{V}$ to $+5.5\text{V}$, $V_{SS} = \text{GND}$, $V_{CM} = V_{DD}/2$, $V_{OUT} \approx V_{DD}/2$, $R_L = 10\text{ k}\Omega$ to $V_{DD}/2$, and $C_L = 60\text{ pF}$.

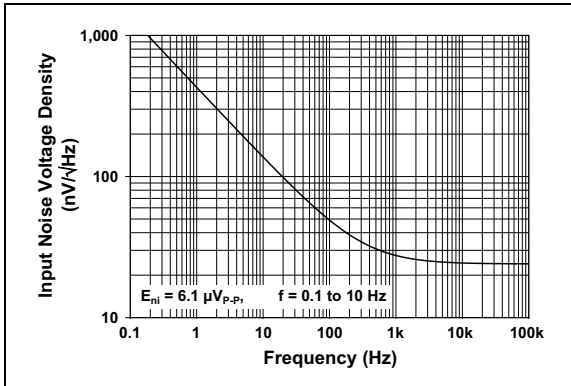

FIGURE 2-7: Input Noise Voltage Density vs. Frequency.

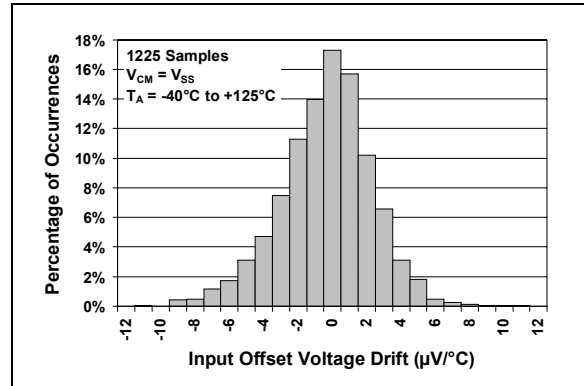

FIGURE 2-10: Input Offset Voltage Drift Histogram.

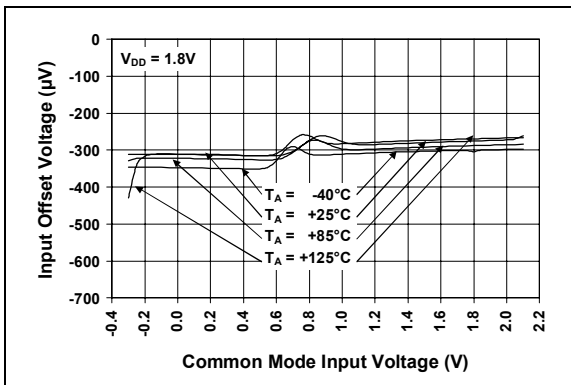

FIGURE 2-8: Input Offset Voltage vs. Common Mode Input Voltage at $V_{DD} = 1.8\text{V}$.

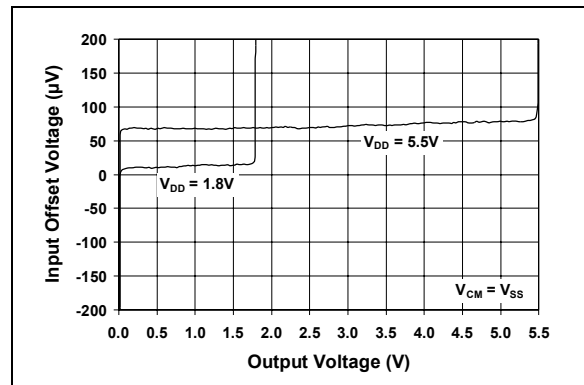

FIGURE 2-11: Input Offset Voltage vs. Output Voltage.

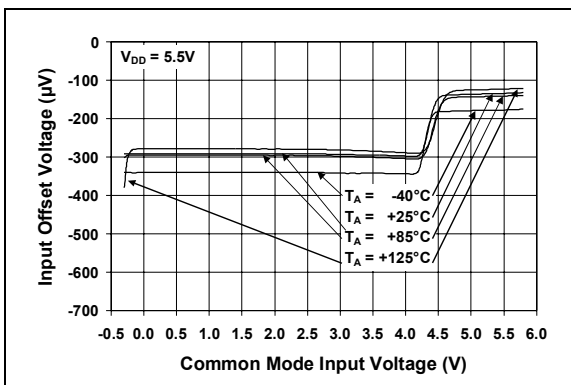

FIGURE 2-9: Input Offset Voltage vs. Common Mode Input Voltage at $V_{DD} = 5.5\text{V}$.

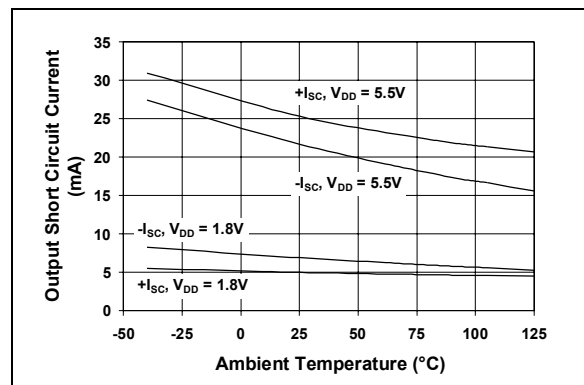

FIGURE 2-12: Output Short-Circuit Current vs. Ambient Temperature.

Note: Unless otherwise indicated, $T_A = +25^\circ\text{C}$, $V_{DD} = +1.8\text{V}$ to $+5.5\text{V}$, $V_{SS} = \text{GND}$, $V_{CM} = V_{DD}/2$, $V_{OUT} \approx V_{DD}/2$, $R_L = 10\text{ k}\Omega$ to $V_{DD}/2$, and $C_L = 60\text{ pF}$.

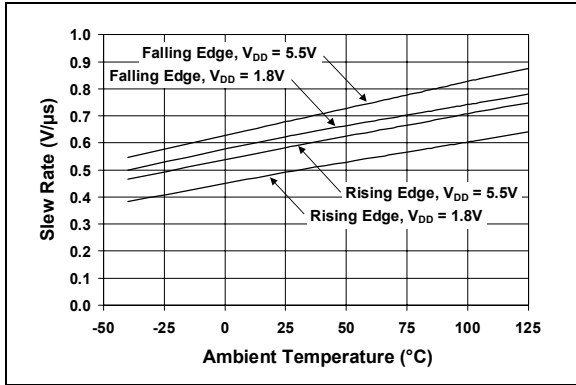

FIGURE 2-13: Slew Rate vs. Ambient Temperature.

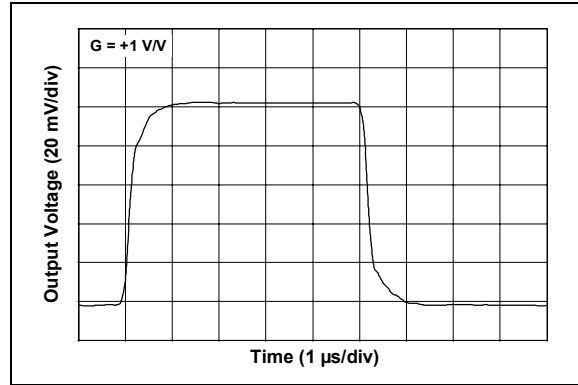

FIGURE 2-16: Small Signal Non-Inverting Pulse Response.

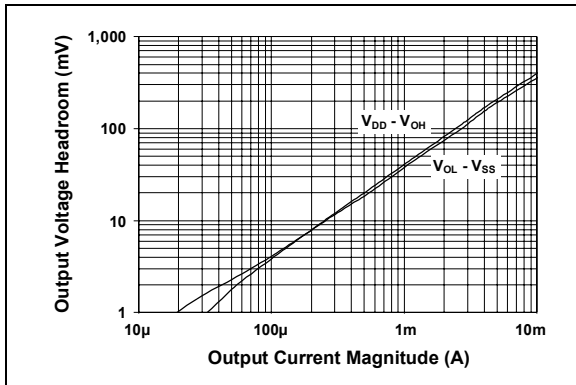

FIGURE 2-14: Output Voltage Headroom vs. Output Current Magnitude.

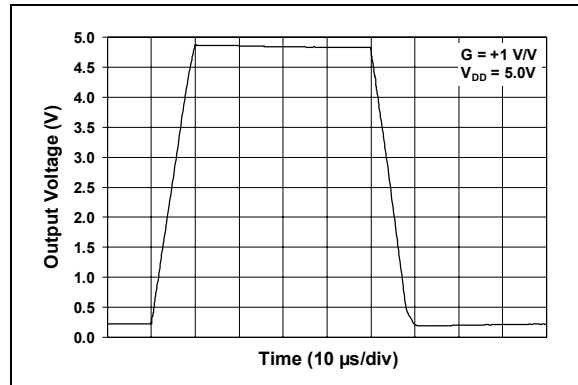

FIGURE 2-17: Large Signal Non-Inverting Pulse Response.

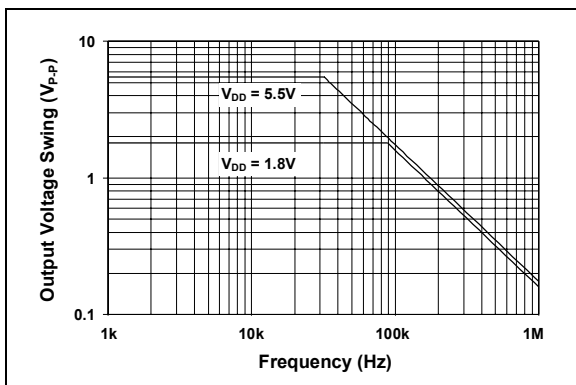

FIGURE 2-15: Output Voltage Swing vs. Frequency.

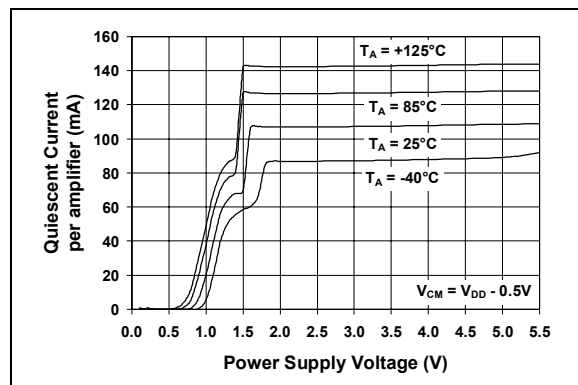

FIGURE 2-18: Quiescent Current vs. Power Supply Voltage.