

APPROVAL SPECIFICATIONS

Title. NANO SIM+NANO SIM+TF三選二一體式

Product Model. MCS-302-C1

Customer's Part NO.

Customer's Model:

Customer's Approval Requested.

Please return this copy as a certification of your approval.

Checked by: _____ Date: _____

Approved by: _____ Date: _____

APPROVE	REVIEW	POLT
王凯	林永坚	陈旺

XUNPU ELECTRONICS CO.,LTD

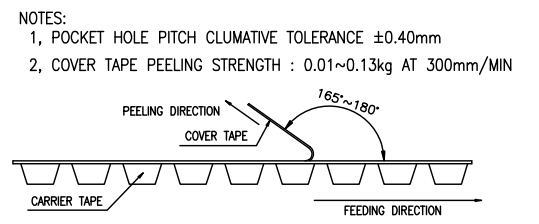
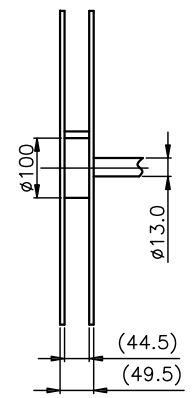
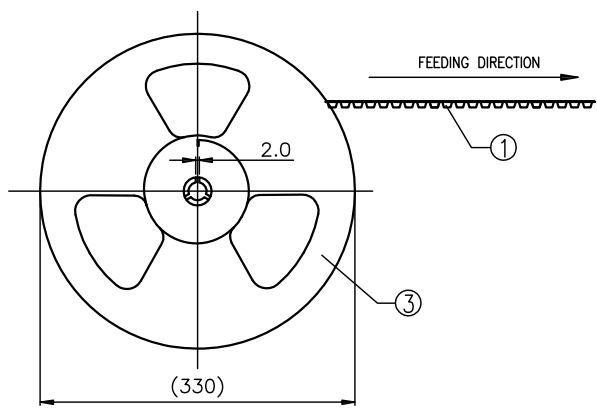
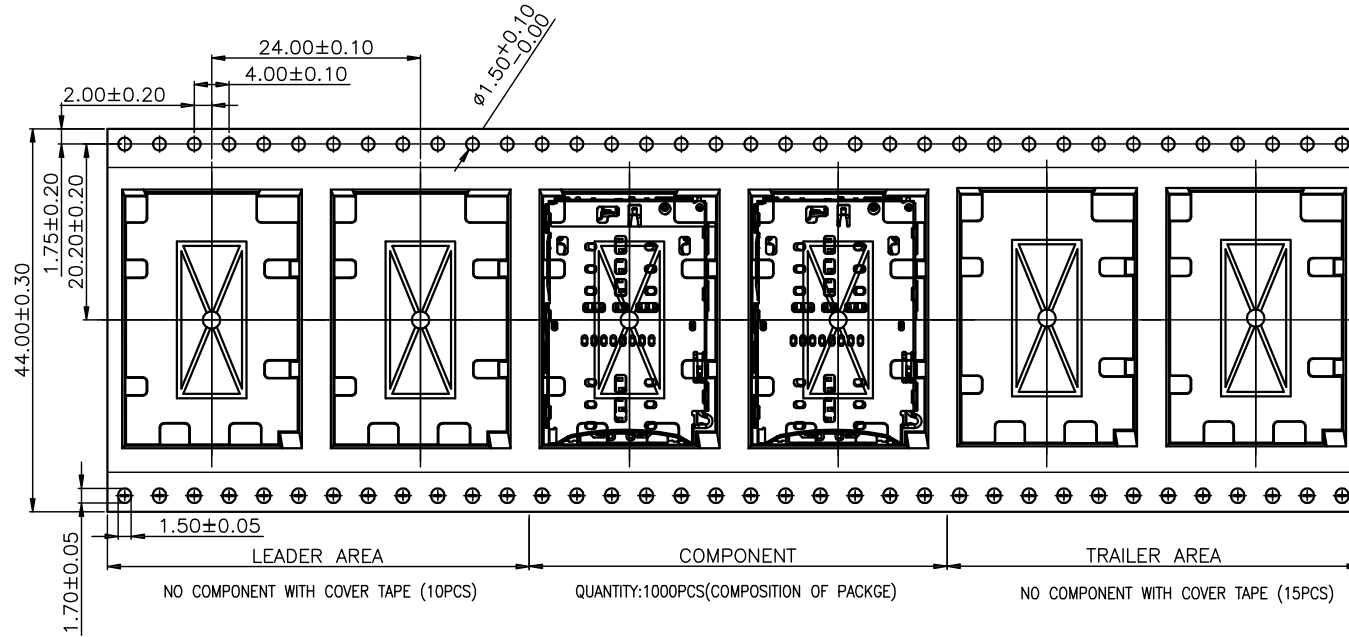

- A3** 3, Packaging capacity:
 1000pcs/REEL; 6REEL/CARTON ; TOTAL: 6000PCS/CARTON
- 4, Packaging Use Attention:
 NOT TWISTED OVER 90° WITHIN 1000mm.

UNLESS OTHERWISE SPECIFIED TOLERANCES		東莞市訊普電子科技有限公司			
DECIMALS:	ANGLES:	TITLE	1.35H Nano&tf 3in2 with tray (Pin Push)Conn.Assem.		
X :±0.5	X :±2°	DWN	ALLEN	PART NO. MCS-302-C1	
X.X :±0.20	X.X :±1°	CHKD	KEVIN	SCALE:1:1	UNIT: mm
X.XX :±0.10		APVD	ERIC.W	SIZE: A3	SHEET: 3 OF 4
		REV: B			
CUSTOMER COPY					

