



SGM4717

4.5Ω, 300MHz Bandwidth, Dual, SPDT Analog Switch

GENERAL DESCRIPTION

The SGM4717 is a dual, bidirectional, single-pole/double-throw (SPDT) CMOS analog switch designed to operate from a single 1.8V to 5.5V supply. It features high-bandwidth (300MHz) and low on-resistance (4.5Ω TYP), targeted applications for audio switching.

SGM4717 features guaranteed on-resistance matching (0.3Ω MAX) between switches and guaranteed on-resistance flatness over the signal range (2.3Ω TYP). This ensures excellent linearity and low distortion when switching audio signals.

The SGM4717 is a committed dual single-pole/double-throw (SPDT) that consist of two normally open (NO) and two normally close (NC) switches. This configuration can be used as a dual 2-to-1 multiplexer.

SGM4717 is available in Green WLCSP-2.0×1.5-10B and MSOP-10 packages.

APPLICATIONS

- Portable Instrumentation
- Battery-Operated Equipment
- Computer Peripherals
- Cell Phones
- PDA's
- MP3's

FUNCTION TABLE

LOGIC	NO	NC
0	OFF	ON
1	ON	OFF

Switches Shown For Logic "0" Input

FEATURES

- Voltage Operation: 1.8V to 5.5V
- On-Resistance: 4.5Ω (TYP) at 5.0V
- High Bandwidth: 300MHz
- Fast Switching Times
 - t_{ON} 26ns
 - t_{OFF} 20ns
- High Off-Isolation: -57dB at 10MHz
- Low Crosstalk: -99dB at 10MHz
- Rail-to-Rail Operation
- TTL/CMOS Compatible
- Break-Before-Make Switching
- Extended Industrial Temperature Range:
 - 40°C to +85°C
- Available in Green WLCSP-2.0×1.5-10B and MSOP-10 Packages

PIN CONFIGURATIONS (TOP VIEW)

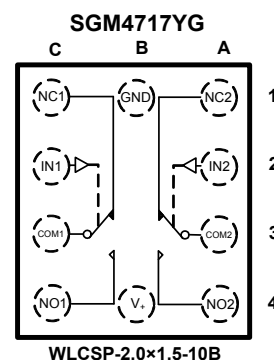
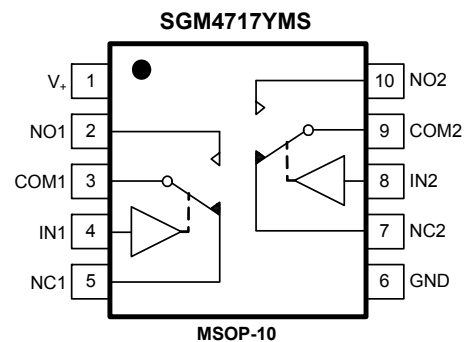

PACKAGE/ORDERING INFORMATION

MODEL	PIN-PACKAGE	SPECIFIED TEMPERATURE RANGE	ORDERING NUMBER	PACKAGE MARKING	PACKAGE OPTION
SGM4717	WLCSP-2.0×1.5-10B	-40°C to +85°C	SGM4717YG/TR	4717YG	Tape and Reel, 3000
	MSOP-10	-40°C to +85°C	SGM4717YMS/TR	SGM4717YMS	Tape and Reel, 3000

ABSOLUTE MAXIMUM RATINGS

V+, IN to GND.....	-0.3V to 6V	Junction Temperature.....	150°C
Analog, Digital voltage range ⁽¹⁾	-0.3V to (V ₊) + 0.3V	Storage Temperature Range.....	- 65°C to +150°C
Continuous Current NO, NC, or COM.....	±50mA	Lead Temperature (soldering, 10s).....	260°C
Peak Current NO, NC, or COM	±80mA	ESD (HBM).....	2000V
Operating Temperature Range.....	-40°C to +85°C		

NOTES:

1. Signals on NC, NO, or COM or IN exceeding V₊ will be clamped by internal diodes. Limit forward diode current to maximum current ratings.
2. Stresses beyond those listed under “Absolute Maximum Ratings” may cause permanent damage to the device. These are stress ratings only, and functional operation of the device at these or any other conditions beyond those indicated in the operational sections of the specifications is not implied. Exposure to absolute maximum rating conditions for extended periods may affect device reliability.

CAUTION

This integrated circuit can be damaged by ESD if you don't pay attention to ESD protection. SGMICRO recommends that all integrated circuits be handled with appropriate precautions. Failure to observe proper handling and installation procedures can cause damage. ESD damage can range from subtle performance degradation to complete device failure. Precision integrated circuits may be more susceptible to damage because very small parametric changes could cause the device not to meet its published specifications.

SGMICRO reserves the right to make any change in circuit design, specification or other related things if necessary without notice at any time. Please contact SGMICRO sales office to get the latest datasheet.

PIN DESCRIPTION

NAME	FUNCTION
V ₊	Power Supply.
GND	Ground.
IN1, IN2	Digital Control Pin to Connect the COM Terminal to the NO or NC Terminals.
COM1, COM2	Common Terminal.
NO1, NO2	Normally-Open Terminal.
NC1, NC2	Normally-Closed Terminal.

NOTE: NO, NC and COM terminals may be an input or output.

ELECTRICAL CHARACTERISTICS

(V_+ = +4.5V to +5.5V, V_{IH} = +2.0V, V_{IL} = +0.8V, T_A = -40°C to +85°C. Typical values are at V_+ = +5.0V, T_A = +25°C, unless otherwise noted.)

PARAMETER	SYMBOL	CONDITIONS	TEMP	MIN	TYP	MAX	UNITS
ANALOG SWITCH							
Analog Signal Range	V_{NO}, V_{NC}, V_{COM}		-40°C to +85°C	0		V_+	V
On-Resistance	R_{ON}	V_+ = 4.5V, V_{NO} or V_{NC} = 3.5V, I_{COM} = -10mA, Test Circuit 1	+25°C		4.5	8	Ω
			-40°C to +85°C			8.5	Ω
On-Resistance Match Between Channels	ΔR_{ON}	V_+ = 4.5V, V_{NO} or V_{NC} = 3.5V, I_{COM} = -10mA, Test Circuit 1	+25°C		0.15	0.3	Ω
			-40°C to +85°C			0.4	Ω
On-Resistance Flatness	$R_{FLAT(ON)}$	V_+ = 4.5V, V_{NO} or V_{NC} = 1.0V, 2.0V, 3.5V, I_{COM} = -10mA, Test Circuit 1	+25°C		2.3	3.3	Ω
			-40°C to +85°C			3.7	Ω
Source OFF Leakage Current	$I_{NC(OFF)}, I_{NO(OFF)}$	V_+ = 5.5V, V_{NO} or V_{NC} = 1.0V, 4.5V, V_{COM} = 4.5V, 1.0V	-40°C to +85°C			1	μA
Channel ON Leakage Current	$I_{NC(ON)}, I_{NO(ON)}, I_{COM(ON)}$	V_+ = 5.5V, V_{COM} = 1.0V, 4.5V, V_{NO} or V_{NC} = 1.0V, 4.5V, or floating	-40°C to +85°C			1	μA
DIGITAL INPUTS							
Input High Voltage	V_{INH}		-40°C to +85°C	1.5			V
Input Low Voltage	V_{INL}		-40°C to +85°C			0.6	V
Input Leakage Current	I_{IN}	V_+ = 5.5V, V_{IN} = 0V or 5.5V	-40°C to +85°C			1	μA
DYNAMIC CHARACTERISTICS							
Turn-On Time	t_{ON}	V_{NO} or V_{NC} = 3.0V, V_{IH} = 1.5V, V_{IL} = 0V, R_L = 300Ω, C_L = 35pF, Test Circuit 2	+25°C		26		ns
Turn-Off Time	t_{OFF}	V_{NO} or V_{NC} = 3.0V, V_{IH} = 1.5V, V_{IL} = 0V, R_L = 300Ω, C_L = 35pF, Test Circuit 2	+25°C		20		ns
Break-Before-Make Time Delay	t_D	V_{NO1} or V_{NC1} = V_{NO2} or V_{NC2} = 3V, R_L = 300Ω, C_L = 35pF, Test Circuit 3	+25°C		4		ns
Skew	t_{SKEW}	R_S = 39Ω, C_L = 50pF, Test Circuit 4	+25°C		5.8		ns
Off Isolation	O_{ISO}	R_L = 50Ω, C_L = 5pF, Signal = 0dBm, Test Circuit 5	f = 10MHz	+25°C		-57	dB
			f = 1MHz	+25°C		-76	dB
Channel-to-Channel Crosstalk	X_{TALK}	R_L = 50Ω, C_L = 5pF, Test Circuit 6	f = 10MHz	+25°C		-99	dB
			f = 1MHz	+25°C		-110	dB
-3dB Bandwidth	BW	Signal = 0dBm, R_L = 50Ω, C_L = 5pF, Test Circuit 7	+25°C		300		MHz
Source OFF Capacitance	$C_{NC(OFF)}, C_{NO(OFF)}$	f = 1MHz	+25°C		5.5		pF
Channel ON Capacitance	$C_{NC(ON)}, C_{NO(ON)}, C_{COM(ON)}$	f = 1MHz	+25°C		15.5		pF
POWER REQUIREMENTS							
Power Supply Range	V_+		-40°C to +85°C	1.8		5.5	V
Power Supply Current	I_+	V_+ = 5.5V, V_{IN} = 0V or V_+	-40°C to +85°C			5	μA

ELECTRICAL CHARACTERISTICS

(V_+ = +2.7V to +3.6V, V_{IH} = +1.4V, V_{IL} = +0.5V, T_A = -40°C to +85°C. Typical values are at V_+ = +3.0V, T_A = +25°C, unless otherwise noted.)

PARAMETER	SYMBOL	CONDITIONS	TEMP	MIN	TYP	MAX	UNITS
ANALOG SWITCH							
Analog Signal Range	V_{NO}, V_{NC}, V_{COM}		-40°C to +85°C	0		V_+	V
On-Resistance	R_{ON}	$V_+ = 2.7V, V_{NO}$ or $V_{NC} = 1.5V,$ $I_{COM} = -10mA,$ Test Circuit 1	+25°C		7	10	Ω
			-40°C to +85°C			10.5	Ω
On-Resistance Match Between Channels	ΔR_{ON}	$V_+ = 2.7V, V_{NO}$ or $V_{NC} = 1.5V,$ $I_{COM} = -10mA,$ Test Circuit 1	+25°C		0.15	0.3	Ω
			-40°C to +85°C			0.4	Ω
On-Resistance Flatness	$R_{FLAT(ON)}$	$V_+ = 2.7V, V_{NO}$ or $V_{NC} = 1.0V, 1.5V, 2.0V,$ $I_{COM} = -10mA,$ Test Circuit 1	+25°C		3	4	Ω
			-40°C to +85°C			4.3	Ω
Source OFF Leakage Current	$I_{NC(OFF)}, I_{NO(OFF)}$	$V_+ = 3.6V, V_{NO}$ or $V_{NC} = 0.3V, 3.3V,$ $V_{COM} = 3.3V, 0.3V$	-40°C to +85°C			1	μA
Channel ON Leakage Current	$I_{NC(ON)}, I_{NO(ON)},$ $I_{COM(ON)}$	$V_+ = 3.6V, V_{COM} = 0.3V, 3.3V,$ V_{NO} or $V_{NC} = 0.3V, 3.3V,$ or floating	-40°C to +85°C			1	μA
DIGITAL INPUTS							
Input High Voltage	V_{INH}		-40°C to +85°C	1			V
Input Low Voltage	V_{INL}		-40°C to +85°C			0.5	V
Input Leakage Current	I_{IN}	$V_+ = 5.5V, V_{IN} = 0V$ or 3.6V	-40°C to +85°C			1	μA
DYNAMIC CHARACTERISTICS							
Turn-On Time	t_{ON}	V_{NO} or $V_{NC} = 1.5V, V_{IH} = 1.5V, V_{IL} = 0V,$ $R_L = 300\Omega, C_L = 35pF,$ Test Circuit 2	+25°C		23		ns
Turn-Off Time	t_{OFF}	V_{NO} or $V_{NC} = 1.5V, V_{IH} = 1.5V, V_{IL} = 0V,$ $R_L = 300\Omega, C_L = 35pF,$ Test Circuit 2	+25°C		22		ns
Break-Before-Make Time Delay	t_D	V_{NO1} or $V_{NC1} = V_{NO2}$ or $V_{NC2} = 3V,$ $R_L = 300\Omega, C_L = 35pF,$ Test Circuit 3	+25°C		4		ns
Skew	t_{SKEW}	$R_S = 39\Omega, C_L = 50pF,$ Test Circuit 4	+25°C		5		ns
Off Isolation	O_{ISO}	$R_L = 50\Omega, C_L = 5pF,$ Signal = 0dBm, Test Circuit 5	f = 10MHz	+25°C		-57	dB
			f = 1MHz	+25°C		-76	dB
Channel-to-Channel Crosstalk	X_{TALK}	$R_L = 50\Omega, C_L = 5pF,$ Test Circuit 6	f = 10MHz	+25°C		-98	dB
			f = 1MHz	+25°C		-103	dB
-3dB Bandwidth	BW	Signal = 0dBm, $R_L = 50\Omega, C_L = 5pF,$ Test Circuit 7	+25°C		300		MHz
Source OFF Capacitance	$C_{NC(OFF)},$ $C_{NO(OFF)}$	f = 1MHz	+25°C		5.5		pF
Channel ON Capacitance	$C_{NC(ON)}, C_{NO(ON)},$ $C_{COM(ON)}$	f = 1MHz	+25°C		15.5		pF
POWER REQUIREMENTS							
Power Supply Range	V_+		-40°C to +85°C	1.8		5.5	V
Power Supply Current	I_+	$V_+ = 5.5V, V_{IN} = 0V$ or V_+	-40°C to +85°C			5	μA

TYPICAL PERFORMANCE CHARACTERISTICS

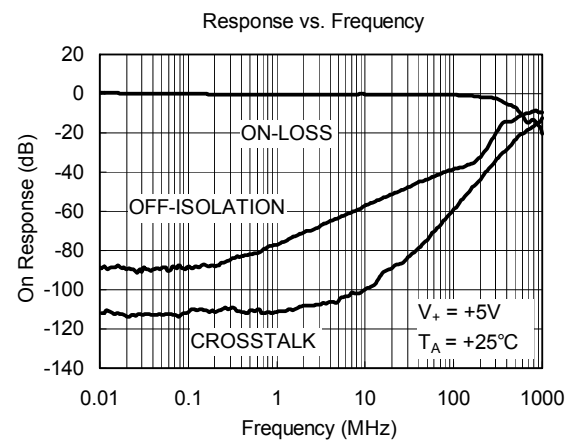
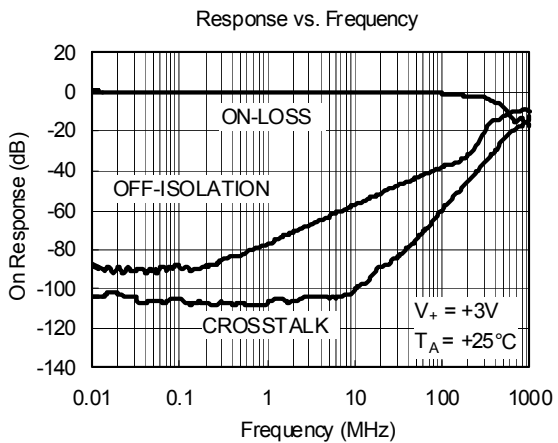
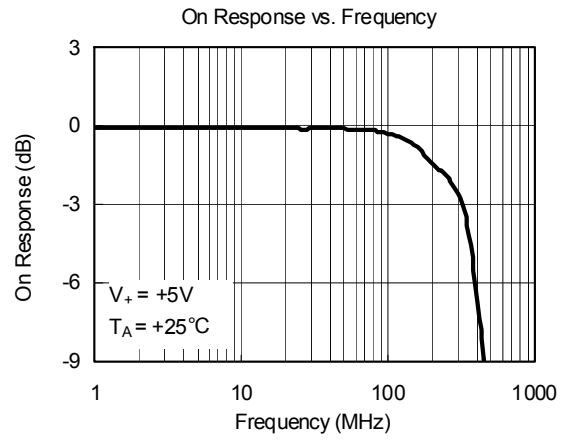
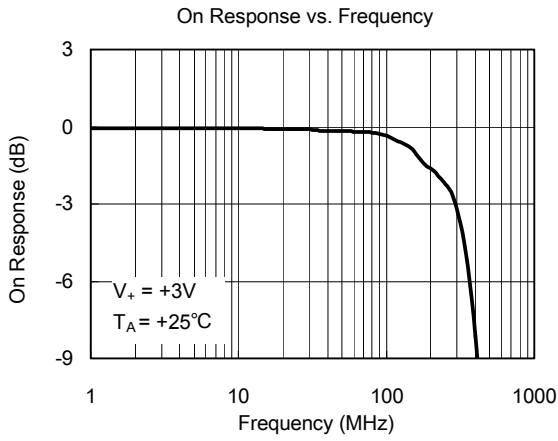

TEST CIRCUITS

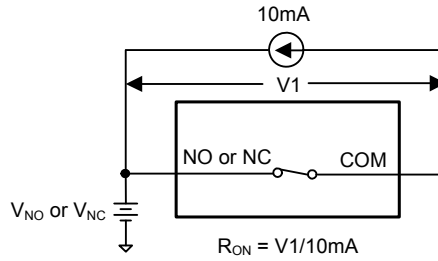

Test Circuit 1. On Resistance

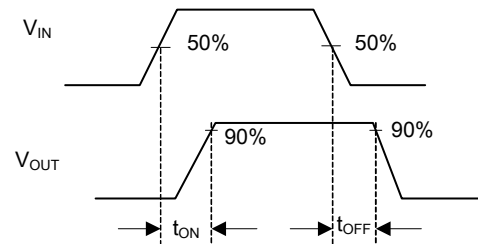
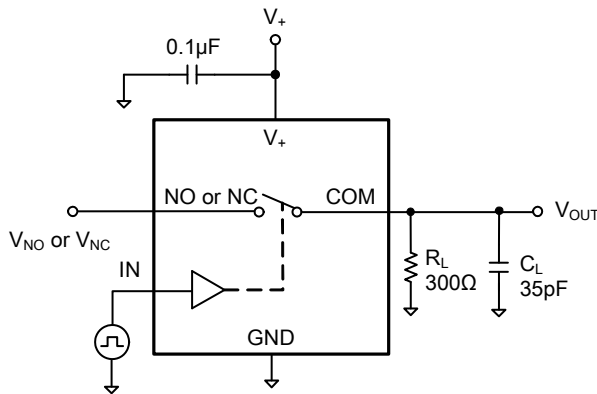

Test Circuit 2. Switching Times

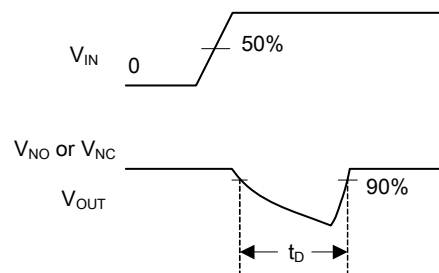
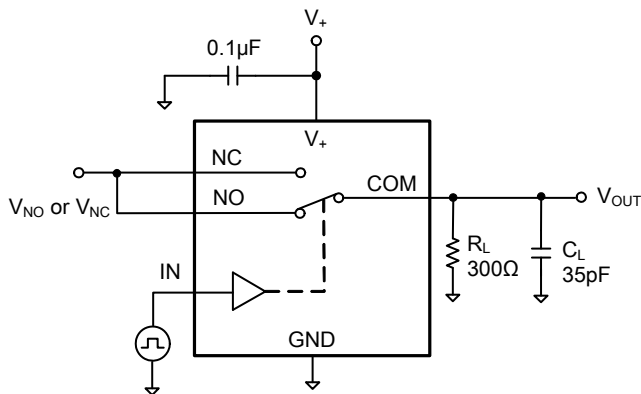

Test Circuit 3. Break-Before-Make Time Delay, t_D

TEST CIRCUITS (Cont.)

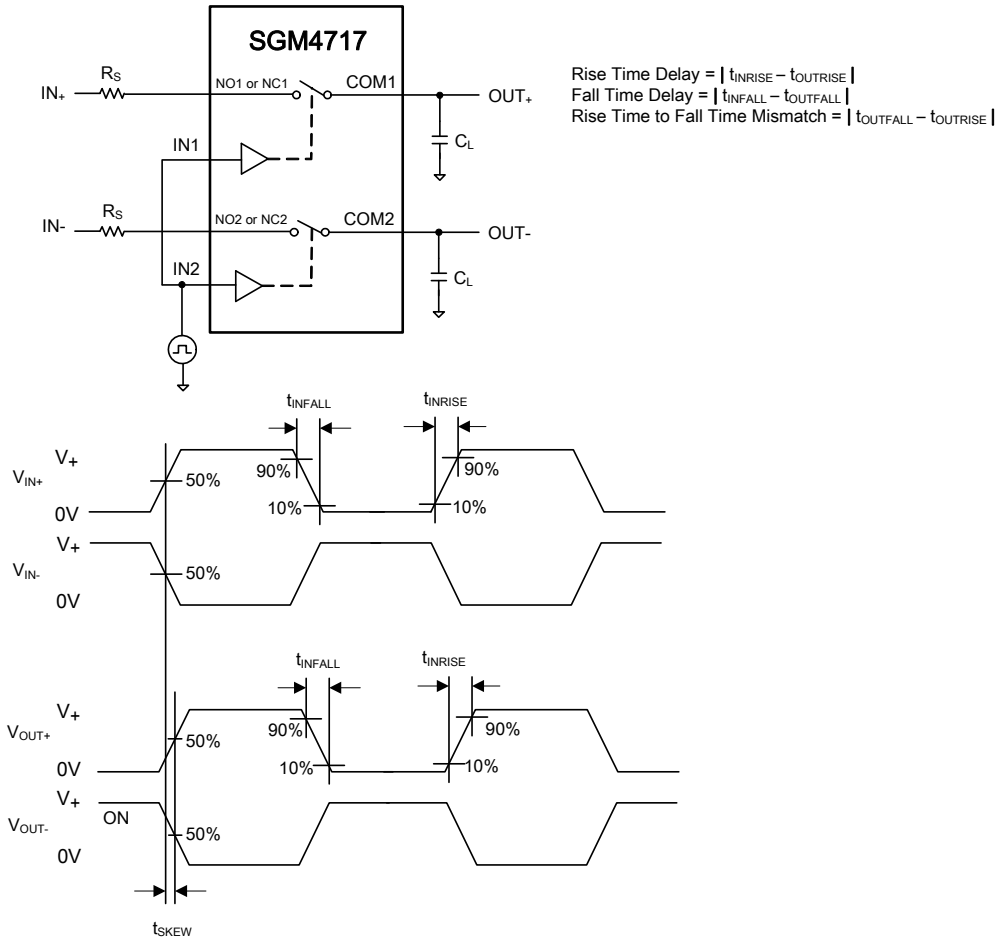

Test Circuit 4. Output Signal Skew

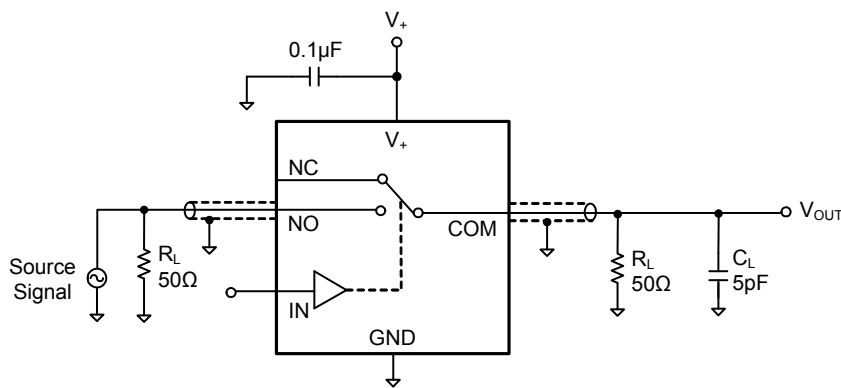

Test Circuit 5. Off Isolation

TEST CIRCUITS (Cont.)

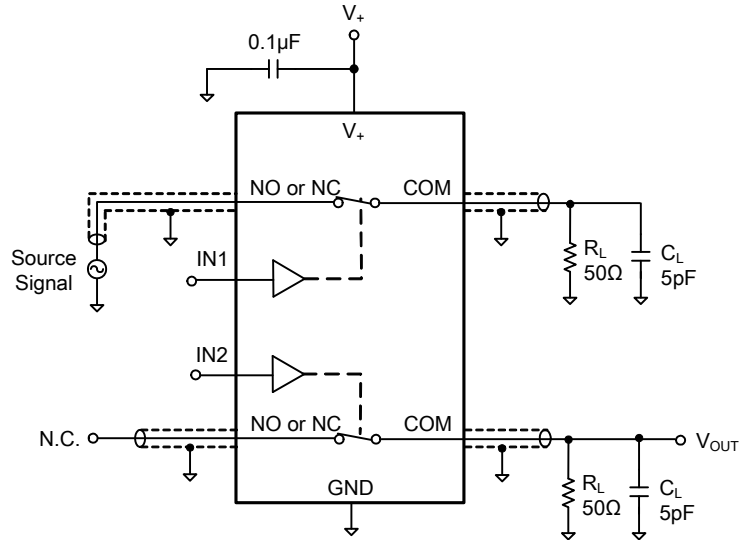

$$\text{Channel To Channel Crosstalk} = -20 \times \log \frac{V_{\text{NO or V}_{\text{NC}}}}{V_{\text{OUT}}}$$

Test Circuit 6. Channel-to-Channel Crosstalk

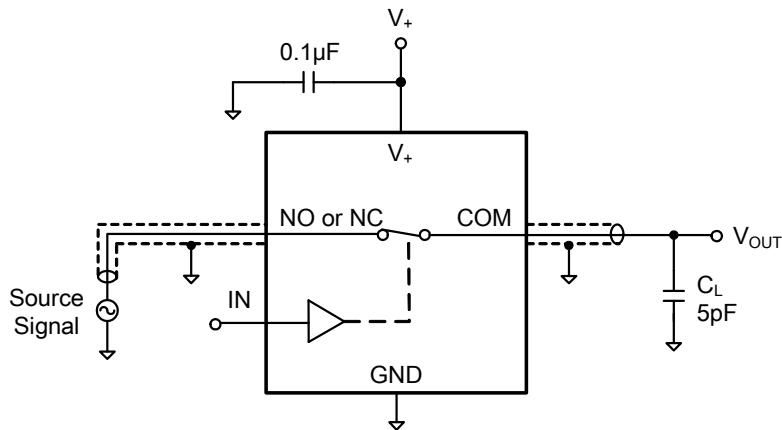

Test Circuit 7. -3dB Bandwidth

PACKAGE OUTLINE DIMENSIONS

WLCSP-2.0×1.5-10B

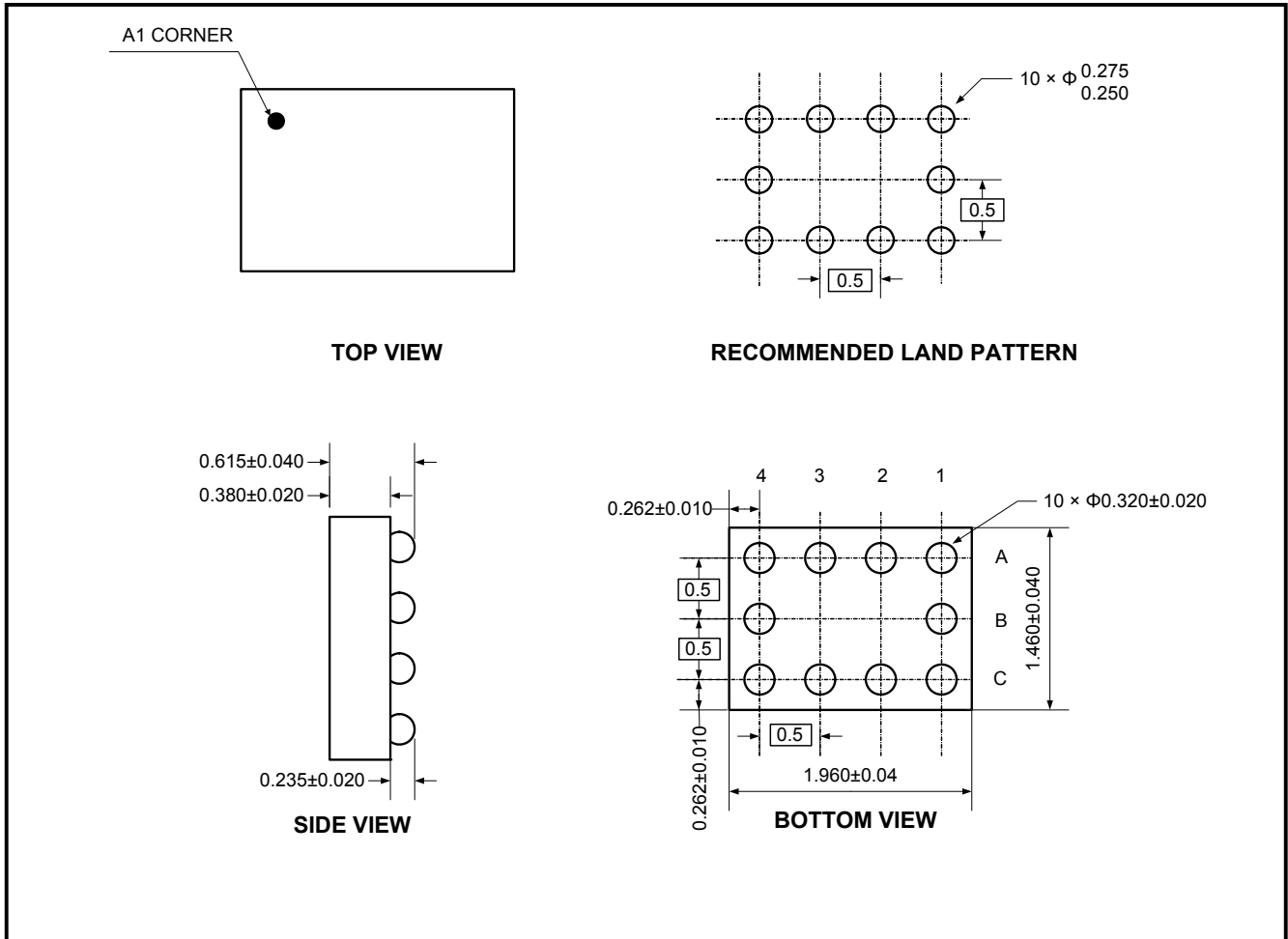

NOTE: All linear dimensions are in millimeters.

PACKAGE OUTLINE DIMENSIONS

MSOP-10

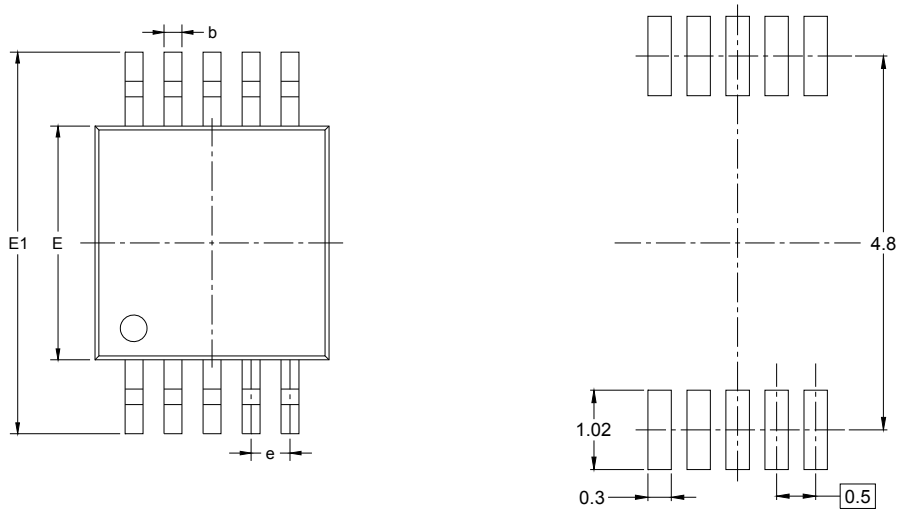

RECOMMENDED LAND PATTERN (Unit: mm)

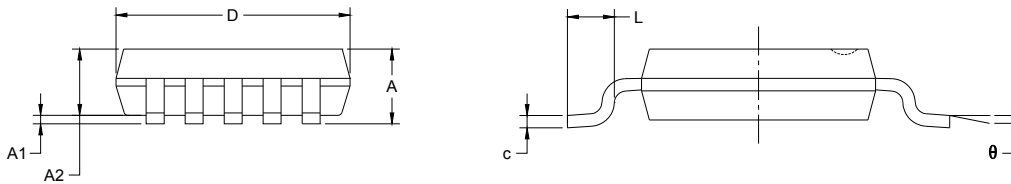

Symbol	Dimensions In Millimeters		Dimensions In Inches	
	MIN	MAX	MIN	MAX
A	0.820	1.100	0.032	0.043
A1	0.020	0.150	0.001	0.006
A2	0.750	0.950	0.030	0.037
b	0.180	0.280	0.007	0.011
c	0.090	0.230	0.004	0.009
D	2.900	3.100	0.114	0.122
E	2.900	3.100	0.114	0.122
E1	4.750	5.050	0.187	0.199
e	0.500 BSC		0.020 BSC	
L	0.400	0.800	0.016	0.031
θ	0°	6°	0°	6°

TAPE AND REEL INFORMATION

REEL DIMENSIONS

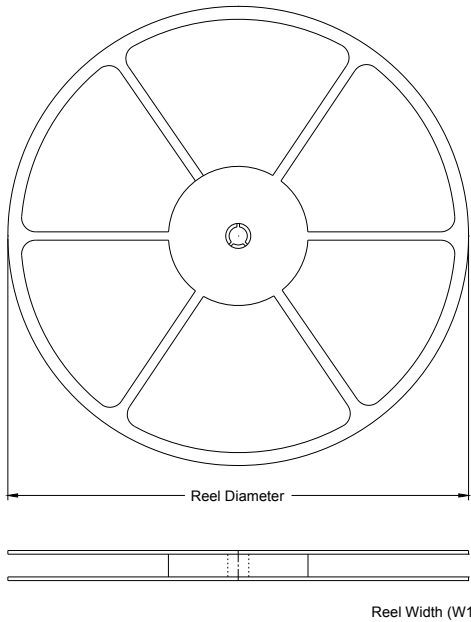

TAPE DIMENSIONS

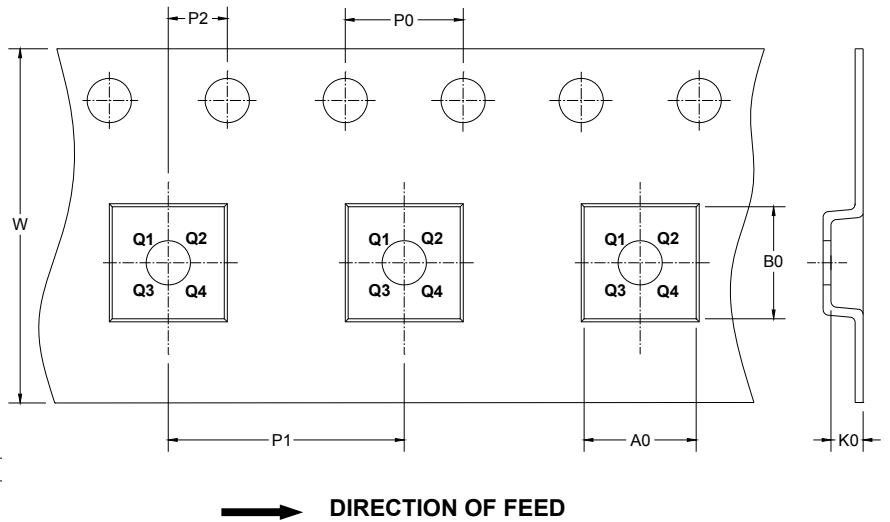

NOTE: The picture is only for reference. Please make the object as the standard.

KEY PARAMETER LIST OF TAPE AND REEL

Package Type	Reel Diameter	Reel Width W1 (mm)	A0 (mm)	B0 (mm)	K0 (mm)	P0 (mm)	P1 (mm)	P2 (mm)	W (mm)	Pin1 Quadrant
MSOP-10	13"	12.4	5.2	3.3	1.2	4.0	8.0	2.0	12.0	Q1
WLCSP-2.0×1.5-10B	7"	9.2	1.7	2.2	0.9	4.0	4.0	2.0	8.0	Q2

SGM4717

CARTON BOX DIMENSIONS

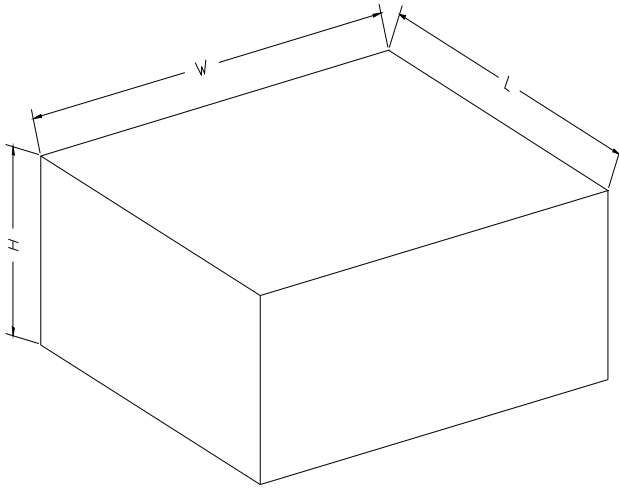

NOTE: The picture is only for reference. Please make the object as the standard.

KEY PARAMETER LIST OF CARTON BOX

Reel Type	Length (mm)	Width (mm)	Height (mm)	Pizza/Carton
7" (Option)	368	227	224	8
7"	442	410	224	18
13"	386	280	370	5