

SE3401B
-2.8A,-20V P-Channel MOSFET

Revision:A

General Description

The MOSFETs from SINO-IC provide the best combination of fast switching, low on-resistance and cost-effectiveness.

Features

- V_{DS} (V) = -20V I_D = -2.8A
- $R_{DS(ON)}$ < 120m Ω (V_{GS} = -4.5V)
- $R_{DS(ON)}$ < 170m Ω (V_{GS} = -2.5V)

Pin configurations

See Diagram below

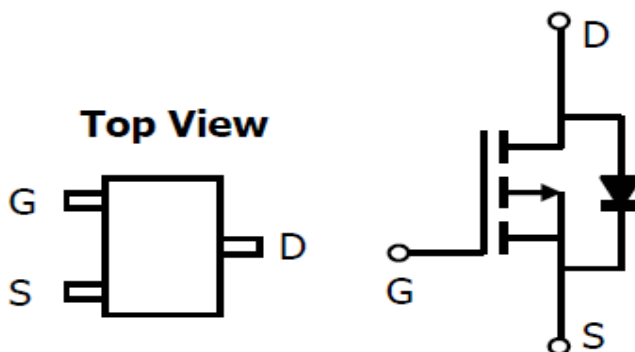

Absolute Maximum Ratings

Parameter		Symbol	Rating	Units
Drain-Source Voltage		V_{DS}	-20	V
Gate-Source Voltage		V_{GS}	± 12	V
Drain Current (Note 1)	Continuous	I_D	-2.8	A
	70°C		-2.2	
Total Power Dissipation		P_D	1.4	W
Operating Junction Temperature Range		T_J	-50 to 150	°C

Thermal Characteristics

Parameter		Symbol	Typ	Max	Units
Maximum Junction-to-Ambient A	Steady-State	$R_{\theta JA}$	65	90	°C/W
Maximum Junction-to-- Case	Steady-State	$R_{\theta JC}$	0.8	-	°C/W

SE3401B

Electrical Characteristics (T _J =25°C unless otherwise noted)						
Symbol	Parameter	Test Conditions	Min	Typ	Max	Units
OFF/ON CHARACTERISTICS (Note 2)						
BV _{DSS}	Drain-Source Breakdown Voltage	I _D =-250 μ A, V _{GS} =0 V	-20			V
I _{DSS}	Zero Gate Voltage Drain Current	V _{DS} =-24 V, V _{GS} =0 V			-1	μ A
I _{GSS}	Gate-Body leakage current	V _{DS} =0 V, V _{GS} =±12 V			±100	nA
V _{GS(th)}	Gate Threshold Voltage	V _{DS} =V _{GS} I _D =-250 μ A	-0.4	-0.7	-1.1	V
R _{DS(ON)}	Static Drain-Source On-Resistance ²	V _{GS} =-4.5V, I _D =-2.8A	-	92	120	mΩ
		V _{GS} =-2.5V, I _D =-2A		130	170	mΩ
V _{SD}	Diode Forward Voltage	V _{GS} =0V, I _D =-1A	-	-0.7	-1	V
DYNAMIC PARAMETERS						
C _{iss}	Input Capacitance	V _{GS} =0V, V _{DS} =-15V, f=1MHz		850		pF
C _{oss}	Output Capacitance			105		pF
C _{rss}	Reverse Transfer Capacitance			68		pF
T _{ON}	Turn-On Time	V _{DS} =-15V, R _L = 3.6 Ω , R _{GEN} = 6 Ω , V _{GS} =-10 V	-	9.5		ns
T _{OFF}	Turn-Off Time			36		ns
T _r	Turn-on Rise Time			3.0		ns
T _f	Turn-on Fall Time			5.2		ns
Q _g	Total Gate Charge	V _{DS} =-4.5V, I _D =-4A, V _{GS} =-15V		7.3		nC
Q _{gs}	Gate-Source Charge			2.2		nC
Q _{gd}	Gate-Drain Charge			2		nC
t _{rr}	Body Diode Reverse Recovery Time	I _F =-4A, dI/dt=100A/ μ s		20.2		ns
Q _{rr}	Body Diode Reverse Recovery Charge	I _F =-4A, dI/dt=100A/ μ s		11.2		nC

Typical Characteristics

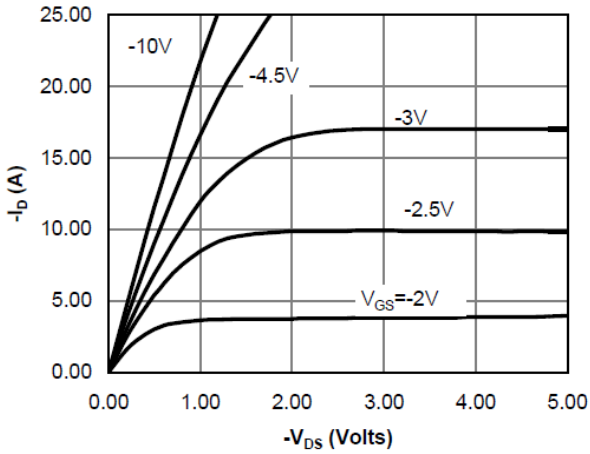

Fig 1: On-Region Characteristics

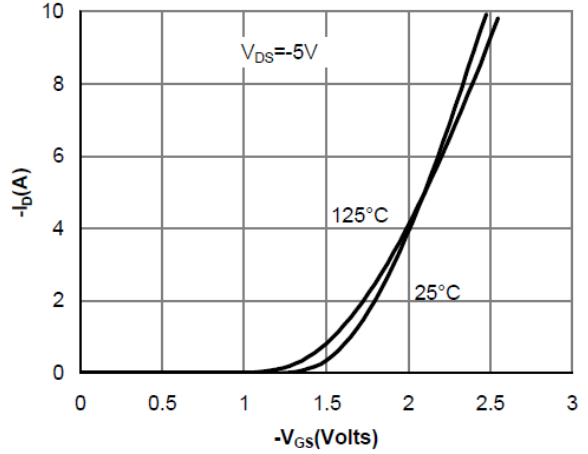

Figure 2: Transfer Characteristics

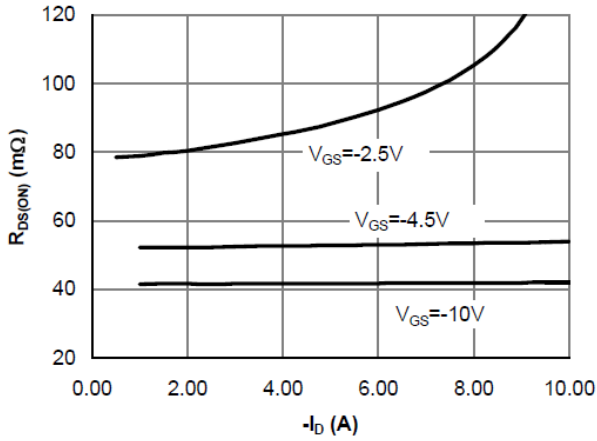

Figure 3: On-Resistance vs. Drain Current and Gate Voltage

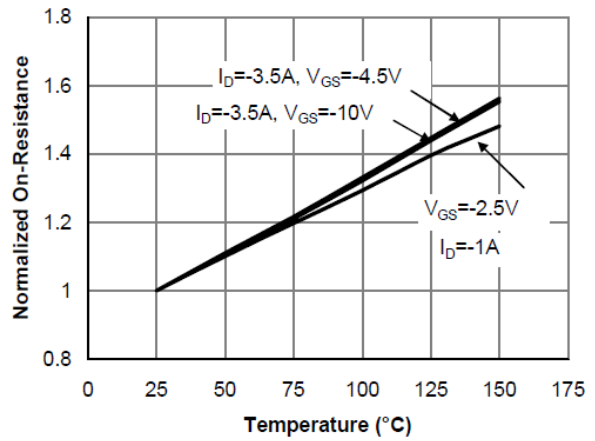

Figure 4: On-Resistance vs. Junction Temperature

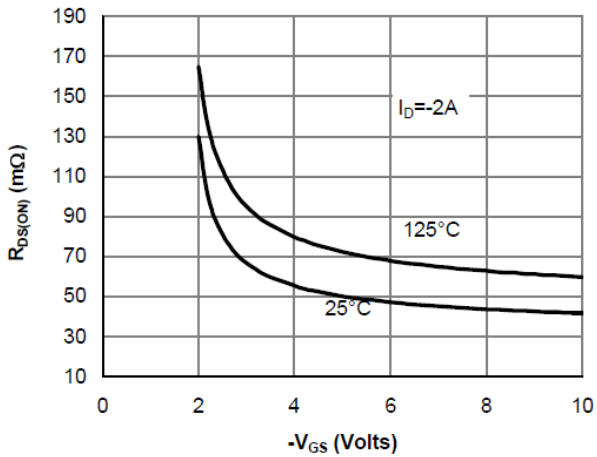

Figure 5: On-Resistance vs. Gate-Source Voltage

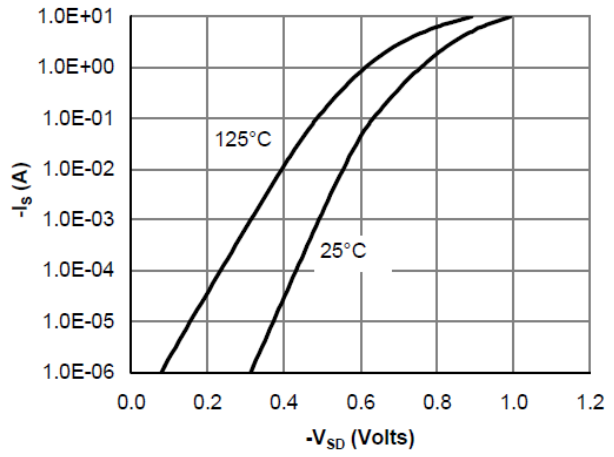

Figure 6: Body-Diode Characteristics

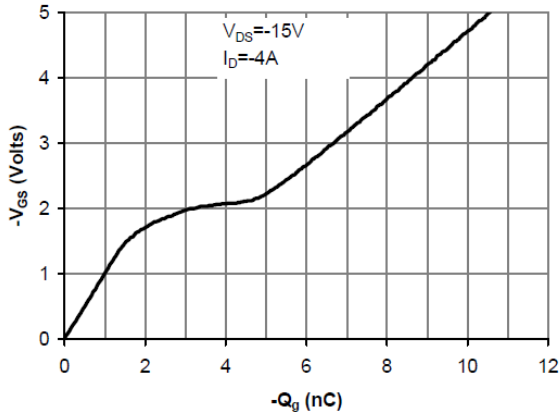

Figure 7: Gate-Charge Characteristics

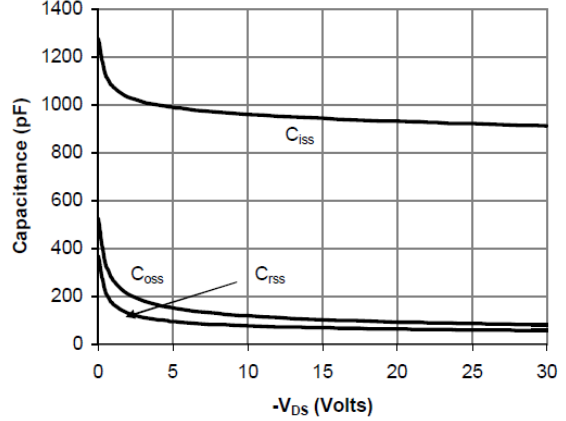

Figure 8: Capacitance Characteristics

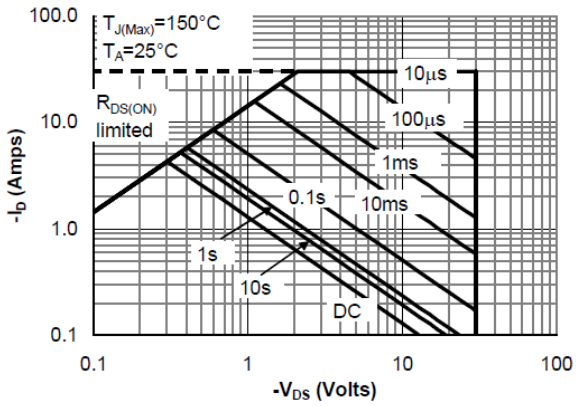

Figure 9: Maximum Forward Biased Safe Operating Area (Note E)

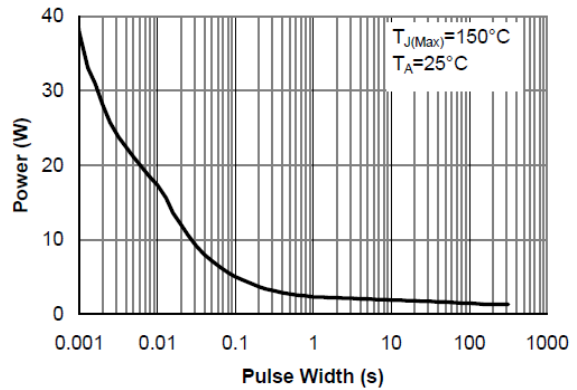

Figure 10: Single Pulse Power Rating Junction-to-Ambient (Note E)

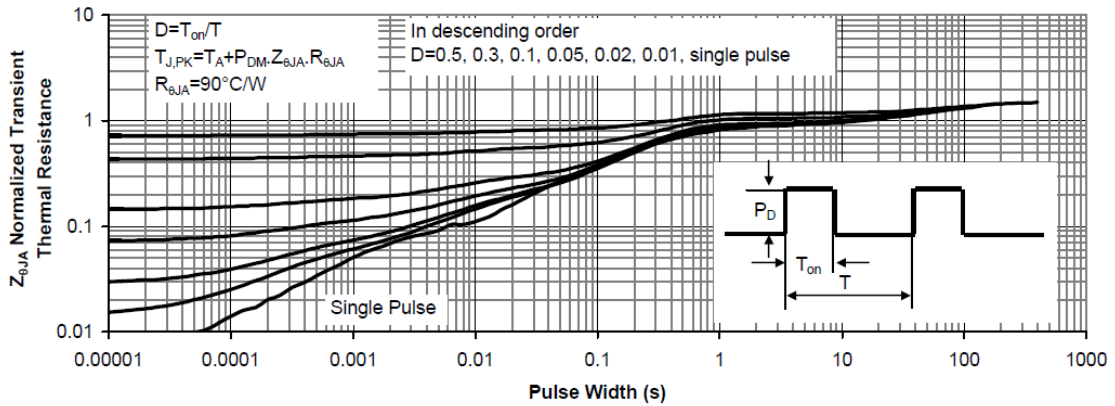
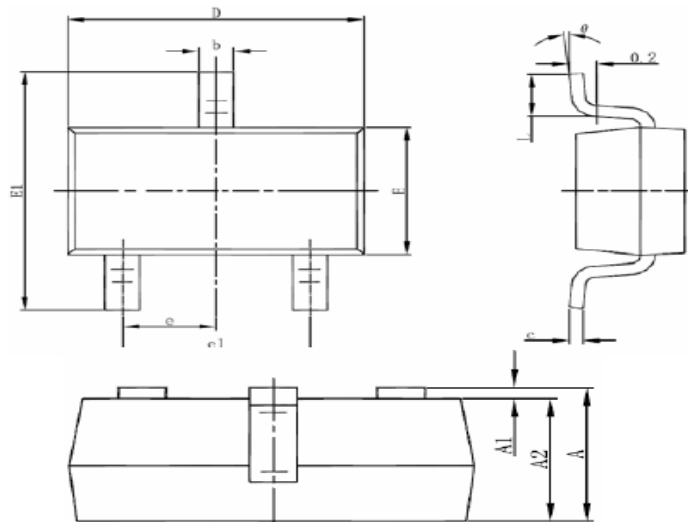

Figure 11: Normalized Maximum Transient Thermal Impedance

SOT-23-3L Package Information



Symbol	Dimensions In Millimeters		Dimensions In Inches	
	Min	Max	Min	Max
A	1.050	1.250	0.041	0.049
A1	0.000	0.100	0.000	0.004
A2	1.050	1.150	0.041	0.045
b	0.300	0.500	0.012	0.020
c	0.100	0.200	0.004	0.008
D	2.820	3.020	0.111	0.119
E	1.500	1.700	0.059	0.067
E1	2.650	2.950	0.104	0.116
e	0.950(BSC)		0.037(BSC)	
e1	1.800	2.000	0.071	0.079
L	0.300	0.600	0.012	0.024
θ	0°	8°	0°	8°

The SINO-IC logo is a registered trademark of Shanghai Sino-IC Microelectronics Co., Ltd.

© 2005 SINO-IC – Printed in China – All rights reserved.

SHANGHAI SINO-IC MICROELECTRONICS CO., LTD

Add: Building 3, Room 3401-03, No.200 Zhangheng Road, ZhangJiang Hi-Tech Park, Pudong, Shanghai 201203, China

Phone: +86-21-33932402 33932403 33932405 33933508 33933608

Fax: +86-21-33932401

Email: webmaster@sino-ic.com

Website: <http://www.sino-ic.com>