

Description

The AR0502S1 is a 2-line ultra-low capacitance TVS diode array, utilizing leading monolithic silicon technology to provide fast response time and low ESD clamping voltage, making this device an ideal solution for protecting voltage sensitive high-speed data lines. The AR0502S1 has a very low capacitance with a typical value at 0.3pF, and complies with the IEC 61000-4-2 (ESD) with $\pm 25\text{kV}$ air and $\pm 20\text{kV}$ contact discharge. It is assembled into a 4-pin SOT-143 lead-free package. The small size, very low capacitance and high ESD surge protection make AR0502S1 an ideal choice to protect cell phone, digital video interfaces, high speed data ports, and many other portable applications.

Features

- Ultra low capacitance: 0.3pF typical
- Ultra low leakage: nA level
- Operating voltage: 5V
- Low clamping voltage
- 4-pin SOT-143 package
- Protects two data lines and one power line
- Complies with following standards:
 - IEC 61000-4-2 (ESD) immunity test
Air discharge: $\pm 25\text{kV}$
Contact discharge: $\pm 20\text{kV}$
 - IEC61000-4-5 (Lightning) 5A (8/20 μs)
- RoHS Compliant

Mechanical Characteristics

- Package: SOT-143
- Lead Finish: Matte Tin
- Case Material: “Green” Molding Compound.
- Moisture Sensitivity: Level 3 per J-STD-020
- Terminal Connections: See Diagram Below
- Marking Information: See Below

Applications

- Cellular Handsets and Accessories
- Notebooks and Handhelds
- Personal Digital Assistants
- Portable Instrumentation
- Digital Cameras
- Peripherals
- Audio Players, Keypads, Side Keys, LCD
- USB 2.0

Marking Information

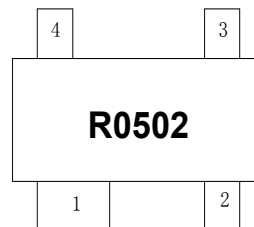

R0502 = Device Marking Code
Pin1 is ground

Dimensions and Pin Configuration

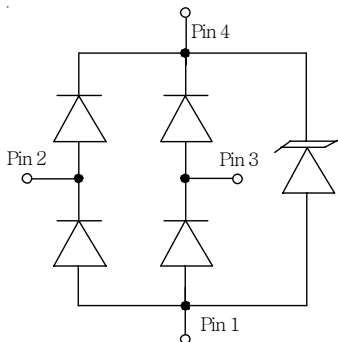

Circuit Diagram

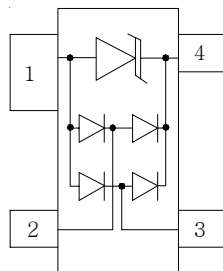

Pin Schematic

Ordering Information

Part Number	Packaging	Reel Size
AR0502S1	3000/Tape & Reel	7 inch

Absolute Maximum Ratings ($T_A=25^{\circ}\text{C}$ unless otherwise specified)

Parameter	Symbol	Value	Unit
Peak Pulse Power (8/20 μs)	Ppk	75	W
Peak Pulse Current (8/20 μs)	I _{PP}	5	A
ESD per IEC 61000-4-2 (Air)	V _{ESD}	± 25	kV
ESD per IEC 61000-4-2 (Contact)		± 20	
Operating Temperature Range	T _J	-55 to +125	$^{\circ}\text{C}$
Storage Temperature Range	T _{stg}	-55 to +150	$^{\circ}\text{C}$

Electrical Characteristics ($T_A=25^{\circ}\text{C}$ unless otherwise specified)

Parameter	Symbol	Min	Typ	Max	Unit	Test Condition
Reverse Working Voltage	V _{RWM}			5	V	Any I/O pin to ground
Breakdown Voltage	V _{BR}	6			V	I _T = 1mA, any I/O pin to ground
Reverse Leakage Current	I _R			0.5	μA	V _{RWM} = 5V, any I/O pin to ground
Clamping Voltage	V _C			10	V	I _{PP} = 1A (8 x 20 μs pulse), any I/O pin to ground
Clamping Voltage	V _C			15	V	I _{PP} = 5A (8 x 20 μs pulse), any I/O pin to ground
Junction Capacitance	C _J		0.3	0.4	pF	V _R = 0V, f = 1MHz, between I/O pins
Junction Capacitance	C _J			0.8	pF	V _R = 0V, f = 1MHz, any I/O pin to ground

Note 1: I/O pins are pin 2 & 3

Typical Performance Characteristics ($T_A=25^\circ\text{C}$ unless otherwise Specified)

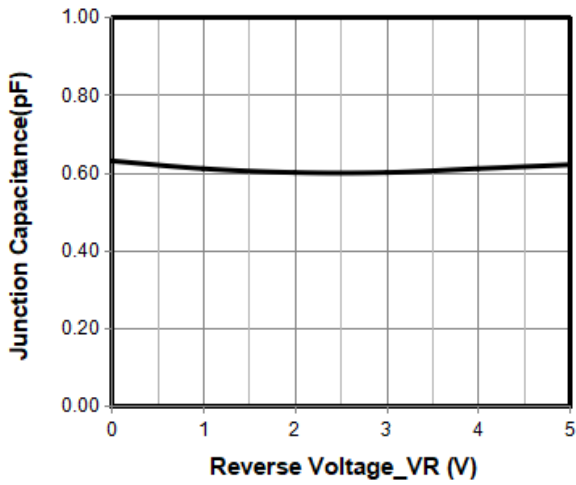

Junction Capacitance vs. Reverse Voltage

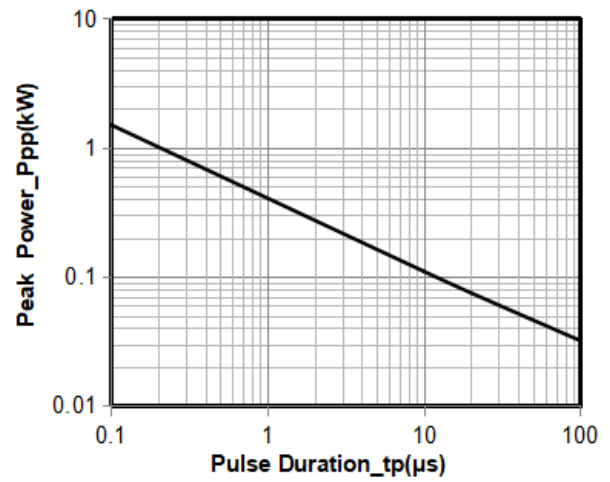

Peak Pulse Power vs. Pulse Time

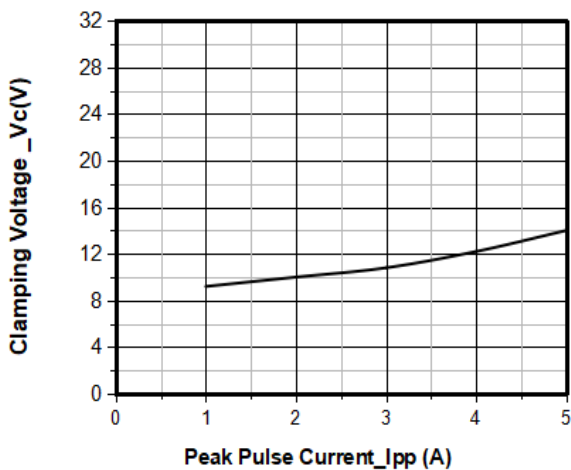

Clamping Voltage vs. Peak Pulse Current

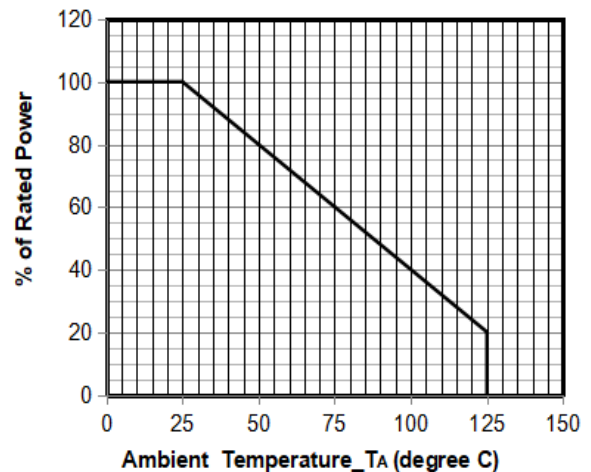

Power Derating Curve

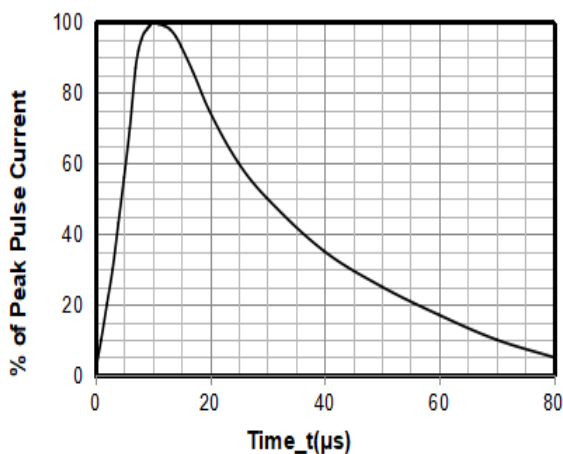

8 X 20 μs Pulse Waveform

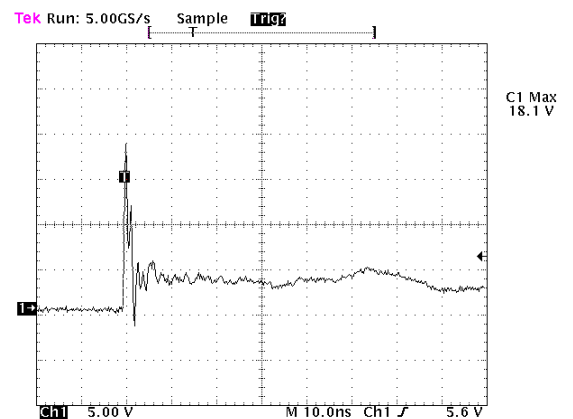

Note: Data is taken with a 10x attenuator

ESD Clamping Voltage

8 kV Contact per IEC61000-4-2

AR0502S1 on USB Port Application

The AR0502S1 can be used to protect the USB port on the monitors, computers, peripherals or portable systems. The ESD protection scheme for single USB ports is shown below figure, the voltage bus (VBUS) of USB port is connected to the power pin (pin4) of AR0502S1. Each data line (D+/D-) of USB port is connected to the ESD protection pin (pin2/pin3) of AR0502S1. When ESD voltage pulse appears on the data line, the ESD pulse current will be conducted by AR0502S1 away from the USB controller chip. In addition, the ESD pulse current also can be conducted by AR0502S1 away from the USB controller chip when the ESD voltage pulse appears on the voltage bus (VBUS) of USB port. Therefore, the data lines (D+/D-) and voltage bus (VBUS) of two USB ports are complementally protected with one AR0502S1.

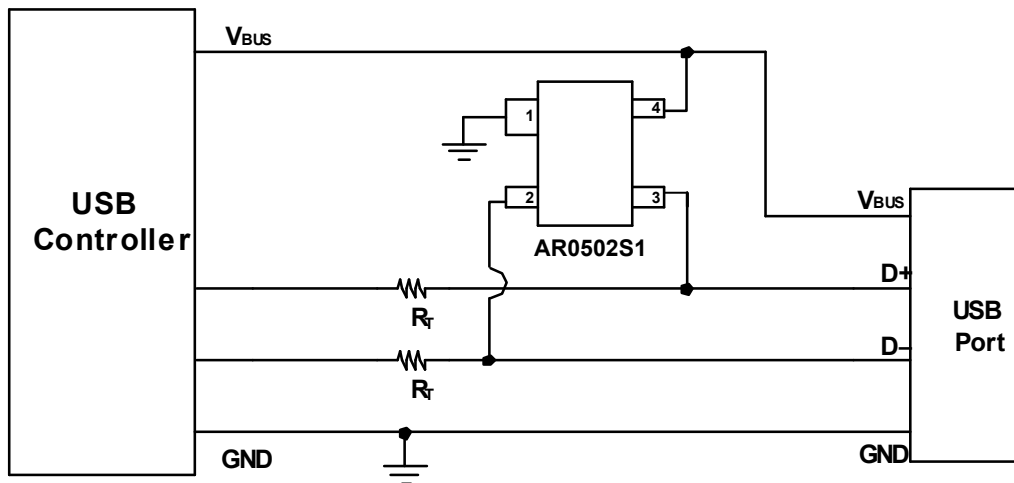

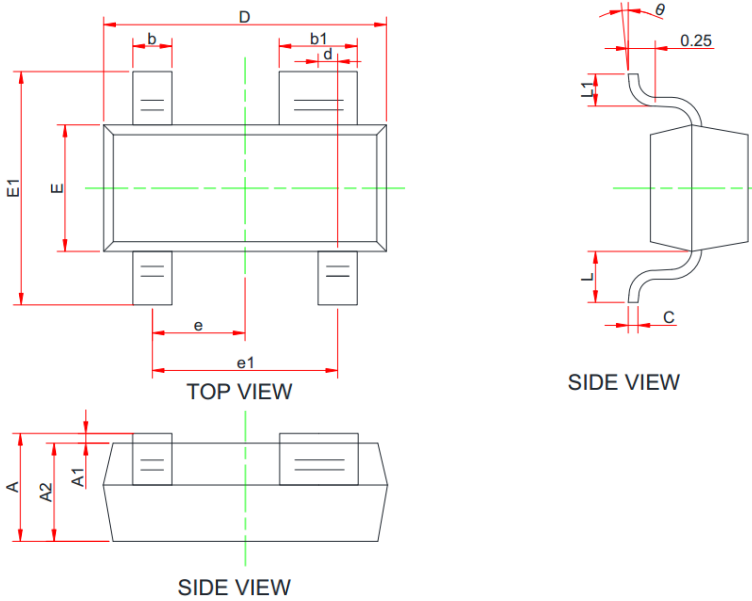
SOT-143 Package Outline Drawing

SYS YM	MILLIMETERS		
	MIN	NOM	MAX
A	0.90	-	1.15
A1	0.00	0.05	0.10
A2	0.90	-	1.05
b	0.30	0.40	0.50
b1	0.75	-	0.90
c	0.08	-	0.15
D	2.80	2.90	3.00
d	0.20 Typ		
E	1.20	1.30	1.40
E1	2.25	2.40	2.55
e	0.95 Typ		
e1	1.80	1.90	2.00
L	0.55 Ref		
L1	0.30	0.40	0.50
Θ	0°	-	8°

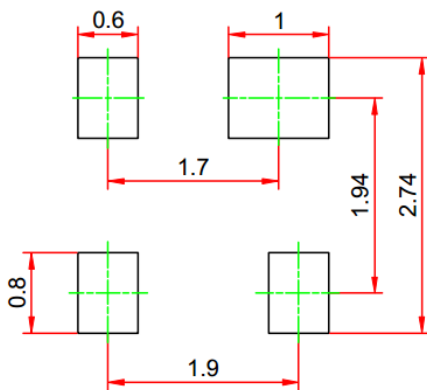
Suggested Land Pattern

Unit(mm)

Contact Information

Applied Power Microelectronics Co., Ltd.

 Website: <http://www.appliedpowermicro.com>

 Email: sales@appliedpowermicro.com

Phone: +86 (0519) 8399 3606