

GENERAL DESCRIPTION

The SGM41000 is designed for small Li+ or Li-Poly rechargeable cells. This device has all circuits that are typically used in battery protection, including charging and discharging switches, detection and protection to over-charging, over-discharging and over-current, empty or battery under-voltage pre-charging, and shutdown circuit for deep discharging.

The SGM41000 is designed to operate in -40°C to +85°C temperature range, is in thin UTDFN-1.5×2-6L, nominal height 0.5mm package that is convenient to small cell packing designs.

FEATURES

- **Unique Monolithic Design for Small Cells**
- **Ultra Compact Solution**
- **95mΩ Pass Resistance**
- **Factory Programmable OVP Threshold**
4.15V to 4.45V in 50mV Steps
- **Discharge Over-Current Protection**
- **Over-Discharging Protection**
- **Battery Under-Voltage Pre-Charging**
- **Deep Discharging Shutdown**
- **0V Battery Charging**
- **Internal Input Voltage Surge Clamping**
- **Flexible Wake-Up from Protection or Sleep**
- **Available in Green UTDFN-1.5×2-6L Package**

APPLICATIONS

IoT Gadgets
Wearable Devices

TYPICAL APPLICATION

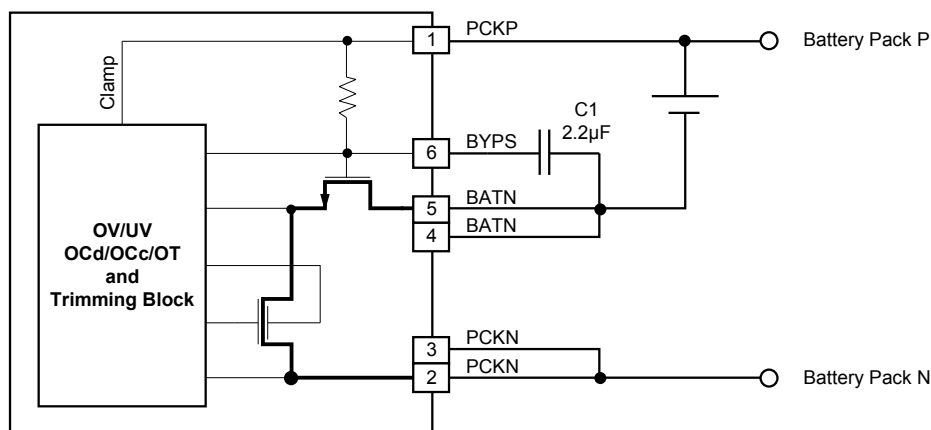

Figure 1. Typical Application Circuit

PACKAGE/ORDERING INFORMATION

MODEL	PACKAGE DESCRIPTION	SPECIFIED TEMPERATURE RANGE	ORDERING NUMBER	PACKAGE MARKING	PACKING OPTION
SGM41000	UTDFN-1.5×2-6L	-40°C to +85°C	SGM41000-4.2YUDT6G/TR	GG9 XXX	Tape and Reel, 3000
	UTDFN-1.5×2-6L	-40°C to +85°C	SGM41000-4.25YUDT6G/TR	GF5 XXX	Tape and Reel, 3000
	UTDFN-1.5×2-6L	-40°C to +85°C	SGM41000-4.3YUDT6G/TR	GF6 XXX	Tape and Reel, 3000
	UTDFN-1.5×2-6L	-40°C to +85°C	SGM41000-4.35YUDT6G/TR	G50 XXX	Tape and Reel, 3000
	UTDFN-1.5×2-6L	-40°C to +85°C	SGM41000-4.45YUDT6G/TR	G77 XXX	Tape and Reel, 3000
	UTDFN-1.5×2-6L	-40°C to +85°C	SGM41000A-4.35YUDT6G/TR	G91 XXX	Tape and Reel, 3000
	UTDFN-1.5×2-6L	-40°C to +85°C	SGM41000A-4.45YUDT6G/TR	G92 XXX	Tape and Reel, 3000
	UTDFN-1.5×2-6L	-40°C to +85°C	SGM41000B-4.35YUDT6G/TR	G93 XXX	Tape and Reel, 3000
	UTDFN-1.5×2-6L	-40°C to +85°C	SGM41000B-4.45YUDT6G/TR	G94 XXX	Tape and Reel, 3000
	UTDFN-1.5×2-6L	-40°C to +85°C	SGM41000C-4.3YUDT6G/TR	G13 XXX	Tape and Reel, 3000
	UTDFN-1.5×2-6L	-40°C to +85°C	SGM41000C-4.35YUDT6G/TR	GDD XXX	Tape and Reel, 3000
	UTDFN-1.5×2-6L	-40°C to +85°C	SGM41000C-4.45YUDT6G/TR	GDE XXX	Tape and Reel, 3000
	UTDFN-1.5×2-6L	-40°C to +85°C	SGM41000-4.3HYUDT6G/TR	GMF XXX	Tape and Reel, 3000
	UTDFN-1.5×2-6L	-40°C to +85°C	SGM41000-4.35HYUDT6G/TR	GN0 XXX	Tape and Reel, 3000
	UTDFN-1.5×2-6L	-40°C to +85°C	SGM41000-4.45HYUDT6G/TR	GN1 XXX	Tape and Reel, 3000
	UTDFN-1.5×2-6L	-40°C to +85°C	SGM41000C-4.3HYUDT6G/TR	GN2 XXX	Tape and Reel, 3000
	UTDFN-1.5×2-6L	-40°C to +85°C	SGM41000C-4.35HYUDT6G/TR	GN3 XXX	Tape and Reel, 3000
	UTDFN-1.5×2-6L	-40°C to +85°C	SGM41000C-4.45HYUDT6G/TR	GN4 XXX	Tape and Reel, 3000

NOTE: XXX = Date Code.

Green (RoHS & HSF): SG Micro Corp defines "Green" to mean Pb-Free (RoHS compatible) and free of halogen substances. If you have additional comments or questions, please contact your SGMICRO representative directly.

True Monolithic Li+/Li-Poly Battery Protector Full Functions in Tiny Thin Package

SGM41000

ABSOLUTE MAXIMUM RATINGS

PCKP-PCKN, 10.5V or 1A Surge Clamping.....	5s
PCKP-PCKN, Continuous.....	9V
Junction Temperature.....	+150°C
Storage Temperature Range.....	-65°C to +150°C
Lead Temperature (Soldering 10 sec).....	+260°C
ESD Susceptibility	
HBM.....	2000V
MM.....	200V
CDM.....	1000V

RECOMMENDED OPERATING CONDITIONS

Supply Voltage Range.....	0V to 8V
Battery Voltage Range.....	2.6V to 4.5V
Charging Current (I_{CHG}).....	~250mA
Discharging Current (I_{DIS}).....	~350mA
Environmental Temperature Range.....	-40°C to +85°C

OVERSTRESS CAUTION

Stresses beyond those listed may cause permanent damage to the device. Functional operation of the device at these or any other conditions beyond those indicated in the operational section of the specification is not implied. Exposure to absolute maximum rating conditions for extended periods may affect reliability.

ESD SENSITIVITY CAUTION

This integrated circuit can be damaged by ESD if you don't pay attention to ESD protection. SGMICRO recommends that all integrated circuits be handled with appropriate precautions. Failure to observe proper handling and installation procedures can cause damage. ESD damage can range from subtle performance degradation to complete device failure. Precision integrated circuits may be more susceptible to damage because very small parametric changes could cause the device not to meet its published specifications.

DISCLAIMER

SG Micro Corp reserves the right to make any change in circuit design, specification or other related things if necessary without notice at any time.

PIN CONFIGURATION

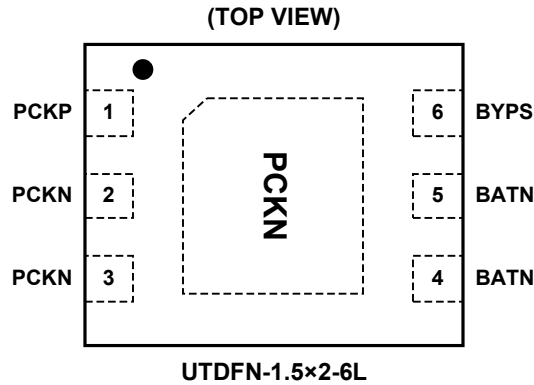

PIN DESCRIPTION

PIN	NAME	TYPE	FUNCTION
1	PCKP	P	Power Input. Connect to battery pack anode terminal.
2	PCKN	P	Battery Switch Pole. Connect to battery pack cathode terminal.
3	PCKN	P	Battery Switch Pole. Connect to battery pack cathode terminal.
4	BATN	G	Ground.
5	BATN	G	Ground.
6	BYPS	IO	Bypass Pin. Place a 2.2μF capacitor between this pin and BATN pin.

NOTE: IO: input or output; G: ground; P: power for the circuit.

ELECTRICAL CHARACTERISTICS(T_A = +25°C, V_{PCKP} = 5V, I_{CHG} = I_{DIS} = 100mA, V_{BAT} = 3.5V, unless otherwise noted.)

PARAMETER	SYMBOL	CONDITIONS	MIN	TYP	MAX	UNITS
Over-Voltage Threshold	V _{OV}	SGM41000-4.2	4.158	4.2	4.242	V
		SGM41000-4.25	4.208	4.25	4.292	
		SGM41000-4.3	4.258	4.3	4.342	
		SGM41000-4.35	4.308	4.35	4.392	
		SGM41000-4.45	4.408	4.45	4.492	
		SGM41000-4.3H	4.258	4.3	4.342	
		SGM41000-4.35H	4.308	4.35	4.392	
		SGM41000-4.45H	4.408	4.45	4.492	
OV Release Hysteresis	V _{OVHYS}			-100		mV
Under-Voltage Threshold	V _{UV}	SGM41000, SGM41000A, SGM41000B, SGM41000C	2.43	2.5	2.57	V
		SGM41000-H, SGM41000C-H	2.93	3	3.07	
UV Release Hysteresis	V _{UVHYS}	SGM41000, SGM41000A, SGM41000B, SGM41000C		110		mV
		SGM41000-H, SGM41000C-H		135		
Shutdown Voltage	V _{SHDN}			1.67		V
Over-Discharge Current	I _{OD}	SGM41000, any V _{OV}	370	650	1130	mA
		SGM41000A, any V _{OV}	800	1210	2000	
		SGM41000B, any V _{OV}	1480	2180	3230	
		SGM41000C, any V _{OV}	130	380	500	
		SGM41000-H, any V _{OV}	370	650	1130	
		SGM41000C-H, any V _{OV}	130	380	500	
Over-Charge Current	I _{OC}	SGM41000, any V _{OV}	230	370	570	mA
		SGM41000A, any V _{OV}	360	650	1090	
		SGM41000B, any V _{OV}	740	1200	1910	
		SGM41000C, any V _{OV}	100	240	380	
		SGM41000-H, any V _{OV}	230	370	570	
		SGM41000C-H, any V _{OV}	100	240	380	
Pass Resistance	R _P			95	130	mΩ
Operation Current	I _{OP}			1.6	2.2	μA
Shutdown Current	I _{SHDN}				0.3	μA
Clamp Voltage	V _{CLAMP}	V _{BAT} = 4.6V, I _{CLAMP} = 1mA		6.44		V
Over-Voltage Detection Delay	t _{OVPD}			1		s
Under-Voltage Detection Delay	t _{UVPD}			130		ms
Over-Discharge Current Detection Delay	t _{ODD}			130		μs
Over-Discharge Current Retry Time	t _{RETRY}			130		ms
Over-Charge Current Detection Delay	t _{OCD}			8		ms

TYPICAL PERFORMANCE CHARACTERISTICS

T_A = +25°C, V_{PCKP} = 5V, V_{BAT} = 3.5V, unless otherwise specified.

Pass Resistance vs. Battery Voltage

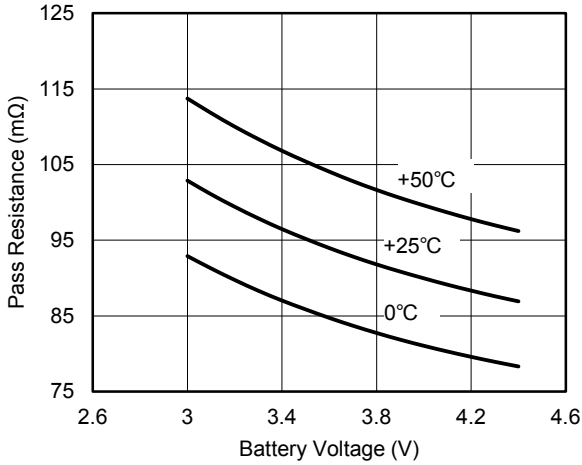

Clamp Current vs. Applied Voltage

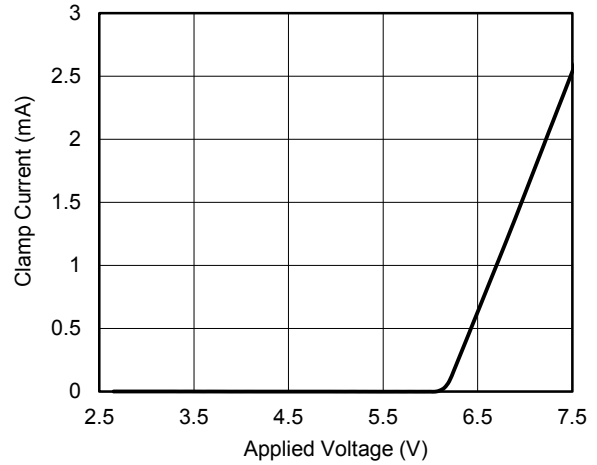

Over-Voltage Threshold Distribution

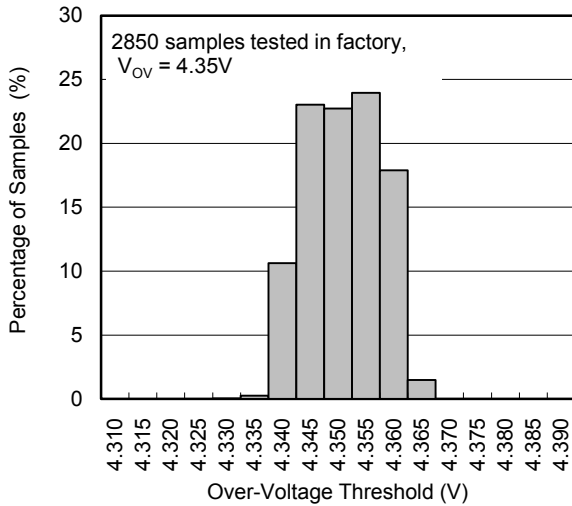

TYPICAL PERFORMANCE CHARACTERISTICS (continued)

T_A = +25°C, V_{PCKP} = 5V, V_{BAT} = 3.5V, unless otherwise specified.

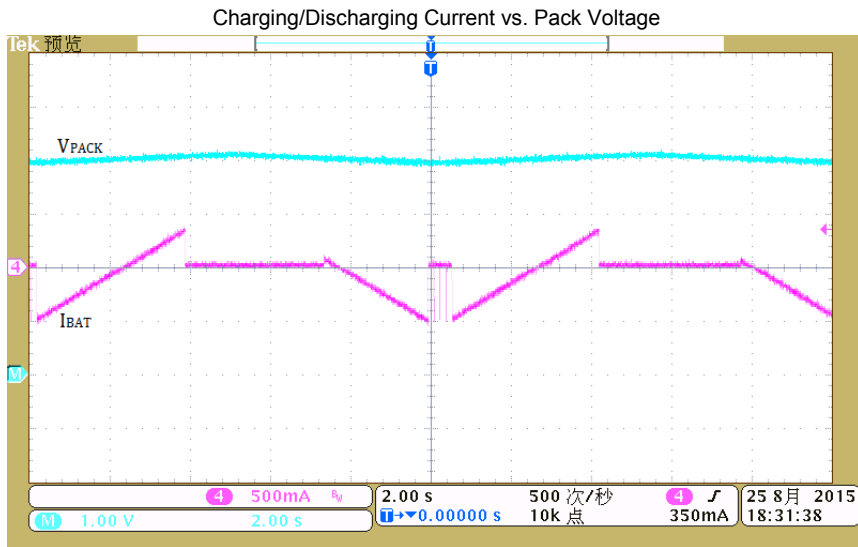
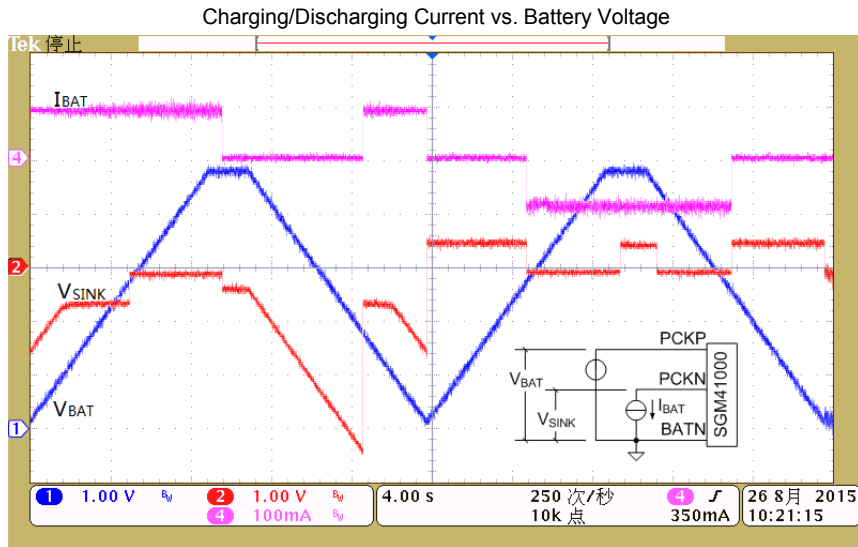

FUNCTION DESCRIPTION

This part monitors voltage and current applied on battery cell connected between PCKP and BATN, and breaks the connection between battery and pack terminal with its internal switches when abnormality is identified.

Voltage Related Protections

When battery voltage reaches over-voltage threshold, charging path is broken with its internal switch. The switch closes again when battery voltage falls back about 100mV below the threshold, or discharging happens.

When battery voltage goes below about 2.5V/3V, internal discharging path switch opens, to protect the battery from over discharged. If battery voltage goes low further, at about 1.67V, this IC is turned into shutdown for further reducing current consumption, which helps keeping battery from harmful exhausted condition as long as possible. The switch closes again when the charger is connected and battery voltage rise to about 110mV/135mV above the threshold.

Charging a zero-voltage battery: The discharging switch does not break the charging path even when battery is low as zero-voltage. A poorly discharged battery or even a zero-voltage battery is still can be charged through the path switches in this IC. The charging current before pack voltage goes higher than about 2.5V/3V is limited by pre-charging current applied externally and by an internal forward diode.

Current Related Protections

When over-discharging current for over about 130μs is detected, the output path opens. The switch is turned on again in about 130ms for retrieval, which is repeated until over-current condition released to battery voltage turns low enough into under-voltage protection.

When over-charging current is identified, charging path is broken and it is restored when pack voltage drops close to battery voltage in range about 30mV.

Surge and ESD Absorption

A shunt regulation structure with a serial resistance around 500Ω is built and a repeatable avalanche breaking between PCKP and PCKN are designed for surge absorption, which may happen when inserting a pack into a powered system. When a battery loads a system with pairs of long wires or an inductive load, or a cell may attach terminals reversely, a 499Ω resistor inserted into PCKP connection, i.e., the R1 in circuit showed in Figure 2, prevents the circuit from possible damage by reverse bias.

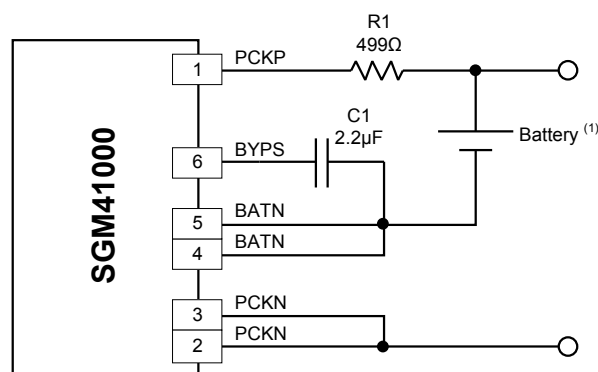

NOTE:

1. The battery pack P/N should not add E-load or short-circuit before the battery is connected to the circuit, or IC cannot start, and damage to the device.

Figure 2. Inductive Load Breaking and Battery Reversing Protection Option with R1 Added

ESD absorbing cells are built to protect the chip in carrying and assembly. ESD susceptibility of a pack assembly is highly dependent on charge discharging path and in most cases, is higher than the IC's. Characterization with final pack design is recommended.

Activation from Shutdown

When a battery connects into the protection circuit or battery voltage goes low enough, the protection circuit turns into shutdown for preventing from discharging through the protection circuit, where it does not connect the cell to power external load until once an external charging voltage applied regardless what cell voltage is. To start with a newly assembled battery pack, applying a charging voltage or bypassing BATN-PCKN switch once with external conducting is needed.

REVISION HISTORY

NOTE: Page numbers for previous revisions may differ from page numbers in the current version.

MAY 2017 – REV.A to REV.A.1

Added SGM41000-H part numberAll

Changes from Original (SEPTEMBER 2016) to REV.A

Changed from product preview to production data.....All

PACKAGE OUTLINE DIMENSIONS

UTDFN-1.5×2-6L

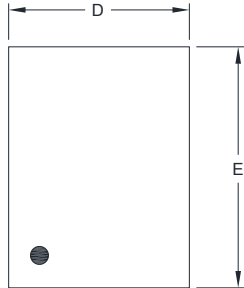

TOP VIEW

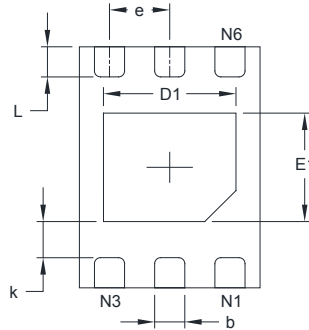

BOTTOM VIEW

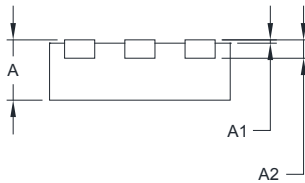

SIDE VIEW

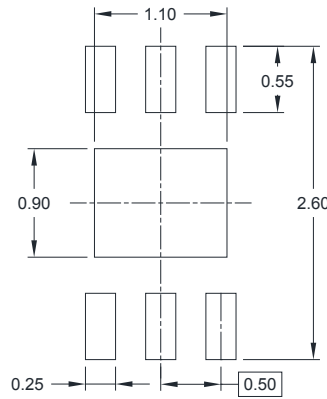

RECOMMENDED LAND PATTERN (Unit: mm)

Symbol	Dimensions In Millimeters		Dimensions In Inches	
	MIN	MAX	MIN	MAX
A	0.450	0.550	0.018	0.022
A1	0.000	0.050	0.000	0.002
A2	0.152 REF		0.006 REF	
D	1.400	1.600	0.055	0.063
D1	1.000	1.200	0.039	0.047
E	1.900	2.100	0.075	0.083
E1	0.800	1.000	0.031	0.039
k	0.200 MIN		0.008 MIN	
b	0.200	0.300	0.008	0.012
e	0.500 TYP		0.020 TYP	
L	0.200	0.300	0.008	0.012

PACKAGE INFORMATION

TAPE AND REEL INFORMATION

REEL DIMENSIONS



TAPE DIMENSIONS



NOTE: The picture is only for reference. Please make the object as the standard.

KEY PARAMETER LIST OF TAPE AND REEL

Package Type	Reel Diameter	Reel Width W1 (mm)	A0 (mm)	B0 (mm)	K0 (mm)	P0 (mm)	P1 (mm)	P2 (mm)	W (mm)	Pin1 Quadrant
UTDFN-1.5×2-6L	7"	9.5	1.70	2.30	0.75	4.0	4.0	2.0	8.0	Q2

000001

PACKAGE INFORMATION

CARTON BOX DIMENSIONS



NOTE: The picture is only for reference. Please make the object as the standard.

KEY PARAMETER LIST OF CARTON BOX

Reel Type	Length (mm)	Width (mm)	Height (mm)	Pizza/Carton
7" (Option)	368	227	224	8
7"	442	410	224	18

DD0002