

12 mΩ Power Switch with Current Limit and Charging Port Controller

1 DESCRIPTION

The SC7004 is a power switch which integrates an ultra-low R_{dson} (12mΩ) N-channel MOSFET. It is designed for USB port applications or other applications which require high current switch. It provides current limit function, and the current limit can be programmable through an external resistor. The SC7004 also integrates USB charging port controller function. It can support traditional type A USB port with DP and DM signals. It monitors the DP/DM data line voltage, and automatically supports the DCP schemes for Battery Charging specification (BC1.2), the divider Mode and 1.2V/1.2V Mode.

The SC7004 also supports various protections, including over voltage protection, under voltage protection, short circuit protection, and thermal shutdown protection.

The SC7004 requires a minimum number of external components to complete USB switch and charging port solution. It is available in TSOT23-8 package.

3 APPLICATIONS

- USB chargers
- USB HUB
- USB power supplies
- USB peripherals

2 FEATURES

- 12mΩ Ultra-low R_{dson} NMOS Switch
- Programmable Current Limit
- ± 5% Current Limit Accuracy at 2.7A
- Built-in Soft-Start
- Ultra-low Operation Current
- Status Indication
 - ✓ Device Removal Indication
 - ✓ Short Circuit Fault Indication
- USB Charging Port Controller Function
 - ✓ Battery Charging specification BC1.2 for DCP
 - ✓ Chinese telecommunication industrial standard YD/T 1591-2009
 - ✓ D+/D- option for Apple device (2.4A)
 - ✓ D+/D- option for Samsung device
- Input Under Voltage Protection
- Input Over Voltage Protection
- Over Current Protection
- Short Circuit Protection
- Thermal Shutdown Protection
- ±8kV HBM ESD Rating for USB IO pins
- TSOT23-8 package

4 ORDERING INFORMATION

Part Number	Package	Dimension
SC7004SAER	TSOT23-8	2.92*2.8*0.95 mm

5 Typical Application Circuit

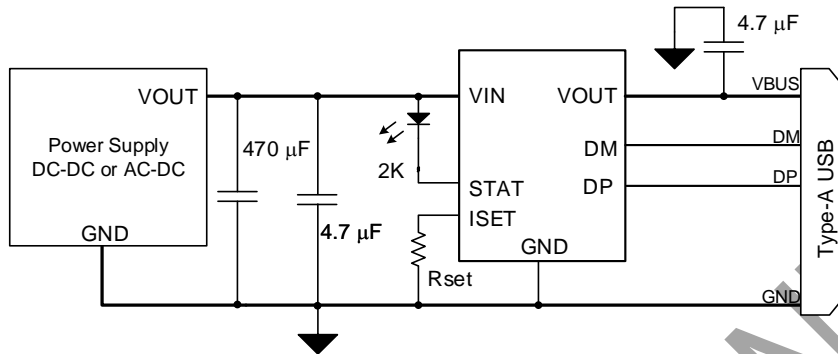

Figure 1 SC7004 typical application circuit

6 Pin Configurations and Functions

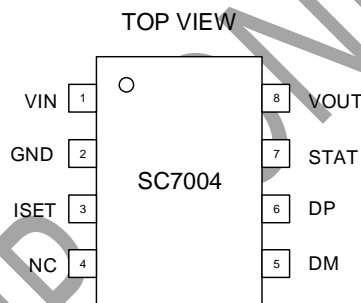

Table 1 Pin description

Terminals	NAME	I/O	Description
1	VIN	I	Input to the switch
2	GND	IO	Ground
3	ISET	I	Set the current limit value
4	NC	-	Not connected
5	DM	IO	DM pin for type A USB port interface
6	DP	IO	DP pin for type A USB port interface
7	STAT	O	Open drain output. Connect an LED from VIN pin to STAT pin for status indication. It is internally pulled low to indicate the port is active.
8	VOUT	O	Output of the switch

7 Electrical Specifications

7.1 Absolute Maximum Ratings

over operating free-air temperature range (unless otherwise noted)⁽¹⁾

		Min.	Max.	Unit
Voltage ⁽²⁾	VIN, VOUT, STAT	-0.3	7	V
	DP, DM	-0.3	VIN+0.3V or 5.7V	V
	ISET	-0.3	5.5	V
T _J	Operating junction temperature	-40	150	°C
T _{stg}	Storage temperature	-65	150	°C
T _L	Lead Temperature		260	°C
T _D	Continuous power dissipation (TA=25°C)		1.25	W
T _{θJA} ⁽³⁾	Junction to ambient thermal resistance	100		°C/W
T _{θJC} ⁽³⁾	Junction to case thermal resistance	12		°C/W

(1) Stresses beyond those listed under absolute maximum ratings may cause permanent damage to the device.

(2) All voltages are with respect to network ground terminal.

(3) Measured on JESD51-7, 4-layer PCB.

7.2 ESD Ratings

		Min.	Max.	Unit	
V _{ESD} ⁽¹⁾	Human-body Model (HBM) ⁽²⁾	All pins except DP / DM	-4	4	kV
		DP / DM	-8	8	kV
	Charged-device Model (CDM) ⁽³⁾	-1000	1000	V	

(1) Electrostatic discharge (ESD) to measure device sensitivity and immunity to damage caused by assembly line electrostatic discharges into the device.

(2) Level listed above is the passing level per ANSI, ESDA, and JEDEC JS-001. JEDEC document JEP155 states that 500-V HBM allows safe manufacturing with a standard ESD control process.

(3) Level listed above is the passing level per EIA-JEDEC JESD22-C101. JEDEC document JEP157 states that 250-V CDM allows safe manufacturing with a standard ESD control process.

7.3 Recommended Operation Conditions

		Min.	Typ.	Max.	Unit
V _{IN}	VIN voltage range	4	5	5.6	V
C _{IN}	VIN capacitor	4.7			μF
C _{OUT}	VOUT capacitor	3.3		22	μF
T _A	Operating ambient temperature	-40		85	°C
T _J	Operating junction temperature	-40		125	°C

7.4 Electrical Characteristics

$T_J = 25^\circ\text{C}$ and $V_{IN} = 5\text{V}$ and $V_{OUT} = 5\text{V}$ unless otherwise noted.

PARAMETER	TEST CONDITIONS	MIN	TYP	MAX	UNIT		
SUPPLY VOLTAGE							
V_{IN}	Operating voltage	4		5.6	V		
V_{IN_UVLO}	Under voltage lockout threshold	Rising	3.7	3.8	3.9	V	
		Hysteresis	0.5	0.6	0.7	V	
I_Q	Quiescent current	VIN=5V, No load		60	92	120	μA
POWER FET							
R_{DS_ON}	Rdson of switch	VIN=5V		12			m Ω
T_{SS}	Soft start time	VIN = 5V, turning on, no load		1			ms
		VIN = 5V, turning on, IOU = 3A		1.5			ms
CURRENT LIMIT							
V_{REF}	Reference voltage	1.176	1.2	1.224			V
I_{LIM}	Current limit accuracy	$R_{ISET} = 150\text{K}\Omega$		2.65	2.75	2.88	A
STATUS INDICATION							
I_{ACT_TH}	Active current detection threshold	Falling	25	50	75		mA
		Hysteresis	1		7		mA
I_{STAT}	STAT pin sink current	VSTAT = 0.4 V		3	4	5	mA
PROTECTION							
V_{IN_OVP}	VIN OVP protection	Rising edge, over V_{OUT} , $V_{OUT} = 5\text{V}$	5.6	5.8	6		V
		Falling edge	5.5	5.7	5.9		V
I_{ML}	Maximum current limit	$R_{ISET} = 0$		5.5			A
V_{SC_th}	VOU short circuit protection threshold	3.4	3.6	3.8			V
T_{HIC_ON}	OCP on time of hiccup	VOU < 1.1V		3			ms
T_{HIC_OFF}	OCP off time of hiccup		0.5				s
TSD	Thermal shutdown temperature threshold	Not in current limit		150			$^\circ\text{C}$
		In current limit		140			$^\circ\text{C}$
	Thermal shutdown hysteresis	Thermal shutdown hysteresis		25			$^\circ\text{C}$
DP/DM LOGIC							
$V_{DP_2P75_SRC}$	DP source 2.75V voltage	VIN=5V		2.57	2.75	2.84	V
$V_{DM_2P75_SRC}$	DM source 2.75V voltage	VIN=5V		2.57	2.75	2.84	V
Z_{DP/M_2P75}	DP/DM pin output impedance for 2.75V output	24	30	36			K Ω
Z_{DP/M_1P2}	DP/DM pin output impedance for 1.2V output	70	100	130			K Ω
V_{DP/DM_1P2_SRC}	DP/DM source 1.2V voltage	1.1	1.2	1.3			V
R_{DP/DM_short}	DP and DM short circuit switch	5	10	20			Ω

7.5 Typical Characteristics

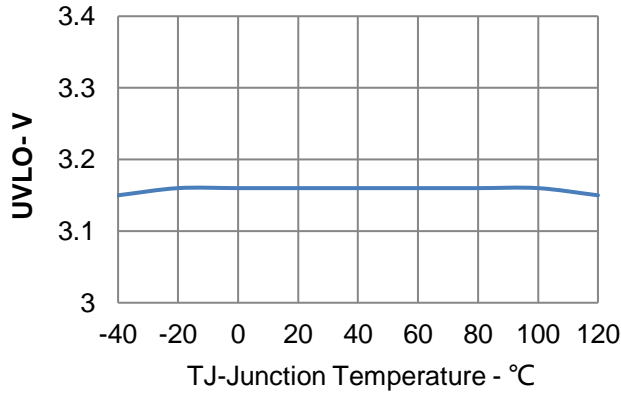

Figure 2 Under Voltage Lock Output VS. Temperature

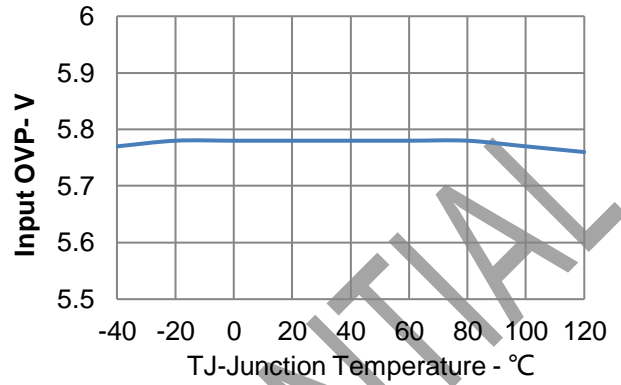

Figure 3 Input Over Voltage Protection VS. Temperature

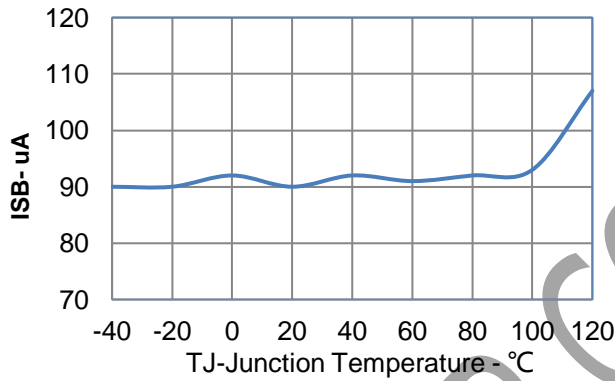

Figure 4 Standby Current (VIN=5V) VS. Temperature

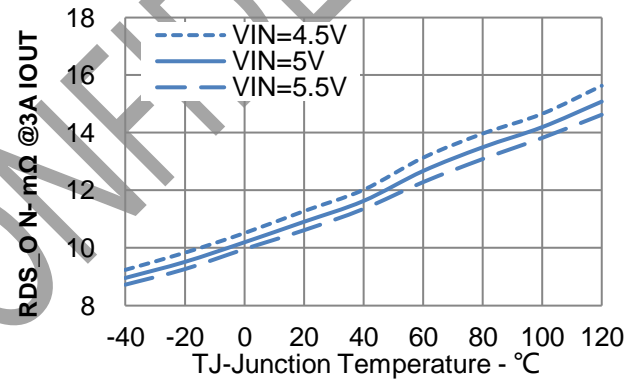

Figure 5 ON-Resistance VS. Temperature

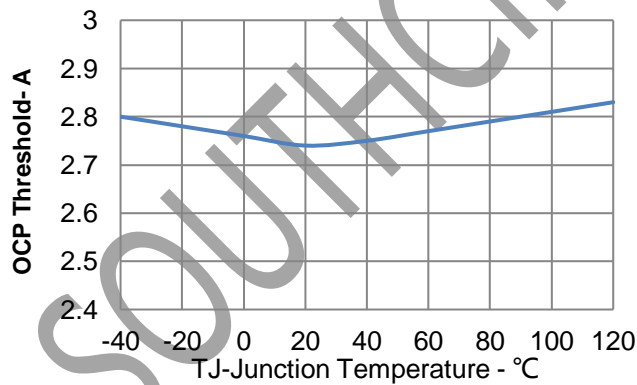
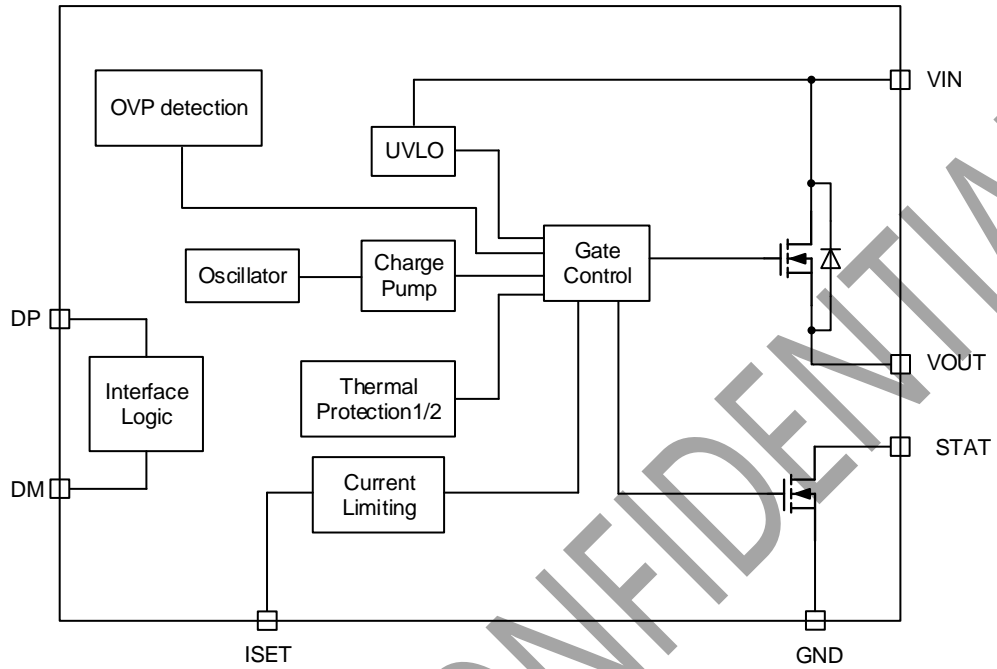

Figure 6 Over Current Protection (OCP) Threshold (R_{IST}=150K) VS. Temperature

8 Functional Block Diagram



9 Function Description

9.1 Under Voltage Lock Out Protection

The SC7004 provides Under Voltage Lock Out (UVLO) protection. When the input voltage is below the UVLO threshold, the switch is turned off. Once VIN is above UVLO threshold, the IC is enabled and it turns on the power switch after a 6ms delay time. Built-in hysteresis for UVLO threshold is implemented to prevent unwanted shutdown due to the input voltage variation caused by load transient.

9.2 Enable and Disable

The SC7004 is enabled automatically once the input voltage is above the UVLO threshold. With VIN power on, these parts can't be disabled.

9.3 Internal soft-start

The SC7004 provides built-in soft-start function. After enabled, it turns on the switch slowly (in 1 ~ 2ms) to limit the inrush current and voltage surges.

9.4 Constant Current Mode

The SC7004 provides a constant current function which can be programmable through an external resistor at ISET pin. Once the device detects the current reaches the current limit value, it works in constant current mode: it controls the gate driver voltage of the power switch so to regulate the current of the switch at the set value. The current limit value can be calculated by below equation:

$$I_{CC_LIM} = \frac{V_{REF}}{R_{ISET}} \times k$$

where ICC_LIM is the target current limit, VREF = internal reference voltage, 1.2V typically, RISET = ISET resistor value, k = 338,000 typically. For example, if a 150k resistor is connected at the ISET pin, the ICC_LIM is 2.7A.

When the IC works in constant current mode, the output voltage will be pulled down by the load current. If the output voltage still keeps higher than 3.8V at this mode, the SC7004 keeps limiting the current at the set value until the overload condition is removed or the IC begins thermal shutdown cycling. If the IC detects the output voltage drops below 3.8V, it starts short circuit protection (SCP).

9.5 Short Circuit Protection

When the IC detects the output voltage drops below 3.8V,

the SC7004 enters into short circuit hiccup mode. The SC7004 stays in hiccup mode until the over load or short circuit fault is removed.

Through the power cycling in hiccup mode, the average output current under short circuit condition can be significantly reduced to relieve the thermal stress to the chip.

9.6 Thermal Shutdown Cycling

The SC7004 provides two independent thermal sensing blocks that monitor the junction temperature in constant current mode and load switch mode.

When the SC7004 works in constant current mode, the IC keeps the switch on if the output voltage stays above 3.8V. In the case, there is a large voltage drop across the power switch, leading to high thermal dissipation. Once the SC7004 detects the junction temperature rises above 140°C, it turns off the switch; after it detects the temperature falls below 115°C, it turns on the switch again with the soft-start process.

When the SC7004 works in load switch mode, the IC turn on the switch fully, the output voltage is almost equal to the input put voltage with dozens of millivolt drop which caused by the R_{DS(on)}. Once the SC7004 detects the junction temperature rises above 150°C, it turns off the switch; after it detects the temperature falls below 125°C, it turns on the switch again with the soft-start process.

9.7 Status Indicator

The SC7004 features status indication at STAT pin. STAT pin is an open drain output, so can be connected with a pull up resistor and LED diode to VIN. The STAT pin is pulled low by the IC when the output is active.

9.8 Charging Port Controller

The SC7004 integrates a USB type-A port dedicated charging port controller. It can detect the type of the attached phone, and automatically support below common charging protocols:

1. USB battery charging specification, revision 1.2 (BC1.2)
2. Chinese Telecommunication Industry Standard YD/T 1591-2009
3. The divider mode for Apple device (DP = 2.7V, DM = 2.7V)
4. The 1.2V/1.2V Mode for Samsung device

PACKAGE

TSOT23-8

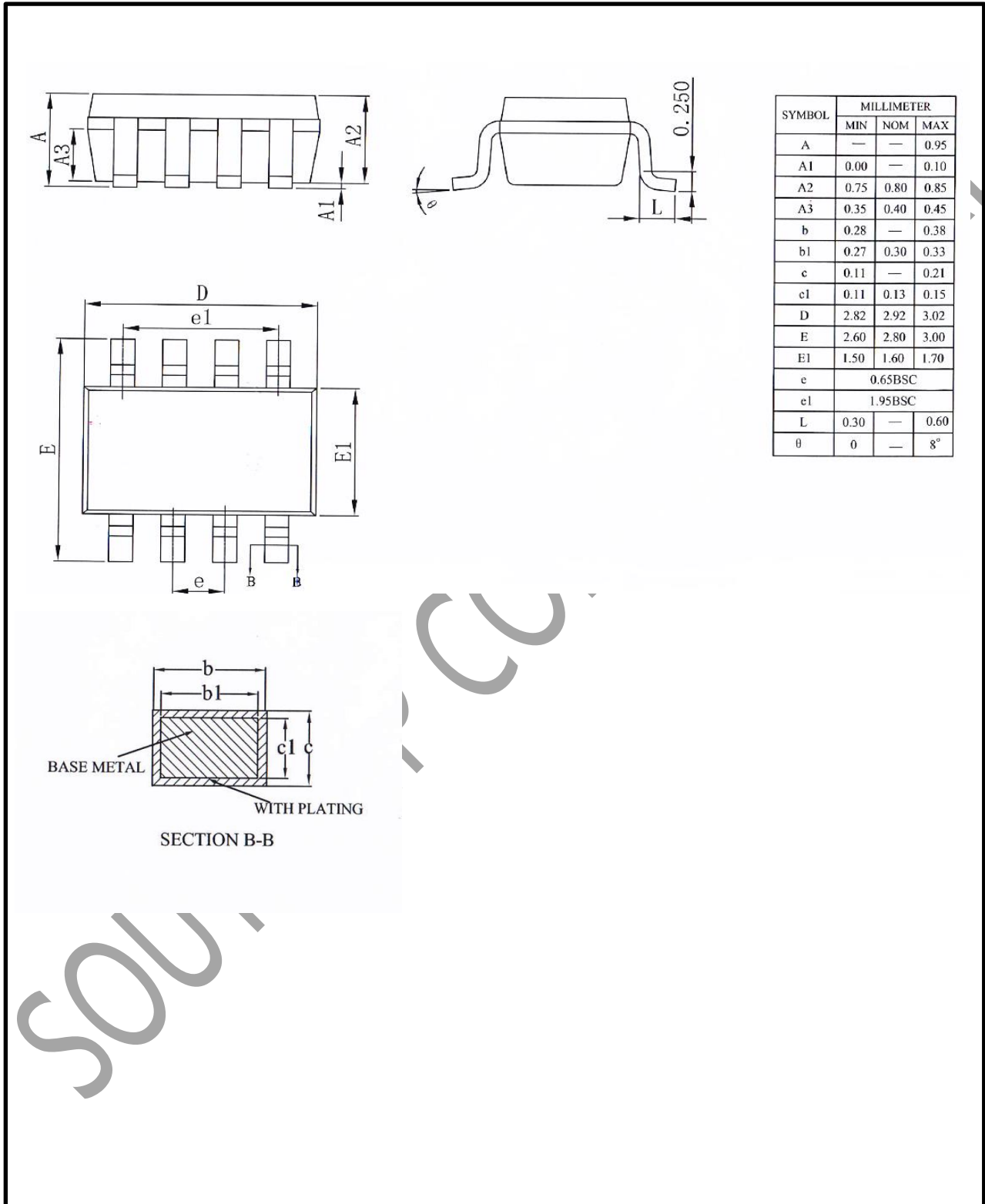

SYMBOL	MILLIMETER		
	MIN	NOM	MAX
A	—	—	0.95
A1	0.00	—	0.10
A2	0.75	0.80	0.85
A3	0.35	0.40	0.45
b	0.28	—	0.38
b1	0.27	0.30	0.33
c	0.11	—	0.21
c1	0.11	0.13	0.15
D	2.82	2.92	3.02
E	2.60	2.80	3.00
E1	1.50	1.60	1.70
e	0.65BSC		
e1	1.95BSC		
L	0.30	—	0.60
θ	0	—	8°