

General Description

The SE5120 series of fixed output ultra low dropout linear regulators are designed for portable battery powered applications, which require low power consumption and low dropout voltage. Each device contains a bandgap voltage reference, an error amplifier, a PMOS power transistor, and current limit and temperature limit protection circuits.

The SE5120 is designed to work with low cost electrolytic and ceramic capacitors and requires a minimum output capacitor of 10 μ F.

Features

- Typical 150mV Dropout Voltage at 500mA.
- Output Voltages: 0.8V to 3.9V (0.1V Step)
- Excellent Line and Load Regulation.
- High Accuracy Output Voltage of 2%.
- Ultra-Low Ground Current at 150 μ A (Typ.)
- Thermal and Over-Current Protection.
- Short Circuit Protection
- Standard SOT-223 and TO-252 Package.

Applications

- USB removable devices
- MPEG4 devices
- Wireless LAN's
- Hand-Held Instrumentation.
- Portable DVD players
- Digital camera

Typical Application

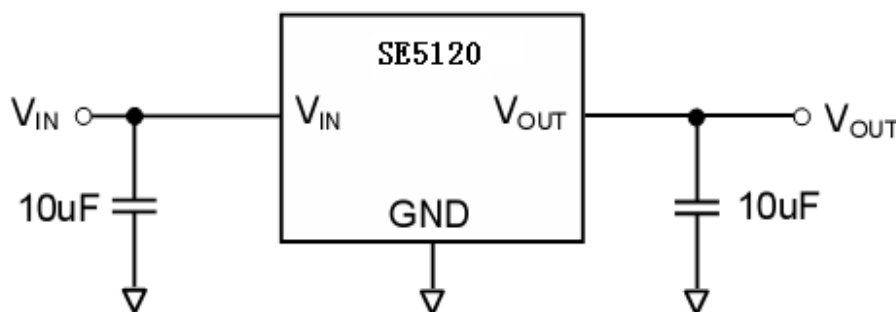



Pin Configuration

SOT-223 (Top View)

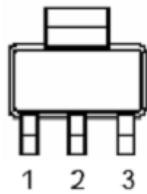

SE5120STXX 1:GND, 2:OUT, 3:IN

SOT -223 (Top View)

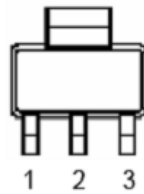

SE5120SGXX 1:IN, 2:GND, 3:OUT

TO-252 (Top View)

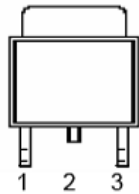

SE5120JTXX 1:GND, 2:OUT, 3:IN

TO-252 (Top View)

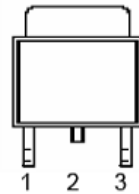

SE5120JGXX 1:IN, 2:GND, 3:OUT

Pin Description

Pin Name	Pin Function Description
GND	Ground
OUT	Output Voltage
IN	Input Voltage

Functional Block Diagram

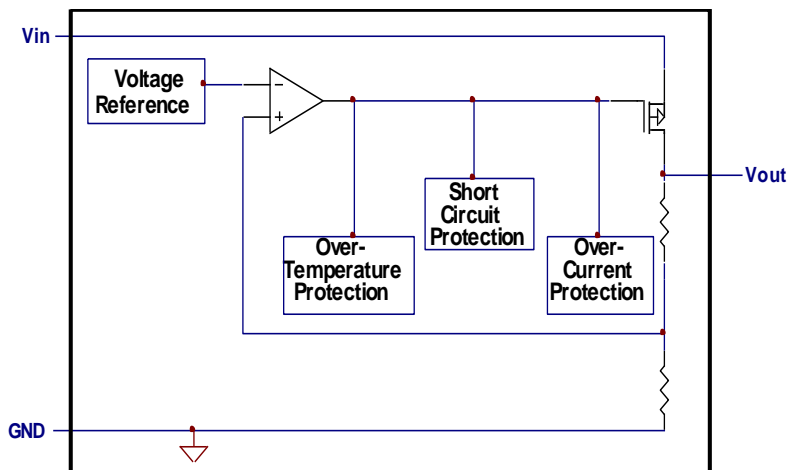



Ordering Information

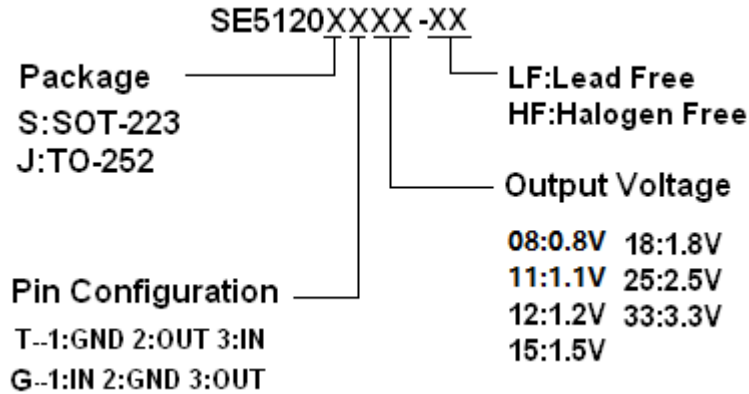

Device	Marking Information	Package	Remarks
SE5120STxx-LF	SE5120STXX-YYWW-LF	SOT-223	YYWW means Production batch XX denotes voltage options
SE5120SGxx-LF	SE5120SGXX-YYWW-LF		
SE5120JTxx-LF	SE5120JTXX-YYWW-LF	TO-252	
SE5120JGxx-LF	SE5120JGXX-YYWW-LF		
SE5120STxx-HF	SE5120STXX-YYWW-HF	SOT-223	YYWW means Production batch XX denotes voltage options
SE5120SGxx-HF	SE5120SGXX-YYWW-HF		
SE5120JTxx-HF	SE5120JTXX-YYWW-HF	TO-252	
SE5120JGxx-HF	SE5120JGXX-YYWW-HF		

Absolute Maximum Ratings

Parameter	Symbol	Value	Units
Input Voltage	V _{IN}	6	V
Output Voltage Range	V _{OUT}	-0.3 to V _{IN}	V
Power Dissipation	P _D	Internally Limited ⁽³⁾	
Output Short Circuit Duration		Infinite	
Thermal Resistance, Junction-to-Ambient	Θ _{JA}	155(SOT-223)	°C/W
		90(TO-252)	
Lead Temperature (Soldering, 5 sec.)		260	°C
Junction Temperature Range	T _J	0 to +150	°C
Storage Temperature Range	T _S	-40 to +150	°C



Recommended Operating Conditions

Parameter	Symbol	Value	Units
Supply Input Voltage Range	V_{IN}	5	V
Junction Temperature Range	T_J	0 to +125	°C

Electrical Characteristics

($V_{IN} = 5V$; $C_{IN} = 10\mu F$; $C_{OUT} = 10\mu F$; $I_{OUT} = 10mA$; $T_J = 25^\circ C$; unless otherwise noted)

Symbol	Parameter	Test Conditions	Min	Typ	Max	Unit
V_{OUT}	Output Voltage Accuracy	SE5120XX12	1.176	1.2	1.224	V
		SE5120XX15	1.47	1.5	1.53	
		SE5120XX18	1.764	1.8	1.836	
		SE5120XX25	2.45	2.5	2.55	
		SE5120XX33	3.234	3.3	3.366	
$\Delta V_{OUT}/V_{OUT}$	Line Regulation	$V_{IN} = (V_{OUT} + 0.7)V$ to 5.5V	--	0.1	--	%/V
$\Delta V_{OUT}/V_{OUT}$	Load Regulation ⁽⁵⁾	$V_{IN} = (V_{OUT} + 0.7)V$ $I_{OUT} = 10mA$ to 1500mA	--	2	--	%
$\Delta V_{OUT}/\Delta T$	Output Voltage Temperature Coefficient	Note 4	--	0.1	--	mV/°C
$V_{IN} - V_{OUT}$	Dropout Voltage ⁽⁶⁾	$I_{OUT} = 150mA$	--	40	--	mV
		$I_{OUT} = 500mA$	--	150	--	
		$I_{OUT} = 1000mA$	--	300	--	
$T_{PROTECTION}$	Thermal Protection	Thermal Protection Temperature	--	150	--	°C
		Protection Hysterisys	--	30	--	
I_Q	Quiescent Current	$I_{OUT} = 0mA$	--	150	--	μA
I_{LIMIT}	Current Limit		--	2.5	--	A
I_{short}	Short Circuit Current	$V_{in}=V_{out}+1V$; $V_{out}< 0.4V$	--	0.55	--	A

Note 1: Exceeding the absolute maximum rating may damage the device.

Note 2: The device is not guaranteed to function outside its operating rating.

Note 3: The maximum allowable power dissipation at any T_A (ambient temperature) is calculated using: $P_{D(MAX)} = (T_{J(MAX)} - T_A)/\theta_{JA}$. Exceeding the maximum allowable power dissipation will result in excessive die temperature, and the regulator will go into thermal shutdown. See "Thermal Consideration" section for details

Note 4: Output voltage temperature coefficient is the worst case voltage change divided by the total temperature range.



Note 5: Regulation is measured at constant junction temperature using low duty cycle pulse testing. Parts are tested for load regulation in the load range from 0.1mA to 1200mA. Changes in output voltage due to heating effects are covered by the thermal regulation specification.

Note 6: Dropout voltage is defined as the input to output differential at which the output voltage drops 2% below its nominal value measured at 1V differential.



Typical Performance Characteristics

Reference Voltage vs. Temperature

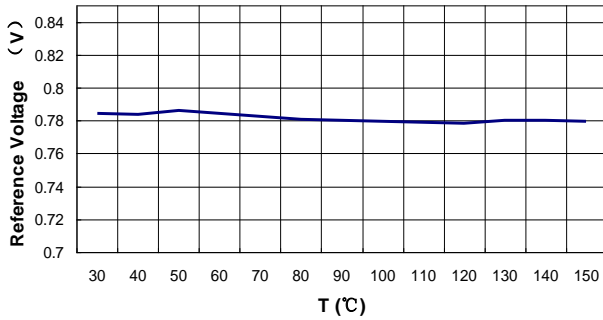

Output Voltage vs. Load Current

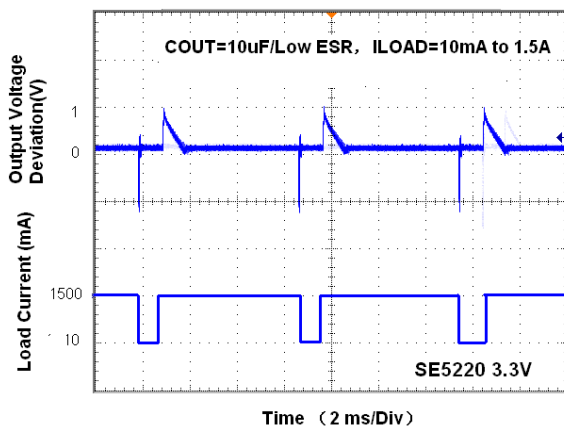
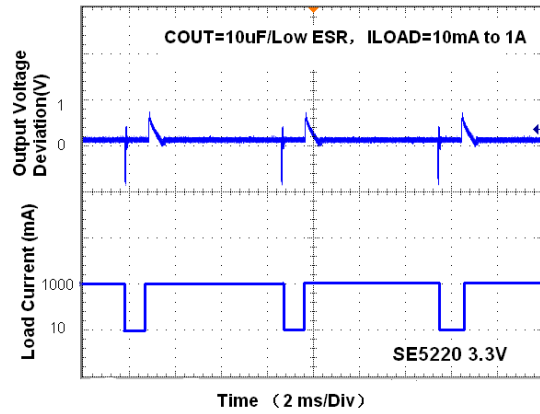
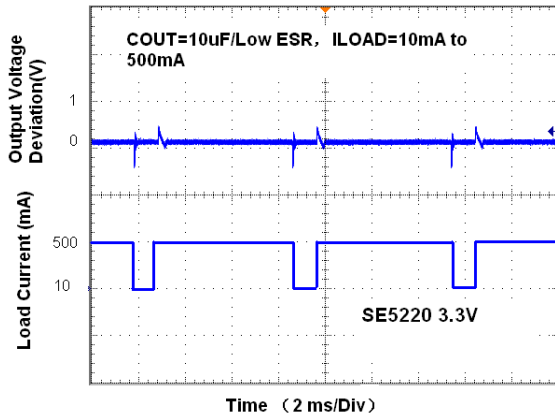
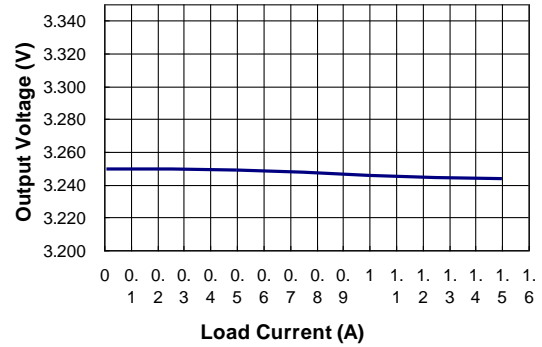

Output Voltage vs. Input Voltage

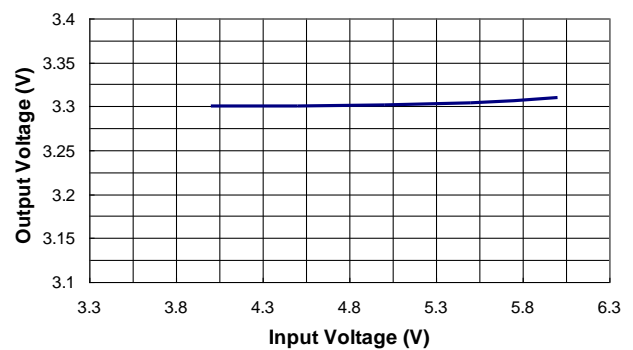



Applications Information

Application Hints

Like any low dropout regulator, SE5120 requires external capacitors to ensure stability. The external capacitors must be carefully selected to ensure performance.

Input Capacitor

An input capacitor of at least 10 μ F is required. Ceramic or Tantalum can be used. The value can be increased without upper limit.

Output Capacitor

An output capacitor is required for stability. It must be placed no more than 1 cm away from the V_{OUT} pin, and connected directly between V_{OUT} and GND pins. The minimum value is 10 μ F but may be increased without limit.

Thermal Considerations

It is important that the thermal limit of the package is not exceeded. The SE5120 has built-in thermal protection. When the thermal limit is exceeded, the IC will enter protection, and V_{OUT} will be pulled to ground. The power dissipation for a given application can be calculated as following:

The power dissipation (P_D) is

$$P_D = I_{OUT} * [V_{IN} - V_{OUT}]$$

The thermal limit of the package is then limited to $P_{D(MAX)} = [T_J - T_A] / \Theta_{JA}$ where T_J is the junction temperature, T_A is the ambient temperature, and Θ_{JA} is around 155°C/W (SOT-223) for SE5120. SE5120 is designed to enter thermal protection at 170°C. For example, if T_A is 25°C then the maximum P_D is limited to about 0.94W. In other words, if I_{OUT(MAX)} = 1200mA, then [V_{IN} - V_{OUT}] cannot exceed 780mV.



Outline Drawing For SOT-223

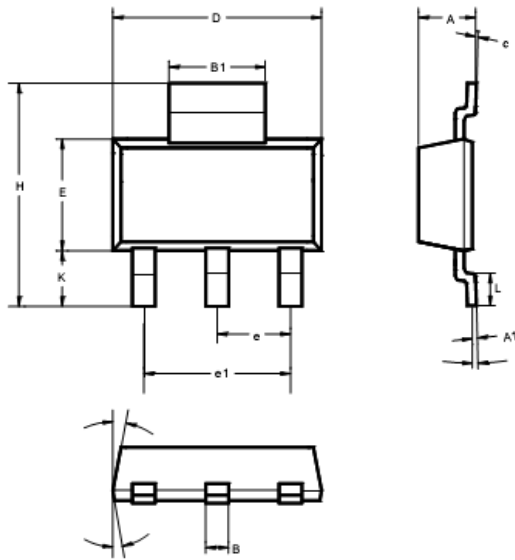

	MILLIMETERS		
	MIN	TYP	MAX
A	1.50	1.65	1.80
A1	0.02	0.05	0.08
B	0.60	0.70	0.80
B1	2.90	-	3.15
c	0.28	0.30	0.32
D	6.30	6.50	6.70
E	3.30	3.50	3.70
e	2.3 BSC		
e1	4.6 BSC		
H	6.70	7.00	7.30
L	0.91	1.00	1.10
K	1.50	1.75	2.00
α	0°	5°	10°
β		3°	

Outline Drawing For TO-252

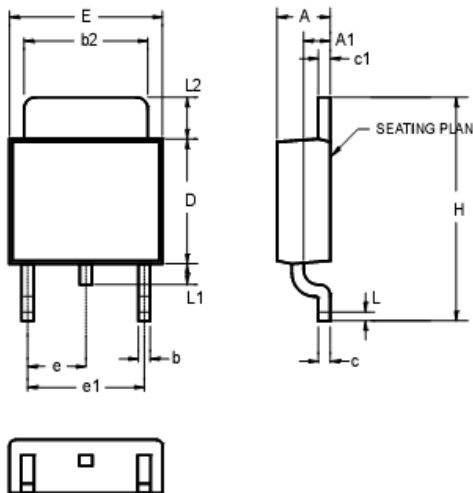

	INCHES			MILLIMETERS		
	MIN	TYP	MAX	MIN	TYP	MAX
A	0.086	-	0.094	2.18	-	2.39
A1	0.040	-	0.050	1.02	-	1.27
b	-	0.024	-	-	0.61	-
b2	0.205	-	0.215	5.21	-	5.46
c	0.018	-	0.023	0.46	-	0.58
c1	0.018	-	0.023	0.46	-	0.58
D	0.210	-	0.220	5.33	-	5.59
E	0.250	-	0.265	6.35	-	6.73
e	0.090 BSC			2.29 BSC		
e1	0.180 BSC			4.58 BSC		
H	0.370	-	0.410	9.40	-	10.41
L	0.020	-	-	0.51	-	-
L1	0.025	-	0.040	0.64	-	1.02
L2	0.060	-	0.080	1.52	-	2.03



联系方式:

北京思旺电子有限公司-中国总部

地址: 中国北京市海淀区信息路 22 号上地科技综合楼 B 座二层

邮编: 100085

电话:010-82895700/1/5

传真:010-82895706

Seaward Electronics Corporation – 台湾办事处

2F, #181, Sec. 3, Minquan East Rd,

Taipei, Taiwan R.O.C

电话: 886-2-2712-0307

传真: 886-2-2712-0191

Seaward Electronics Incorporated – 北美办事处

1512 Centre Pointe Dr.

Milpitas, CA95035, USA

电话: 1-408-821-6600