

REVISIONS					
REV	ECO	DESCRIPTION	DATE	BY	APPR
B1	-	RELEASED DRAWING	Nov-23-2014	Ben	Tommy

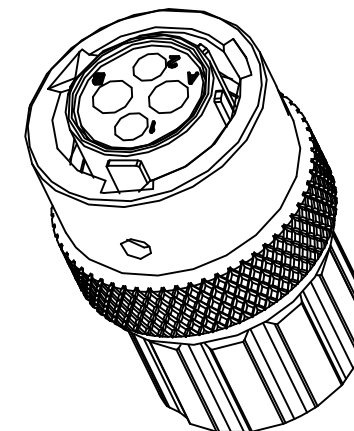
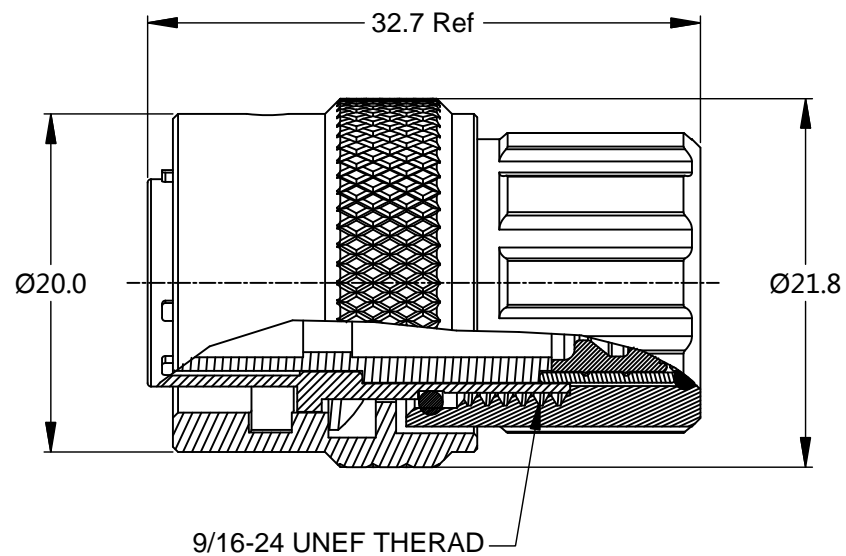
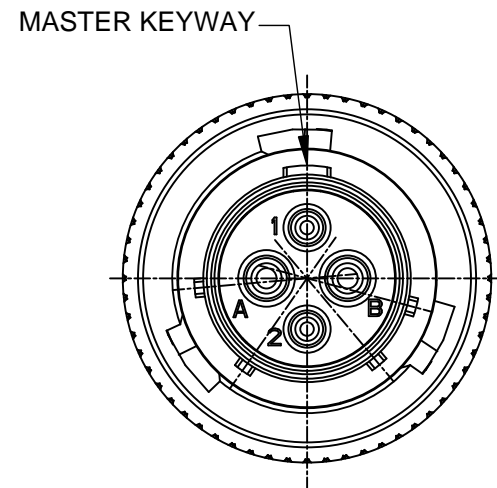

NOTES : (UNLESS OTHERWISE SPECIFIED)

- MATERIAL :
SHELL : ZINC ALLOY , NICKEL PLATED.
INSERT : THERMOPLASTIC , UL94 V-0.
END CAP : THERMOPLASTIC , UL94 V-0.
COUPLING NUT : AL ALLOY , NICKEL PLATED.
WAVE WASHER : STAINLESS STEEL.
O-RING : NBR/SILICONE RUBBER.
WIRE SEAL : SILICONE RUBBER.
PLASTIC BUSHING : THERMOPLASTIC , UL94 V-0.
- SPECIFICATIONS :
2.1 RATED CURRENT : 13A (MAX) .
2.2 RATED VOLTAGE : 300V (AC/DC) .
2.3 OPERATING TEMPERATURE : SEE CHART.
2.4 DIELECTRIC WITHSTANDING VOLTAGE : LESS THAN 2 MILLIAMPS CURRENT LEAKAGE@2000 VOLTS AC.
2.5 INSULATION RESISTANCE : 5000 MEGOHMS MIN.
2.6 IP--CLASS : IP67.
2.7 MATING CYCLES DURABILITY : 500 CYCLES(MIN).
2.8 ROHS COMPLIANT.
- SUITABLE CONTACTS : 16# CONTACTS.
- ALL DIMENSIONS ARE FOR REFERENCE USE ONLY.
- CONTACT SIZE AND REAR SEAL WIRE RANGE :

CONTACT SIZE	MIN. INSUL O.D.	MAX. INSUL O.D.	WIRE RANGE
16#	Ø2.0mm	Ø3.2mm	14 - 24AWG

KEY POS	PART NUMBER	
	-40°C ~ 105°C	-40°C ~ 125°C
N	RT06104SNHEC	RT06104SNHEC03
W	RT06104SWHEC	RT06104SWHEC03
X	RT06104SXHEC	RT06104SXHEC03
Y	RT06104SYHEC	RT06104SYHEC03
Z	RT06104SZHEC	RT06104SZHEC03

SEE PART NUMBER		CHART		DESCRIPTION		ITEM
QUANTITY	PART NUMBER	MATERIALS LIST				
UNLESS OTHERWISE SPECIFIED		SIGNATURES		DATE		<h1>Amphenol</h1> <p>Sine Systems - www.amphenol-sine.com 44724 Morley Drive Clinton Township, MI 48036</p> <p>ECO-MATE, PLUG, SIZE 10,4POS, SOCKET, END CAP.</p>
1) All dimensions are in metric(mm). 2) Tolerances are as follows: 1 PL DEC ±0.30 2 PL DEC ±0.15 3 PL DEC ±0.08		DRAWN: Ben		Nov-23-2014		
Fractions ±1/64 Angles ±1°		CHECKED:				
3) Note reference =		ENGINEER:				
MATERIAL SPECIFICATIONS:		APPROVAL:		CUSTOMER:		<p>THIS DRAWING IS SUPPLIED FOR INFORMATION ONLY. DESIGN FEATURES, SPECIFICATIONS AND PERFORMANCE DATA SHOWN HEREON ARE THE PROPERTY OF THE AMPHENOL CORPORATION. NO RIGHTS OF REPRODUCTION ARE IMPLIED. ALL DIMENSIONS ARE SUBJECT TO NORMAL MANUFACTURING VARIATIONS.</p>
PROCESS SPECIFICATIONS:		CUSTOMER:		SIZE TYPE DWG NO. REVISION		
NEXT ASSY:		CUSTOMER:		B C- RT06104S*HEC* B1		
		SCALE: NONE		SHEET 1 OF 1		

TITLE: ECO-MATE, PLUG, SIZE 10,4POS, SOCKET, END CAP. DWG NO.: RT06104S*HEC* REV: B1 SH: 1 OF: 1