

»Features

- 70Watts peak pulse power (tp = 8/20μs)
- Bidirectional configurations
- Solid-state silicon-avalanche technology
- Low clamping voltage
- Low leakage current
- Low capacitance (Cj=0.28pF typ. I/O to I/O)
- IEC 61000-4-2 ±15kV contact ±15kV air
- IEC 61000-4-4 (EFT) 40A (5/50ns)
- IEC 61000-4-5 (Lightning) 3.5A(8/20μs)

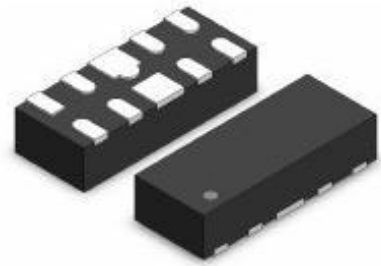

»Applications

- USB3.0, USB2.0,Ethernet
- HDMI 2.0, Displayport 1.3,eSATA
- Unified Display interface
- Digital Visual Interface
- High speed serial interface

»Mechanical Data

- Tiny DFN10L(2.5mmx1.0mm) package
- Molding compound flammability rating: UL 94V-0
- Packaging: Tape and Reel
- RoHS/WEEE Compliant

»Schematic & PIN Configuration

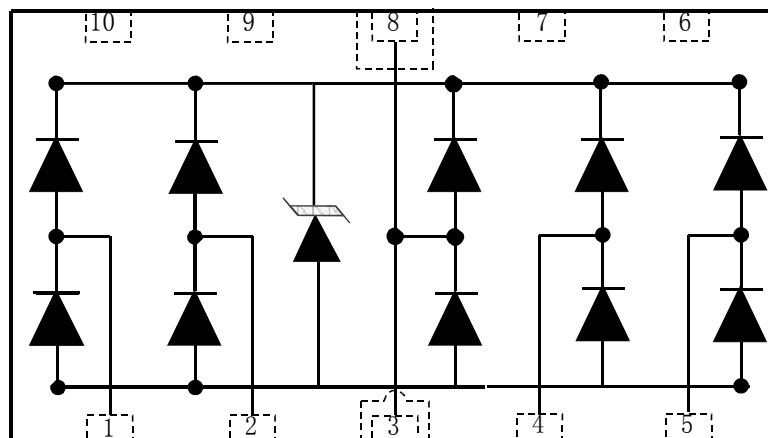

»Absolute Maximum Rating

Rating	Symbol	Value	Units
Peak Pulse Power ($t_p=8/20\mu s$)	P_{PP}	70	Watts
Peak Pulse Current ($t_p=8/20\mu s$) (note1)	I_{PP}	3.5	A
ESD per IEC 61000-4-2 (Air) ESD per IEC 61000-4-2 (Contact)	V_{ESD}	15 15	kV
Lead Soldering Temperature	T_L	260(10seconds)	°C
Junction Temperature	T_J	-55 to + 125	°C
Storage Temperature	T_{stg}	-55 to + 125	°C

»Electrical Characteristics

Parameter	Symbol	Conditions	Min	Typical	Max	Units
Reverse Stand-Off Voltage	V_{RWM}				5.0	V
Reverse Breakdown Voltage	V_{BR}	$I_T=1mA$	6.0	7.2	9.5	V
Reverse Leakage Current	I_R	$V_{RWM}=5V, T=25^\circ C$		0.02	0.5	μA
Peak Pulse Current	I_{PP}	$t_p=8/20\mu s$			3.5	A
Clamping Voltage	V_C	$I_{PP}=3.5A, t=8/20\mu s$		12	15	V
Clamping Voltage	V_{CL}	$I_{PP}=16A; t_p=TLP$			20	V
Junction Capacitance	C_j	$V_R=0V, f=1MHz$ I/O to I/O		0.20	0.3	pF
		$V_R=0V, f=1MHz$ I/O to GND		0.25	0.32	

»Electrical Parameters (TA = 25°C unless otherwise noted)

	Parameter
I_{PP}	Maximum Reverse Peak Pulse Current
V_C	Clamping Voltage @ I_{PP}
V_{RWM}	Working Peak Reverse Voltage
I_R	Maximum Reverse Leakage Current @ V_{RWM}
V_{BR}	Breakdown Voltage @ I_T
I_T	Test Current

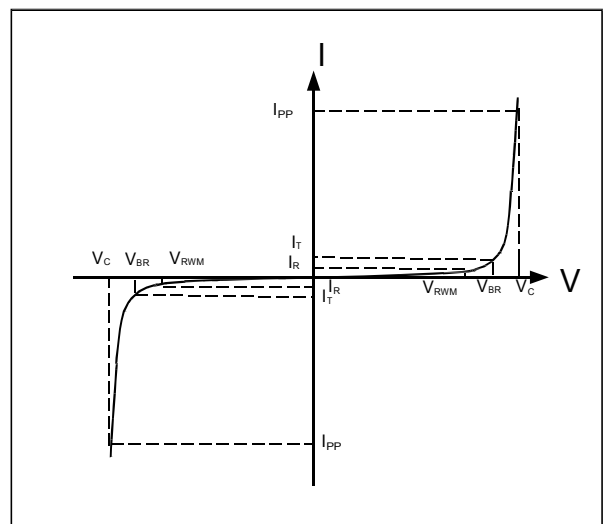

Note: $8/20\mu s$ pulse waveform.

»Typical Characteristic Curves

Fig.1 Peak Pulse Power Rating Curve

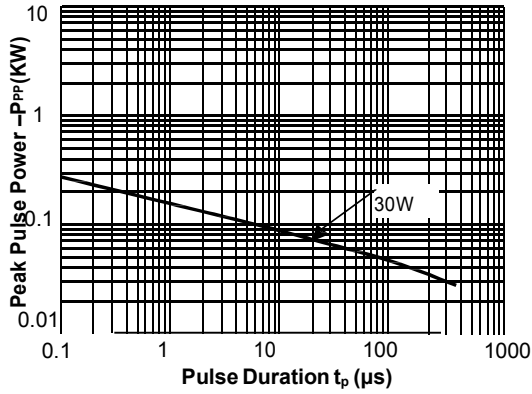

Fig.2 Pulse Derating Curve

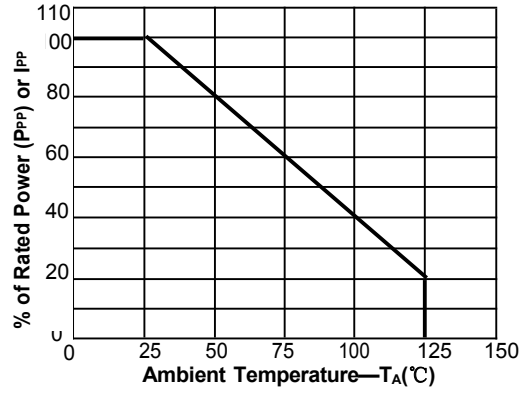

Fig.3 Pulse Waveform-8/20μs

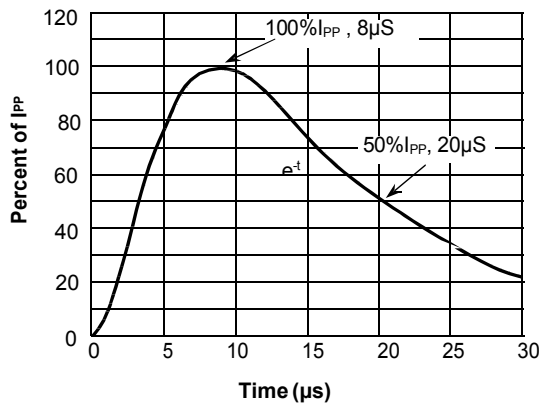

Fig.4 Pulse Waveform-ESD(IEC61000-4-2)

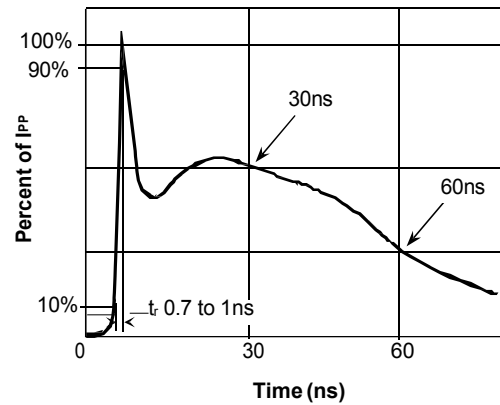

Fig.5 Eye Diagram - HDMI mask at 3.4Gbps per channel

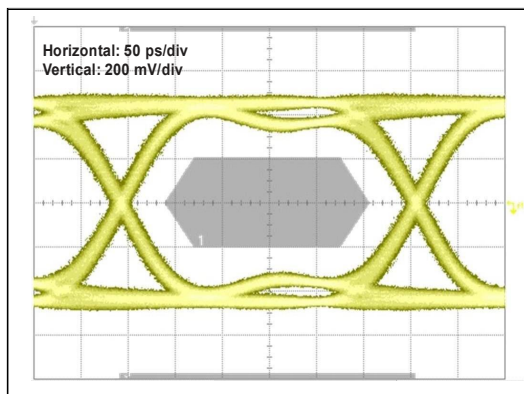
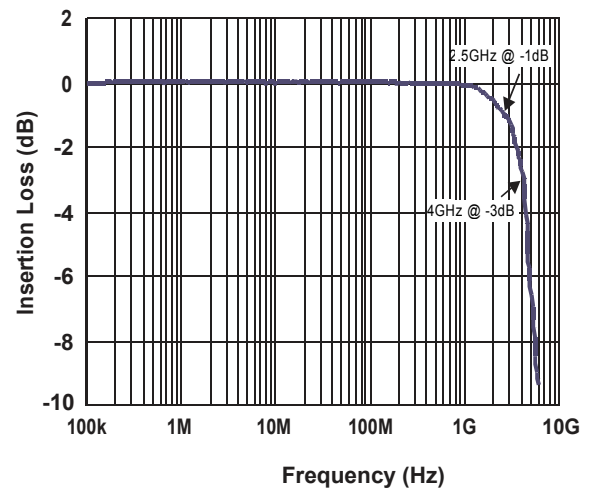
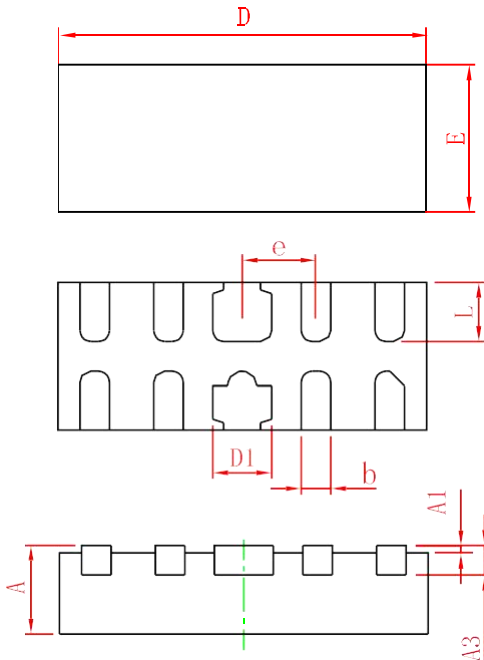

Fig.6 Insertion Loss S21 - I/O to GND



»Outline Drawing – DFN10L(2.5mmx1.0mm)



Symbol	Dimensions in millimeters		
	Min	Nom	Max
A	0.45	0.50	0.55
A1	-	0.02	0.05
A3	0.10	0.15	0.20
D	2.45	2.50	2.55
E	0.95	1.00	1.05
D1	0.35	0.40	0.45
b	0.15	0.20	0.25
e	0.50BSC		
L	0.35	0.40	0.45

»Marking

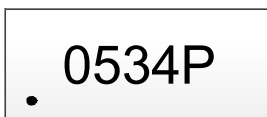

»Ordering information

Order code	Package	Base qty	Delivery mode
BDFN10C054R	DFN10L(2.5mmx1.0mm)	3k	Tape and reel