



REFERENCE SPECIFICATION

Customer: _____

Item:	Crystal Unit
Type:	NX2520SG
Nominal Frequency:	26 MHz
Customer's Spec. No.:	---
NDK Spec. No.:	EXS00A-CS08274

Receipt

Charge:

Sales	NDK-SH Cao Lei	Tel : 86-21-6278-5115 Mail: caolei@sh.ndk.com
Engineer	Engineering Dept. 1 Y. Takaki	Tel : (81)-4-2900-6653 Mail: takaki@ndk.com

Revision Record

Rev.	Rev. Date	Items	Contents	Approved	Checked	Drawn
---	05. Sep. 2014	Issue	---	I. Miyahara	T. Asamizu	Y. Takaki
A	07. Apr. 2016	4.6Load capacitance	7pF => 9pF	I. Miyahara	--	K.Tsukumo

1. Customer Specifications Number : ---
2. NDK Specification Number : EXS00A-CS08274
3. Type : NX2520SG

4. Electrical Characteristics

	Parameters	SYM.	Electrical Spec.				Notes
			Min	TYP	MAX	Units	
1	Nominal frequency	f_{nom}	26			MHz	-
2	Overtone order	-	Fundamental			-	AT-CUT
3	Frequency tolerance	-	-10	-	+10	ppm	at +25°C
4	Frequency versus temperature characteristics	-	-10	-	+10	ppm	at -25~+85°C The reference temperature shall be +25°C
5	Equivalent resistance	-	-	-	30	Ω	IEC π-Network / Series
6	Load capacitance	C_L	-	9	-	pF	IEC π-Network
7	Level of drive	DL	-	100	100	μW	-
8	Temperature coefficient						
8.1	1 st order curve fitting parameter	C1	-0.35	-	-0.13	ppm/°C	Fitting equation is defined by formula below and four kinds of temperature coefficient parameters, which are calculated from operating temperature under per 2 °C steps measurement data.
8.2	2 nd order curve fitting parameter	C2	-12	-	-5	$\times 10^{-4}$ ppm/°C ²	Same as 8.1
8.3	3 rd curve fitting parameter	C3	8.7	-	11	$\times 10^{-5}$ ppm/°C ³	Same as 8.1
9	Frequency perturbation	-	-0.5	-	0.5	ppm	*Measurement condition: Peak-to-peak deviation from the frequency versus temperature curve fit 3th order. Minimum of 1 frequency reading every 2°C over operating temperature range.
10	Pulling Sensitivity	PS	-10%	28	+10%	ppm/pF	This value is calculated by following formula. $PS = [ppm/pF] = \frac{C_m \times 1000}{2(C_p + C_L)^2}$ Unit: C_p (pF), C_m (fF) and C_L (pF)
11	Spurious mode resistance	-	500	-	-	Ω	within +/-1MHz
12	Aging						
12-1	Aging / 1 st year	-	-1	-	1	ppm	
12-2	Aging / 2 nd years	-	-1.5	-	1.5	ppm	
12-3	Aging / 5 years	-	-2.5	-	2.5	ppm	
12-4	Aging / 10 years	-	-5	-	5	ppm	
13	Drive level dependency (Drive level: 1nW to 100uW)						
13-1	DLD2	-	-	-	2.5	Ω	
13-2	DLDH2	-	-	-	1.5	Ω	
13-3	FDDL	-	-	-	2	ppm	
13-4	FDLH	-	-	-	0.7	ppm	
14	G sensitivity	-	-	-	2	$\times 10^{-9}$ /G	Gamma vector of all three axes from 30Hz to 1.5kHz

15	Insulation resistance	-	500	-	-	MΩ	Terminal to terminal insulation resistance also terminal to cover insulation resistance when DC100V ±15V is applied.
16	Full cycle temperature hysteresis	-	-0.5	-	0.5	ppm	Difference in freq. measurement at any temperature when undergoing a thermal cycle over the entire operation temperature range from -40 °C to 85 °C.
17	Small cycle temperature hysteresis	-	-0.05	-	0.05	ppm	Difference in freq. measurement at any temperature when undergoing a thermal cycle of a temperature range of 5 °C for each 1 °C test.
18	Frequency slope error over temperature	-	-0.05	-	0.05	ppm	at -10°C to +60 °C. *Measurement condition: Freq. slope error between measured S curve (fL) data and 3rd order curve fitting data over operation temperature under per 2 °C test.
19	Frequency slope error over temperature	-	0.1	-	0.1	ppm	at -30°C to +85 °C. *Measurement condition: Same as 18.
20	Operating temperature range	-	-30	-	+105	°C	-
21	Storage temperature range	-	-40	-	+85	°C	-
22	Air-tightness	-	-	-	1.1×10 ⁻⁹	Pa m ³ /s	Helium leak detector

5. Thermistor characteristics

- 5.1. Size : 0.6×0.3×0.3 (mm)
 5.2. Resistance value (at +25°C) : 100 (kΩ) ±1%
 5.3. B Constant (+25/+50°C) : 4250 (K) ±1%
 5.4. Rated power (at 25°C) : 100 (mW) Max.

6. Examination results document

Since a performance is guaranteed, an examination results document does not submit.

7. Application drawing

- 7.1. Dimension Drawing : EXD14B-00482
 7.2. Taping and Reel figure : EXK17B-00318
 7.3. Holder Marking : EXH11B-00319
 7.4. Reliability assurance Item : EXS30B-00808

8. Notice

Order items are manufactured according to specification. As to conditions, which are not indicated in this specification and unpredictable such as applied condition and oscillation margin, please check them beforehand.

9. Prohibited items

Be sure to use the product under the following conditions. Otherwise, the characteristics deterioration or destruction of the product may result.

- (1) Reflow soldering heat resistance
 Peak temperature: 265°C, 10 sec
 Heating: 230°C or higher, 40 sec
 Preheating: 150°C to 180°C, 120 sec
 Reflow passage times: twice
- (2) Manual soldering heat resistance
 Pressing a soldering iron of 400°C on the terminal electrode for four seconds (twice).

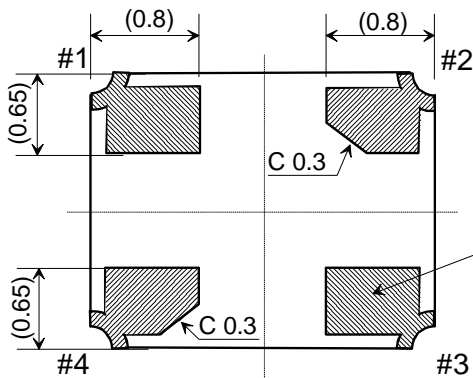
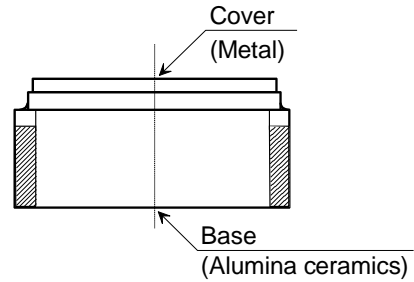
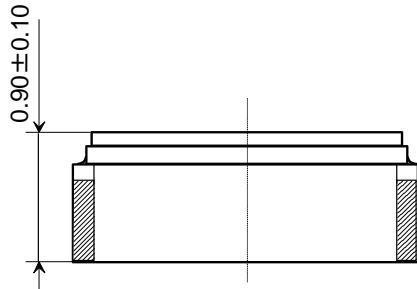
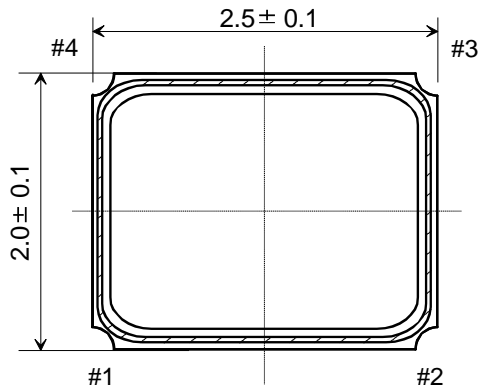

Terminal
Molybdenum metalize
(Au plating on Ni pre-plating)

Recommended land pattern

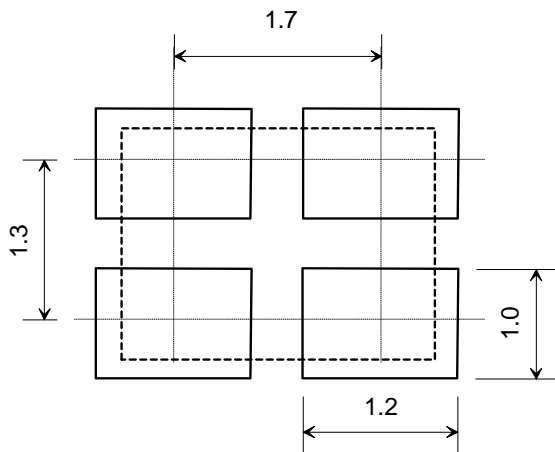

Terminal configuration
(TOP VIEW)

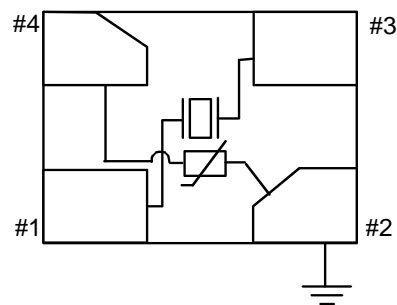

Terminal	Function
#1, #3	XTAL IN-OUT
#4	THERMISTOR IN
#2	THERMISTOR OUT
#2	GND (Connected with cover)

Date of Revise	Charge	Approved	Reason	
B 20. Apr. 2011	M. Wada	Y. Sakuma	Changed to terminal function table	
Date	Name	Third Angle Projection	Tolerance	
Drawn 17. Dec. 2010	T. Asamizu	Dimension: mm	---	
Designed 17. Dec. 2010	T. Asamizu	Title NX2520SG Dimension Drawing	Drawing No. EXD14B-00482	
Checked 17. Dec. 2010	I. Miyahara			Rev. B
Approved 17. Dec. 2010	K. Ueki			

NIHON DEMPA KOGYO CO., LTD.

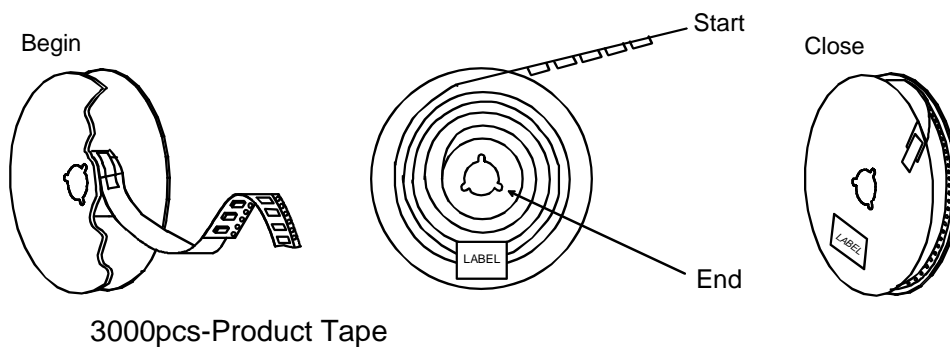
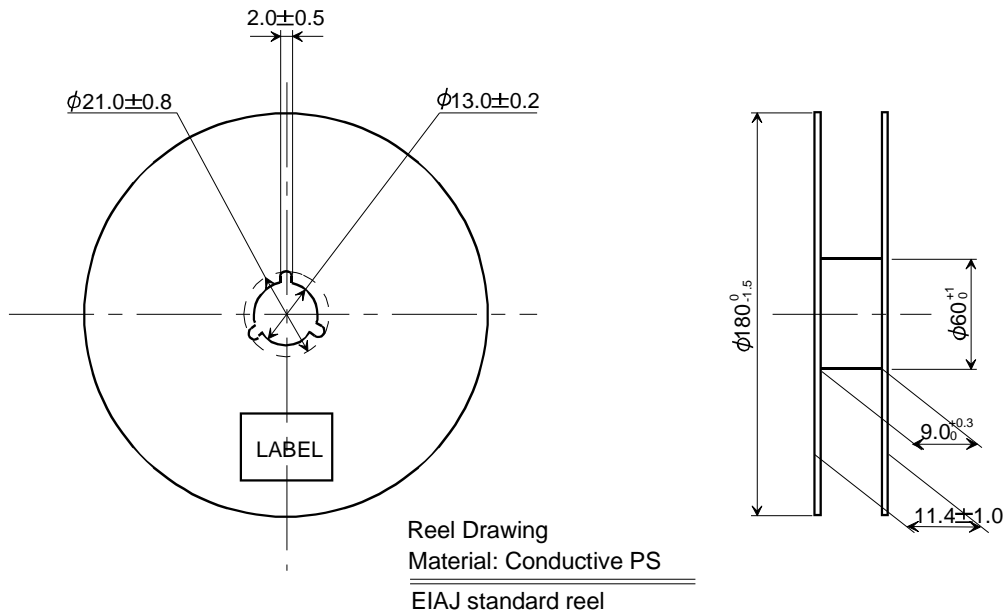
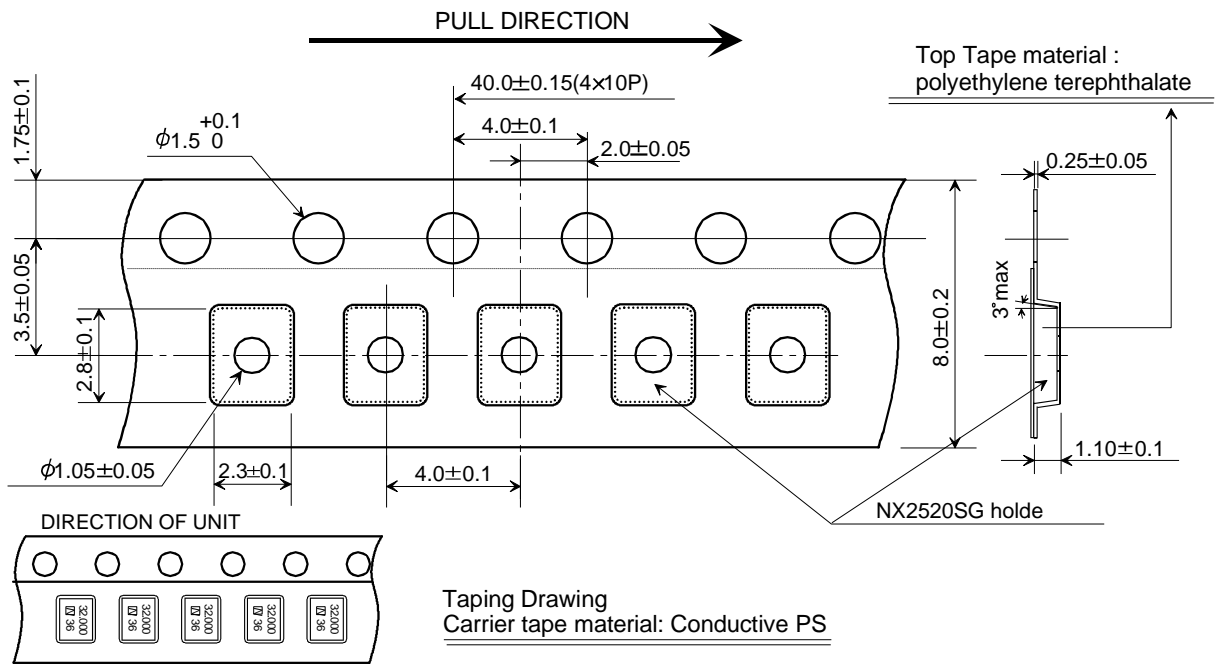

Date of Revise		Charge	Approved	Reason	
Drawn	06. Jan. 2011	T.Asamizu	Third Angle Projection		Scale
Designed	06. Jan. 2011	T.Asamizu	Dimension: mm		- / -
Checked	06. Jan. 2011	I.Miyahara	Title NX2520SG Taping and Reel Spec.		Drawing No. EXK17B-00318
Approved	06. Jan. 2011	K.Ueki			Rev. ---

NIHON DEMPA KOGYO CO., LTD.

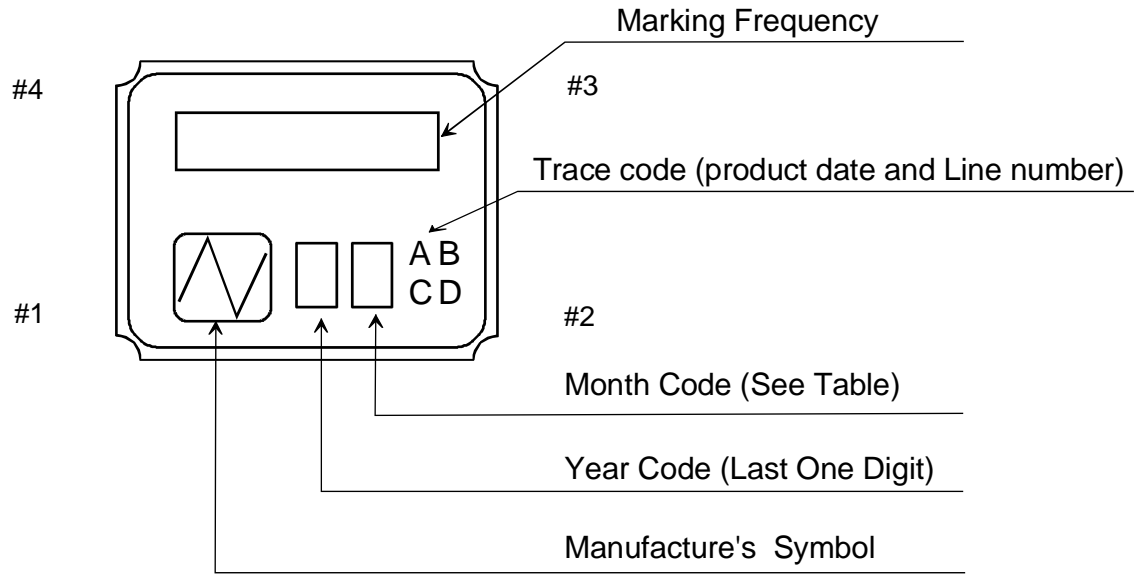

NOTE

1. Month Code Table

Month	1 Jan.	2 Feb.	3 Mar.	4 Apr.	5 May.	6 Jun.	7 Jul.	8 Aug.	9 Sep.	10 Oct.	11 Nov.	12 Dec.
Month Code	1	2	3	4	5	6	7	8	9	X	Y	Z

*Marking digits are not include a decimal point and dot mark.

	Date of Revise	Charge	Approved	Reason	
A	10. Jul. 2008	T.Asamizu	K.Kubota	Delete application period.	
	Date	Name	Third Angle Projection	Tolerance	Scale
Drawn	14. Feb. 2006	T.Asamizu	Dimension:mm		/
Designed	14. Feb. 2006	T.Asamizu	Title Crystal Holder Marking	Drawing No. EXH11B-00319	Rev.
Checked	14. Feb. 2006	I.Miyahara			A
Approved	14. Feb. 2006	K.Okamoto			

NIHON DEMPA KOGYO CO., LTD.

Reliability assurance item (1/1)

(page: 1/2)

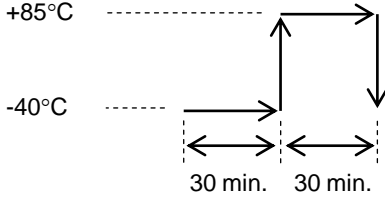
No.	Test Item	Test Methods	Spec. Code	
1	High temperature	Temperature: +85 °C Test time: 500 Hr.	A, C	
2	Cold resistance	Temperature: -40 °C Test time: 500 Hr.	A, C	
3	Humidity	at +85 °C with 80 to 85 % RH for 500 hours.	A, C	
4	Thermal shock	Temperature cycle as shown in (Fig.1) for 100 cycle.  <p style="text-align: center;">ONE CYCLE (Fig.1)</p>	A, C	
5	Vibration	Frequency Range	10 to 2000Hz	A, C
		Amplitude or Acceleration	1.52 mm or 20 G	
		1 cycle	20 minutes	
		Test time	Three mutually perpendicular axes each 12 times.	
6	Shock 1	Shock	3000 Gs 0.3 msec.	A, C
		Test time	Six mutually perpendicular axes each 1 times.	
7	Shock 2	Shock	Device are put on the weight of 200 g and dropped on concrete board.	A, C
		Height	1.5 m	
		Drop times	Six mutually perpendicular axes each 10 times.	
8	Solerability	Residual heat temperature	150 °C	B
		Residual heat time	60 to 120 sec	
		Peak temperature	240°C (more than 215 °C 10 to 30 sec)	
9	Reflow resistance	Temperature cycle as shown in (Fig2.) for 3 cycle.	A, C	

Specification code	Specification
A	$\Delta F/F \leq \pm 1.0$ ppm $\Delta Cl \leq \pm 15$ % or $\pm 2 \Omega$ greater value
B	The electrodes shall acquire a new solder coat over at least 90 % of immersed area.
C	Thermistor resistance: $\Delta R/R \leq 5\%$

Reliability assurance item (2/2)

Recommended reflow profile

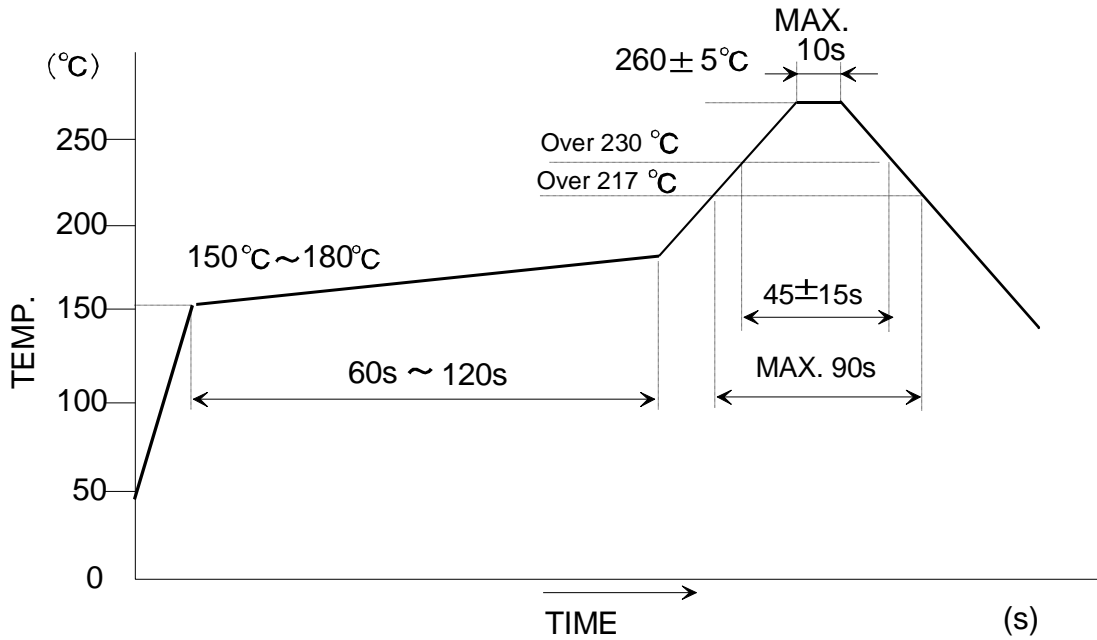

- A: 150 to 180 °C (90 ± 30 sec.)
- B: 230°C min. (45 ± 15 sec.)
- C: Peak temperature. 260°C ± 5 °C (10sec. max.)
- D: 217 °C Min. (90 sec. max.)