

SLVU2.8

Low Voltage EPD TVS Diode For ESD and Latch-Up Protection Revision:B

General Description

The Ultraslow Capacitance Transient Voltage Suppressors are designed to low voltage, integrated circuits from transients caused by electrostatic discharge (ESD), electrical fast transients (EFT), tertiary lightning and other induced voltages.

Applications

- Ethernet – 10/100/1000 Base T
- WAN/LAN Equipment
- Desktops, Servers, Notebooks & Handhelds
- Laser Diode Protection

Features

- 400 W Peak Pulse Power per Line (tp=8/20μs)
- One Device protects one Unidirectional Line.
- Low Capacitance.
- Low Leakage Current.
- Low Operating and Clamping Voltages.
- Transient Protection for High Speed Data Lines to

IEC61000-4-2(ESD) ±15kV(air), ±8kV(Contact)

IEC61000-4-4(EFT) 40A(5/50ns)

IEC61000-4-5(lightning) 24A(8/20us)

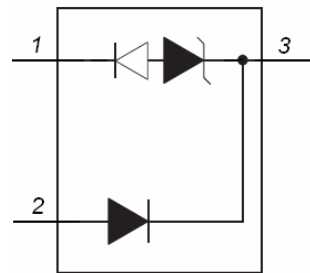
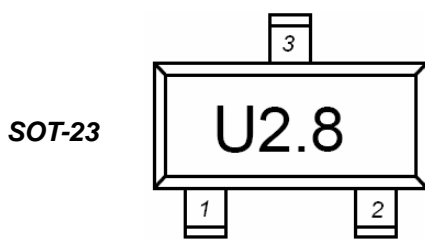

Absolute Maximum Ratings

Parameter	Symbol	Value	Units
Peak Pulse Power (tp = 8/20μs) - See Fig1.	P _{PK}	400	W
Peak Pulse Current (tp = 8/20μs)	I _{PP}	24	A
Storage Temperature Range	T _{STG}	-55 to 150	°C
Operating Junction Temperature Range	T _J	-55 to 150	°C

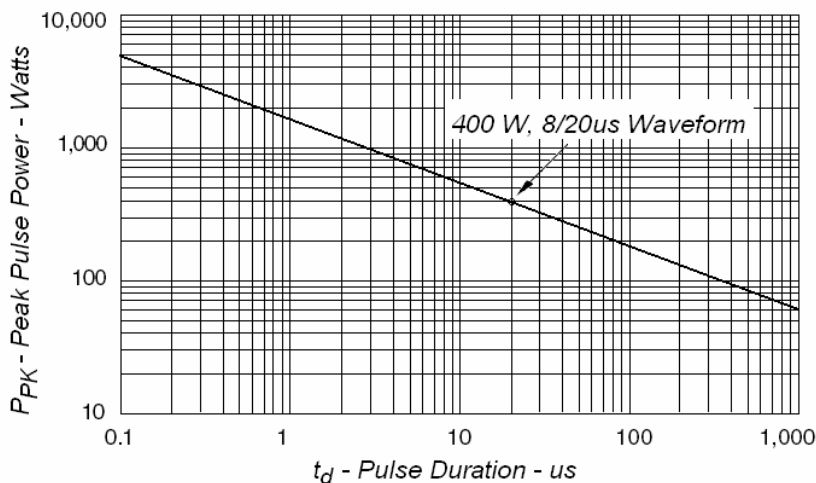

Fig1. Peak Pulse Power VS Pulse Time

Electrical Parameter

Symbol	Parameter
I_{PP}	Peak Pulse Current
V_C	Clamping Voltage @ I_{PP}
V_{RWM}	Reverse Stand-Off Voltage
I_R	Reverse Leakage Current @ V_{RWM}
V_{SB}	Snap-Back Voltage @ I_{SB}
I_{SB}	Snap-Back Current
V_{PT}	Punch-Through Voltage
I_{PT}	Punch-Through Current
V_{BRR}	Reverse Breakdown Voltage @ I_{BRR}
I_{BRR}	Reverse Breakdown Current

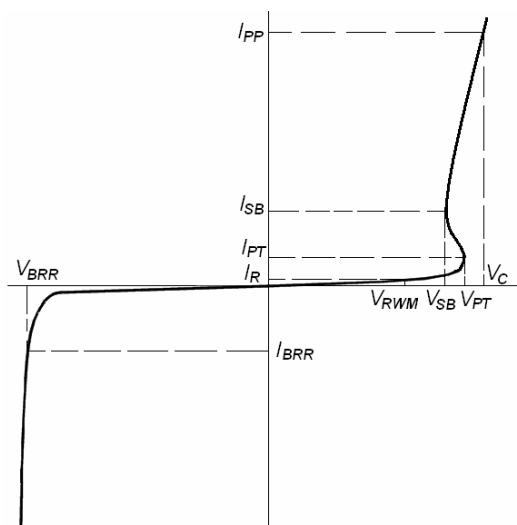

Fig 2. SLVU2.8 IV Characteristic Curve

Electrical Characteristics

Parameter	Symbol	Conditions	Minimum	Typical	Maximum	Units
Reverse Stand-Off Voltage	V_{RWM}	Pin 3 to 1 or Pin 2 to 1			2.8	V
Punch-Through Voltage	V_{PT}	$I_{PT} = 2\mu A$, Pin 3 to 1	3.0			V
Snap-Back Voltage	V_{SB}	$I_{SB} = 50mA$, Pin 3 to 1	2.8			V
Reverse Leakage Current	I_R	$V_{RWM} = 2.8V$, $T = 25^\circ C$ Pin 3 to 1 or Pin 2 to 1			1	μA
Clamping Voltage	V_C	$I_{PP} = 2A$, $t_p = 8/20\mu s$ Pin 3 to 1			3.9	V
Clamping Voltage	V_C	$I_{PP} = 5A$, $t_p = 8/20\mu s$ Pin 3 to 1			7	V
Clamping Voltage	V_C	$I_{PP} = 24A$, $t_p = 8/20\mu s$ Pin 3 to 1			12.5	V
Clamping Voltage	V_C	$I_{PP} = 5A$, $t_p = 8/20\mu s$ Pin 2 to 1			8.5	V
Clamping Voltage	V_C	$I_{PP} = 24A$, $t_p = 8/20\mu s$ Pin 2 to 1			15	V
Junction Capacitance	C_j	Pin 3 to 1 and 2 (Pin 1 and 2 tied together) $V_R = 0V$, $f = 1MHz$		70	100	pF
Junction Capacitance	C_j	Pin 2 to 1 (Pin 3 N.C.) $V_R = 0V$, $f = 1MHz$		3.5	5	pF

Steering Diode Characteristics

Parameter	Symbol	Conditions	Minimum	Typical	Maximum	Units
Reverse Breakdown Voltage	V_{BRR}	$I_T = 10\mu A$, Pin 3 to 2	40			V
Reverse Leakage Current	I_{BRR}	$V_{RWM} = 2.8V$, $T = 25^\circ C$ Pin 3 to 2			1	UA
Forward Voltage	V_F	$I_F = 1A$, Pin 2 to 3			2	V

Typical Characteristics

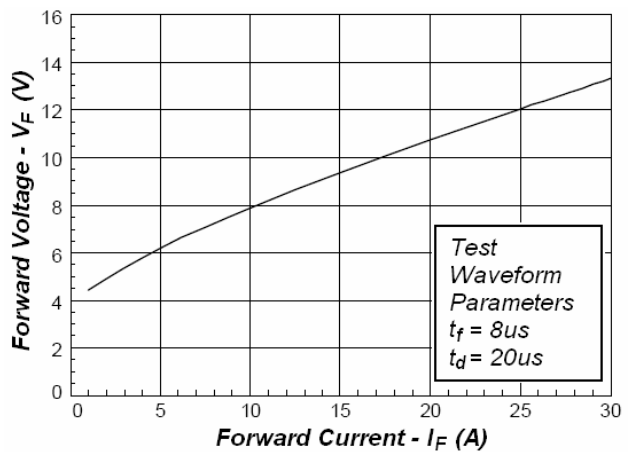
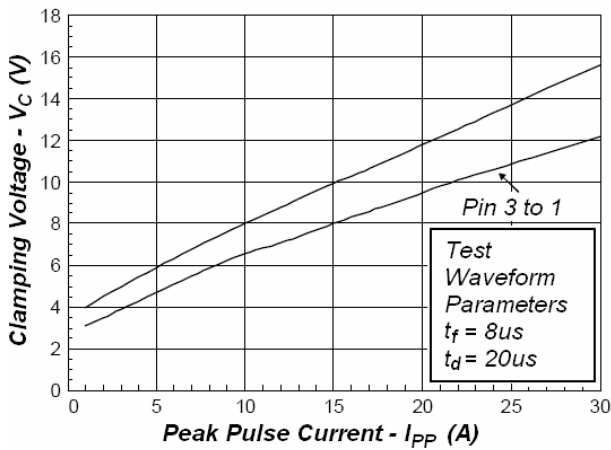
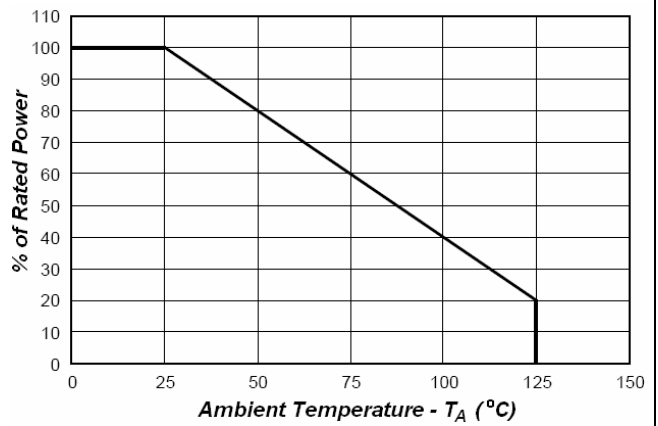
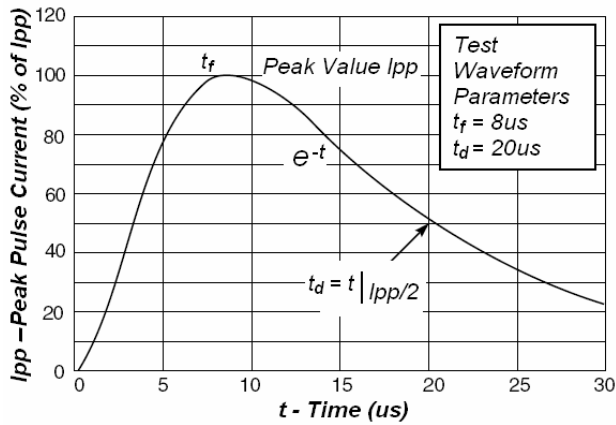

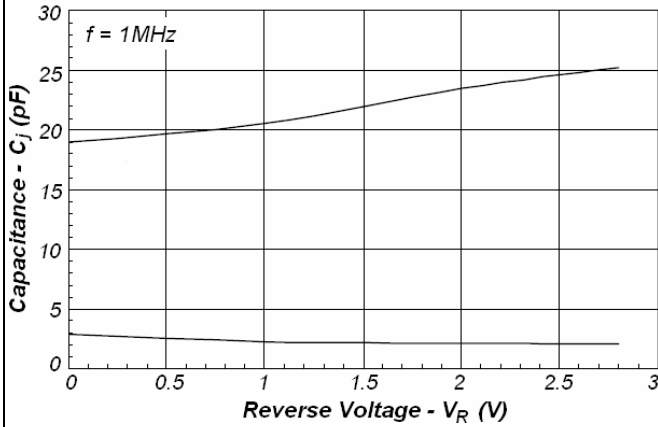

Fig7 Reverse Voltage vs. Capacitance



Fig8. Insertion Loss S21

Application Note

The SLVU2.8 is ideal for providing protection for electronic equipment that is susceptible to damage caused by Electrostatic Discharge (ESD), Electrical Fast Transients (EFT) and tertiary lightning effects. This product is offered in a unidirectional configuration and provides both commonmode and differential-mode protection.

Unidirectional Common-Mode Protection (Figure 9)

The SLVU2.8 provides one line of unidirectional protection in a common-mode configuration as depicted in figure 9.

Circuit connectivity is as follows:

- Line 1 is connected to Pin 3
- Pins 1 and 2 are connected to ground

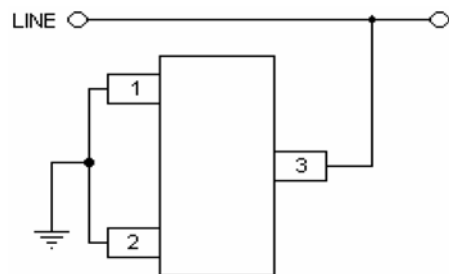

Fig9.

Bidirectional Common-Mode Protection (Figure 10)

Two SLVU2.8 devices provide one line of bidirectional protection in a common-mode configuration as depicted in figure 10.

Circuit connectivity is as follows:

- Line 1 is connected to Pin1 of Device 1 & Pin 2 of Device 2
- Pin 2 of Device 1 and Pin 1 of Device 2 are connected to ground
- Pin 3 of both devices is not connected

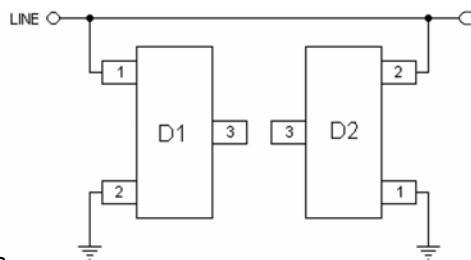

Fig10.

Bidirectional Differential-Mode Protection (Figure 11)

Two SLVU2.8 devices provide up to two lines of bidirectional protection in a differential mode configuration as depicted in figure 11.

Circuit connectivity is as follows:

- Line 1 is connected to Pin1 of Device 1 & Pin 2 of Device 2
- Line 2 is connected to Pin 2 of Device 1 & Pin 1 of Device 2

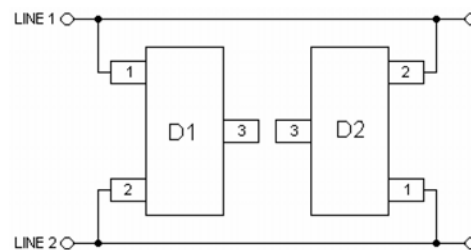

Fig11.

Circuit Board Layout Protection

Circuit board layout is critical for Electromagnetic Compatibility (EMC) protection. The following guidelines are recommended:

- The protection device should be placed near the input terminals or connectors, the device will divert the transient current immediately before it can be coupled into the nearby traces.
- The path length between the TVS device and the protected line should be minimized.
- All conductive loops including power and ground loops should be minimized.
- The transient current return path to ground should be kept as short as possible to reduce parasitic inductance.
- Ground planes should be used whenever possible. For multilayer PCBs, use ground vias.

Typical Applications

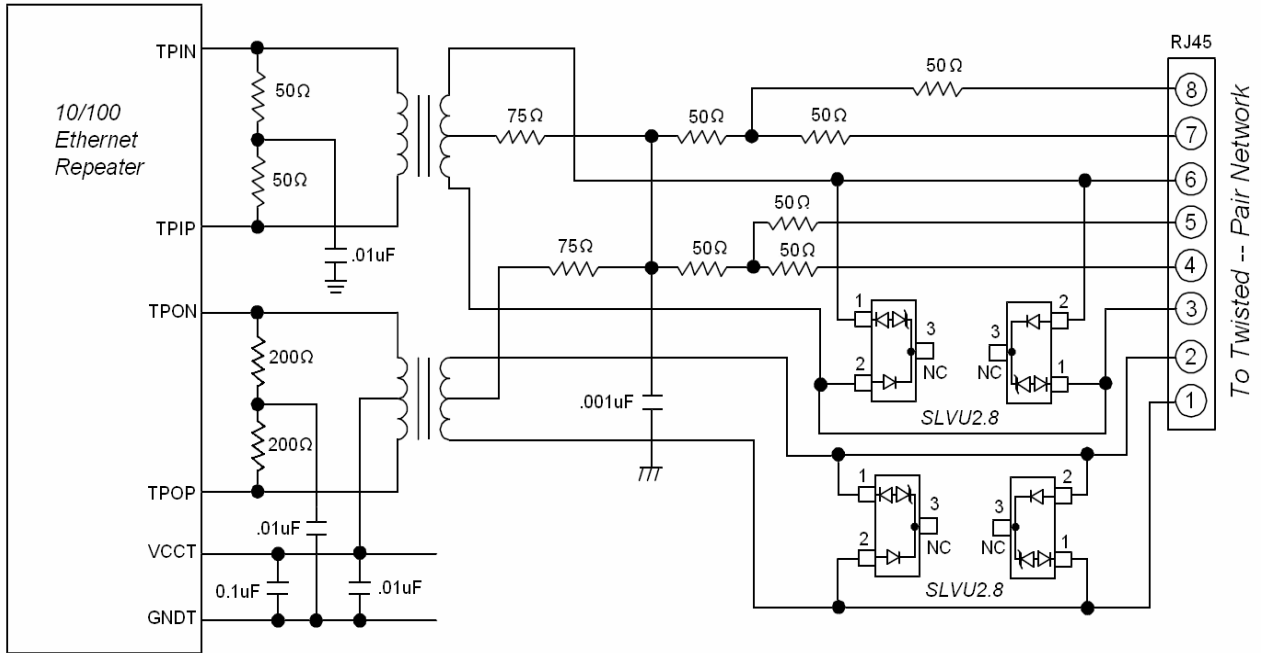

Fig12. 10/100 Ethernet Protection Circuit

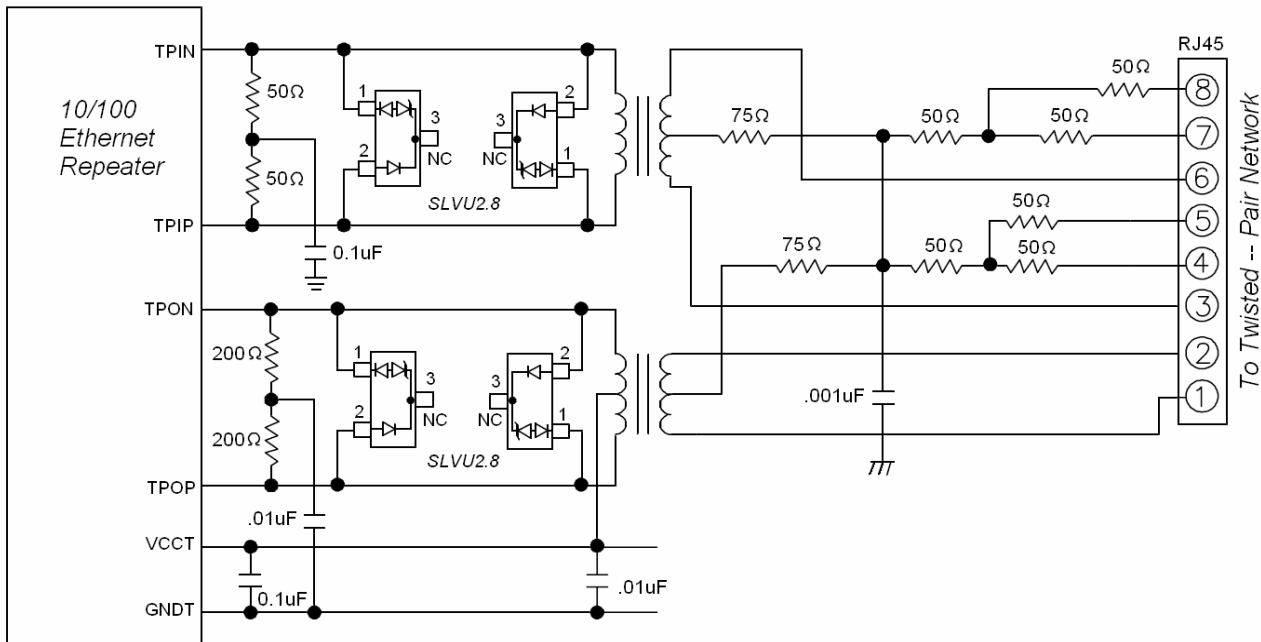
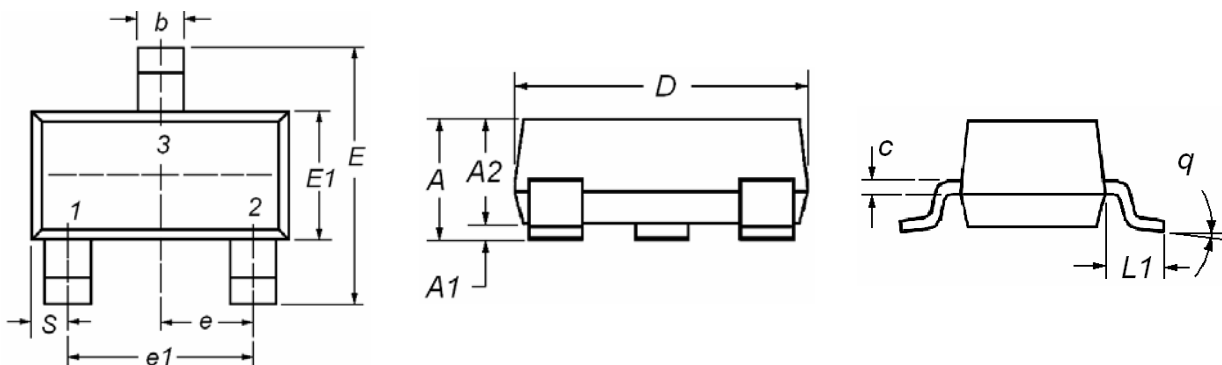

Fig13. 10/100 Ethernet "Enhanced" Lightning Protection Circuit

SOT-23 Mechanical Data

Dim	Millimeters		
	Min	TYP	Max
A	1.00		1.40
A1	0		0.10
A2	1.00		1.30
b	0.35		0.50
c	0.10		0.20
D	2.70	2.90	3.10
E	2.40		2.80
E1	1.40		1.60
e	0.85		1.15
e1		1.90	
L1	0.40	.	
q	0°		10°
S	0.45		0.55



The SINO-IC logo is a registered trademark of ShangHai Sino-IC Microelectronics Co., Ltd.

© 2005 SINO-IC – Printed in China – All rights reserved.

SHANGHAI SINO-IC MICROELECTRONICS CO., LTD

Add: Building 3, Room 3401-03, No.200 Zhangheng Road, ZhangJiang Hi-Tech Park, Pudong, Shanghai 201203, China

Phone: +86-21-33932402 33932403 33932405 33933508 33933608

Fax: +86-21-33932401

Email: webmaster@sino-ic.com

Website: <http://www.sino-ic.com>