

SEB0545 & SEB05100
SMD Schottky Barrier Diodes

Revision: A

General Description

This Schottky diode is for use in low voltage, high frequency rectifier of switching mode power supplier, DC/DC converters and polarity protection application.

- Low power loss, high efficiency
- Low Forward Voltage Drop
- High forward surge capacity

Features

- Case: SMA, molded epoxy body
- Terminal: Matte tin plated leads
- Polarity: See mark on body

Maximum Ratings ($T_A=25^{\circ}\text{C}$ unless otherwise noted)

Parameter	Symbol	SEB0545	SEB05100	Units
Maximum repetitive peak reverse voltage	V_{RRM}	45	100	V
Maximum RMS voltage	V_{RMS}	31	70	V
Maximum DC blocking voltage	V_{DC}	45	100	V
Maximum average forward rectifier current	$I_{F(AV)}$	5.0		A
Peak forward surge current 8.3ms single half sine-wave superimposed on rated load	I_{FSM}	80		A
Operating Junction Temperature Range	T_J, T_{STG}	-50 to 150		$^{\circ}\text{C}$

Electrical Characteristics ($T_A=25^{\circ}\text{C}$ unless otherwise noted)

Parameter	Condition	Symbol	SEB0545	SEB05100	Units
Maximum instantaneous forward voltage	$I_F=5\text{A}$	V_F	0.42	0.46	V
Maximum DC reverse current at blocking voltage	$T_C=25^{\circ}\text{C}$	I_R	0.5		mA
	$T_C=125^{\circ}\text{C}$		50		

Thermal Characteristic ($T_A=25^{\circ}\text{C}$ unless otherwise noted)

Parameter	Symbol	SEB0545~ SEB05100	Units
Typical Thermal resistance	$R_{\theta JA}^{(1)}$	75	$^{\circ}\text{C/W}$

1. P.C.C. Mounted with 0.2"× 0.2"(5.0×5.0mm) copper pads

Ratings and Characteristics Curves ($T_A=25^{\circ}\text{C}$ unless otherwise noted)

F1G.1-FORWARD CURRENT DERATING CURVE

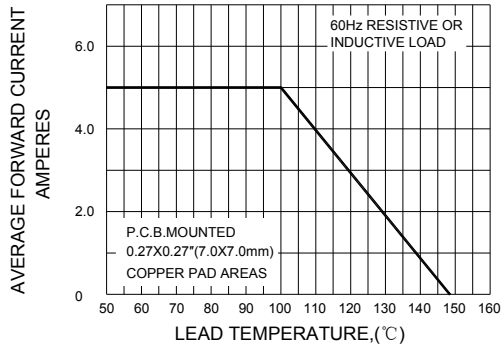

F1G.2-MAXIMUM NON-REPETITIVE PEAK FORWARD SURGE CURRENT

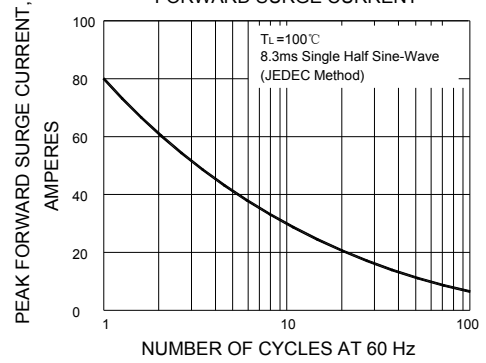

F1G.3-TYPICAL INSTANTANEOUS FORWARD CHARACTERISTICS

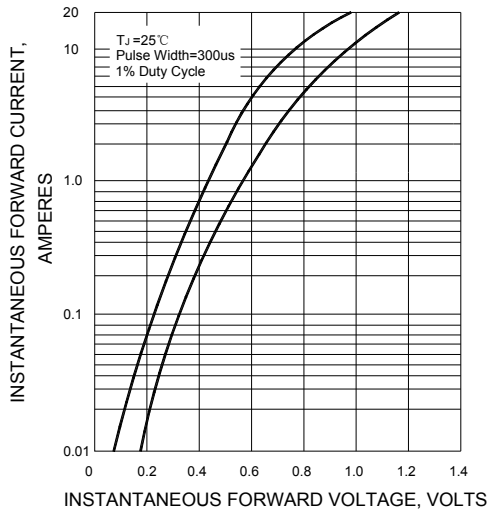

F1G.4-TYPICAL REVERSE CHARACTERISTICS

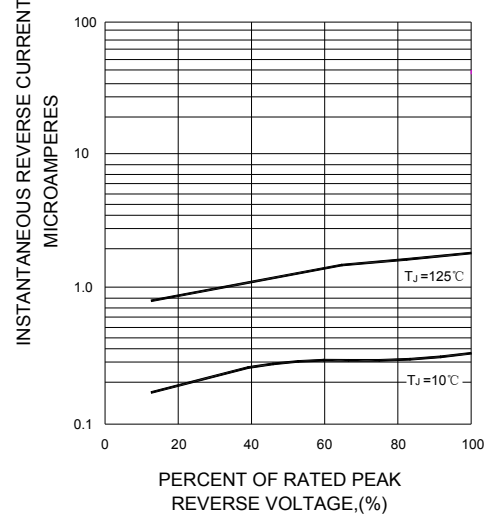

F1G.5-TYPICAL JUNCTION CAPACITANCE

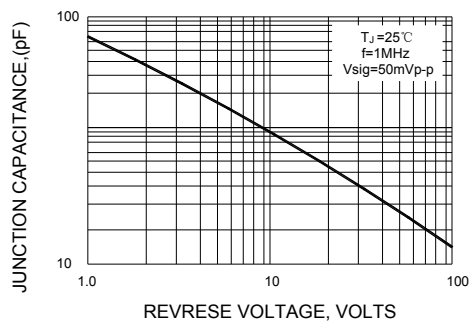

Package Outline Dimensions in inches and millimeters

SMA(DO-214AC)

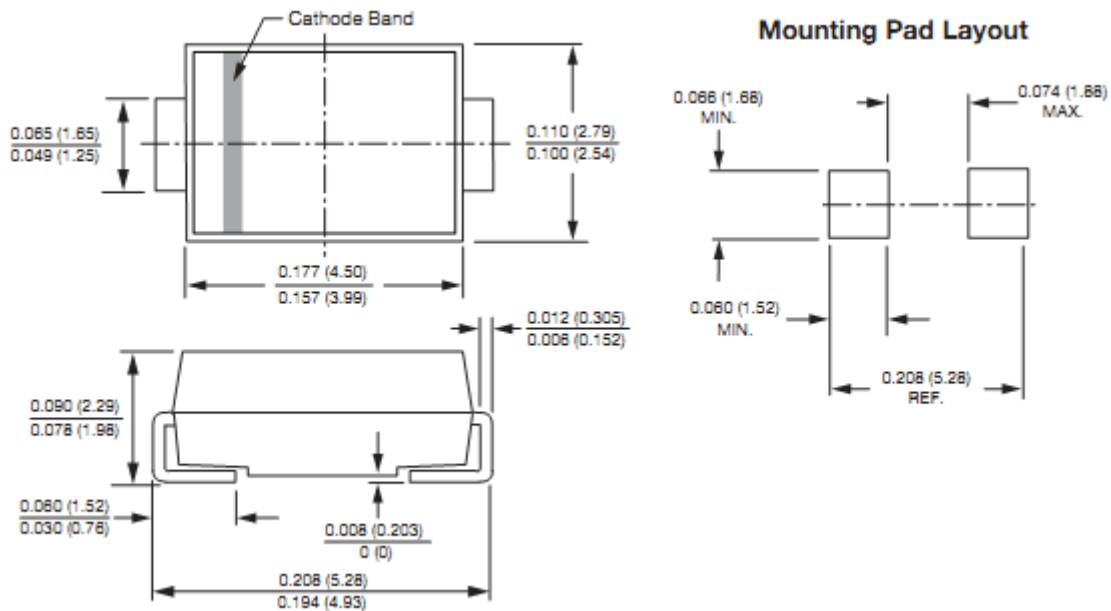

The SINO-IC logo is a registered trademark of ShangHai Sino-IC Microelectronics Co., Ltd.

© 2005 SINO-IC – Printed in China – All rights reserved.

SHANGHAI SINO-IC MICROELECTRONICS CO., LTD

Add: Building 3, Room 3401-03, No.200 Zhangheng Road, ZhangJiang Hi-Tech Park, Pudong, Shanghai 201203, China

Phone: +86-21-33932402 33932403 33932405 33933508 33933608

Fax: +86-21-33932401

Email: webmaster@sino-ic.net

Website: <http://www.sino-ic.net>