

Amphenol PCDSZ
ORIGINAL
PDF Format
R&D

REV	ECN	DESCRIPTION	DATE	MODIFIED
1		PRE-RELEASE	2017.06.20	Jophy.Li
2		UPDATE THE P/N	2017.08.25	Jophy.Li
3		UPDATE DRAWING	2018.01.15	Jophy.Li

安费诺精密连接器(深圳)有限公司
Amphenol PCD Shenzhen

受控文件

2018年1月16日

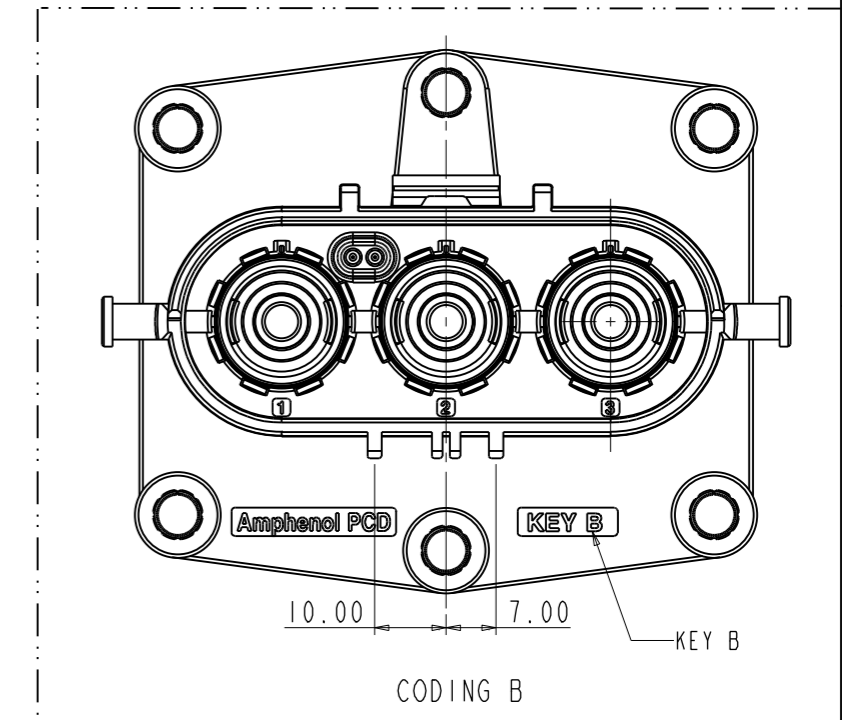
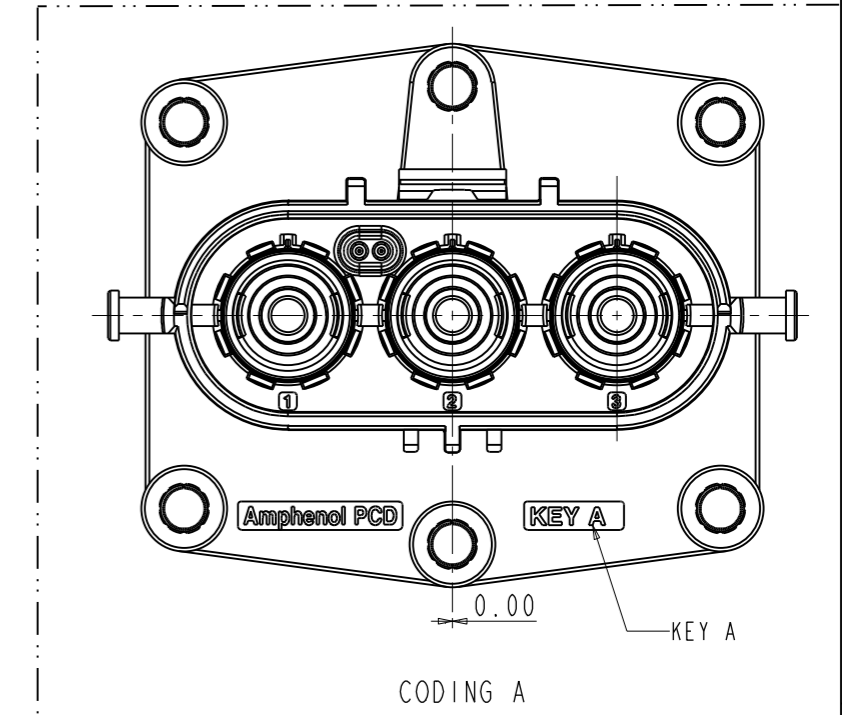
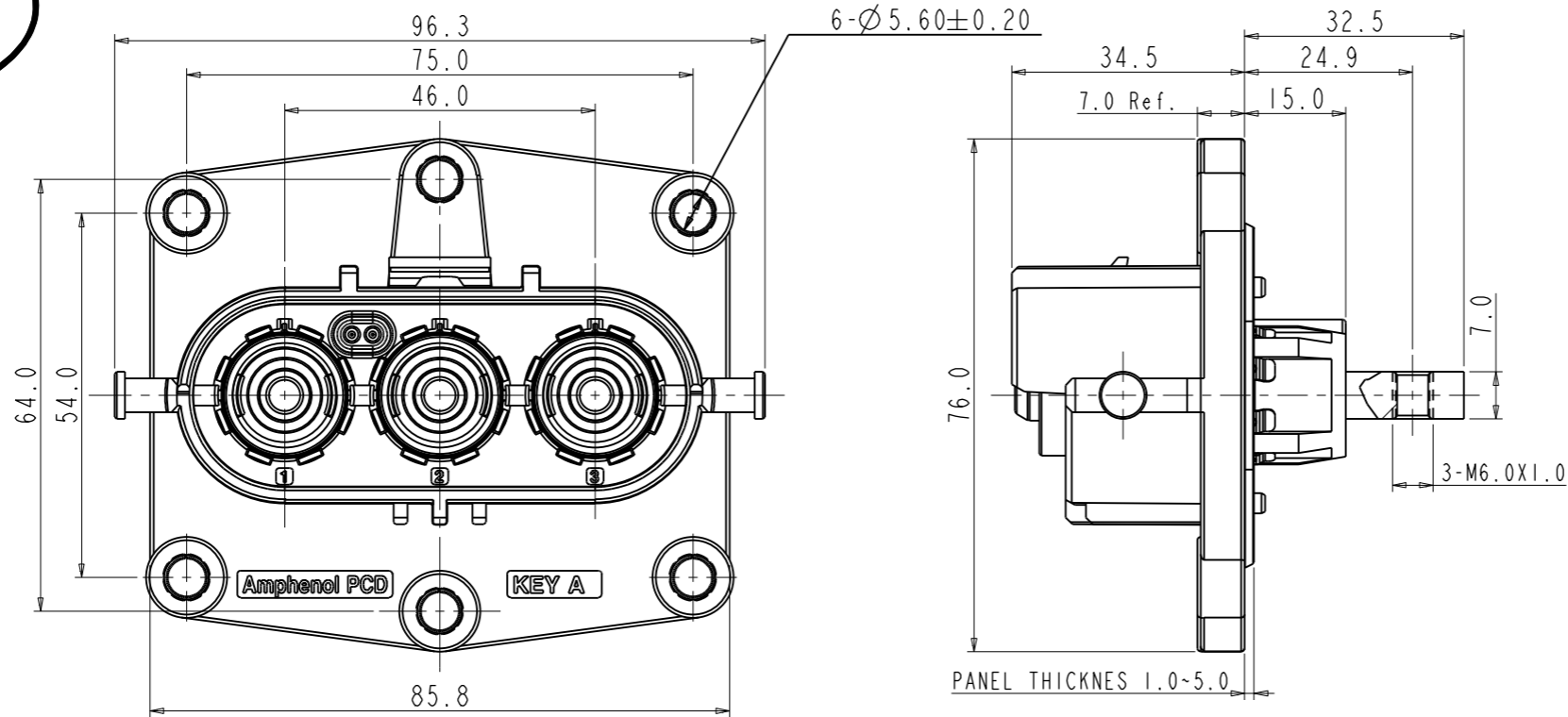

NOTES:

- MATERIAL & FINISH:
PLASTIC BODY: THERMOPLASTICS UL 94V-0 ORANGE COLOR
POWER CONTACT: COPPER ALLOY SILVER PLATED
- HVIL INTERLOCK CABLE SCOPE OF OUTSIDE DIAMETER OD=1.5-2.2mm(0.50-0.75mm² CABLE)
- PART NUMBER DESCRIPTION:
HVSL 800 02 3 X X XX

A: CODING A 0: WITHOUT HVIL H6: HOLE TERMINATION (M6 THREAD)
B: CODING B 1: WITH HVIL D6: SCREW TERMINATION-INTERNAL (M6 THREAD)

3. TECHNICAL DATA TABLE

CURRENT RATE 50mm ² CABLE	180A @ AMBIENT 70°C	+
CURRENT RATE 35mm ² CABLE	150A @ AMBIENT 70°C	+
CURRENT RATE 25mm ² CABLE	120A @ AMBIENT 70°C	+
UL RATING VOLTAGE (OVERVOLTAGE CATEGORY II POLLUTION DEGREE 2)	1000V DC	+
OPERATING TEMPERATURE	-40-125°C	
DIELECTRIC WITH STANDING VOLTAGE	3000V AC	+
INSULATION RESISTANCE	2000MΩ MIN. 25°C, NO CABLE	+
DURABILITY	50 CYCLES	⊙
SHIELDING	YES	⊙
WATERPROOF(MATED CONDITION)	IP67 IP6K9K	+
PROTECTION LEVEL	IP2XB	+
AMBIENT TEMPERATURE	-40-70°C	
TECHNICAL DESCRIPTION	TECHNICAL DATA	FEATURE

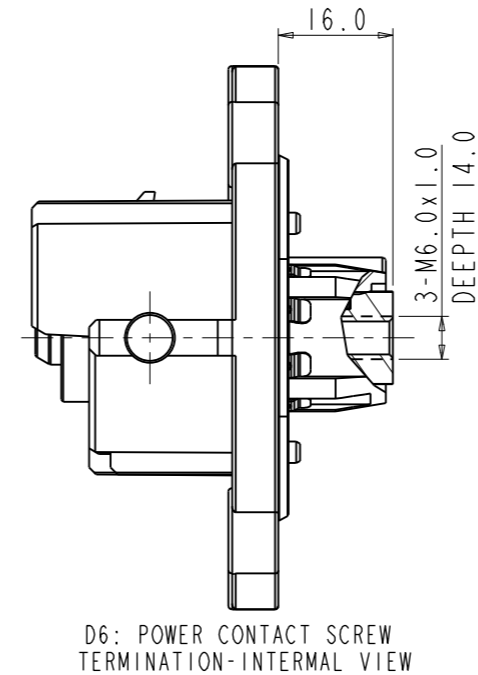
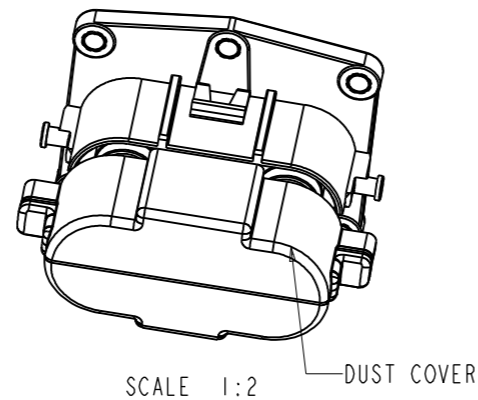

H6: POWER CONTACT HOLE TERMINATION VIEW

D6: POWER CONTACT SCREW TERMINATION-INTERNAL VIEW

DIMENSIONS	TOLERANCES	PROJECTION	Amphenol Pcd Shenzhen	
ANSI Y14.5M	X ±0.5		ENGR	
UNITS: MM	XX ±0.05		Jophy.Li 2018.01.15	
Pro/E FILE	ANGLES ±0.5°		CHKD	
ORIGINAL	THIS DOCUMENT CONTAINS PROPRIETARY INFORMATION WHICH IS THE CONFIDENTIAL PROPERTY OF AMPHENOL PCD SHENZHEN		APPD	
NOT FOR CUSTOMER DISTRIBUTION			Sembao	

TITLE		
HVSLR 800 RECEPTACLE ASSEMBLY 3P TYPE		
SIZE	DWG NO.	REV
A3	C-HVSL800023XXXX	3
CODE: 58982	SCALE: 1:1	SHEET 1 OF 3

C-HVSL800023XXXX

C-HVSL800023XXXX

Amphenol PCDSZ
ORIGINAL
PDF Format
R&D

4. PANEL DRILLING

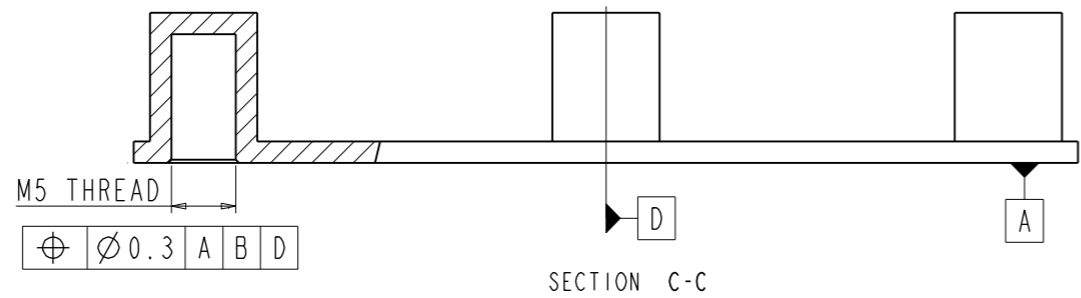

安费诺精密连接器(深圳)有限公司
Amphenol PCD Shenzhen
受控文件
2018年1月16日

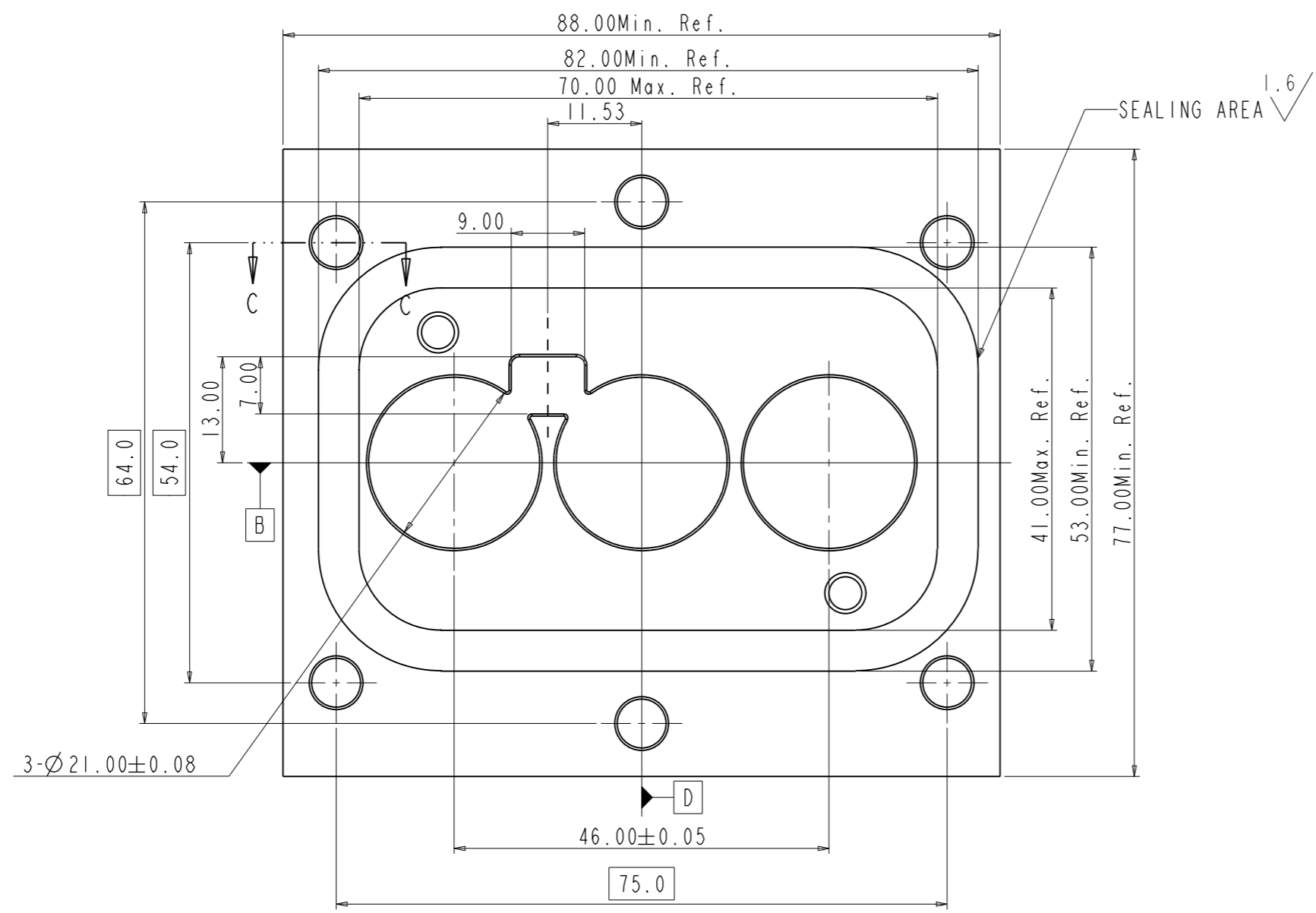
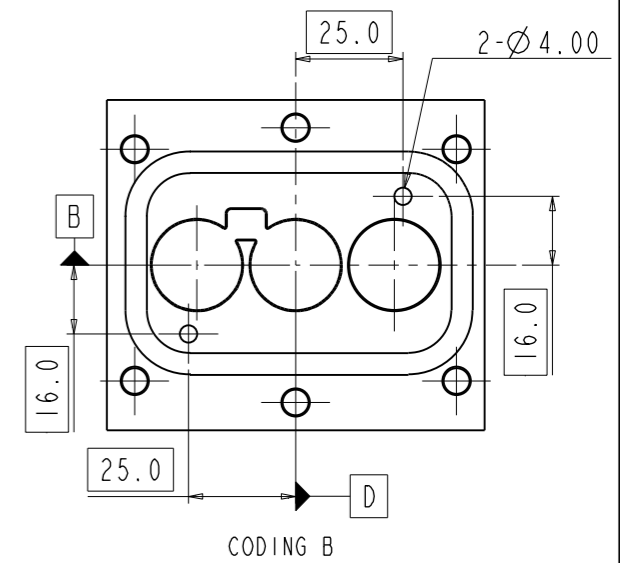
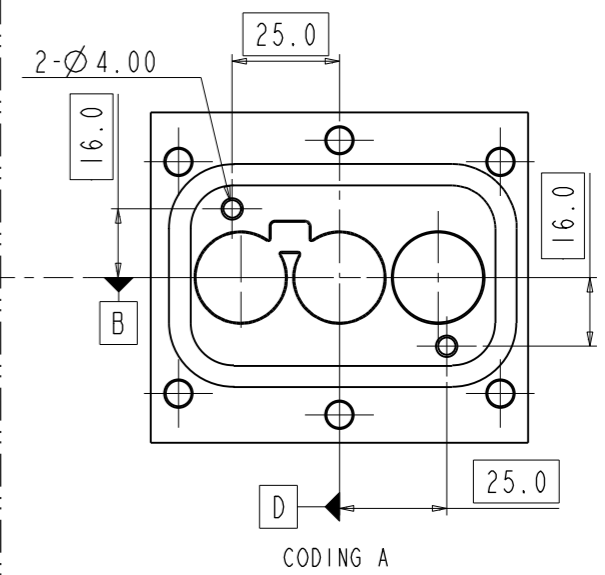

THIS VIEW SHOWING THE KEY "A" DIMENTION
OTHER KEYS REFER THE CODING DESCRIPTION LIST

CODING DESCRIPTION LIST

SIZE	DWG NO.	REV
A3	C-HVSL800023XXXX	3
CODE: 58982	SCALE: 1:1	SHEET 2 OF 3

C-HVSL800023XXXX

C-HVSL800023XXXX

Amphenol PCDSZ
ORIGINAL
PDF Format
R&D

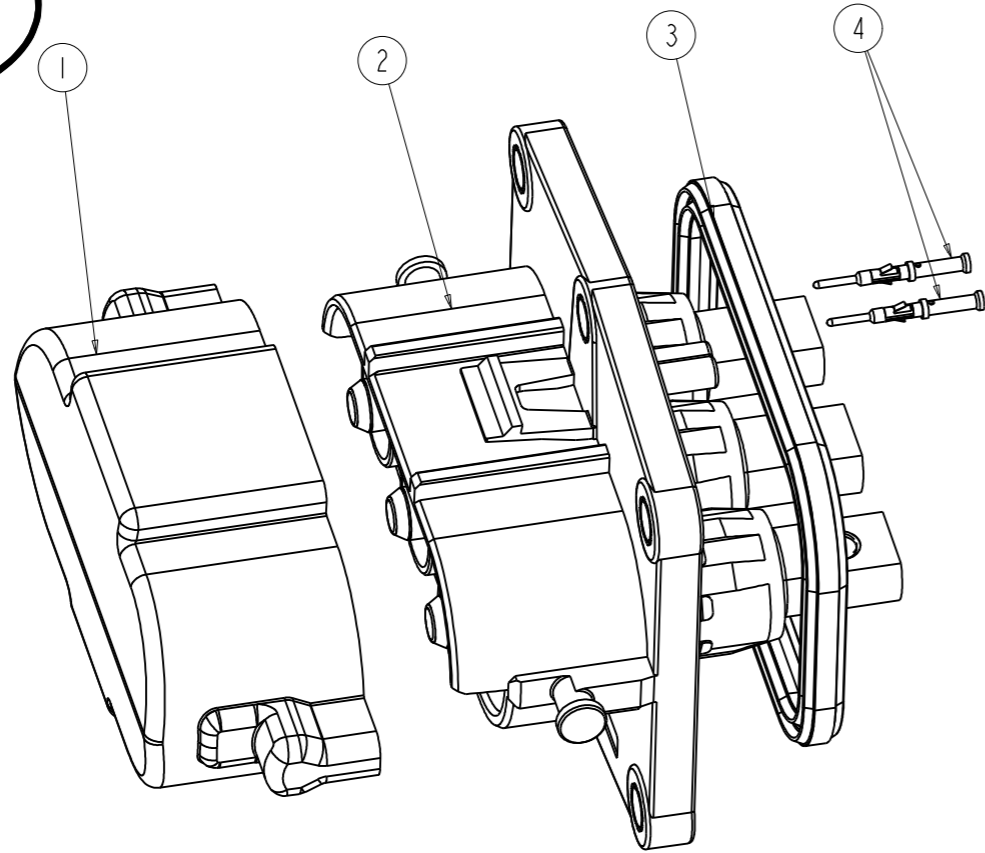

H6: POWER CONTACT
HOLE TERMINATION ASSEMBLE VIEW

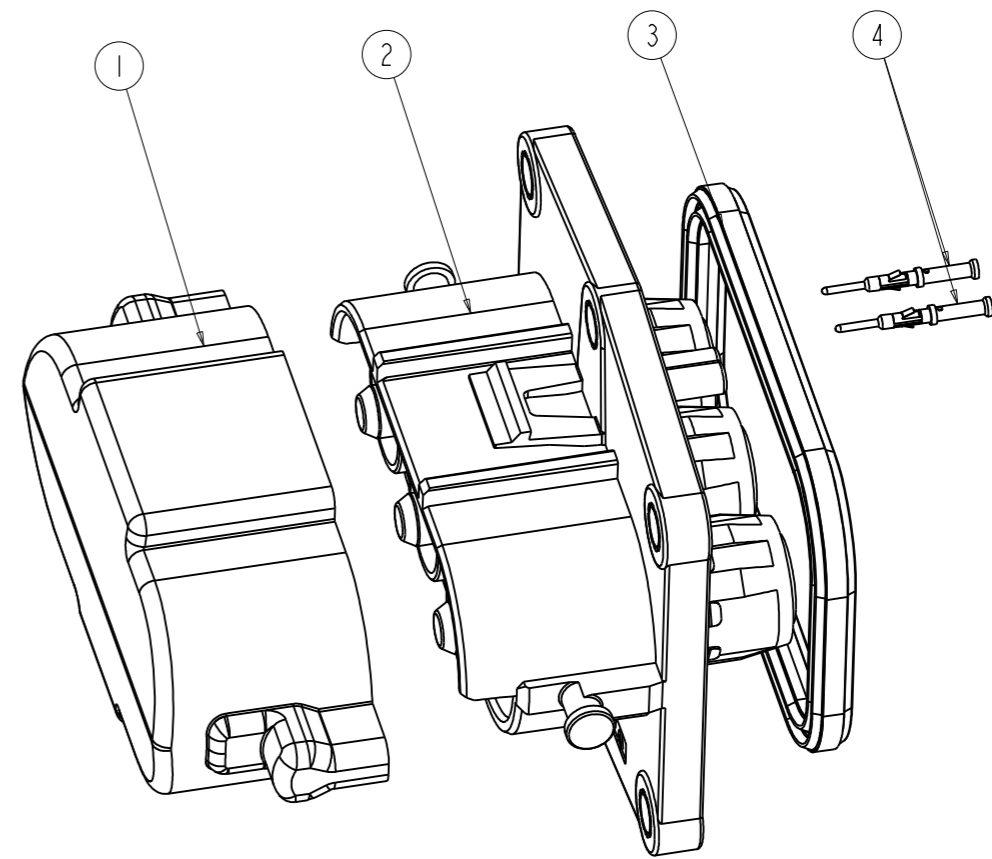

D6: POWER CONTACT SCREW
TERMINATION-INTERNAL ASSEMBLE VIEW

C-HVSL800023XXXX

C-HVSL800023XXXX

5. ASSEMBLY AND DETAIL BOM LIST SHOW

5.1. DETAIL BOM LIST

HVSL800023 X 0D6	3	C427003660	1	FLANGE SEAL PART
	2	D6 MAIN BODY	1	MAIN BODY
	1	C422003555	1	DUST COVER
HVSL800023 X 1D6	4	C420003643	2	1mm MALE CONTACT
	3	C427003660	1	FLANGE SEAL PART
	2	D6 MAIN BODY	1	MAIN BODY
	1	C422003555	1	DUST COVER
HVSL800023 X 0H6	3	C427003660	1	FLANGE SEAL PART
	2	H6 MAIN BODY	1	MAIN BODY
	1	C422003555	1	DUST COVER
HVSL800023 X 1H6	4	C420003643	2	1mm MALE CONTACT
	3	C427003660	1	FLANGE SEAL PART
	2	H6 MAIN BODY	1	MAIN BODY
	1	C422003555	1	DUST COVER
PART NUMBER	ITEAM	COMPONENT P/N	QUANTITY	DESCRIPTION

安费诺精密连接器(深圳)有限公司
Amphenol PCD Shenzhen

受控文件

2018年1月16日

SIZE	DWG NO.	REV
A3	C-HVSL800023XXXX	3
CODE: 58982	SCALE: 1:1	SHEET 3 OF 3