

## Low Noise, DC/DC Charge Pump Regulator

### Description

The FP6770 is a low noise DC/DC charge pump regulator that produces a regulated output voltage from 2.7V to 4.5V input voltage. Low external parts count (one flying capacitor and two small bypass capacitors at  $V_{IN}$  and  $V_{OUT}$ ) make the FP6770 ideal for small, battery-powered applications.

The FP6770 operates as a constant frequency mode switched capacitor voltage doubler to produce a regulated output and reduces both output and input ripple. The FP6770 has both short circuit protection and thermal shutdown capability.

The FP6770 is available in space-saving SOT-23-6 TSOT-23-6 and TDFN-6 packages.

### Features

- Low Noise Constant Frequency Operation
- Output Current: Minimum 170mA at  $V_{IN}=3.2V$
- Available in SOT-23-6, TSOT-23-6 and TDFN-6
- 2MHz Switching Frequency
- Fixed  $5V \pm 4\%$  Output
- $V_{IN}$  Range: 2.7V to 4.5V
- No Inductors
- Low Shutdown Current:  $<1\mu A$

### Applications

- White LEDs Backlighting
- Li-Ion Battery Backup Supplies
- Smart Card Readers
- Local 3V to 5V Conversion
- PCMCIA Local 5V Supplies

### Pin Assignments

#### S6 Package (SOT-23-6)

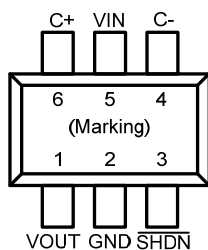

#### S9 Package (TSOT-23-6)

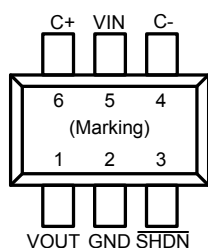

#### WD Package (TDFN-6) (1.6x1.6mm)

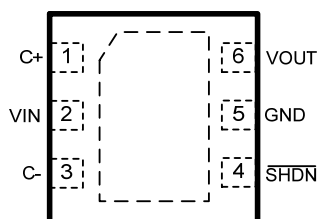
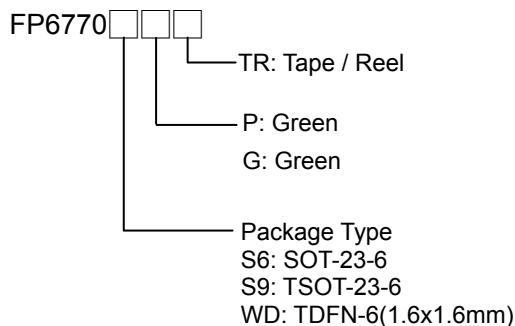

Figure 1. Pin Assignment of FP6770

### Ordering Information



#### SOT-23-6 Marking

Part Number	Product Code
FP6770S6P	C2

#### TSOT-23-6 Marking

Part Number	Product Code
FP6770S9P	C0

#### TDFN-6(1.6x1.6mm) Marking

Part Number	Product Code
FP6770WDG	P.

**Typical Application Circuit**

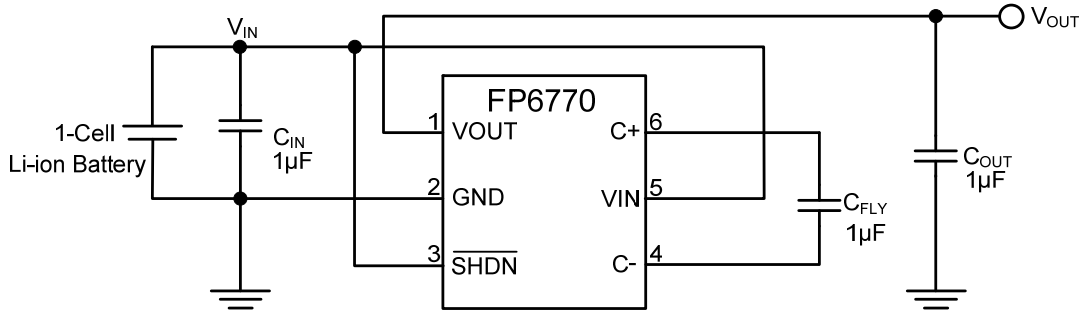

Figure 2. Typical Application Circuit of FP6770

**Functional Pin Description**

Pin Name	Pin Function
<b>VOUT</b>	Regulated output voltage. For best performance, $V_{OUT}$ should be bypassed with a $1\mu F$ (min.) low ESR capacitor as close as possible to the pin.
<b>GND</b>	Ground. Should be tied to a ground plane for best performance.
<b><math>\overline{\text{SHDN}}</math></b>	Active low shutdown input. A low voltage on $\overline{\text{SHDN}}$ disables the FP6770. $\overline{\text{SHDN}}$ is not allowed to float.
<b>C-</b>	Flying capacitor negative terminal.
<b>VIN</b>	Input supply voltage. $V_{IN}$ should be bypassed with a $1\mu F$ (min.) low ESR capacitor.
<b>C+</b>	Flying capacitor positive terminal.

**Block Diagram**

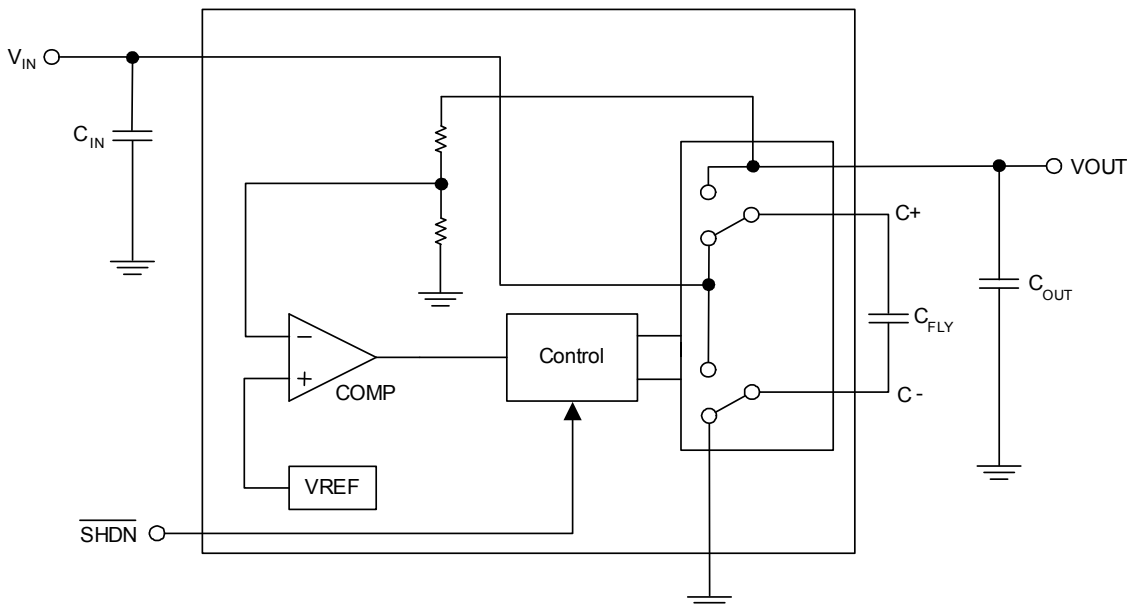

Figure 3. Block Diagram of FP6770

## Absolute Maximum Ratings

- $V_{IN}$  to GND----- 6V
- $V_{OUT}$  to GND----- 6V
- All Other Pins to GND----- 6V
- Power Dissipation ( $P_D$ ) @  $T_A=25^\circ\text{C}$ :
  - SOT-23-6 / TSOT-23-6 ----- 0.4W
  - TDFN-6 (1.6mX1.6m)( $P_D$ )----- 1.25W
- Package Thermal Resistance:
  - SOT-23-6 / TSOT-23-6 ( $\theta_{JA}$ )----- 250°C/W
  - TDFN-6(1.6mX1.6m)----- 80°C/W
- Junction Temperature----- 150°C
- Storage Temperature Range----- -65°C to 150 °C
- Lead Temperature (Soldering, 10 sec.) ----- 260°C

Note : Stresses beyond those listed under "Absolute Maximum Ratings" may cause permanent damage to the device.

## Recommended Operating Conditions

- Supply Voltage ( $V_{IN}$ ) ----- (2.7V to 4.5V)  $\pm 10\%$
- Operation Temperature Range----- -40°C to +85°C

## Electrical Characteristics

( $T_A=25^\circ\text{C}$ ,  $C_{FLY}=1\mu\text{F}$ ,  $C_{IN}=1\mu\text{F}$ ,  $C_{OUT}=1\mu\text{F}$ , unless otherwise specified.)

Parameter	Symbol	Conditions	Min	Typ	Max	Unit
Input Voltage	$V_{IN}$		2.7		4.5	V
Output Voltage	$V_{OUT}$	$2.7V \leq V_{IN} < 4.5V$ , $I_{OUT} \leq 60\text{mA}$	4.8	5	5.2	V
		$3.0V \leq V_{IN} \leq 4.5V$ , $I_{OUT} \leq 120\text{mA}$	4.8	5	5.2	V
Continuous Output Current	$I_{OUT}$	$V_{IN}=3.0V$ , $V_{OUT}=5.0V$ , $\overline{SHDN}=V_{IN}$	100			mA
Supply Current	$I_{CC}$	$2.7V \leq V_{IN} \leq 5.0V$ , $I_{OUT}=0$ , $\overline{SHDN}=V_{IN}$		3	4.5	mA
Shutdown Current	$I_{\overline{SHDN}}$	$2.7V \leq V_{IN} \leq 5.0V$ , $I_{OUT}=0$ , $\overline{SHDN}=0V$		0.01	1.0	$\mu\text{A}$
Efficiency	$\eta$	$V_{IN}=2.7V$ , $I_{OUT}=60\text{mA}$		90		%
Switching Frequency	$f_{OSC}$	Oscillator Free Running		2		MHz
/SHDN Input Threshold	$V_{IH}$	$V_{IN}=3.0V$ , output on	1.4			V
	$V_{IL}$	$V_{IN}=3.0V$ , output off			0.3	V
/SHDN Leakage Current	$I_{IH}$	$\overline{SHDN}=V_{IN}$	-1		1	$\mu\text{A}$
	$I_{IL}$	$\overline{SHDN}=0V$	-1		1	$\mu\text{A}$
$V_{OUT}$ Turn On Time	$t_{ON}$	$V_{IN}=3V$ , $I_{OUT}=1\text{mA}$		200		$\mu\text{s}$
Output Short Circuit Current	$I_{SC}$	$V_{IN}=3V$ , $V_{OUT}=0V$ , $\overline{SHDN}=V_{IN}$		300		mA

**Typical Performance Curves**

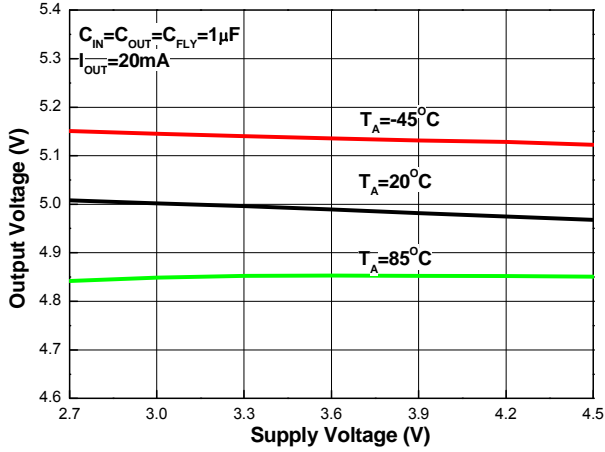

Figure 4. Output Voltage vs. Supply Voltage

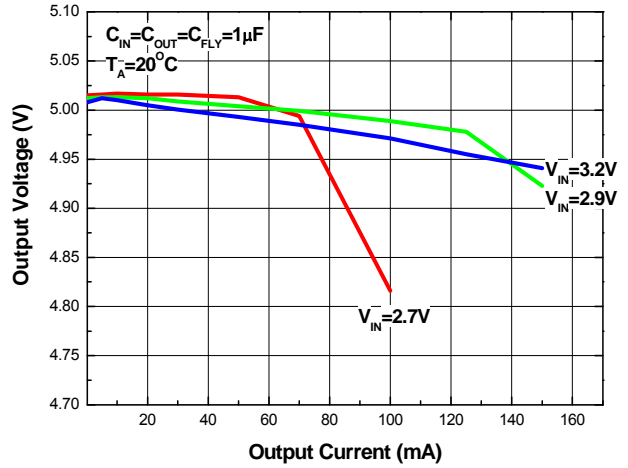

Figure 5. Output Voltage vs. Load Current

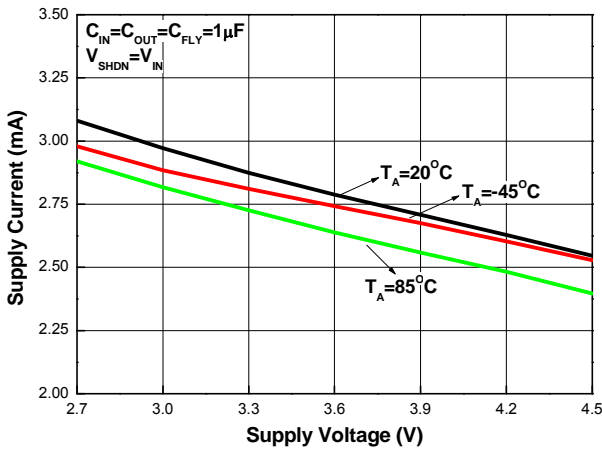

Figure 6. No Load Supply Current vs. Supply Voltage

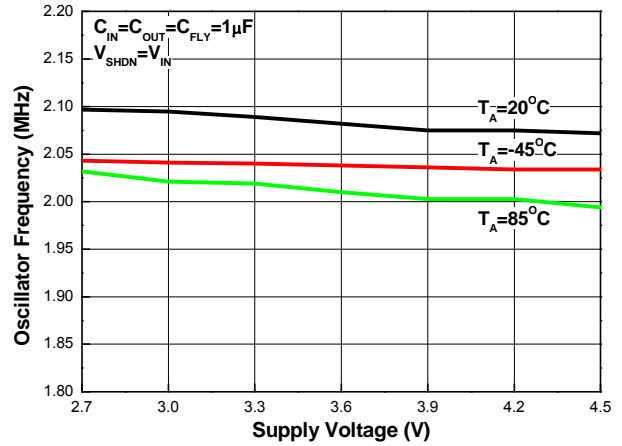

Figure 7. Oscillator Frequency vs. Supply Voltage

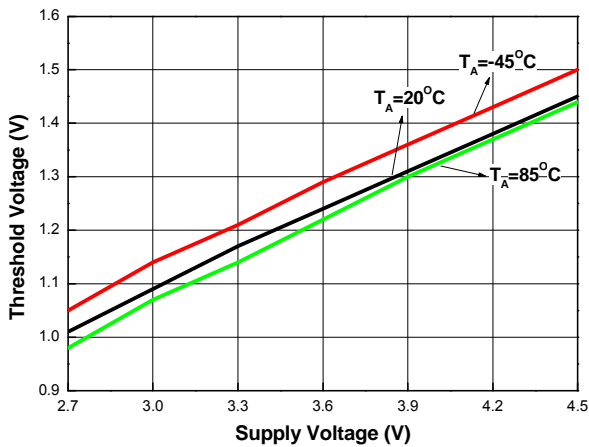

Figure 8. VSHDN Threshold Voltage vs. Supply Voltage

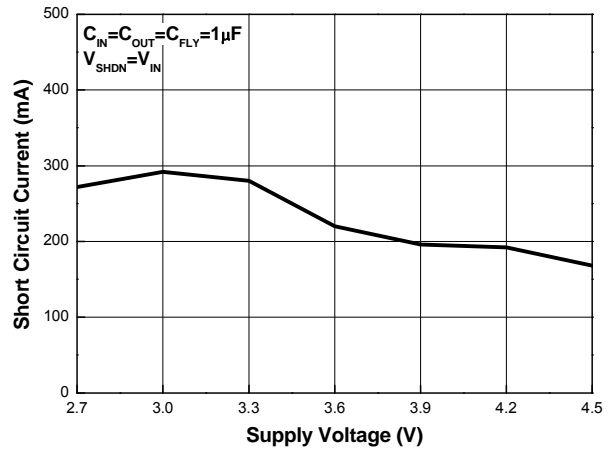

Figure 9. Short Circuit Current vs. Supply Voltage

### Typical Performance Curves (Continued)

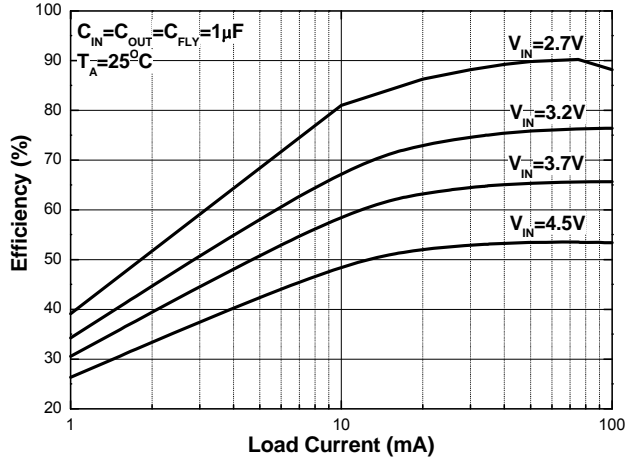

Figure 10. Efficiency vs. Load Current

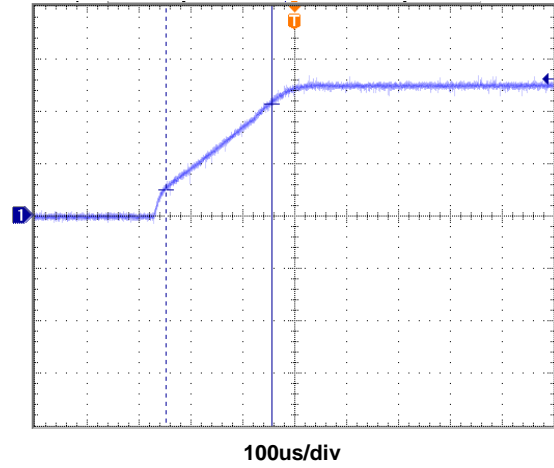

Figure 11. Output Voltage Start Up

## Application Information

### Introduction

The FP6770 is a DC/DC charge pump converter that produces a regulated 5V output with an input voltage that range from 2.7V to 4.5V. It boosts  $V_{IN}$  to get a regulated output voltage using the charge pump topology. Sensing the output voltage through an internal resistor divider. When the output voltage is lower, the internal comparator will increase charge pump ability, and vice versa. When the charge pump is enabled, a two-phase non-overlapping clock activates the charge pump switches.

### Efficiency

Let's take advantage of conversation of charge for flying capacitor. Assume that the flying capacitor has reached its steady state.

$$I_{ON-AVE} = I_{OFF-AVE} \dots\dots\dots(1)$$

According to the equation (1), the input current is twice the output current.

$$\begin{aligned} I_{IN} &= I_{ON-AVE} + I_{OFF-AVE} \\ &= 2I_{OFF-AVE} \\ &= 2I_{OUT} \end{aligned}$$

The efficiency of charge pump is given below:

$$\eta = \frac{V_{OUT} \times I_{OUT}}{V_{IN} \times I_{IN}} = \frac{V_{OUT} \times I_{OUT}}{V_{IN} \times 2I_{OUT}} = \frac{V_{OUT}}{2V_{IN}}$$

### Short Circuit/Thermal Protection

FP6770 have a built-in short circuit current limiting and an over temperature protection. During the short circuit condition, the output current is automatically limited at approximately 300mA on  $V_{IN}=3V$ . When the die temperature exceeds 160°C, the thermal protection will shut the charge pump switching operation down and the die temperature will reduce afterwards. When the die temperature drops below 135°C, the charge pump switching circuit will restart. If the fault doesn't eliminate, the above protecting operation will repeat again and again. It allows FP6770 to continuously work at short circuit condition without damaging the device.

### Shutdown

The output is disconnected from input when /SHDN pin is tied to GND. In shutdown mode, most circuit is turned off and the input current gets extremely low. Due to high impedance, /SHDN pin can't be floated.

### External Capacitor Selection

Three external capacitors determine FP6770 performances, in the aspects of output ripple voltage, charge pump strength and transient. Optimum performance can be obtained by the use of ceramic capacitors with low ESR.

Because a low ESR ceramic capacitor can reduce noise and ripple, ceramic capacitor is recommended for  $C_{IN}$  and  $C_{OUT}$ . The value of  $C_{OUT}$  determines the amount of output ripple voltage. An output capacitor with larger value results in smaller ripple.

$C_{FLY}$  determine the strength of charge pump. The larger  $C_{FLY}$  means that the larger output current and larger ripple voltage on  $V_{OUT}$  pin. However, large  $C_{IN}$  and  $C_{OUT}$  are expected when a large  $C_{FLY}$  applies.

The value of capacitors, which is used under operation condition, determines the performance of a charge pump converter. And two factors, as follows, affect the capacitance of capacitor.

There are many kinds of Ceramic capacitors materials, such as X7R, X5R, Z5U and Y5V. There have different ESR, tolerance in temperature and different capacitance loss

For example, a X7R or X5R type of capacitor can retain most of the capacitance at temperature from -40°C to 85°C, but a Z5U or Y5V type will lose most of the capacitance at that temperature range.

### Layout Considerations

Because the high frequency and high transient current of FP6770, careful consideration of PCB layout. Minimize the distance between every component,  $C_{FLY}$  and  $C_{OUT}$  especially. It also minimizes every connection length with a maximum trace width to achieve the best performance of FP6770. Make sure each device connects to immediate ground plane.

**Outline Information**

**TSOT-23-6 Package (Unit: mm)**

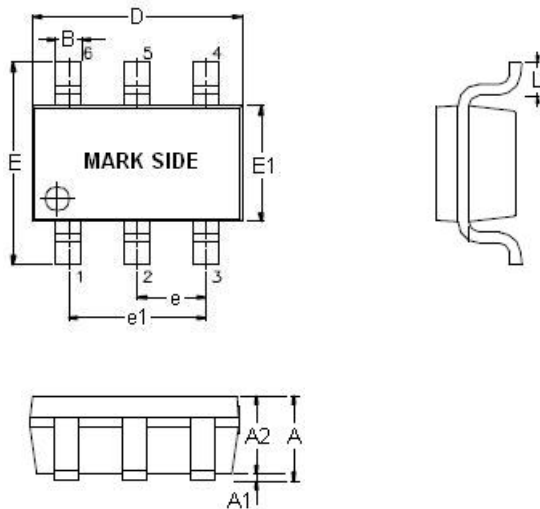

SYMBOLS UNIT	DIMENSION IN MILLIMETER	
	MIN	MAX
A	0.75	0.90
A1	0.00	0.10
A2	0.71	0.80
B	0.35	0.50
D	2.80	3.00
E	2.60	3.00
E1	1.50	1.70
e	0.90	1.00
e1	1.80	2.00
L	0.35	0.55

Note : Followed From JEDEC MO-193-C.

**SOT-23- 6 Package (Unit: mm)**

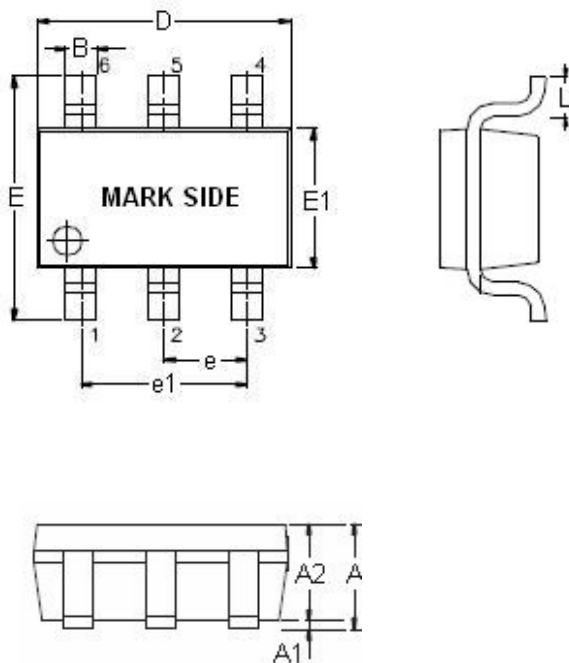

SYMBOLS UNIT	DIMENSION IN MILLIMETER	
	MIN	MAX
A	1.00	1.20
A1	0.00	0.10
A2	1.00	1.10
B	0.35	0.50
D	2.80	3.00
E	2.60	3.00
E1	1.50	1.70
e	0.90	1.00
e1	1.80	2.00
L	0.35	0.55

Note : Followed From JEDEC MO-178-C.

**Outline Information (Continued)**

**TDFN- 6 1.6mmX1.6mm Package (Unit: mm)**

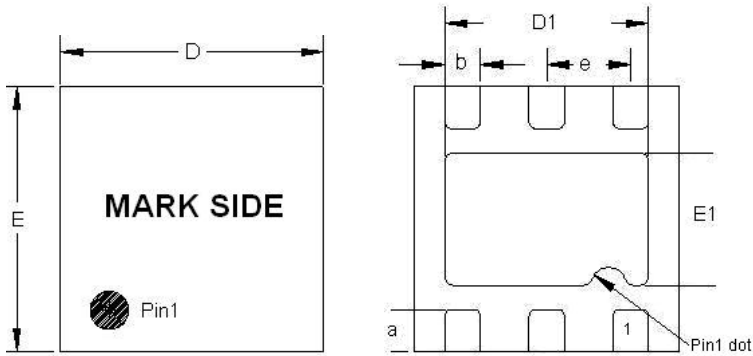

SYMBOLS UNIT	DIMENSION IN MILLIMETER	
	MIN	MAX
A	0.70	0.80
A1	0.00	0.05
A2	0.18	0.25
D	1.55	1.65
E	1.55	1.65
a	0.18	0.30
b	0.18	0.30
e	0.45	0.55
D1	0.95	1.05
E1	0.55	0.65

Note :Followed From JEDEC MO-229-C

**Life Support Policy**

Fitipower's products are not authorized for use as critical components in life support devices or other medical systems.