

SECTION A-A

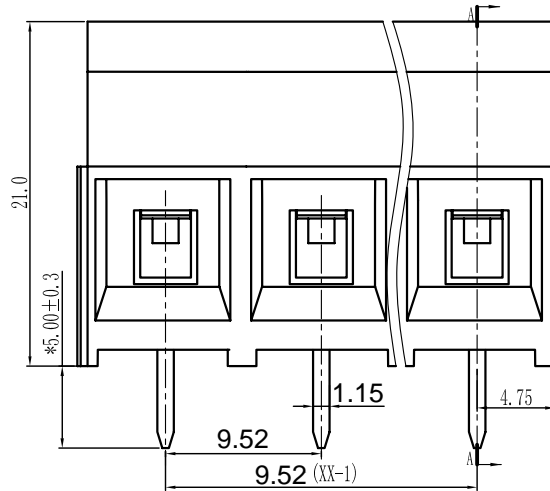

### 电气性能/Electrical

- 参考标准/Standard: UL IEC
- 额定电压/Rated voltage: 300V 250V
- 额定电流/Rated current: 30A 35A
- 接触电阻/Contact resistance:  $20m\Omega$
- 使用线径/Wire range: 26-10AWG  $6.0mm^2$
- 耐电压/Withstanding voltage: AC2000V/1Min
- 绝缘电阻/Insulation resistance:  $500M\Omega/DC500V$

### 机械性能/Mechanical

- 温度范围/Temp.Range:  $-40^{\circ}C \sim +105^{\circ}C$
- 扭矩/Torque: 0.5Nm (4.5lb`in)
- 剥线长度/Strip length: 6-7mm

### 尺寸/Dimensions

- 间距/Pitch: 9.5mm
- 极数/Poles: 2P-24P

### 材质及电镀/Material

- 塑件/Housing: PA66, UL94V-0
- 螺丝/Screws: M3.0, steel Zinc plated
- 方块/Cage: Brass, Ni plated
- 焊脚/Pin header: Brass, Snle plated

订购方式:  
HOW TO ORDER

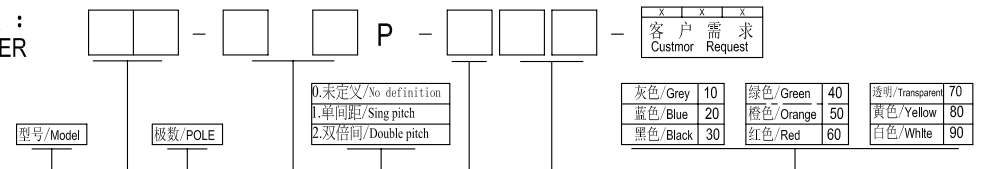

linear dimension (Tolerances Standard GB/T 14486-2008)											≡	—	□	//	⊥	
variable range	to 6	over 6 to 10	over 10 to 18	over 18 to 30	over 30 to 50	over 50 to 80	over 80 to 120	over 120 to 160	over 160 to 200	over 200 to 250	over 250 to	all	to 5	over 5 to 30	over 30 to 120	over 120 to
tolerance	±0.1	±0.14	±0.19	±0.25	±0.32	±0.43	±0.57	±0.72	±0.88	±1.05	±1.25	0.5	0.025	0.06	0.12	0.4

单位/UNITS	mm	尺寸/SIZE	A4	比例/SCALE	比例	第一视角/THIRD ANGLE PROJECTION	
Cixi Dibo Electronics Co.,LTD						名称/NAME	DB910-9.52-XXP