

Specification

SGL8022K

Two-Channel Touch Control Chip

Version 1.6

Contents

1. GENERAL DESCRIPTION.....	3
2. FEATURES	3
3. PACKAGING AND PIN ASSIGNMENT	4
4. PACKAGING INFORMATION	5
5. APPLICATION CIRCUIT.....	6
6. ELECTRICAL CHARACTERISTICS.....	7
7. BOM TABLE	7

1. GENERAL DESCRIPTION

SGL8022K is a two-channel capacitive touch chip with two logic-control output.

- Realization of logical function by a touch operation. Low operational difficulty and convenient.
- High applicability. Touching function is still effective with the existence of medium (such as glass, acrylic, plastic, ceramic, etc.) isolation.
- Wide range of applied voltage, which could be chosen optionally within 2.4V~5.5V.
- Low cost. SGL8022K could be driven by a simple peripheral circuit, easy to machining.
- High stability and good anti-interference property. SGL8022K has a value of EFT over $\pm 2\text{KV}$. Under the interference of mobile phones which exist in a near-field and multi-angle situation, the touching sensitivity and response time of SGL8022K proves to be fine.

2. FEATURES

- ◆ The initial state of pin LO1 and LO2 after electrified depend on the input state of pin OSC before power on. Pin LO1 and LO2 output high level after power on if pin OSC is connected to VDD(High Level); pin LO1 and LO2 output low level after power on if pin OSC is connected to GND(Low Level),
- ◆ A touch operation input through TI1 corresponds to logic output of LO1; a touch operation input through TI2 corresponds to logic output of LO2.
- ◆ A press operation on TI1 or TI2 corresponds to the reversal of the logic output of LO1 or LO2; the state reverts to initial state after the release

3. PACKAGING and PIN ASSIGNMENT

DIP8

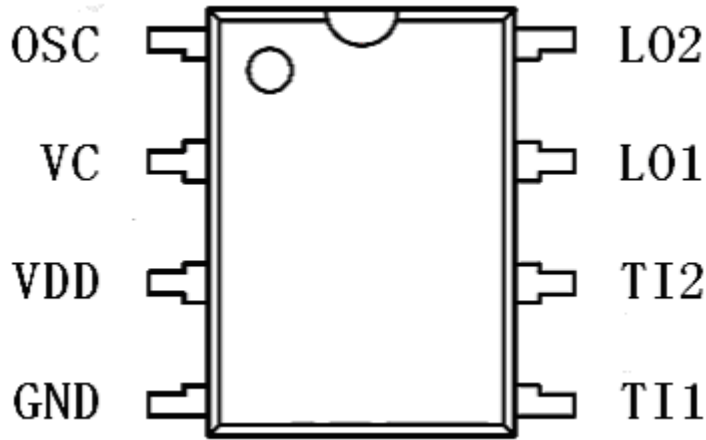

SOP8

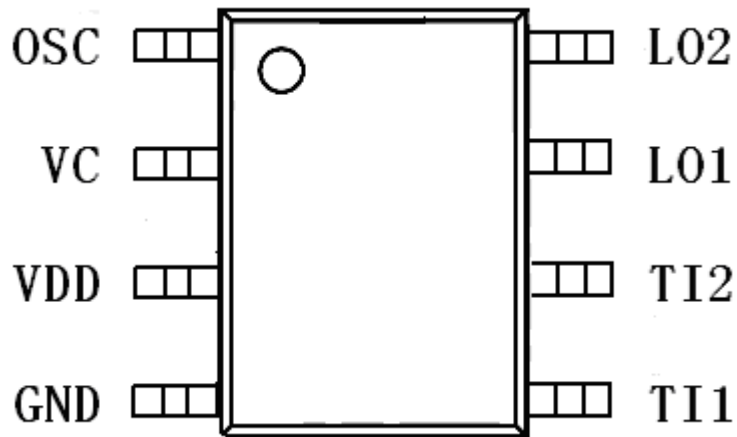

Pin number	Pin name	Input/Output	Functional Specification
1	OSC	Input	functional optipn
2	VC	Input	sampling capacitor input
3	VDD	Source	positive electrical source
4	GND	Source	negative electrical source
5	TI1	Input	touch input
6	TI2	Input	touch input
7	LO1	Output	control output
8	LO2	Output	control output

4. PACKAGING INFORMATION

DIP8

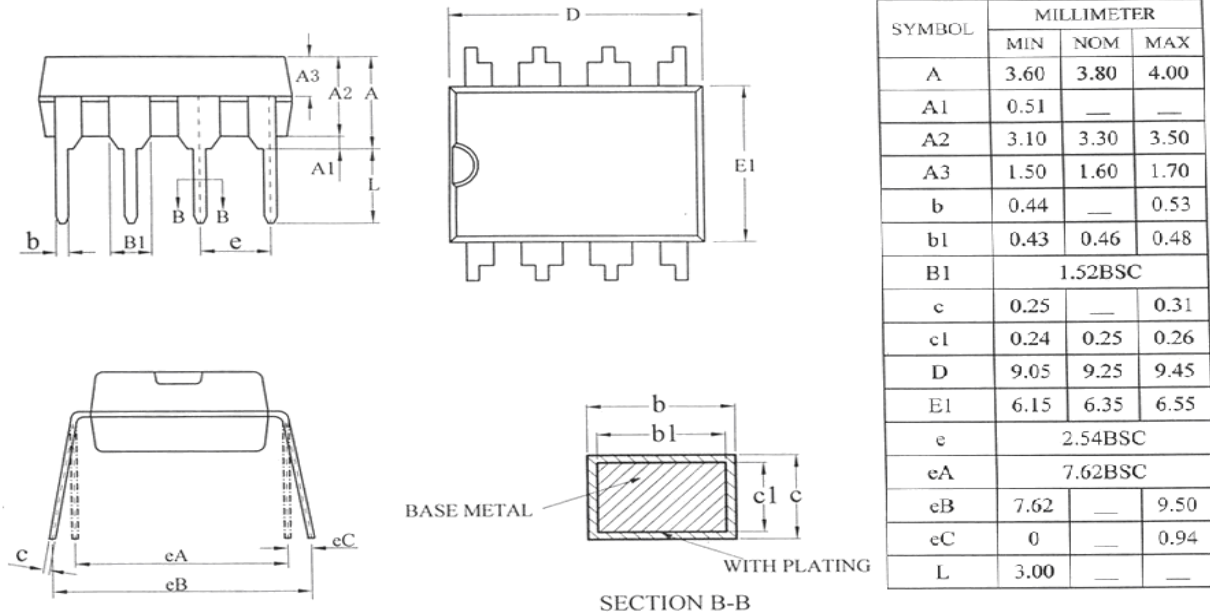

SOP8

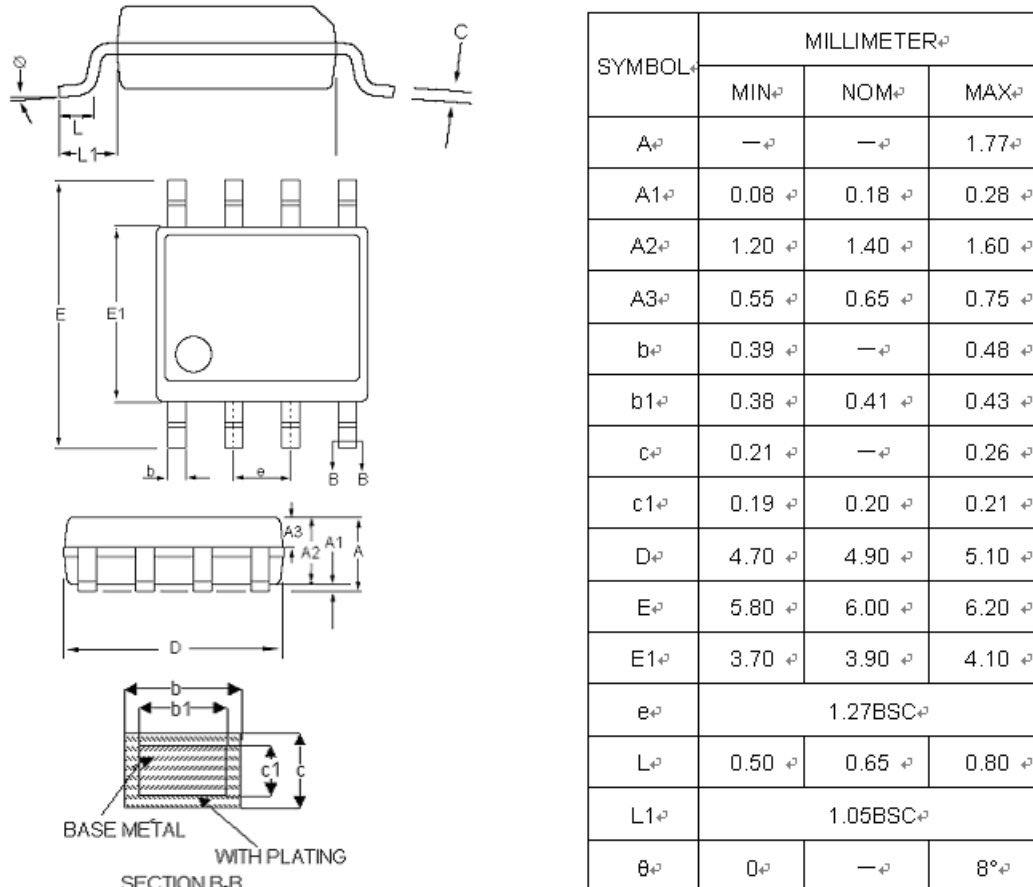

5. APPLICATION CIRCUIT

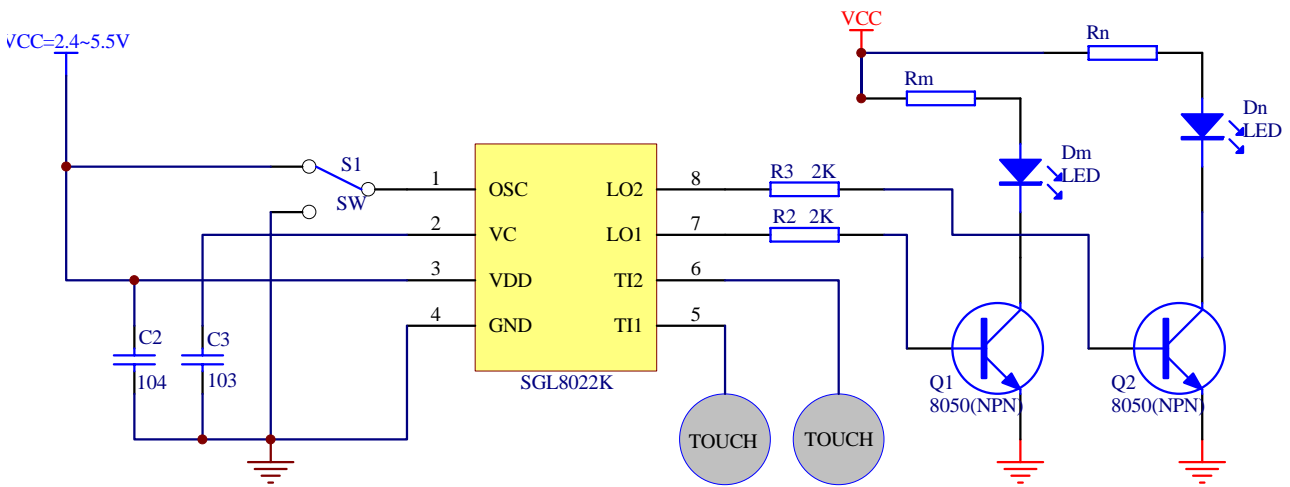

Note: The touching sensitivity could be regulated by modifying the value of C3 (the sampling capacitor between VC and GND). when the difference practical medium material and medium in the form,

Medium Types	C3 (sampling capacitor between VC and GND)	
	Capacitor Types	Capacitance
metallic shell	333 terylene capacitor	0.033uF/25V
3mm arcrylic glass	103 terylene capacitor	0.01uF/25V
3-6mm arcrylic glass	203 terylene capacitor	0.02uF/25V
6-10mm arcrylic glass	473 terylene capacitor	0.047uF/25V

6. ELECTRICAL CHARACTERISTICS

Parameter Name	Typical Value	Unit
work voltage	3.0	V
work current	60	uA
Standby current	8	uA
input (high level)	(2/3)VDD	V
input (Low level)	(1/3)VDD	V
output (high level)	7	mA
output (low level)	10	mA
work temperature	-20~70	°C
storage temperature	-50~100	°C

7. BOM Table

Device Symbol	Device Name	Device Value
R2	carbon film resistor	2KΩ/0.25W
R3	carbon film resistor	2KΩ/0.25W
Rm	carbon film resistor	depend on situation
Rn	carbon film resistor	depend on situation
C2	ceramic capacitor	0.1uF/25V
C3	ceramic capacitor	0.01uF/25V
C4	electrolytic capacitor	10 uF
U1	LDO	3.3V
Q1	NPN transistor	8050
Q2	NPN transistor	8050
Dm	LED	LED
Dn	LED	LED