

# APPROVAL SHEET

To :

Customer P/N :

UDE P/N : RB1-125BAK1A

Description : RJ45 1X1 Tab Down  
Through Hole  
10/100/1000 Base-T  
Contact Area : Gold Flash  
LED: L-Green ; R-Yellow



Spec No.  
RB1686-PX

Update Date  
2017/5/16

Revision  
B

Approved	Checked	Prepared



湧德電子 股份有限公司  
UDE Corp.

桃園市(33852) 蘆竹區內溪路 68 巷13號

No.13, Ln. 68, Neixi Rd., Luzhu Dist., Taoyuan City (33852), Taiwan

TEL: 886-3-3242000 FAX: 886-3-3246611

<http://www.ude-corp.com/>

1. MECHANICAL DIMENSION

1.1 Product Dimension

Unit:mm	General Tolerance :	X.X : ± 0.38
		X.XX : ± 0.20

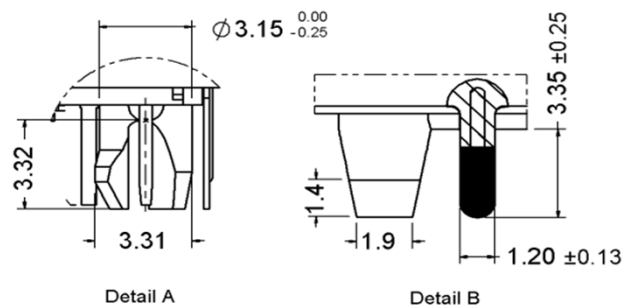
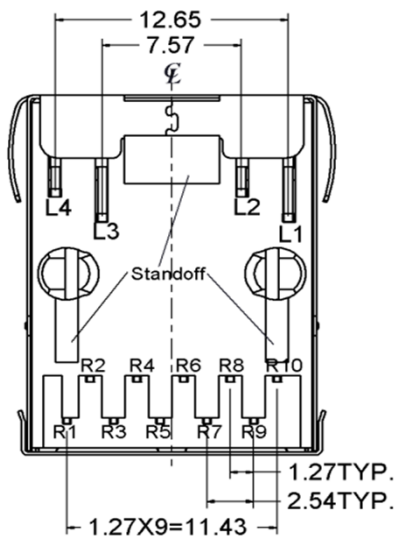
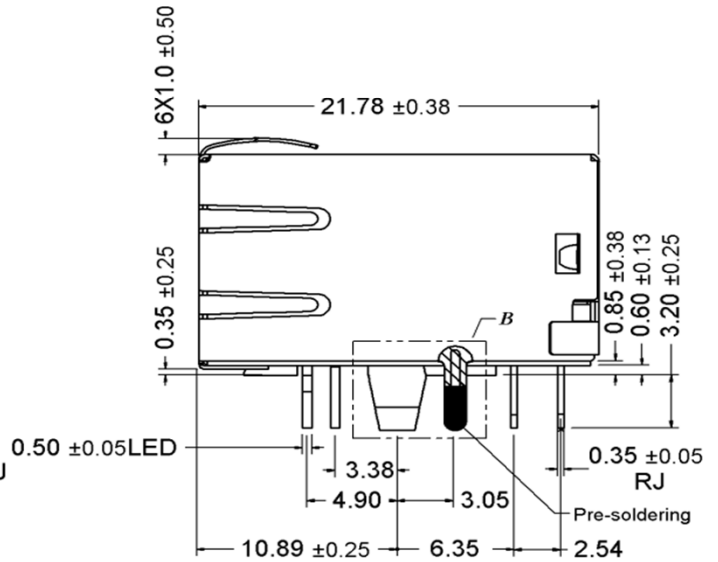
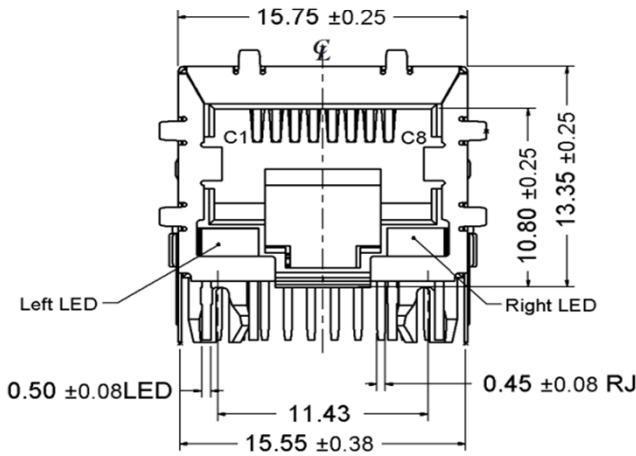
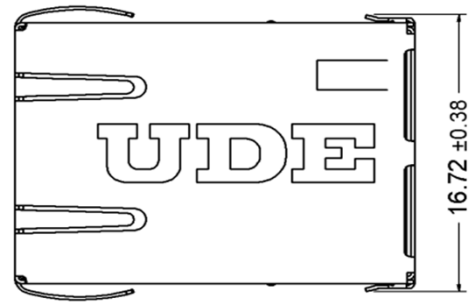
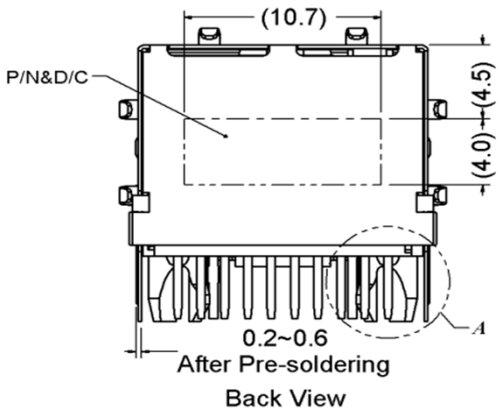

1.2 Recommended PCB Layout

Component Side of Board

All dimension tolerance are  $\pm 0.05\text{mm}$  unless otherwise specified

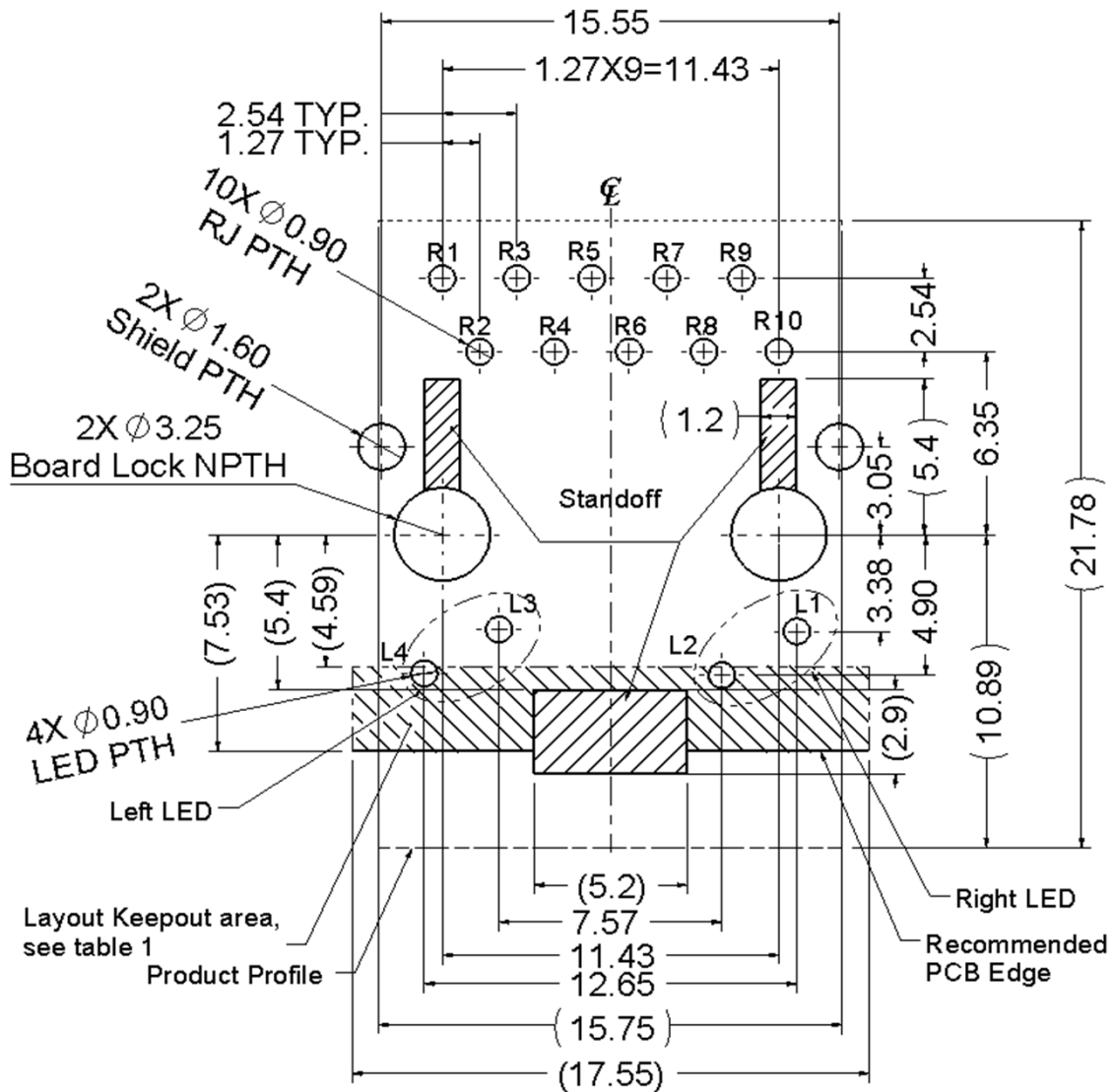
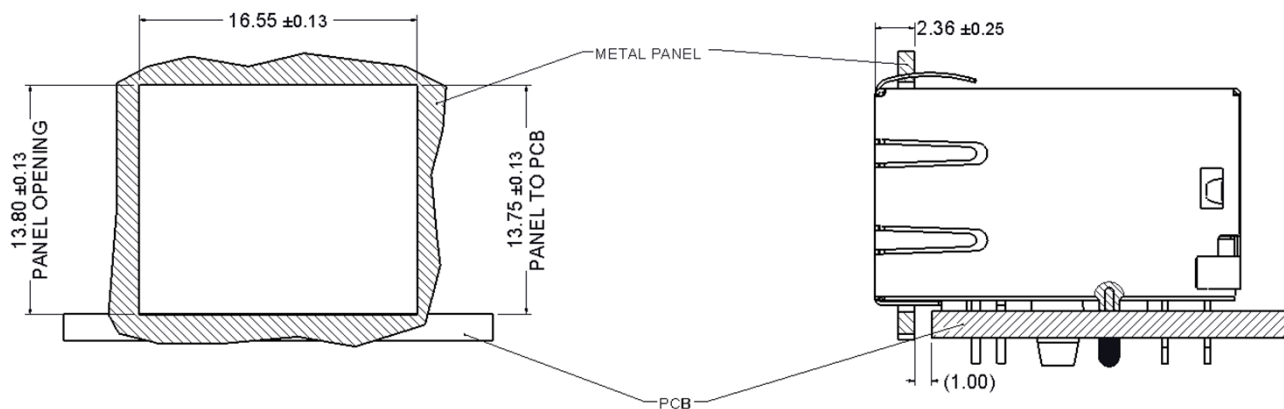

Table1

Layer \ Layout	Trace	component	Grounding	Test Point	Via Hole	PTH	NPTH
Component side	X	X	O	X	X	X	O
Inner layer	O	NA	O	NA	O	X	O
Bottom side	O	O	O	O	O	X	O

X--Forbid; O--OK; NA--Not Applicable.

### 1.3 Recommended panel cutout



## 1.4 Standard RJ45 Plug Specification

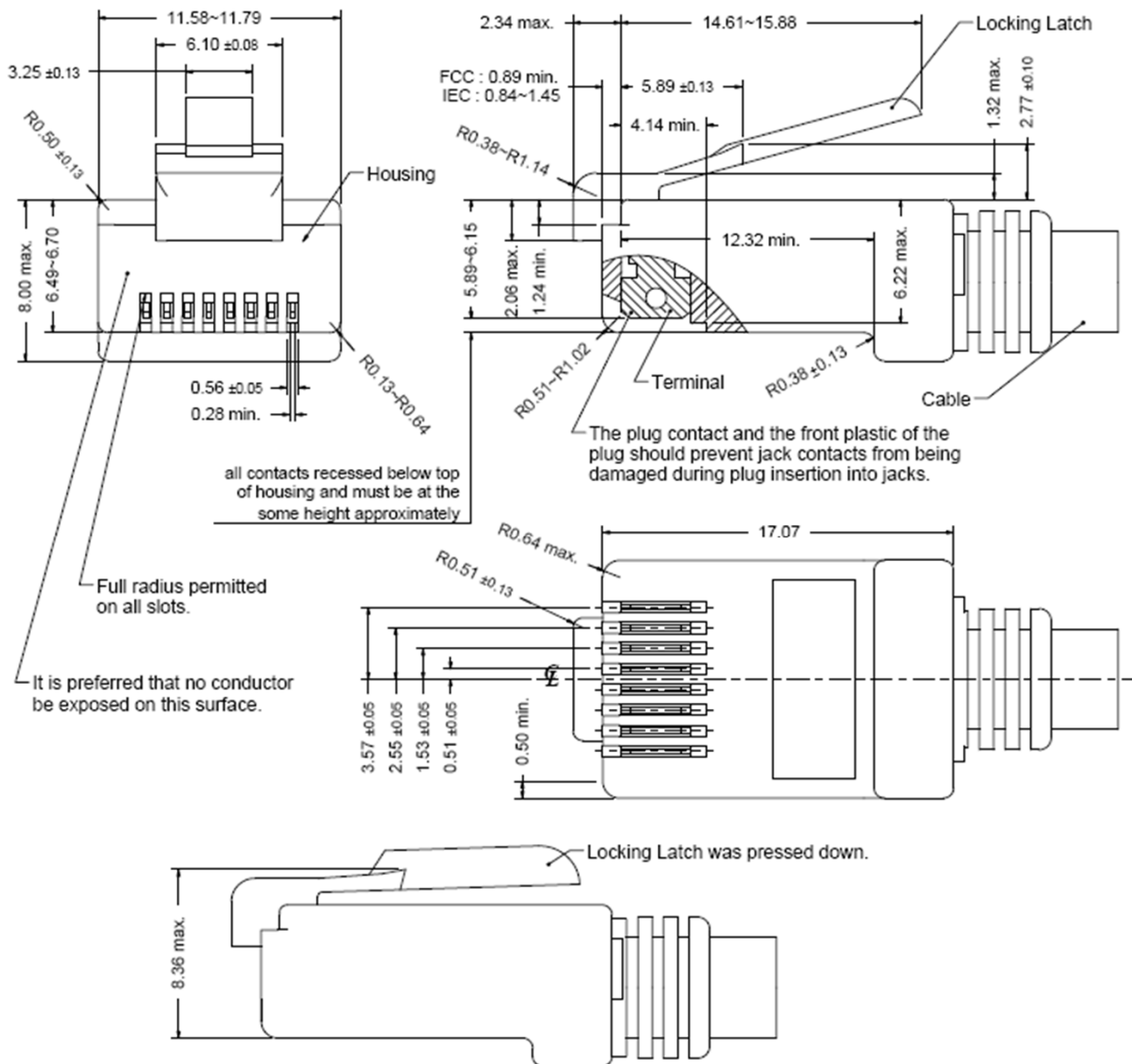

- All dimensions follow :

FCC subpart F, 68,500, Figure (C)(2)(i) & (C)(2)(ii) & (C)(3)(i)

IEC 60603-7

- All plugs must be meeting the requirements of plug Go & No-Go gauge.

Gauge follow : FCC subpart F, 68,500, Figure (C)(4)(i) & (C)(5)(i)

- There must be no damage to Housing and Locking Latch.

- There must be no nicks and cuts in cable.

- Durability : 750 cycles generally

## 2. REQUIREMENTS

### 2.1 Design and Construction

Product shall be of design, construction and physical dimensions specified on applicable.

### 2.2 Material

#### 2.2.1 Terminal Parts (Underplating : 50 $\mu$ " min. Nickel overall)

##### 2.2.1.1 RJ Terminal : PH. Bronze, Thickness=0.30mm

Finish : Contact Area : Gold Flash

##### 2.2.1.2 Input Terminal : Brass, Thickness=0.35mm

Finish : 100 $\mu$ " min. Tin

##### 2.2.1.3 Case Terminal : Brass, Thickness=0.30mm

Finish : 100 $\mu$ " min. Tin

#### 2.2.2 Plastic Parts

##### 2.2.2.1 Housing : PA6T, Black

UL File No: <E52579>

##### 2.2.2.2 Case : PA6T, Black

#### 2.2.3 Shield Parts : Stainless, Thickness=0.20mm, Pre-soldering

#### 2.2.4 PCB Parts : UL File NO: <E221000>

### 2.3 Operating and Storage Temperature

Operating Temperature : 0°C to +70°C

Storage Temperature : -40°C to +85°C

### 2.4 RJ45 specifications

Insulation Resistance : 500MΩ min.

Insertion force with the latch depressed : 20N max

Removal force with the latch depressed : 20N max

Locking Force of Plug Latch : 50N min. @ 60+/-5 sec

Durability : 750 cycles

### 2.5 Performance and Test Description

Product is designed to meet electrical, mechanical and environmental performance requirements specified in below table. All tests are performed at ambient environmental conditions per MIL-STD-1344A and EIA-364 unless otherwise specified.

### 2.6 Packaging and Packing

All parts shall be packaged and packed to protect against physical damage 、 corrosion and deterioration during shipment and storage.

### 3. ELECTRICAL CHARACTERISTICS

#### 3.1 Schematic

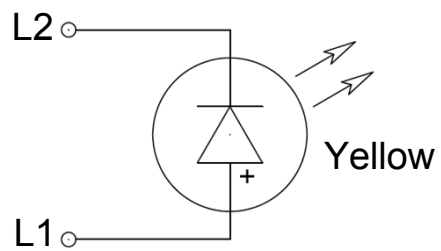
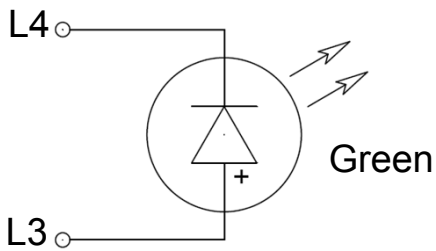
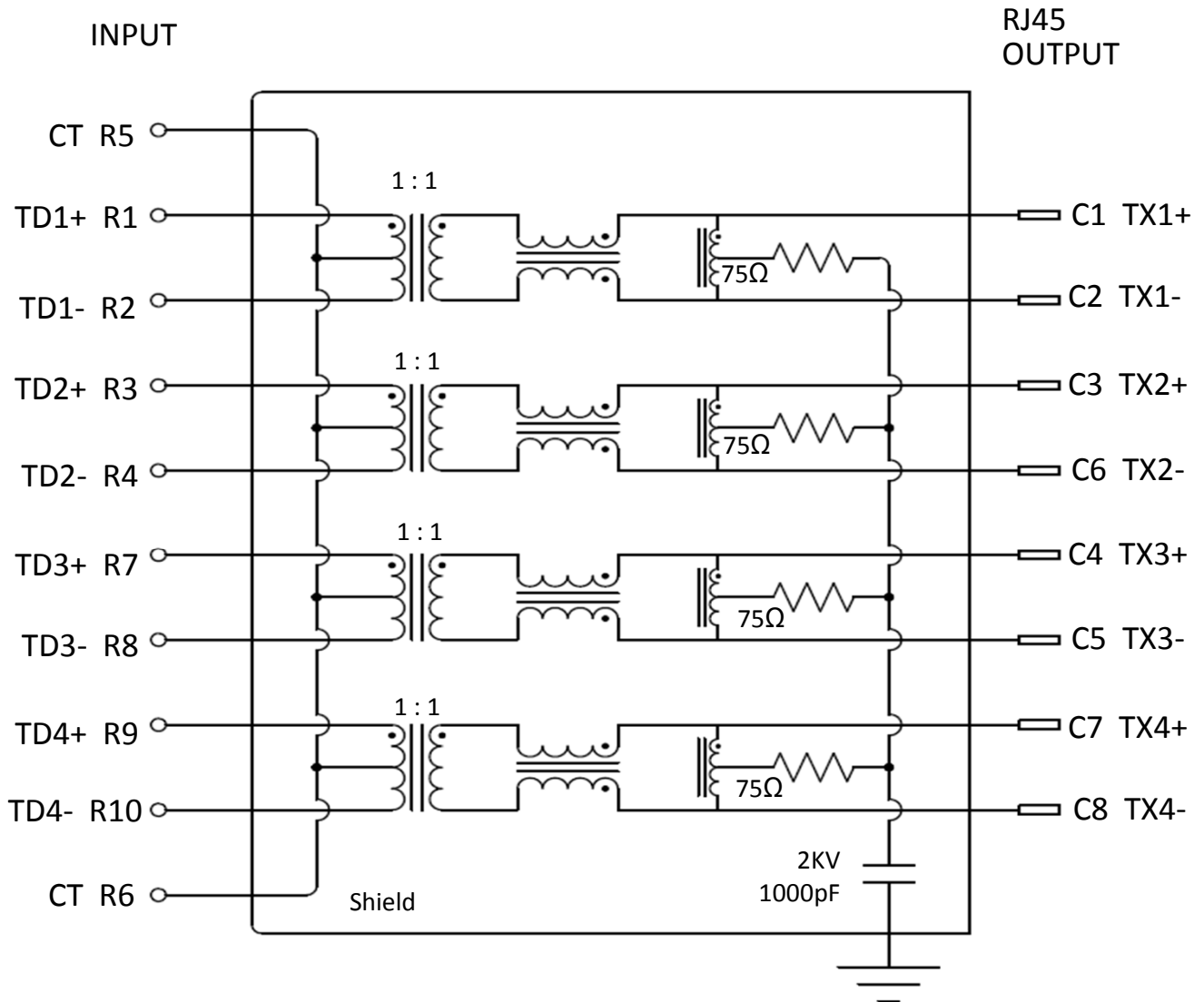

Emitting Color	$\lambda_p$ (nm)	$V_f @ I_f=20mA$	$I_r @ V_r=5V$
Green	570	1.7 ~2.6 V	10 $\mu$ A max.
Yellow	588	1.7 ~2.6 V	10 $\mu$ A max.



### 3.2 Transmitter filter & Receiver filter

Type : Balance low pass 100Ω impedance

Insertion loss : 1~100 MHz -1.0dB max.

Return loss : 1~30 MHz -18dB min. load 100Ω

30~60MHz -16dB min. load 100Ω

60~80MHz -12dB min. load 100Ω

80~100MHz -10dB min. load 100Ω

### 3.3 Common Mode Rejection

@ 1~100 MHz -30dB min.

### 3.4 Cross Talk

@ 1~100 MHz -30dB min.

### 3.5 Inductance @ 100KHz, 0.1V, 8mA DC BIAS

Input(R1-R2), Input(R3-R4), Input(R7-R8), Input(R9-R10) : 350 μH min.

### 3.6 Hi-Pot Test

Input(R1-R2) To Output(C1-C2) : 1500Vac 60s or 2250Vdc 60s

Input(R3-R4) To Output(C3-C6) : 1500Vac 60s or 2250Vdc 60s

Input(R7-R8) To Output(C4-C5) : 1500Vac 60s or 2250Vdc 60s

Input(R9-R10) To Output(C7-C8) : 1500Vac 60s or 2250Vdc 60s

## 4. ORDER INFORMATION

R B 1 - 1 2 5B AK1 A  
 A B C D

## A. LED Code :

L-Green ; R-Yellow. <Refer to Schematic of LED>

## B. Mechanical Code :

w/ UDE Logo, w/ All Spring

## C. Schematics Code :

AK1 : AK1 circuit

## D. Plating Code :

Underplating	50 $\mu$ "min. Nickel overall	
Solder Tail	100 $\mu$ " min. Bright Tin	100 $\mu$ " min. Matted Tin
Contact Area	<u>A : Gold Flash</u> C : 6 $\mu$ " gold B : 10 $\mu$ " gold D : 15 $\mu$ " gold F : 30 $\mu$ " gold G : 50 $\mu$ " gold	1 : Gold Flash 6 : 6 $\mu$ " gold  2 : 15 $\mu$ " gold 3 : 30 $\mu$ " gold 4 : 50 $\mu$ " gold

## 5. WAVE SOLDERING TEMPERATURE PROFILE

## Note :

The measuring point for the specified temperature shall be on the soldered part of the lead.

