

FEATURES

- ◆ 350 Watts Peak Pulse Power ($t_p=8/20\mu s$)
- ◆ Replacement for SOD323
- ◆ Protects two I/O and one power line
- ◆ Low Clamping Voltage
- ◆ Reverse Voltage: 5 V
- ◆ Low Leakage Current
- ◆ Response Time is Typically < 1 ns

IEC COMPATIBILITY (EN61000-4)

- ◆ IEC 61000-4-2 ESD air ± 15 KV , contact ± 8 KV
- ◆ IEC 61000-4-4 ETF 20A (5/50ns)
- ◆ IEC 61000-4-5 Surge 17A (8/20 μs)

Mechanical Characteristics

- ◆ JEDEC SOD323 package
- ◆ RoHS Compliant

Applications

- ◆ Cellular Handsets and Accessories
- ◆ Portable Electronics
- ◆ Industrial Controls
- ◆ Set-Top Box
- ◆ Servers, Notebook, and Desktop PC

Schematic & PIN Configuration

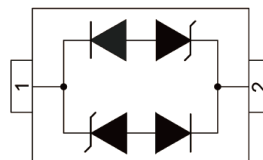

SOD323 Top View

ABSOLUTE MAXIMUM RATING

Rating	Symbol	Value	Units
Peak Pulse Power ($t_p = 8/20\mu s$)	P_{PK}	350	Watts
Lead Soldering Temperature	T_L	260 (10sec)	°C/W
Operating Temperature	T_J	-55~150	°C
Storage Temperature	T_{STG}	-40~120	°C
IEC61000-4-2	V_{PP}	Air 15 Contact 8	KV

ELECTRICAL CHARACTERISTICS

GBLC03C

Parameter	Symbol	Conditions	Min	Typical	Max	Units
Reverse Stand-Off Voltage	V_{RWM}				3.3	V
Reverse Breakdown Voltage	V_{BR}	$I_t=1mA$	4			V
Leakage Current	I_R	@ V_{RWM}			5	μA
Clamping Voltage	V_C	@1A			7	V
Clamping Voltage	V_C	@19A			19	V
Junction Capacitance	C_J	$V_R=0V, f=1Mhz$		0.8		pf

GBLC05C

Parameter	Symbol	Conditions	Min	Typical	Max	Units
Reverse Stand-Off Voltage	V_{RWM}				5	V
Reverse Breakdown Voltage	V_{BR}	$I_t=1mA$	6			V
Leakage Current	I_R	@ V_{RWM}			5	μA
Clamping Voltage	V_C	@1A			9.8	V
Clamping Voltage	V_C	@17A			18.3	V
Junction Capacitance	C_J	$V_R=0V, f=1Mhz$		0.8		pf

ELECTRICAL CHARACTERISTICS

GBLC08C

Parameter	Symbol	Conditions	Min	Typical	Max	Units
Reverse Stand-Off Voltage	V_{RWM}				8.0	V
Reverse Breakdown Voltage	V_{BR}	$I_t=1mA$	8.5			V
Leakage Current	I_R	@ V_{RWM}			2	μA
Clamping Voltage	V_C	@1A			13.4	V
Clamping Voltage	V_C	@17A			18.5	V
Junction Capacitance	C_J	$V_R=0V, f=1Mhz$		0.8		pf

GBLC12C

Parameter	Symbol	Conditions	Min	Typical	Max	Units
Reverse Stand-Off Voltage	V_{RWM}				12	V
Reverse Breakdown Voltage	V_{BR}	$I_t=1mA$	13.3			V
Leakage Current	I_R	@ V_{RWM}			1	μA
Clamping Voltage	V_C	@1A			19	V
Clamping Voltage	V_C	@11A			28.6	V
Junction Capacitance	C_J	$V_R=0V, f=1Mhz$		0.8		pf

GBLC24C

Parameter	Symbol	Conditions	Min	Typical	Max	Units
Reverse Stand-Off Voltage	V_{RWM}				24	V
Reverse Breakdown Voltage	V_{BR}	$I_t=1mA$	26.7			V
Leakage Current	I_R	@ V_{RWM}			1	μA
Clamping Voltage	V_C	@1A			43	V
Clamping Voltage	V_C	@10A			31.8	V
Junction Capacitance	C_J	$V_R=0V, f=1Mhz$		0.8		pf

Figure 1: Peak Pulse Power vs. Pulse Time

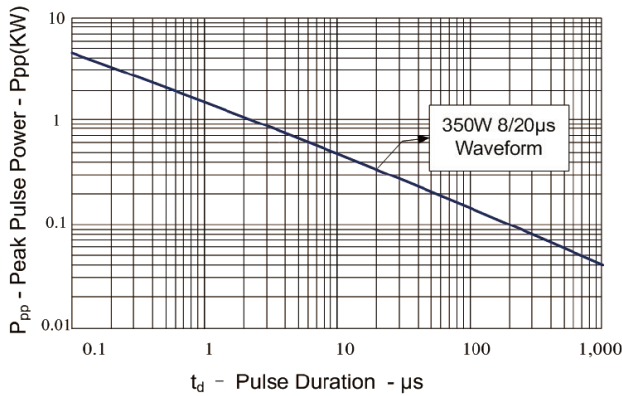

Figure 2: Power Derating Curve

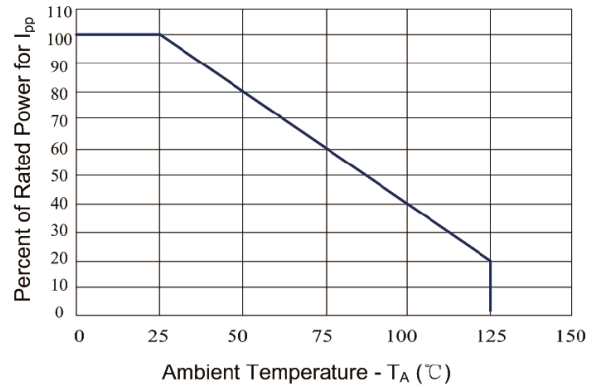

Figure 3: Clamping Voltage vs. Peak Pulse Current

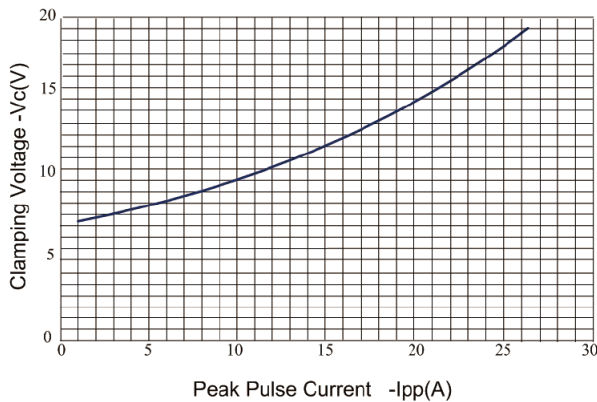

Figure 4: Normalized Junction Capacitance vs. Reverse Voltage

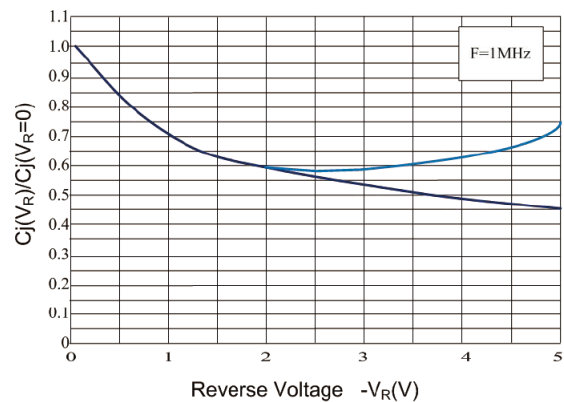

Figure 5: Pulse Waveform

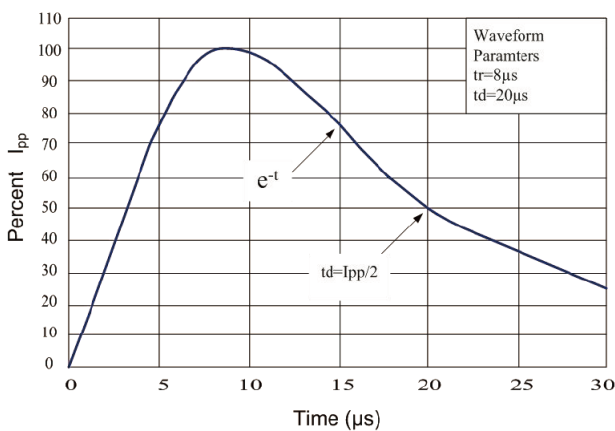
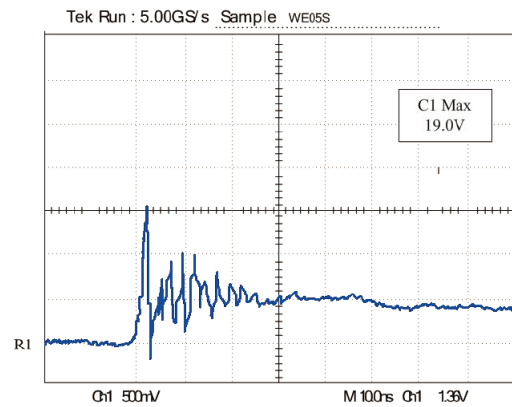



Figure 6: ESD Clamping(8kV Contact per IEC 61000-4-2)



Marking

Type number	Marking code	Example
GBLC03C	CA1	
GBLC05C	5B/AC	
GBLC08C	8B/BC	
GBLC12C	AB	
GBLC24C	CB/HC	

OUTLINE DRAWING - SOD323

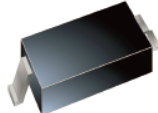
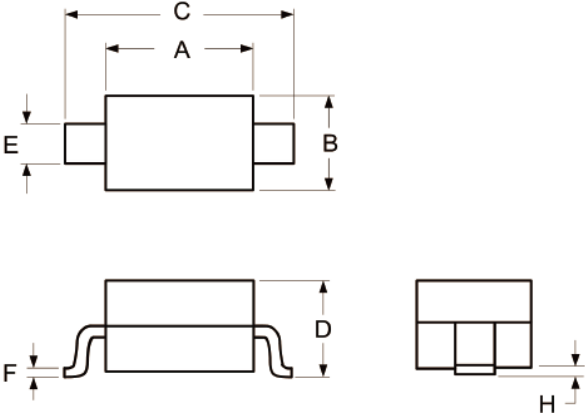
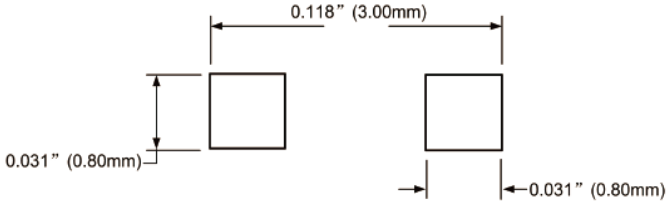
PACKAGE OUTLINE		 SOD-323																																													
		DIMENSIONS <table border="1"> <thead> <tr> <th rowspan="2">SYMBOL</th> <th colspan="2">MILLIMETER</th> <th colspan="2">INCHES</th> </tr> <tr> <th>MIN</th> <th>MAX</th> <th>MIN</th> <th>MAX</th> </tr> </thead> <tbody> <tr> <td>A</td> <td>1.60</td> <td>1.90</td> <td>0.063</td> <td>0.075</td> </tr> <tr> <td>B</td> <td>1.15</td> <td>1.45</td> <td>0.045</td> <td>0.057</td> </tr> <tr> <td>C</td> <td>2.39</td> <td>2.70</td> <td>0.094</td> <td>0.106</td> </tr> <tr> <td>D</td> <td>0.92</td> <td>1.10</td> <td>0.036</td> <td>0.043</td> </tr> <tr> <td>E</td> <td>0.25</td> <td>0.40</td> <td>0.010</td> <td>0.016</td> </tr> <tr> <td>F</td> <td>0.10</td> <td>0.20</td> <td>0.004</td> <td>0.008</td> </tr> <tr> <td>H</td> <td>-</td> <td>0.10</td> <td>-</td> <td>0.004</td> </tr> </tbody> </table>		SYMBOL	MILLIMETER		INCHES		MIN	MAX	MIN	MAX	A	1.60	1.90	0.063	0.075	B	1.15	1.45	0.045	0.057	C	2.39	2.70	0.094	0.106	D	0.92	1.10	0.036	0.043	E	0.25	0.40	0.010	0.016	F	0.10	0.20	0.004	0.008	H	-	0.10	-	0.004
SYMBOL	MILLIMETER		INCHES																																												
	MIN	MAX	MIN	MAX																																											
A	1.60	1.90	0.063	0.075																																											
B	1.15	1.45	0.045	0.057																																											
C	2.39	2.70	0.094	0.106																																											
D	0.92	1.10	0.036	0.043																																											
E	0.25	0.40	0.010	0.016																																											
F	0.10	0.20	0.004	0.008																																											
H	-	0.10	-	0.004																																											
MOUNTING PAD 		Notes <ol style="list-style-type: none"> Controlling Dimensions in Millimeters. Dimensions are exclusive of mold flash and metal burrs. TAPE & REEL ORDERING NOMENCLATURE <ol style="list-style-type: none"> Surface mount product is taped and reeled in accordance with EIA-481. 																																													