

Description
The G30N20 uses advanced trench technology and design to provide excellent $R_{DS(ON)}$ with low gate charge. It can be used in a wide variety of applications.

General Features

- High density cell design for ultra low $R_{DS(on)}$
- Fully characterized avalanche voltage and current
- Good stability and uniformity with high E_{AS}
- Excellent package for good heat dissipation
- Special process technology for high ESD capability
- RoHS Compliant

Application

- Power switching application
- Hard switched and high frequency circuits
- Uninterruptible power supply

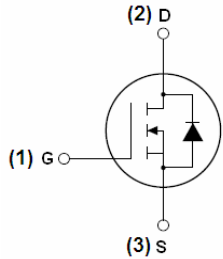

Schematic diagram



Marking and Pin Assignment

Ordering Information

Part Number	Marking	Case	Packaging
G30N20K	G30N20	TO-252	2500pcs/Reel
G30N20T	G30N20	TO-220	50pcs/Tube
G30N20F	G30N20	TO-220F	50pcs/Tube

Absolute Maximum Ratings ($T_C=25^{\circ}C$ unless otherwise noted)

Symbol	Parameter	Max.			Units	
		TO-220	TO-220F	TO-252		
V_{DSS}	Drain-Source Voltage	200			V	
V_{GSS}	Gate-Source Voltage	± 20			V	
I_D	Continuous Drain Current	$T_C = 25^{\circ}C$	30	30	30	A
		$T_C = 100^{\circ}C$	21	21	21	A
I_{DM}	Pulsed Drain Current	100	100	100	A	
E_{AS}	Single Pulsed Avalanche Energy ^(Note5)	250			mJ	
P_D	Power Dissipation	220	60	150	W	
$R_{\theta JC}$	Thermal Resistance, Junction to Case	0.68	2.5	1	$^{\circ}C/W$	
T_J, T_{STG}	Operating and Storage Temperature Range	-55 to +150			$^{\circ}C$	

Electrical Characteristics (T_C=25°C unless otherwise noted)

Parameter	Symbol	Condition	Min	Typ	Max	Unit
Off Characteristics						
Drain-Source Breakdown Voltage	BV _{DSS}	V _{GS} =0V I _D =250μA	200	220	-	V
Zero Gate Voltage Drain Current	I _{DSS}	V _{DS} =200V, V _{GS} =0V	-	-	1	μA
Gate-Body Leakage Current	I _{GSS}	V _{GS} =±20V, V _{DS} =0V	-	-	±100	nA
On Characteristics (Note 3)						
Gate Threshold Voltage	V _{GS(th)}	V _{DS} =V _{GS} , I _D =250μA	2.5	3.2	4.5	V
Drain-Source On-State Resistance	R _{DS(ON)}	V _{GS} =10V, I _D =15A	-	62	80	mΩ
Forward Transconductance	g _{FS}	V _{DS} =10V, I _D =15A	30	-	-	S
Dynamic Characteristics (Note4)						
Input Capacitance	C _{iss}	V _{DS} =25V, V _{GS} =0V, F=1.0MHz	-	4200	-	PF
Output Capacitance	C _{oss}		-	163	-	PF
Reverse Transfer Capacitance	C _{rss}		-	75	-	PF
Switching Characteristics (Note 4)						
Turn-on Delay Time	t _{d(on)}	V _{DD} =100V, I _D =15A V _{GS} =10V, R _{GEN} =2.5Ω	-	10	-	nS
Turn-on Rise Time	t _r		-	18	-	nS
Turn-Off Delay Time	t _{d(off)}		-	22	-	nS
Turn-Off Fall Time	t _f		-	5	-	nS
Total Gate Charge	Q _g	V _{DS} =100V, I _D =15A, V _{GS} =10V	-	60	-	nC
Gate-Source Charge	Q _{gs}		-	19	-	nC
Gate-Drain Charge	Q _{gd}		-	17	-	nC
Drain-Source Diode Characteristics						
Diode Forward Voltage (Note 3)	V _{SD}	V _{GS} =0V, I _S =15A	-	-	1.2	V
Diode Forward Current (Note 2)	I _S	-	-	-	30	A
Reverse Recovery Time	t _{rr}	T _J = 25°C, I _F = 15A	-	90	-	nS
Reverse Recovery Charge	Q _{rr}	di/dt = 100A/μs (Note3)	-	300	-	nC

Notes:

1. Repetitive Rating: Pulse width limited by maximum junction temperature.
2. Surface Mounted on FR4 Board, t ≤ 10 sec.
3. Pulse Test: Pulse Width ≤ 300μs, Duty Cycle ≤ 2%.
4. Guaranteed by design, not subject to production
5. EAS condition: T_j=25°C, V_{DD}=50V, V_G=10V, L=0.5mH, R_g=25Ω

Test Circuit

1) E_{AS} Test Circuits

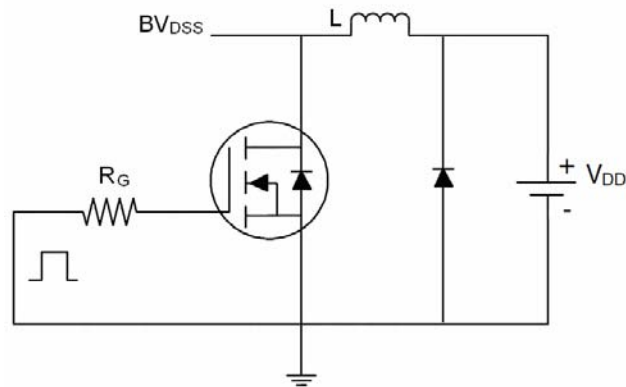

2) Gate Charge Test Circuit



3) Switch Time Test Circuit

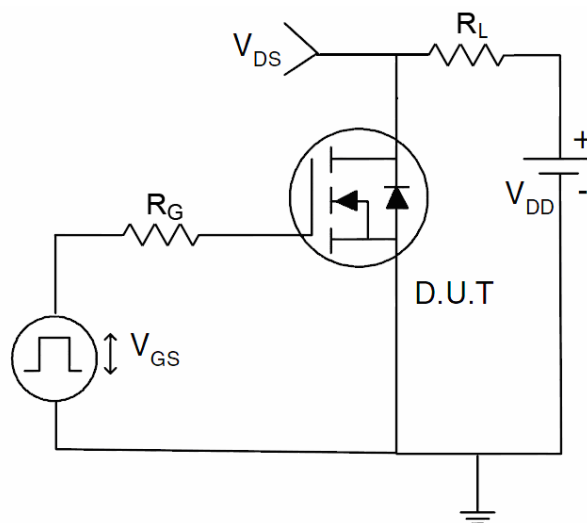

Typical Electrical and Thermal Characteristics (Curves)

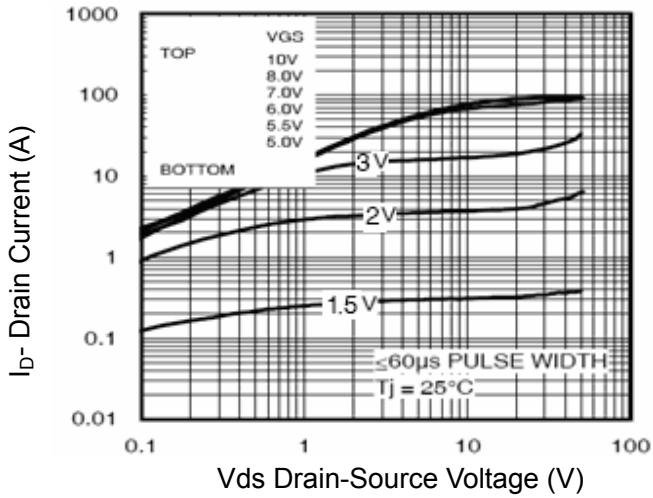

Figure 1 Output Characteristics

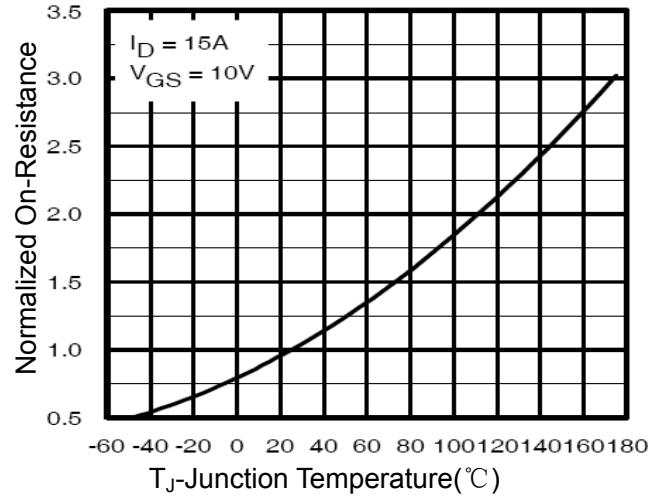

Figure 4 R_{dson} -Junction Temperature

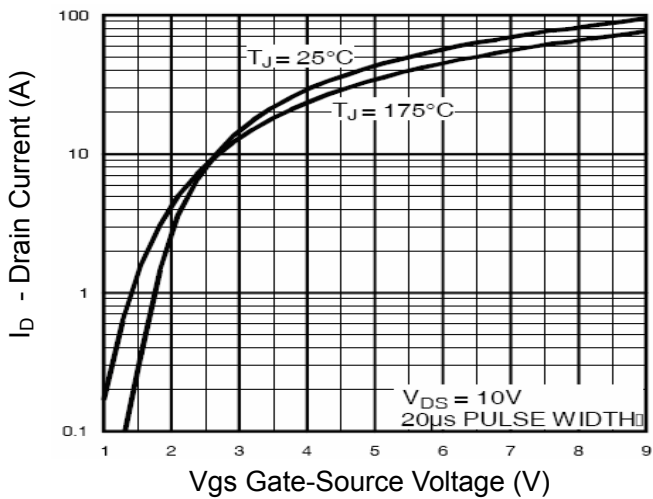

Figure 2 Transfer Characteristics

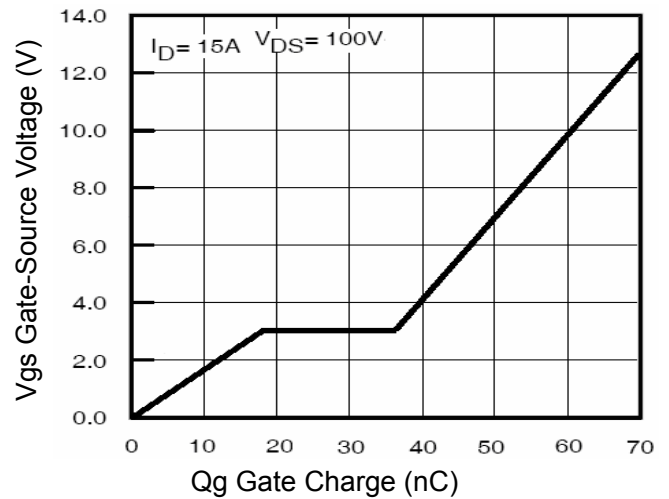

Figure 5 Gate Charge

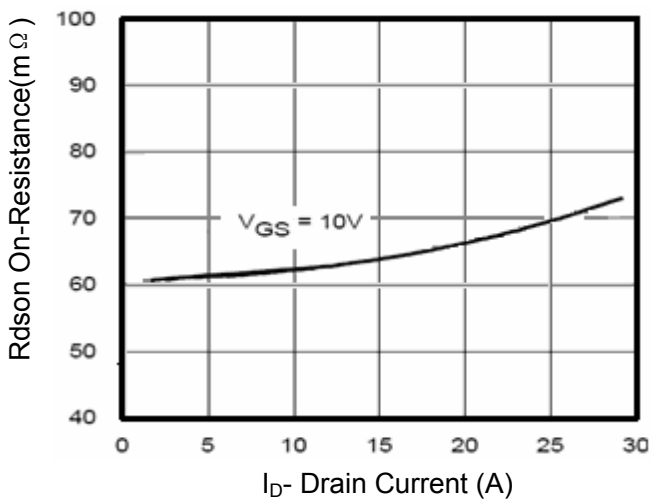

Figure 3 R_{dson} - Drain Current

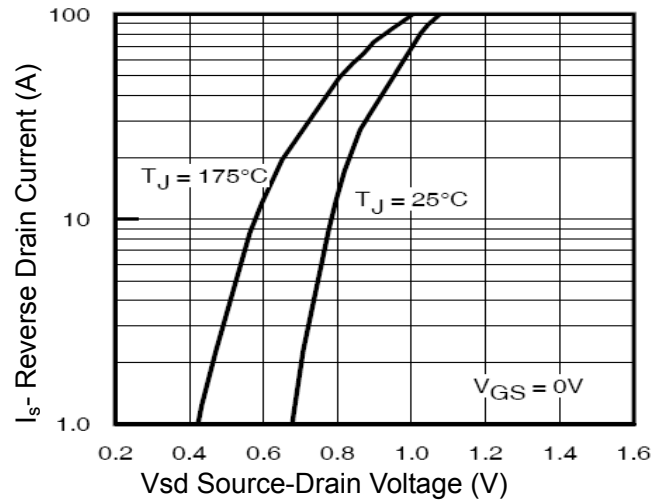

Figure 6 Source- Drain Diode Forward

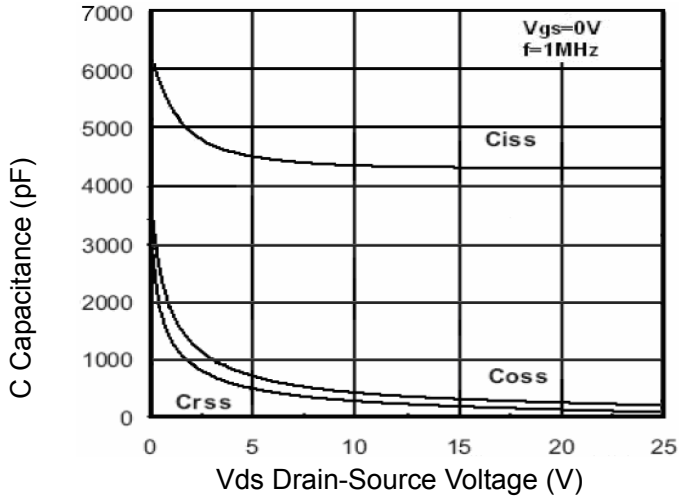

Figure 7 Capacitance vs Vds

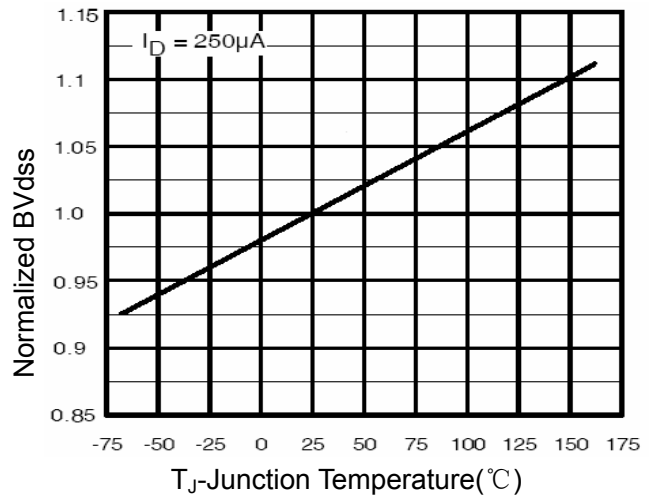

Figure 9 BV_{DSS} vs Junction Temperature

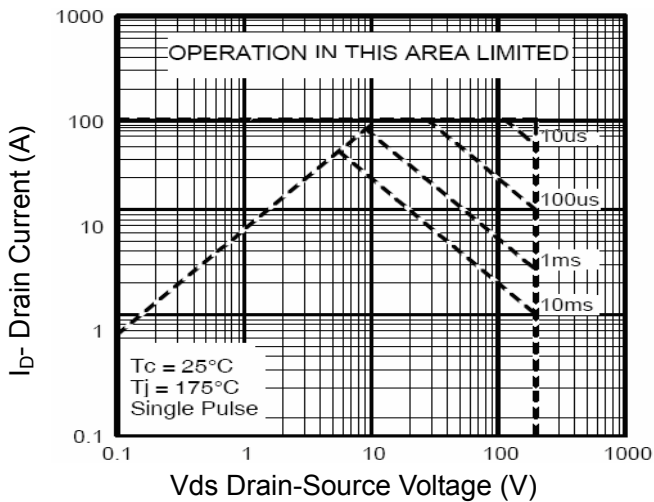

Figure 8 Safe Operation Area

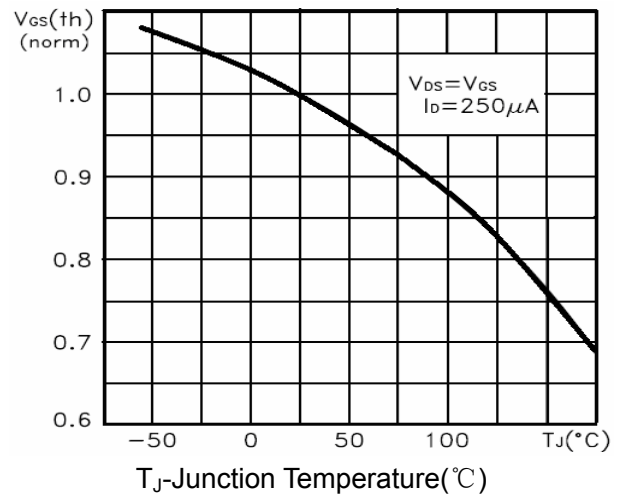

Figure 10 $V_{GS(th)}$ vs Junction Temperature

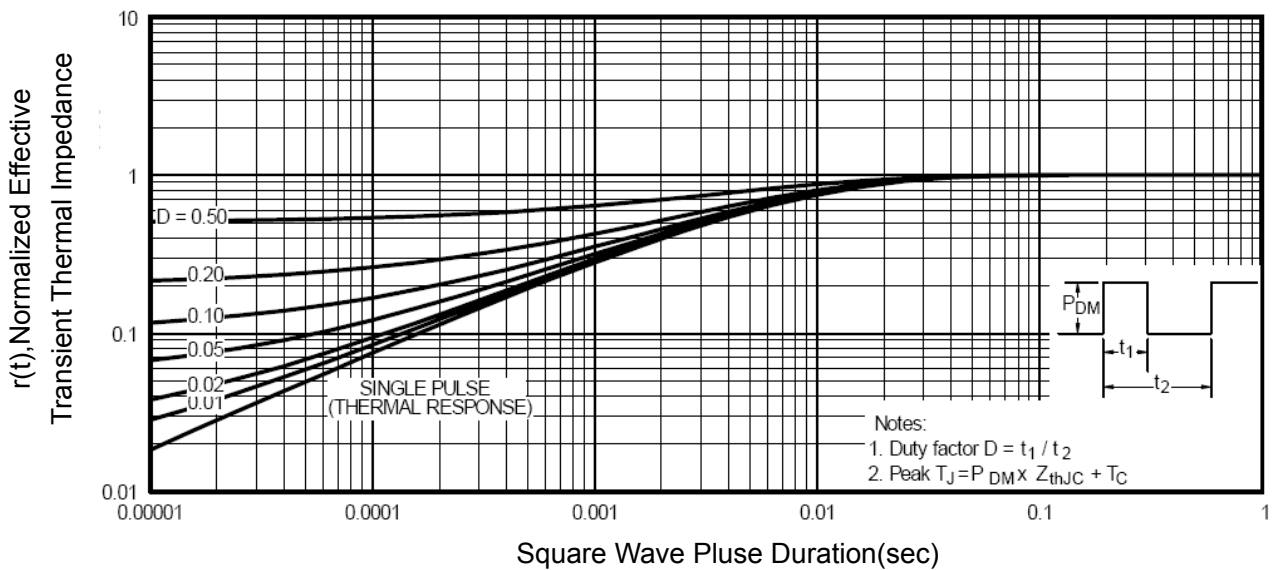
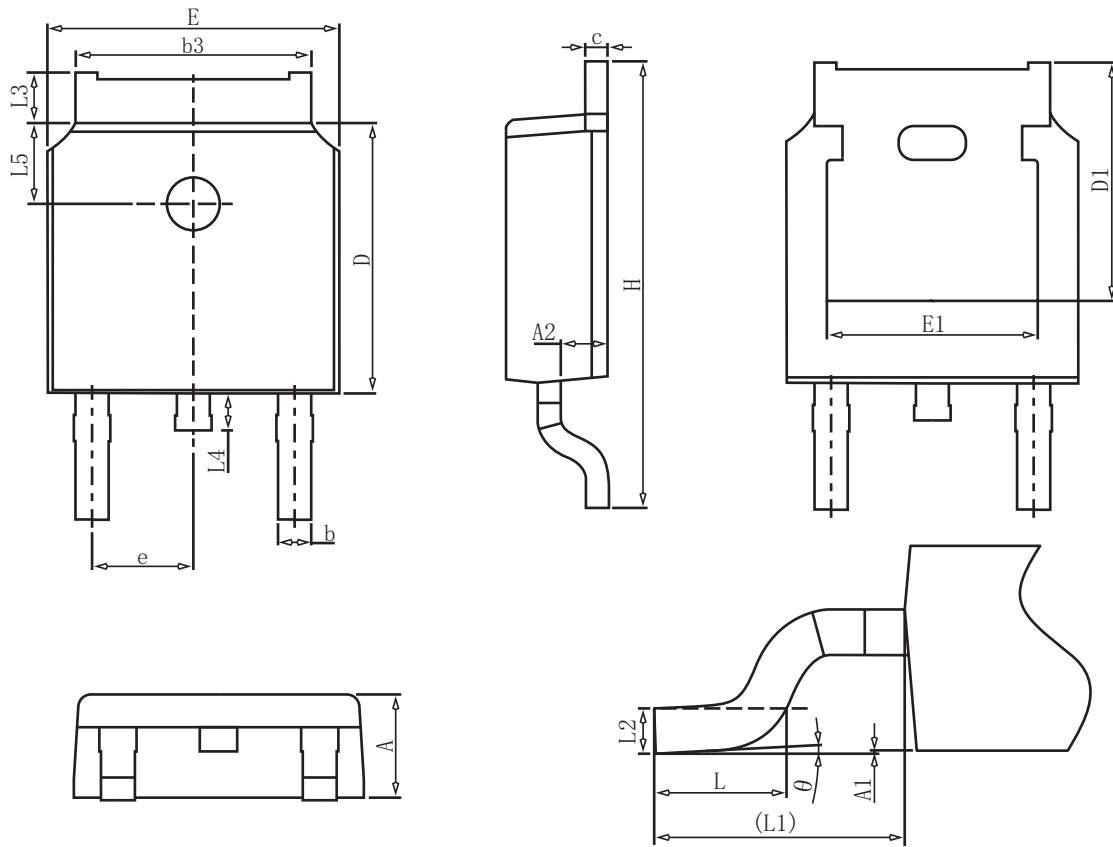

Figure 11 Normalized Maximum Transient Thermal Impedance

TO-252 Package information



COMMON DIMENSIONS

SYMBOL	mm		
	MIN	NOM	MAX
A	2.20	2.30	2.40
A1	0.00	-	0.20
A2	0.97	1.07	1.17
b	0.68	0.78	0.90
b3	5.20	5.33	5.50
c	0.43	0.53	0.63
D	5.98	6.10	6.22
D1	5.30REF		
E	6.40	6.60	6.80
E1	4.63	-	-
e	2.286BSC		
H	9.40	10.10	10.50
L	1.38	1.50	1.75
L1	2.90REF		
L2	0.51BSC		
L3	0.88	-	1.28
L4	0.50	-	1.00
L5	1.65	1.80	1.95
θ	0°	-	8°

TO-220 Package information

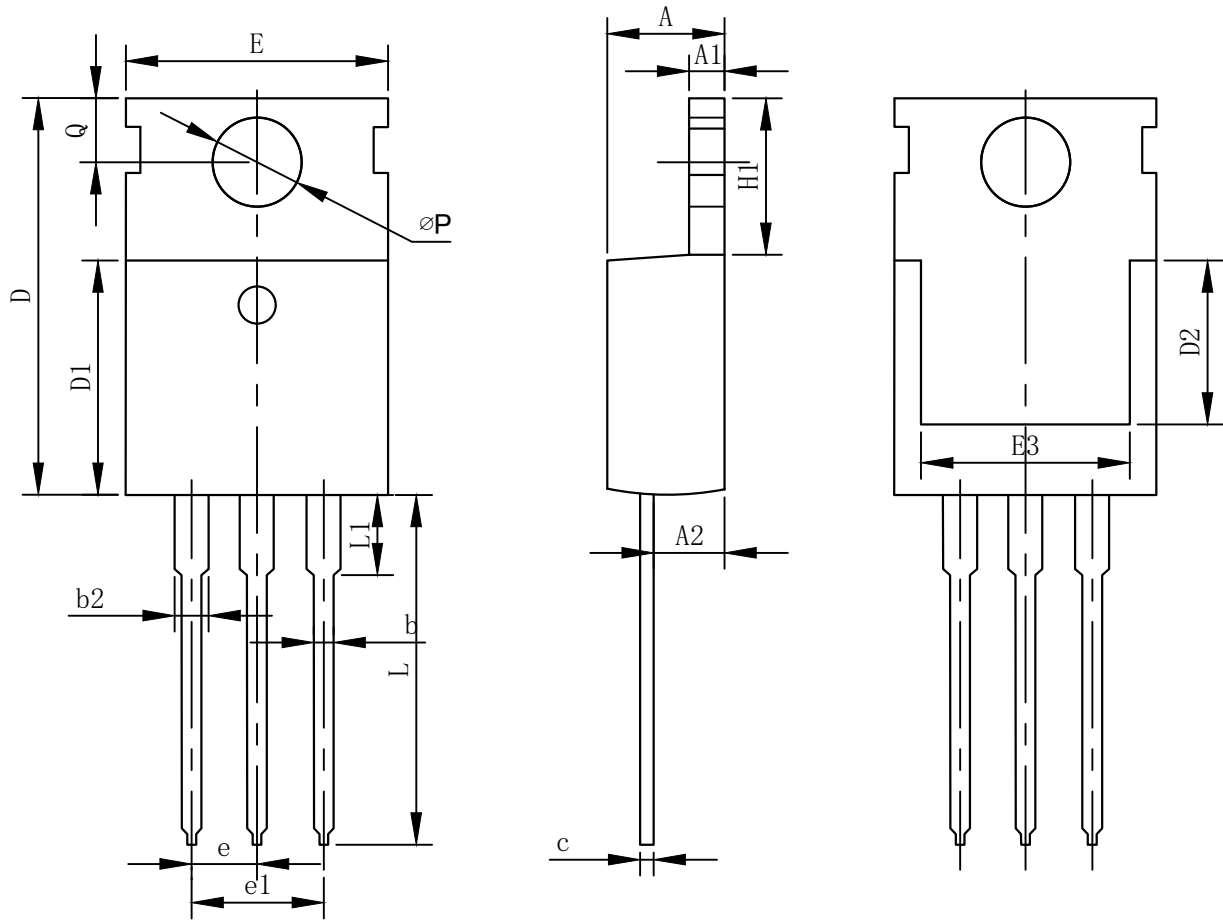

COMMON DIMENSIONS

SYMBOL	mm		
	MIN	NOM	MAX
A	4.37	4.57	4.70
A1	1.25	1.30	1.40
A2	2.20	2.40	2.60
b	0.70	0.80	0.95
b2	1.70	1.27	1.47
c	0.45	0.50	0.60
D	15.10	15.60	16.10
D1	8.80	9.10	9.40
D2	5.50	-	-
E	9.70	10.00	10.30
E3	7.00	-	-
e	2.54BSC		
e1	5.08BSC		
H1	6.25	6.50	6.85
L	12.75	13.50	13.80
L1	-	3.10	3.40
ϕP	3.40	3.60	3.80
Q	2.60	2.80	3.00

TO-220F Package information

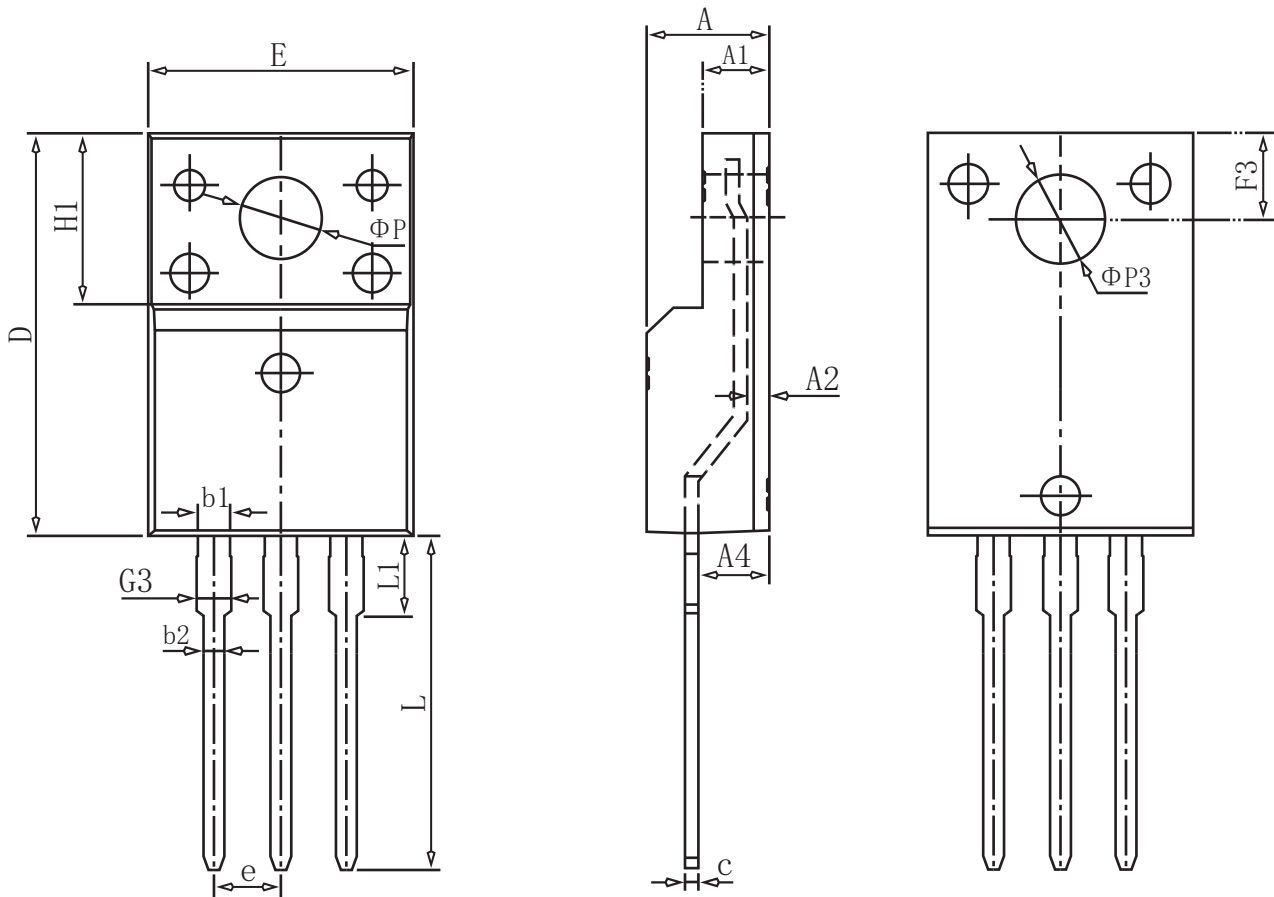

COMMON DIMENSIONS

SYMBOL	mm		
	MIN	NOM	MAX
E	10.00	10.20	10.40
A	4.50	4.70	4.90
A1	2.34	2.54	2.74
A2	0.65	0.85	1.30
A4	2.55	2.75	2.95
c	0.40	0.50	0.65
D	15.57	15.87	16.17
H1	6.70REF		
e	2.54BSC		
ΦP	3.183REF		
L	12.68	12.98	13.28
L1	3.25	3.45	3.65
$\Phi P3$	3.45REF		
F3	3.10	3.30	3.50
G3	1.10	1.30	1.50
b1	1.05	1.20	1.35
b2	0.70	0.80	0.92