

RFIC Preliminary 2016.06 Rev1.0

DESCRIPTION

The SW373C is a SOI CMOS MMIC SP3T switch. The high power performance and low insertion loss makes the device ideally suitable for handset and data card applications, as well as any other general purpose usage for Tx/Rx selection or antenna diversity function operating up to 6GHz. The SW373C is housed in a miniature 2mmx2mm, 12-pin, QFN leadless (Pb free) package. An internal negative voltage generator and decoder are included in the design and no external DC blocking capacitors on the RF ports are needed.

KEY FEATURES

- **Low Insertion:**
0.6dB @ 2.5GHz
- **High Isolation:**
25dB @ 0.1~ 3GHz
- **Low Harmonics > 75dBc @ 35dBm**
- **1.8V control voltage**
- **Wide supply range from 2.5V to 4V**
- **ESD Protection at all ports**

Block Diagram

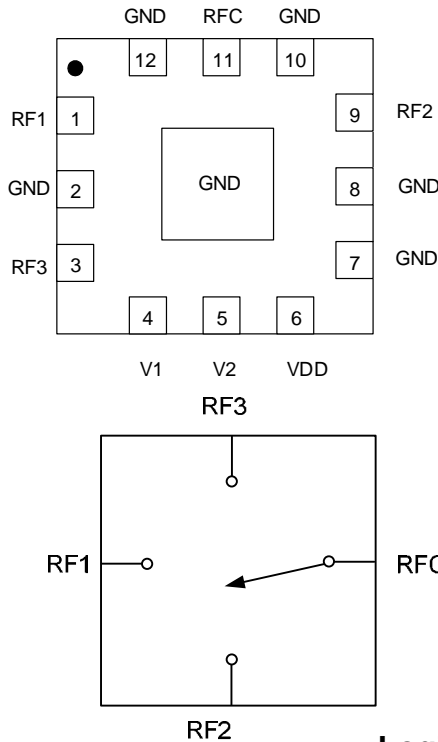

Pin Definition and Function

Pin No.	Name	Description
1	RF1	RF port 1
2	GND	Ground
3	RF3	RF port 3
4	V1	Control voltage 1
5	V2	Control voltage 2
6	VDD	Power Supply
7	GND	Ground
8	GND	Ground
9	RF2	RF port 2
10	GND	Ground
11	RFC	Antenna port
12	GND	Ground

Logic Control Table

High=1.6V to 3.0V
Low= 0V to 0.4V

V1	V2	VDD	State
Low	High	2.5-5V	RF1-ANT
High	Low	2.5-5V	RF2-ANT
High	High	2.5-5V	RF3-ANT
Low	Low	2.5-5V	Shut down

For more information, please contact us at:

Sales Dept.

Tel: +886-2-2698-1022

e-mail: sales@rfintc.com

© 2006 RFIC Technology Corporation All rights reserved.

RFIC Technology Corp. reserved the right to make any changes to the specifications without notice.

RFIC Preliminary 2016.06 Rev1.0

Absolute Maximum Ratings

Parameter	Rating	Unit
Operating Voltage	+5	V
RF Input Power (under acceptable bias state, > 500MHz)	+37	dBm
Operating Ambient Temperature	-40 to +85	°C
Storage Temperature	-40 to +125	°C
ESD _{HBM}	1000 V	

Important Note:

The information provided in this datasheet is deemed to be accurate and reliable only at present time. RFIC Technology Corp. reserves the right to make any changes to the specifications in this datasheet without prior notice.



Caution: ESD Sensitive
Appropriate precaution in handling, packaging
And testing devices must be observed.

Evaluation Board Schematic

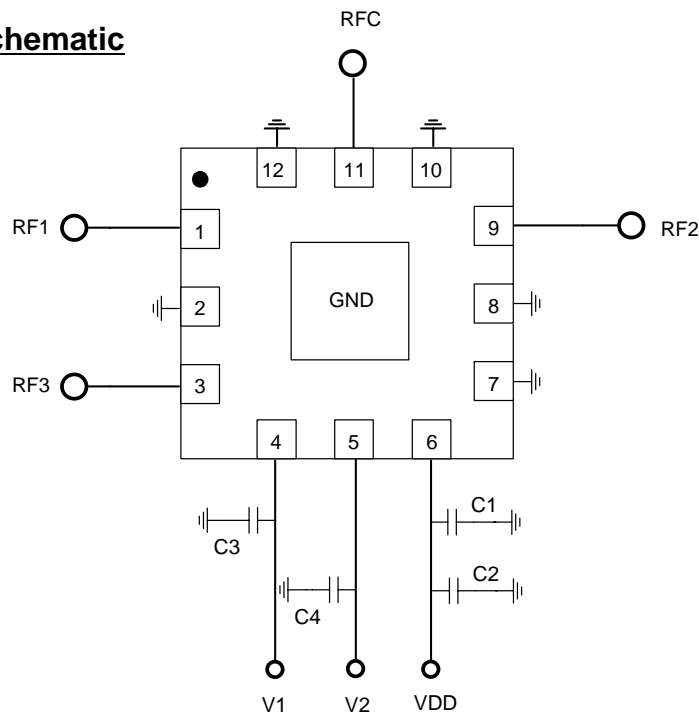

Component	Size	Value	Note
C1	0402	1000pF	Optional
C2	0805	10nF	Optional
C3	0402	1000pF	Optional
C4	0402	1000pF	Optional

Electrical Characteristics for 25 Ambit Temperature

Logic High = 1.8V; Logic Low = 0V; VDD=3V; TA = 25°C; unless otherwise noted

Parameter	Specification			Units	Notes
	Min	Typ.	Max		
Insertion Loss (IL)		0.4 0.5 0.6 0.8	0.5 0.6 0.7 1.5	dB	0.5 – 1.0GHz 1.0 – 2.0GHz 2.0 – 3.0GHz 3.0 – 6.0GHz
Isolation (ISO)	35 30 25 19	40 35 30 25		dB	0.5 – 1.0GHz 1.0 – 2.0GHz 2.0 – 3.0GHz 3.0 – 6.0GHz
Return Loss	10	20		dB	0.5 – 6.0GHz
IP0.1dB		36.5		dBm	0.8-6.0GHz
IIP3		66		dBm	0.8-3GHz, F = 1 MHz, PIN = +20 dBm/tone
2fo	70	75 20		dBc	900MHz, P _{in} =30dBm 900MHz, P _{in} =20dBm
3fo	65	70 86		dBc	900MHz, P _{in} =30dBm 900MHz, P _{in} =20dBm
IMD3		108		dBm	F _{cw1} =1.85GHz, P _{cw1} = +20dBm F _{cw2} =1.74GHz, P _{cw2} = -15dBm
Switching Speed T _{RISE} /T _{FALL} T _{ON} /T _{OFF}		0.25 0.5		us us	10% to 90% RF and 90% to 10% RF 50% control to 90% RF and 50% control to 10% RF
Startup time		15		us	Shutdown state to any RF switch state
Supply Current (I _{cc})		80		uA	VDD=3.0V
Control Current		0.5		uA	V1=V2=1.8V
Shut down mode supply current		5		uA	VDD=3.0V, V1=V2=0V

Note: All measurements made in a 50 ohm system.
Board loss de-embedded

Package Outline

Top View

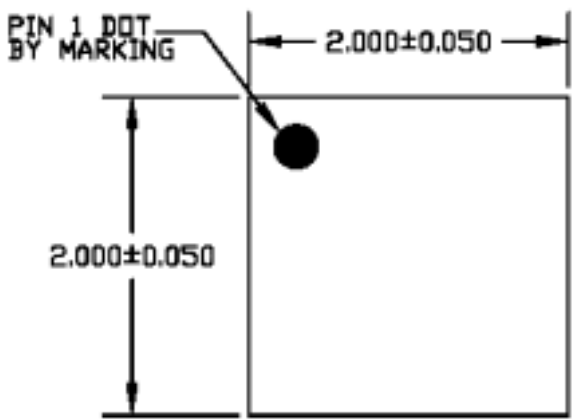

Side View

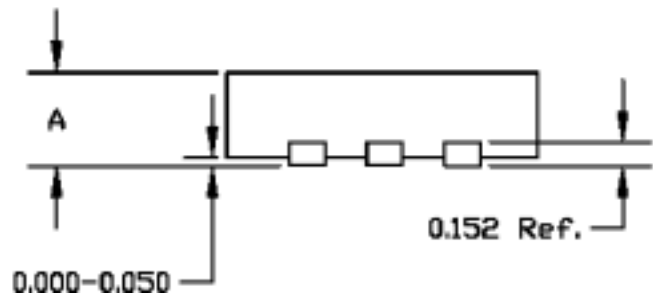

		STSLP
A	MAX.	0.600
	NDM.	0.550
	MIN.	0.500

Bottom View

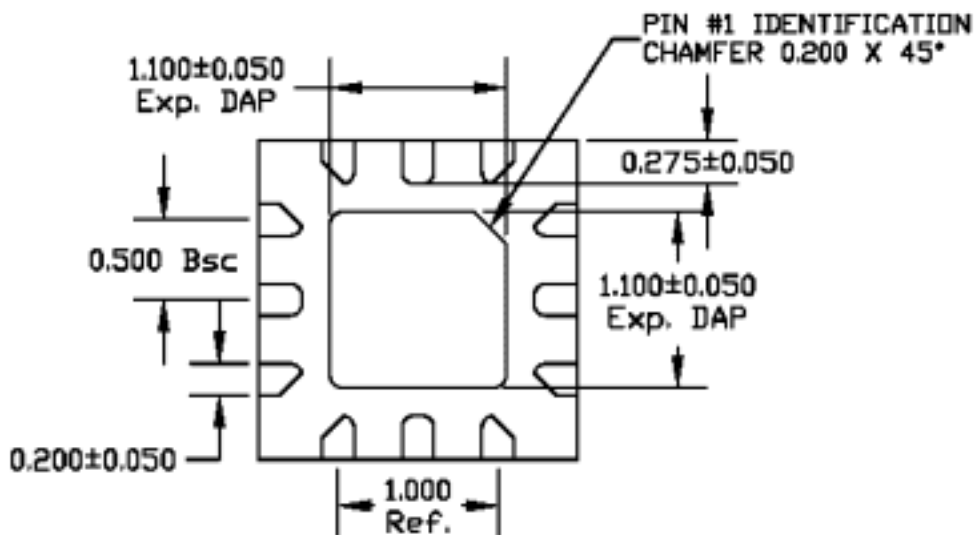

SW373C

Tape Dimension

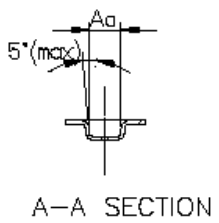
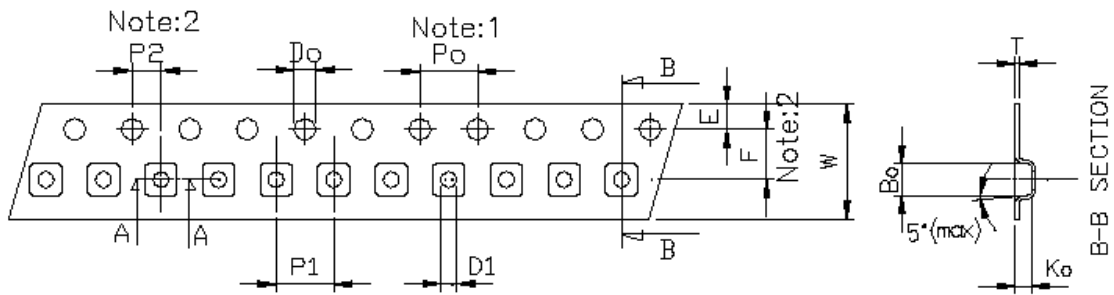

$$A_o = \frac{2.25 \pm 0.10}{\quad} \text{ mm}$$

$$B_o = \frac{2.25 \pm 0.10}{\quad} \text{ mm}$$

$$K_o = \frac{1.15 \pm 0.10}{\quad} \text{ mm}$$

Unit: mm

Symbol	Spec.
K1	-
Po	4.0±0.10
P1	4.0±0.10
P2	2.0±0.05
Do	1.50 ^{+0.10} ₊₀
D1	1.10±0.10
E	1.75±0.10
F	3.50±0.05
10Po	40.0±0.10
W	8.0±0.20
T	0.25±0.02

Notice:

1. 10 Sprocket hole pitch cumulative tolerance is ±0.1mm
2. Pocket position relative to sprocket hole measured as true position of pocket not pocket hole.
3. Ao & Bo measured on a plane 0.3mm above the bottom of the pocket to top surface of the carrier.
4. Ko measured from a plane on the inside bottom of the pocket to the top surface of the carrier.
5. Carrier camber shall be not than 1mm per 100mm through a length of 250mm.

Packing

Reel Dimension

