



承認書

SPECIFICATION FOR APPROVAL

客戶名稱及編號:

K4625

CUSTOMER:

產品名稱:

TOGGLE SWITCH

DESCRIPTION:

產品型號:

ST-1-103-A01-T000-RS

MODEL NO:

本司料號:

SM00750ZUR

OUR PART NO:

客戶料號:

C312271

CUSTOMER PART NO:

承認書編號:

YF-ENG-F-30116

SPECIFICATION NO:

日期:

2019-3-11

DATE:

WRITTEN 制定: 雷艳平

APPROVAL 審核:

承認書附頁: 圖紙,規格書

客戶承認欄

CUSTOMER APPROVAL SIGNATURE

MODEL NO.:

APPROVED NO.:

PART NO.:

DATE:



深圳市寶安區福永鎮第一工業區 24 棟
Tel:0755-33809280~3Fax:0755-33809285

自由公差	类别	公差
区分	0	<0.5
	0.50	<5
	5.0	<10
	10.0	<20
	20.0	<50
	未标注R角	R0.2
	未标注角度公差	±1°

REV	DESCRIPTION	DESIGNER	DATE

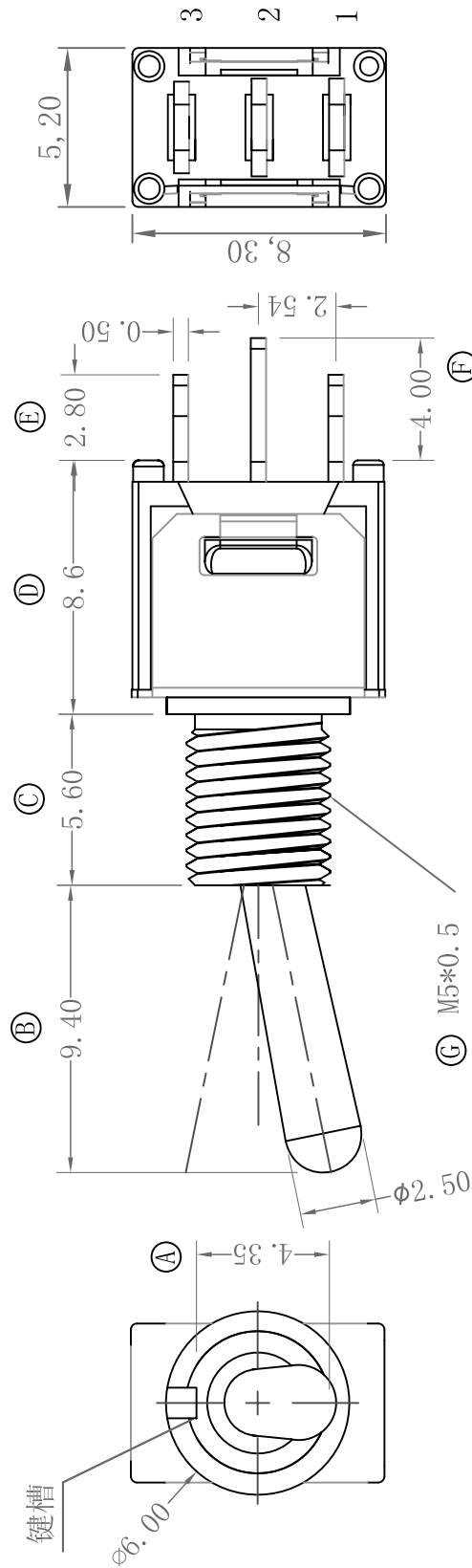
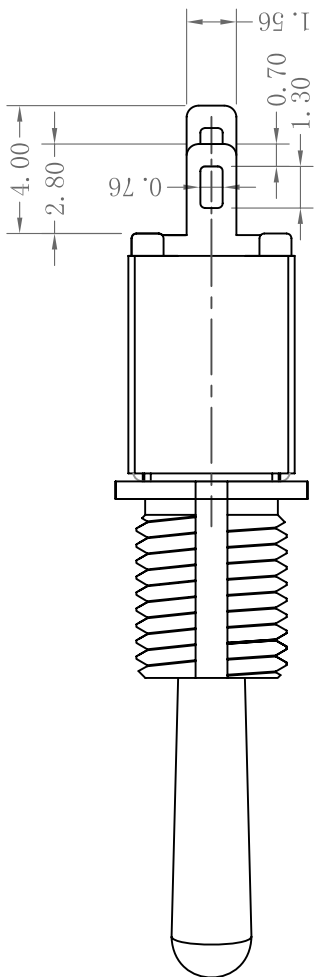

手柄位置及导通端子示意图

Model	POS. 1	POS. 2	POS. 3
NO.			
	ON	OFF	ON
103	ON	OFF	ON
SCHEMATIC		OPEN	
	1	2	3

标注: ①-⑥ 尺寸的重点检验尺寸

SCALE	1:1	UNIT: mm
CKD		DWN 黄泳何
APVD		DATE 2017-12-15
SPECIFICATION NO.		YF-ENG-F-30116
TITLE		Sub-Miniature Toggle Switch
PART NO.	ST-1-103-A01-T000-RS	
MATERIAL NO.	SM00750ZNR	
源丰电子公司 YuenFung Electronic Company		

NO	NAME	MATERIAL	QTY	FINISHING	NO	NAME	MATERIAL	QTY	FINISHING
1	手柄	黄铜	1	镀铬	7	动触点	H65	1	镀银
2	轴套	无铅铜	1	镀镍	8	端子	H65	3	镀银
3	铁盖	SUS-301	1	本色	9	底座	PPA	1	红色
4	弹簧	碳钢	1	黑色					
5	摆杆	SPCC	1	镀镍					
6	滑块	PA46	1	黑色					

YuenFung Electrnoic(shenzhen)Co.ltd

源丰电子(深圳)有限公司

SPECIFICATION 规格书		承认书编号	YF-ENG-F-30116
		版 本	A/0
		页 次	第1页 共3页
		发布日期	2018-9-11
WRITTEN 制定	邓颖恒	审 核	
		APP'D审批	
MODEL SERIES NAME 系列名称:		TOGGLE SWITCH	
MODEL NO 产品型号:		ST-1-103-A01-T000-RS	
1. RATING 额定值:		3A 250VAC 1.5A 125VAC	
2. FUNCTION 接触型式:		SPDT 3P	
3. CIRCUITRY TRAIT:		ON-OFF-ON	
4. ELECTRICAL CHARACTERISTICS 电气性能规格:			
ITEM 项目		TEST CONDITIONS 测试条件	PERFORMANCE 表现
4.1	CONTACT RESISTANCE 接触电阻	MEASURED AT SMALL CURRENT(100mA OR LESS)1000Hz 在微小电流(100mA)以下测试.	50m Ω MAX 50毫欧以下
4.2	INSULATION RESISTANCE 绝缘电阻	APPLY A VOL TAGE OF 500V DC FOR 1 MIN.TO FOLLOWING PORTIONS AFTER WHICH MEASUREMENT SHALL BE MADE: (1)BETWEEN BODY AND CONDUCTOR. (2)BETWEEN CONDUCTORS NOT TO BE CONTACT. 输入500V DC电压1分钟,按以下接触方法测试: (1)接触端子之间. (2)塑胶体与端子之间.	100M Ω MIN 100兆欧以上
4.3	DIELECTRIC STRENGTH 耐电压	AC1500V ims(50-60Hz)FOR 1 MIN : (1)BETWEEN TERMINALS. (2)BETWEEN INDIVIDUAL TERMINALS AND FRAME. 输入AC1500V (50-60Hz)电压1分钟,按以下接触方法测试: (1)接触端子之间.(2)塑胶体与端子之间.	NO DAMAGE TO PARTS ARCING,OR BREAKDOWN ETC. 没有绝缘破坏等异常.
5	PRACTICAL TEMPERATURE RANGE 使用温度范围	A-16℃~+85℃ 在-16℃~+85℃温度内使用	
6	STANDARD ATMOSPHEIC CONDITIONS 测试标准状态	UNLESS OTHERWISE SPECIFIED. THE STANDARD RANGE OF ATMOSPHERIC CONDITIONS FOR MAKING MEASUREMENTS AS FOLLOWS: (1)AMBIENT TEMPERATURE:5℃TO35℃. (2)RELATIVE HUMIDITY:45%TO85%. 在没有指定的情况下测试温度,湿度如下: (1)温度为5℃-35℃.(2)湿度为45%-85%.	
6.1	STORE THE PERIOD 储存期	TEMPERATUER: 0℃~30℃ 温度: 0℃~30℃ DEGREE OF HUMIDITY 湿度40%~70%	THREE MONTH 三个月

YuenFung Electrnoic(shenzhen)Co.ltd

源丰电子(深圳)有限公司

SPECIFICATION 规格书		承认书编号	YF-ENG-F-30116
		版 本	A/0
		页 次	第2页 共3页
		发布日期	2018-9-11
WRITTEN 制定	邓颖恒	审 核	
		APP'D审批	

7.MECHANICAL CHARACTERISTICS 机械性能规格:

ITEM项目		TEST CONDITIONS 测试条件	PERFORMANCE 表现
7.1	OPERATION FORCE 作动力		250±80gf
7.2	TERMINAL STRENGTH 端子强度	A STATIC LOAD OF 1Kgf SHALL BE APPLIED TO THE TIP OF THE TERMINAL FOR 15 SEC IN ANY DIRECTION 在任意一个方向的先端加上1Kgf力度测试,时间为15秒.	ELECTRICAL CHARACTERISTICS SHALL BE SATISFIED WITHOUT DAMAGE OR EXCESSIVE LOOSENESS OF TERMINALS 在排脚中没有裂开,松动等异常,满足于机械,电器性能.
7.3	LIFE TEST 寿命测试	1.ENDURANCE WITHOUT LOADING: THE TEST SHOULD BE TAKEN AT A SPEED OF 6-8 CYCLES FOR 1 MIN; 1.5 TIMES OF THE STANDARD FORCE 无负荷:每分钟6-8回速度测试压力不得超过标准力度1.5倍.进行测试 2.ENDURANCE WITH LOADING: THE TEST SHOULD BE TAKEN AT A SPEED OF 6-8 CYCLES FOR 1 MIN; OPERATE PRESSURE SHOULD BE UNDER THE 1.5 TIMES OF THE STANDARD FORCE 负荷:在负荷的条件下以每分钟6-8回的速度压力不得超过标准力度1.5倍.进行测试	(1). 20,000 CYCLES CONTACT AT WITHOUT LOADING. 在无负荷下20,000次接触 (2). 10,000 CYCLES MECHANICAL AND ELECTRICAL CHARACTERISTICS SHALL BE SATISFIED 10,000次满足于机械, 电器性能;

8.DURABILITY 耐久性:

ITEM项目		TEST CONDITIONS 测试条件	PERFORMANCE 表现
8.1	SOLDERABILITY TEST 可焊性试验	THE TOP OF THE TERMINALS SHALL BE DIPPED 2mm IN THE SOLDER BATH OF 230±10°C FOR 3±0.5 SECONDS. 端子顶部被浸入锡焊池中2mm深,浓度为230±10°C,时间为3±0.5秒.	THE AREA OF SOLDERING, SHOULD BE OVER 75%. 焊接面积要有75%以上.
8.2	RESISTANCE TO SOLDERING HEAT TEST 耐焊性试验	SOLDER BATH METHOD: SOLDER TEMPERATURE 260±5°C, IMMERSION TIME 3±0.5 SEC, IMMERSION DEPTH UP TO THE SURFACE OF THE BOARD, DIMENSIONS OF COMPONENT HOLES IN THE PRINTED WIRING BOARD SHALL BE IN ACCORDANCE WITH THOSE SPECIFIED IN THIS SPECIFICATION. 焊炉焊接的时候温度控制在260±5°C,过炉时间3±0.5秒. 手焊接的时候温度控制在360°C ± 5°C, 时间为3±0.5秒.	WITHOUT DEFORMATION OF CASE OR EXCESSIVE LOOSENESS OF TERMINALS ELECTRICAL CHARACTERISTICS SHALL BE SATISFIED. 本体无变形,能满足于机械,电器性能.

YuenFung Electrnoic(shenzhen)Co.ltd

源丰电子(深圳) 有限公司

SPECIFICATION 规格书		承认书编号	YF-ENG-F-30116
		版 本	A/0
		页 次	第3页 共3页
		发布日期	2018-9-11
WRITTEN 制定	邓颖恒	审 核	
		APP'D审批	
ITEM项目	TEST CONDITIONS 测试条件		PERFORMANCE 表现
8.3	HEAT TEST 耐热试验	<p>THE SWITCH SHALL BE STORED AT A TEMPERATURE OF $85\pm 2^{\circ}\text{C}$ FOR 96 HOURS. THEN THE SWITCH SHALL BE MAINTAINED AT STANDARD ATMOSPHERIC CONDITION FOR 1 HOUR AFTER WHICH MEASUREMENT SHALL BE MADE.</p> <p>放置在温度$85\pm 2^{\circ}\text{C}$中测试96小时后,再放置正常室温中1小时来测定.</p>	<p>THERE SHALL BE NO DEFORMATION OR CRACKS IN MOLDED PART 外观无异常,满足于机械,电器性能.</p>
8.4	COLD TEST 耐冷试验	<p>THE SWITCH SHALL BE STORED AT A TEMPERATURE OF $-20\pm 3^{\circ}\text{C}$ FOR 96 HOURS, THEN THE SWITCH SHALL BE MAINTAINED AT STANDARD ATMOSPHERIC CONDITION FOR 1 HOUR AFTER WHICH MEASUREMENT SHALL BE MADE.</p> <p>放置在温度$-20\pm 3^{\circ}\text{C}$中96小时后,再放置常温中1小时来进行测试.</p>	
8.5	HUMIDITY TEST 潮湿试验	<p>THE SWITCH SHALL BE STORED AT A TEMPERATURE OF $40\pm 2^{\circ}\text{C}$ AND A HUMIDITY OF 90% TO 95% FOR 96 HOURS. THEN THE SWITCH SHALL BE MAINTAINED AT STANDARD ATMOSPHERE CONDITION FOR 1 HOUR AFTER WHICH MEASUREMENT SHALL BE MADE.</p> <p>放置$40\pm 2^{\circ}\text{C}$试验的相对湿度为90%-95%环境中96小时后,再将样板放在正常环境1小时后进行测试.</p>	